

FED. SUP CLASS
5935

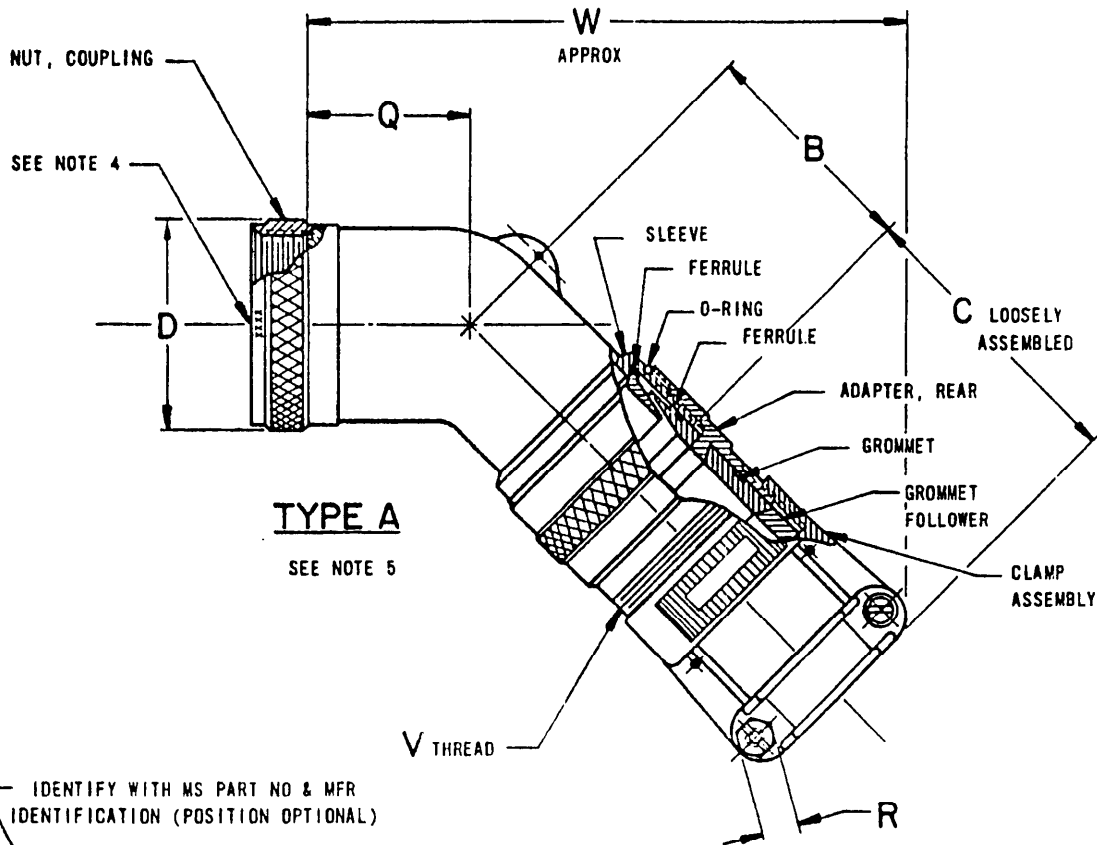

TYPE A
SEE NOTE 5

IDENTIFY WITH MS PART NO & MFR IDENTIFICATION (POSITION OPTIONAL)

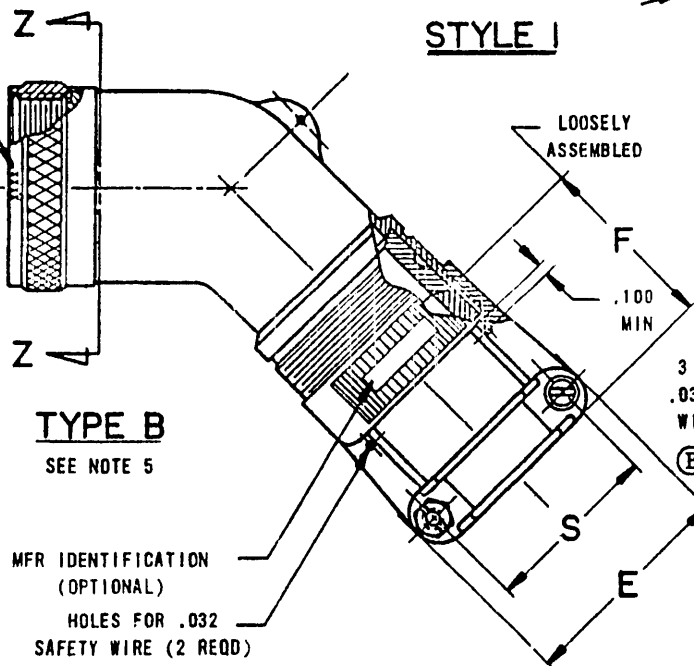

TYPE B
SEE NOTE 5

STYLE I

VIEW Z-Z

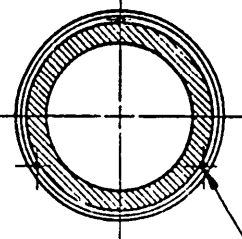

3 EQUALLY SPACED HOLES FOR .032 SAFETY WIRE. ADDITIONAL WIRE HOLES, MANUFACTURER'S OPTION

ⓑ INACTIVE FOR DESIGN AFTER 1 JULY 1982. DOCUMENT WILL BE CANCELLED 1 JULY 1984, USE MIL-C-85049/6, /7, /23.

ⓑ DENOTES CHANGES

This military standard is approved by the NAVAL AIR SYSTEMS COMMAND, NAVY-AS, Department of the NAVY and shall be used by that activity. All other military activities are required to employ this standard where suitable.

P.A. Navy - AS	INTERNATIONAL INTEREST	TITLE BACKSHELL, 45°, CABLE SEALING AND SHIELD TERMINATION, CONNECTOR, ELECTRIC	MILITARY STANDARD
Other Cust			MS3189(NAVY)
Procurement Specifications	SUPERSEDES:	MS3439	SHEET 1 OF 13

APPROVED 23 Jan 74 REVISED ⓐ 5 Nov 1975 ⓑ 10 May 1982

This military standard is approved by the **NAVAL AIR SYSTEMS COMMAND, NAVY-AS**, Department of the **NAVY** and shall be used by that activity. All other military activities are required to employ this standard where suitable.

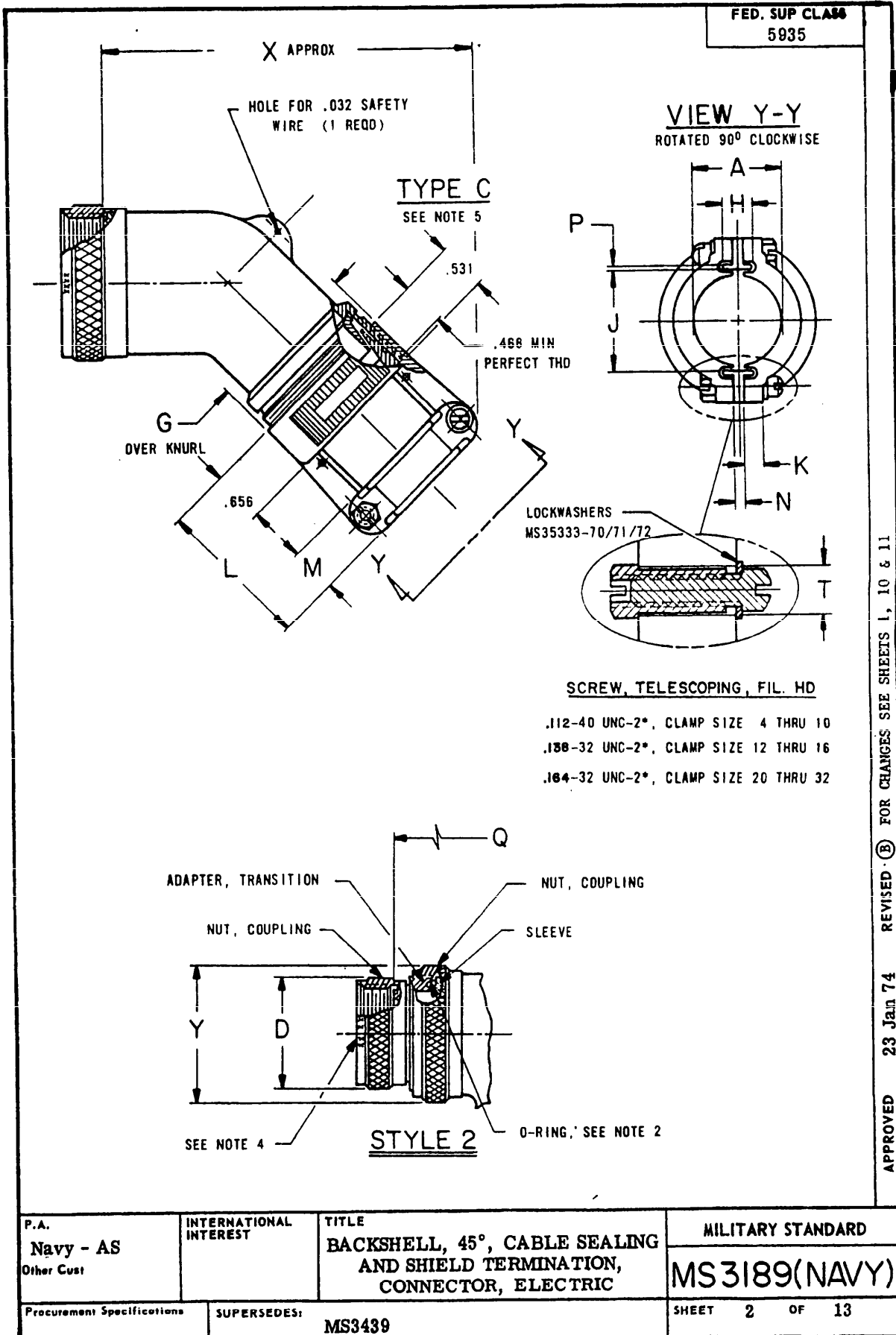

FED. SUP CLASS
5935

APPROVED 23 Jan 74 REVISED (B) FOR CHANGES SEE SHEETS I, 10 & 11

P.A. Navy - AS Other Cust	INTERNATIONAL INTEREST	TITLE BACKSHELL, 45°, CABLE SEALING AND SHIELD TERMINATION, CONNECTOR, ELECTRIC	MILITARY STANDARD
			MS3189(NAVY)
Procurement Specifications	SUPERSEDES: MS3439		SHEET 2 OF 13

FED. SUP CLASS
5935

DASH NO	FITS SHELL OF CONNECTOR				CLAMP SIZE	A		STYLE	B	C	D DIA	E	F	G DIA	H
	MIL-C-81703 SER 3	MIL-C-0026482 SER 2	MIL-C-005015 CRIMP	MIL-C-83723 SER 1/3		CABLE RANGE	±.062		REF	MAX	±.020	REF	MAX	±.010	
															MIN
1	3	X	X	X	4	.125	.250	1	1.790	1.544	.669	.937	1.027	.937	.218
2					6	.250	.437	2	1.910	1.544	.669	1.125	1.027	1.031	.281
3	X	8	8S	8	4	.125	.250	1	1.182	1.544	.617	.937	1.027	.937	.218
4		4	.125	.312	1	1.850	1.544	.734	.937	1.027	.937	.218			
5	X	10	OS, 10SL	10	6	.250	.375	1	1.245	1.544	.734	1.125	1.027	1.031	.281
6					4	.125	.312	1	1.910	1.544	.858	.937	1.027	.937	.218
7	7	12	12, 12S	12	6	.250	.437	1	1.910	1.544	.858	1.125	1.027	1.031	.281
8					10	.350	.500	1	1.910	1.844	.858	1.312	1.027	1.250	.312
9	12	14	14, 14S	14	6	.250	.437	1	2.000	1.544	.984	1.125	1.027	1.031	.281
10					10	.350	.575	1	1.655	1.844	.994	1.312	1.027	1.250	.312

This military standard is approved by the NAVAL AIR SYSTEMS COMMAND, NAVY-AS, Department of the NAVY and shall be used by that activity. All other military activities are required to employ this standard where suitable.

DASH NO	J DIA ±.010	K ±.010	L ±.020	M ±.010	N ±.010	P ±.010	Q ±.062	R +.000 -.007	S ±.010	T DIA ±.005	V THREAD CLASS 2A	W APPROX	X APPROX	Y DIA MAX
1	.322	.156	1.281	.312	.109	.062	.561	.250	.637	.166	.625-24 UNEF	3.37	3.00	-
2	.447	.175	1.281	.375	.125	.062	1.375	.250	.763	.166	.750-20 UNEF	4.33	3.97	.858
3	.322	.156	1.281	.312	.109	.062	.500	.250	.637	.166	.625-24 UNEF	2.88	2.52	-
4	.322	.156	1.281	.312	.109	.062	.561	.250	.637	.166	.625-24 UNEF	3.41	3.05	-
5	.447	.175	1.281	.375	.125	.062	.561	.250	.763	.166	.750-20 UNEF	3.05	2.69	-
6	.322	.156	1.281	.312	.109	.062	.625	.250	.637	.166	.625-24 UNEF	3.52	3.16	-
7	.447	.175	1.281	.375	.125	.062	.625	.250	.763	.166	.750-20 UNEF	3.58	3.22	-
8	.635	.218	1.281	.437	.125	.062	.625	.250	.964	.166	1.000-20 UNEF	3.86	3.29	-
9	.447	.175	1.281	.375	.125	.062	.688	.250	.763	.166	.750-20 UNEF	3.71	3.35	-
10	.635	.218	1.281	.437	.125	.062	.688	.250	.964	.166	1.000-20 UNEF	3.74	3.17	-

P.A. Navy - AS Other Cust	INTERNATIONAL INTEREST	TITLE BACKSHELL, 45°, CABLE SEALING AND SHIELD TERMINATION, CONNECTOR, ELECTRIC	MILITARY STANDARD MS3189(NAVY)
Procurement Specifications	SUPERSEDES: MS3439	SHEET 3 OF 13	

APPROVED 23 Jan 74 REVISED (B) FOR CHANGES SEE SHEETS 1, 10 & 11

FED. SUP CLASS
5935

DASH NO	FITS SHELL OF CONNECTOR				CLAMP SIZE	A		STYLE	B	C	D DIA	E	F	G DIA	H			
	MIL-C-81703 SER 3	MIL-U-0026482 SER 2	MIL-C-005015 CRIMP	MIL-C-83723 SER 1/3		CABLE RANGE	±.062		REF	MAX	±.020	REF	MAX	±.010				
															MIN	MAX		
11	19	16	16,16S	16	6	.250	.437	1	2.110	1.544	1.112	1.125	1.027	1.031	.281			
12					12	.500	.700	1	1.750	1.916	1.112	1.531	1.059	1.437	.375			
13	27	18	18	18	10	.350	.625	1	2.300	1.844	1.218	1.312	1.027	1.250	.312			
14					16	.625	.779	1	1.938	2.000	1.218	1.750	1.156	1.688	.375			
15	37	20	20	20	10	.350	.625	1	2.300	1.844	1.345	1.312	1.027	1.250	.312			
16					16	.625	.904	1	1.938	2.000	1.345	1.750	1.156	1.688	.375			
17	X	X	X	X	12	.500	.750	1	2.450	1.916	1.468	1.531	1.059	1.437	.375			
18					20	.875	1.029	1	2.093	2.230	1.468	2.093	1.375	2.000	.475			
19					24	24	24	12	.500	.750	1	2.450	1.916	1.593	1.531	1.059	1.437	.375
20								20	.875	1.144	1	2.093	2.230	1.593	2.093	1.375	2.000	.475

DASH NO	J DIA ±.010	K ±.010	L ±.020	M ±.010	N ±.010	P ±.010	Q ±.062	R +.000 - .007	S ±.010	T DIA ±.005	V THREAD CLASS 2A	W APPROX	X APPROX	Y DIA MAX
11	.447	.175	1.261	.375	.125	.062	.781	.250	.763	.166	.750-20 UNEF	3.88	3.52	-
12	.760	.250	1.312	.437	.156	.062	.781	.250	1.130	.192	1.187-18 UNEF	4.03	3.43	-
13	.635	.218	1.281	.437	.125	.062	.968	.250	.964	.166	1.000-20 UNEF	4.48	3.91	-
14	.947	.250	1.406	.531	.188	.062	.968	.250	1.375	.192	1.437-18 UNEF	4.49	3.90	-
15	.635	.218	1.281	.437	.125	.062	.968	.250	.964	.166	1.000-20 UNEF	4.48	3.91	-
16	.947	.250	1.406	.531	.188	.062	.968	.250	1.375	.192	1.437-18 UNEF	4.49	3.90	-
17	.760	.250	1.312	.437	.156	.062	1.063	.250	1.130	.192	1.187-18 UNEF	4.81	4.21	-
18	1.260	.312	1.593	.531	.188	.078	1.063	.312	1.703	.217	1.750-18 UNS	4.98	4.38	-
19	.760	.250	1.312	.437	.156	.062	1.063	.250	1.130	.192	1.187-18 UNEF	4.81	4.21	-
20	1.260	.312	1.593	.531	.188	.078	1.063	.312	1.703	.217	1.750-18 UNS	4.98	4.38	-

P.A. Navy - AS Other Cust	INTERNATIONAL INTEREST	TITLE BACKSHELL, 45°, CABLE SEALING AND SHIELD TERMINATION, CONNECTOR, ELECTRIC	MILITARY STANDARD MS3189(NAVY)
Procurement Specifications	SUPERSEDES: MS3439	SHEET 4 OF 13	

APPROVED 23 Jan 74 REVISED (B) FOR CHANGES SEE SHEETS 1, 10 & 11

This military standard is approved by the NAVAL AIR SYSTEMS COMMAND, NAVY-AS, Department of the NAVY and shall be used by that activity. All other military activities are required to employ this standard where suitable.

FED. SUP CLASS
5935

DASH NO	FITS SHELL OF CONNECTOR				CLAMP SIZE	A		STYLE	B ± .062	C REF	D DIA MAX ± .020	E REF	F DIA MAX ± .010	H	
	MIL-C-81703 SER 3	MIL-C-0026482 SER 2	MIL-C-005015 CRIMP	MIL-C-83723 SER 1/3		CABLE RANGE	MIN								MAX
21			28		16	.625	.937	1	2.500	2.000	1.969	1.750	1.156	1.688	.375
22					24	1.000	1.375	1	2.156	2.024	1.969	2.343	1.500	2.250	.500
23					16	.625	.937	1	2.600	2.000	2.219	1.750	1.156	1.688	.375
24			32		20	.875	1.250	1	2.600	2.230	2.219	2.093	1.375	2.000	.475
25					28	1.250	1.625	1	2.250	2.550	2.219	2.750	1.781	2.500	.625
26					16	.625	.937	1	2.690	2.000	2.469	1.750	1.156	1.688	.375
27			36		24	1.000	1.375	1	2.690	2.024	2.469	2.343	1.500	2.250	.500
28					32	1.437	1.840	1	2.344	2.600	2.469	3.000	1.830	2.750	.675
29					16	.625	.937	1	2.690	2.000	2.719	1.750	1.156	1.688	.375
30			40		24	1.000	1.375	1	2.690	2.024	2.719	2.343	1.500	2.250	.500

This military standard is approved by the NAVAL AIR SYSTEMS COMMAND, NAVY-AS, Department of the NAVY and shall be used by that activity. All other military activities are required to employ this standard where suitable.

DASH NO	J DIA ± .010	K ± .010	L ± .020	M ± .010	N ± .010	P ± .010	Q ± .062	R + .000 - .007	S ± .010	T DIA ± .005	V THREAD CLASS 2A	W APPROX	X APPROX	Y DIA MAX
21	.947	.250	1.406	.531	.188	.062	1.188	.250	1.375	.192	1.437-18 UNEF	5.11	4.52	-
22	1.385	.312	1.625	.531	.250	.093	1.188	.312	1.906	.217	2.000-18 UNS	5.09	4.72	-
23	.947	.250	1.406	.531	.188	.062	1.250	.250	1.375	.192	1.437-18 UNEF	5.24	4.65	-
24	1.260	.312	1.593	.531	.188	.078	1.250	.312	1.703	.217	1.750-18 UNS	5.52	4.92	-
25	1.635	.312	1.900	.812	.375	.093	1.250	.312	2.218	.217	2.250-16 UN	5.73	5.19	-
26	.947	.250	1.406	.531	.188	.062	1.281	.250	1.375	.192	1.437-18 UNEF	5.33	4.74	-
27	1.385	.312	1.625	.531	.250	.093	1.281	.312	1.906	.217	2.000-18 UNS	5.56	5.19	-
28	1.885	.312	1.900	.812	.375	.125	1.281	.312	2.500	.217	2.500-16 UN	5.95	5.41	-
29	.947	.250	1.406	.531	.188	.062	2.031	.250	1.375	.192	1.437-18 UNEF	6.08	5.48	-
30	1.385	.312	1.625	.531	.250	.093	2.031	.312	1.906	.217	2.000-18 UNS	6.31	5.94	-

P.A. Navy - AS Other Cust	INTERNATIONAL INTEREST	TITLE BACKSHELL, 45°, CABLE SEALING AND SHIELD TERMINATION, CONNECTOR, ELECTRIC	MILITARY STANDARD MS3189(NAVY)
Procurement Specifications	SUPERSEDES:	MS3439	SHEET 5 OF 13

APPROVED 23 Jan 74 REVISED (B) FOR CHANGES SEE SHEETS 1, 10 & 11

This military standard is approved by the NAVAL AIR SYSTEMS COMMAND, NAVY-AS, Department of the NAVY and shall be used by that activity. All other military activities are required to employ this standard where suitable.

FED. SUP CLASS 5935															
DASH NO	FITS SHELL OF CONNECTOR				CLAMP SIZE	A		STYLE	B	C	D DIA	E	F	G DIA	H
	MIL-C-81703 SER 3	MIL-C-0026482 SER 2	MIL-C-005015 CRIMP	MIL-C-83723 SER 1/3		CABLE RANGE			±.062	REF	MAX	±.020	REF	MAX	±.010
	MIN	MAX													
31			40		32	1.437	1.875	1	2.344	2.600	2.719	3.000	1.830	2.750	.675
32					16	.625	.937	1	2.690	2.000	2.969	1.750	1.156	1.688	.375
33			44		24	1.000	1.375	1	2.690	2.024	2.969	2.343	1.500	2.250	.500
34					32	1.437	1.875	1	2.344	2.600	2.969	3.000	1.830	2.750	.675
35					16	.625	.937	1	2.690	2.000	3.219	1.750	1.156	1.688	.375
36			48		24	1.000	1.375	1	2.690	2.024	3.219	2.343	1.500	2.250	.500
37					32	1.437	1.875	1	2.344	2.600	3.219	3.000	1.830	2.750	.675
38					12	.500	.750	1	2.450	1.916	1.653	1.531	1.059	1.437	.375
39	61				20	.875	1.184	1	2.093	2.230	1.653	2.093	1.375	2.000	.475
40	19	16	16,16S	16	10	.350	.625	1	2.110	1.844	1.112	1.312	1.027	1.250	.312

DASH NO	J DIA ±.010	K ±.010	L ±.020	M ±.010	N ±.010	P ±.010	Q ±.062	R ±.000 -.007	S ±.010	T DIA ±.005	V ITHREAD CLASS 2A	W APPROX	X APPROX	Y DIA MAX
31	1.885	.312	1.900	.812	.375	.125	2.031	.312	2.500	.217	2.500-16 UN	6.70	6.16	-
32	.947	.250	1.406	.531	.188	.062	2.031	.250	1.375	.192	1.437-18 UNEF	6.08	5.49	-
33	1.385	.312	1.625	.531	.250	.093	2.031	.312	1.906	.217	2.000-18 UNS	6.31	5.94	-
34	1.885	.312	1.900	.812	.375	.125	2.031	.312	2.500	.217	2.500-16 UN	6.70	6.16	-
35	.947	.250	1.406	.531	.188	.062	2.031	.250	1.375	.192	1.437-18 UNEF	6.08	5.49	-
36	1.385	.312	1.625	.531	.250	.093	2.031	.312	1.906	.217	2.000-18 UNS	6.31	5.94	-
37	1.885	.312	1.900	.812	.375	.125	2.031	.312	2.500	.217	2.500-16 UN	6.70	6.16	-
38	.760	.250	1.312	.437	.156	.062	1.063	.250	1.130	.192	1.187-18 UNEF	4.81	4.21	-
39	1.260	.312	1.593	.531	.188	.078	1.063	.312	1.703	.217	1.750-18 UNS	4.98	4.38	-
40	.635	.218	1.281	.437	.125	.062	.781	.250	.964	.166	1.000-20 UNEF	4.16	3.59	-

P.A. Navy - AS	INTERNATIONAL INTEREST	TITLE BACKSHELL, 45°, CABLE SEALING AND SHIELD TERMINATION, CONNECTOR, ELECTRIC	MILITARY STANDARD MS3189(NAVY)
Other Cust			
Procurement Specifications	SUPERSEDES: MS3439		SHEET 6 OF 13

APPROVED 23 Jan 74 REVISED (B) FOR CHANGES SEE SHEETS 1, 10 & 11

FED. SUP CLASS 5935																		
DASH NO	FITS SHELL OF CONNECTOR				CLAMP SIZE	A		STYLE	±.062	B	C	D DIA MAX	E ±.020	F REF	G DIA MAX	H ±.010		
	MIL-C-81703 SER 3	MIL-C-0026482 SER 2	MIL-C-005015 CRIMP	MIL-C-83723 SER 1/3		MIN	MAX											
41	27	18	18	18	4	.125	.312	1	2.300	1.544	1.218	.937	1.027	.937	.218			
42					6	.250	.437	1	2.300	1.544	1.218	1.125	1.027	1.031	.281			
43	37	20	20	20	6	.250	.437	1	2.300	1.544	1.345	1.125	1.027	1.031	.281			
44	X	22	22	22	4	.125	.312	1	2.450	1.544	1.468	.937	1.027	.937	.218			
45					6	.250	.437	1	2.450	1.544	1.468	1.125	1.027	1.031	.281			
46					24	24	24	10	.350	.625	1	2.450	1.844	1.593	1.312	1.027	1.250	.312
47					X	36	X	12	.500	.750	1	2.690	1.916	2.469	1.531	1.059	1.437	.375
48	X	40	X	12	.500	.750	1	2.690	1.916	2.719	1.531	1.059	1.437	.375				
49	X	10	10S, 10SL	10	6	.250	.437	2	1.910	1.544	.734	1.125	1.027	1.031	.281			
50	12	14	14, 14S	14	12	.500	.750	2	2.300	1.916	.984	1.531	1.059	1.437	.375			

DASH NO	J DIA ±.010	K ±.010	L ±.020	M ±.010	N ±.010	P ±.010	Q ±.062	R ±.000 - .007	S ±.010	T DIA ±.005	V THREAD CLASS 2A	W APPROX	X APPROX	Y DIA MAX
41	.322	.156	1.281	.312	.109	.062	.968	.250	.637	.166	.625-24 UNEF	4.13	3.80	-
42	.447	.175	1.281	.375	.125	.062	.968	.250	.763	.166	.750-20 UNEF	4.20	3.84	-
43	.447	.175	1.281	.375	.125	.062	.968	.250	.763	.166	.750-20 UNEF	4.20	3.84	-
44	.322	.156	1.281	.312	.109	.062	1.063	.250	.637	.166	.625-24 UNEF	4.34	3.98	-
45	.447	.175	1.281	.375	.125	.062	1.063	.250	.763	.166	.750-20 UNEF	4.40	4.04	-
46	.635	.218	1.281	.437	.125	.062	1.063	.250	.964	.166	1.000-20 UNEF	4.68	4.11	-
47	.760	.250	1.312	.437	.156	.062	1.281	.250	1.130	.192	1.187-18 UNEF	5.20	4.60	-
48	.760	.250	1.312	.437	.156	.062	2.031	.250	1.130	.192	1.187-18 UNEF	5.95	5.35	-
49	.447	.175	1.281	.375	.125	.062	1.375	.250	.763	.166	.750-20 UNEF	4.33	3.97	.858
50	.760	.250	1.312	.437	.156	.062	1.717	.250	1.130	.192	1.187-18 UNEF	5.36	4.76	1.218

P.A. Navy - AS Other Cust	INTERNATIONAL INTEREST	TITLE BACKSHELL, 45°, CABLE SEALING AND SHIELD TERMINATION, CONNECTOR, ELECTRIC	MILITARY STANDARD MS3189(NAVY)
Procurement Specifications	SUPERSEDES: MS3439	SHEET 7 OF 13	

This military standard is approved by the NAVAL AIR SYSTEMS COMMAND, NAVY-AS, Department of the NAVY and shall be used by that activity. All other military activities are required to employ this standard where suitable.

APPROVED 23 Jan 74 REVISED (B) FOR CHANGES SEE SHEETS 1, 10 & 11

FED. SUP CLASS
5935

DASH NO	FITS SHELL OF CONNECTOR				CLAMP SIZE	A		STYLE	B	C	D DIA	E	F	G DIA	H
	MIL-C-81703 SER 3	MIL-C-0026482 SER 2	MIL-C-005015 CRIMP	MIL-C-83723 SER 1/3		CABLE RANGE	±.062		±.062	REF	MAX	±.020	REF	MAX	±.010
									MIN	MAX					
51	19	16	16,16S	16	16	.625	.937	2	2.450	2.000	1.112	1.750	1.156	1.688	.375
52	27	18	18	18	12	.500	.750	1	2.300	1.916	1.218	1.531	1.059	1.437	.375
53	61	X	X	X	16	.625	.937	1	2.450	2.000	1.653	1.750	1.156	1.688	.375
54	37	20	20	20	12	.500	.750	1	2.300	1.916	1.345	1.531	1.059	1.437	.375
55					20	.875	1.250	2	2.500	2.230	1.345	2.093	1.375	2.000	.475
56	X	22	22	22	10	.350	.625	1	2.450	1.844	1.468	1.312	1.027	1.250	.312
57					16	.625	.937	1	2.450	2.000	1.468	1.750	1.156	1.688	.375
58					20	.875	1.250	2	2.500	2.230	1.468	2.093	1.375	2.000	.475
59	X	24	24	24	16	.625	.937	1	2.450	2.000	2.093	1.750	1.156	1.688	.375
60		X	X	X	12	.500	.750	1	2.500	1.916	1.969	1.531	1.059	1.437	.375

DASH NO	J DIA ±.010	K ±.010	L ±.020	M ±.010	N ±.010	P ±.010	Q ±.062	R +.000 -.007	S ±.010	T DIA ±.005	V THREAD CLASS 2A	W APPROX	X APPROX	Y DIA MAX
51	.947	.250	1.406	.531	.188	.062	1.812	.250	1.375	.192	1.437-18 UNEF	5.70	5.11	1.468
52	.760	.250	1.312	.437	.156	.062	.968	.250	1.130	.192	1.187-18 UNEF	4.61	4.01	-
53	.947	.250	1.406	.531	.188	.062	1.063	.250	1.375	.192	1.437-18 UNEF	4.95	4.36	-
54	.760	.250	1.312	.437	.156	.062	.968	.250	1.130	.192	1.187-18 UNEF	4.61	4.01	-
55	1.260	.312	1.593	.531	.188	.078	1.936	.312	1.703	.217	1.750-18 UNS	6.14	5.54	1.969
56	.635	.218	1.281	.437	.125	.062	1.063	.250	.964	.166	1.000-20 UNEF	4.68	4.11	-
57	.947	.250	1.406	.531	.188	.062	1.063	.250	1.375	.192	1.437-18 UNEF	4.95	4.36	-
58	1.260	.312	1.593	.531	.188	.078	1.936	.312	1.703	.217	1.750-18 UNS	6.14	5.54	1.969
59	.947	.250	1.406	.531	.188	.062	1.063	.250	1.375	.192	1.437-18 UNEF	4.95	4.36	-
60	.760	.250	1.312	.437	.156	.062	1.188	.250	1.130	.192	1.187-18 UNEF	4.97	4.37	-

APPROVED 23 Jan 74 REVISED (B) FOR CHANGES SEE SHEETS 1, 10 & 11

This military standard is approved by the NAVAL AIR SYSTEMS COMMAND, NAVY-AS, Department of the NAVY and shall be used by that activity. All other military activities are required to employ this standard where suitable.

P.A. Navy - AS	INTERNATIONAL INTEREST	TITLE BACKSHELL, 45°, CABLE SEALING AND SHIELD TERMINATION, CONNECTOR, ELECTRIC	MILITARY STANDARD MS3189(NAVY)
Other Cust			
Procurement Specifications	SUPERSEDES: MS3439	SHEET 8 OF 13	

FED. SUP CLASS
5935

DASH NO	FITS SHELL OF CONNECTOR				CLAMP SIZE	A		STYLE	B ±.062	C REF	D DIA MAX	E ±.020	F REF	G DIA MAX	H ±.010
	MIL-C-81703 SER 3	MIL-C-0026482 SER 2	MIL-C-005015 CRIMP	MIL-C-83723 SER 1/3		CABLE RANGE									
						MIN	MAX								
61			28		20	.875	1.250	1	2.500	2.230	1.969	2.093	1.375	2.000	.475
62			32		24	1.000	1.375	1	2.600	2.024	2.219	2.343	1.500	2.250	.500
63			36		20	.875	1.250	1	2.690	2.230	2.469	2.093	1.375	2.000	.475
64					28	1.250	1.625	1	2.690	2.550	2.469	2.750	1.781	2.500	.625
65			40		20	.875	1.250	1	2.690	2.230	2.719	2.093	1.375	2.000	.475
66					28	1.250	1.625	1	2.690	2.550	2.719	2.750	1.781	2.500	.625
67			44		20	.875	1.250	1	2.690	2.230	2.969	2.093	1.375	2.000	.475
68					28	1.250	1.625	1	2.690	2.550	2.969	2.750	1.781	2.500	.625
69			48		20	.875	1.250	1	2.690	2.230	3.219	2.093	1.375	2.000	.475
70					28	1.250	1.625	1	2.690	2.550	3.219	2.750	1.781	2.500	.625

DASH NO	J DIA ±.010	K ±.010	L ±.020	M ±.010	N ±.010	P ±.010	Q ±.062	R +.000 -.007	S ±.010	T DIA ±.005	V THREAD CLASS 2A	W APPROX	X APPROX	Y DIA MAX
61	1.260	.312	1.593	.531	.188	.078	1.188	.312	1.703	.217	1.750-18 UNS	5.39	4.79	-
62	1.385	.312	1.625	.531	.250	.093	1.250	.312	1.906	.217	2.000-18 UNS	5.47	5.10	-
63	1.260	.312	1.593	.531	.188	.078	1.281	.312	1.703	.217	1.750-18 UNS	5.62	5.02	-
64	1.635	.312	1.900	.812	.375	.093	1.281	.312	2.218	.217	2.250-16 UN	6.08	5.54	-
65	1.260	.312	1.593	.531	.188	.078	2.031	.312	1.703	.217	1.750-18 UNS	6.37	5.77	-
66	1.635	.312	1.900	.812	.375	.093	2.031	.312	2.218	.217	2.250-16 UN	6.83	6.29	-
67	1.260	.312	1.593	.531	.188	.078	2.031	.312	1.703	.217	1.750-18 UNS	6.37	5.77	-
68	1.635	.312	1.900	.812	.375	.093	2.031	.312	2.218	.217	2.250-16 UN	6.83	6.29	-
69	1.260	.312	1.593	.531	.188	.078	2.031	.312	1.703	.217	1.750-18 UNS	6.37	5.77	-
70	1.635	.312	1.900	.812	.375	.093	2.031	.312	2.218	.217	2.250-16 UN	6.83	6.29	-

This military standard is approved by the NAVAL AIR SYSTEMS COMMAND, NAVY-AS, Department of the NAVY and shall be used by that activity. All other military activities are required to employ this standard where suitable.

P.A. Navy - AS Other Cust	INTERNATIONAL INTEREST	TITLE BACKSHELL, 45°, CABLE SEALING AND SHIELD TERMINATION, CONNECTOR, ELECTRIC	MILITARY STANDARD MS3189 (NAVY)
Procurement Specifications	SUPERSEDES: MS3439	SHEET 9 OF 13	

APPROVED 23 Jan 74 REVISED (B) FOR CHANGES SEE SHEETS 1, 10 & 11

FED. SUP CLASS
5935

DASH NO	FITS SHELL OF CONNECTOR				CLAMP SIZE	A		STYLE	B ±.062	C REF	D DIA MAX	E ±.020	F REF	G DIA MAX	H ±.010
	MIL-C-81703 SER 3	MIL-C-0026482 SER 2	MIL-C-005015 CRIMP	MIL-C-83723 SER 1/3		CABLE RANGE									
						MIN	MAX								
71	7	12	12,12S	12	10	.350	.625	2	2.110	1.844	.858	1.312	1.027	1.250	.312
72	27	18	18	18	16	.625	.937	2	2.450	2.000	1.218	1.750	1.156	1.688	.375
73	X	24	24	24	20	.875	1.250	2	2.500	2.230	1.468	2.093	1.375	2.000	.475
74	12	14	14,14S	14	4	.125	.312	1	2.000	1.544	.984	.937	1.027	.937	.218
75	19	16	16,16S	16	4	.125	.312	1	2.110	1.544	1.112	.937	1.027	.937	.218
76	X	X	28	X	24	1.000	1.375	2	2.800	2.024	1.969	2.343	1.500	2.250	.500
77	X	X	32	X	28	1.250	1.675	2	2.770	2.550	2.219	2.750	1.781	2.500	.625
78	X	X	36	X	32	1.437	1.875	2	2.415	2.600	2.469	3.000	1.830	2.750	.675

(B)
(B)
(B)

DASH NO	J DIA ±.010	K ±.010	L ±.020	M ±.010	N ±.010	P ±.010	Q ±.062	R +.000 -.007	S ±.010	T DIA ±.005	V THREAD CLASS 2A	W APPROX	X APPROX	Y DIA MAX
	71	.635	.218	1.281	.437	.125	.062	1.528	.250	.964	.166	1.000-20 UNEF	4.90	4.33
72	.947	.250	1.406	.531	.188	.062	1.812	.250	1.375	.192	1.437-18 UNEF	5.69	5.10	1.468
73	1.260	.312	1.593	.531	.188	.078	1.936	.312	1.703	.217	1.750-18 UNS	6.13	5.53	1.969
74	.322	.156	1.281	.312	.109	.062	.688	.250	.637	.166	.625-24 UNEF	3.64	3.28	-
75	.322	.156	1.281	.312	.109	.062	.761	.250	.637	.166	.625-24 UNEF	3.81	3.45	-
76	1.385	.312	1.625	.531	.188	.093	2.566	.312	1.906	.217	2.000-18 UNF	X	X	X
77	1.635	.312	1.900	.821	.375	.093	2.566	.312	2.218	.217	2.250-16 UN	X	X	X
78	1.895	.312	1.900	.821	.375	.125	3.316	.312	2.500	.217	2.500-16 UN	X	X	X

(B)
(B)
(B)

APPROVED 23 Jan 74 REVISED (B) FOR CHANGES SEE SHEETS 1, 10 & 11

This military standard is approved by the NAVAL AIR SYSTEMS COMMAND, NAVY - AS, Department of the NAVY and shall be used by that activity. All other military activities are required to employ this standard where suitable.

P.A. Navy - AS Other Cust	INTERNATIONAL INTEREST	TITLE BACKSHELL, 45°, CABLE SEALING AND SHIELD TERMINATION, CONNECTOR, ELECTRIC	MILITARY STANDARD MS3189(NAVY)
Procurement Specifications	SUPERSEDES: MS3439	SHEET 10 OF 13	

FED. SUP CLASS
5935

REQUIREMENTS:

1. UNLESS OTHERWISE SPECIFIED, TOLERANCES SHALL BE: .XX = ± 0.01 ; .XXX = ± 0.005 .
ANGULAR: $X^{\circ} = \pm 1^{\circ} 00'$; $X^{\circ} XX' = \pm 0^{\circ} 30'$.
2. MATERIAL: BACKSHELL COMPONENTS: ALUMINUM ALLOY
GROMMETS AND O-RING: SILICONE, PER ZZ-M-765, CLASS 3A OR 3B
CLAMP ASSEMBLY SCREWS: 300 SERIES STAINLESS STEEL
3. FINISH:
 - A - CADMIUM PLATE, PER QQ-P-416, TYPE II, CLASS 3, OVER NICKEL; COLOR OLIVE DRAB (ELECTRICALLY CONDUCTIVE)
 - C - CADMIUM PLATE, PER QQ-P-416, TYPE II, CLASS 3; COLOR - OLIVE DRAB (ELECTRICALLY CONDUCTIVE)
4. THIS REAR ACCESSORY SHALL CONFORM TO MS3155 (DESIGN STANDARD). MS3155 TAKES PRECEDENCE OVER THIS STANDARD.
5. APPLICATIONS:
 - A. TYPE A BACKSHELLS ARE FOR SHIELD TERMINATION AND ENVIRONMENTAL APPLICATIONS. ARMOR SHIELD TERMINATION AND ENVIRONMENTAL APPLICATIONS MAY BE ACHIEVED BY REVERSING THE FERRULES AND GROMMETS.
 - B. TYPE B BACKSHELLS ARE FOR ENVIRONMENTAL APPLICATIONS ONLY AND ARE TYPE A LESS THE REAR ADAPTER AND FERRULES AND WITH THE GROMMET REPLACING THE FERRULES.
 - C. TYPE C BACKSHELLS ARE FOR SHIELD TERMINATION APPLICATIONS ONLY AND ARE TYPE A LESS THE REAR ADAPTER AND GROMMET.
 - D. STYLE 2 APPLIES WHEN THE CABLE DIAMETER EXCEEDS E DIAMETER OF MS3155.
 - E. SEE MS3437 FOR ASSEMBLY SEQUENCE.
6. QUALIFICATION:

ONE SAMPLE IN EACH SHELL SIZE RANGE (SEE TABLE 1) FOR WHICH QUALIFICATION IS DESIRED SHALL BE TESTED. EACH SAMPLE SHALL BE ASSEMBLED TO AN APPROPRIATE CONNECTOR OR DUMMY CONNECTOR WHICH DUPLICATES THE CONNECTOR INTERFACING FEATURES. THE BACKSHELL SHALL BE ASSEMBLED WITH A 6 FOOT MINIMUM LENGTH CABLE APPROACHING THE DESIGNATED MINIMUM DIAMETER. CABLE SHALL BE IN ACCORDANCE WITH MIL-C-915. TESTING SHALL BE AS FOLLOWS AND SHALL BE PERFORMED IN THE SEQUENCE LISTED.

 - A. EXAMINATION OF PRODUCT
 - (B)** B. MAGNETIC PERMEABILITY -
THE RELATIVE MAGNETIC PERMEABILITY SHALL BE LESS THAN 2.0 FOR CLASSES A, C AND N WHEN CHECKED WITH AN INDICATOR CONFORMING TO MIL-I-17214. WIRED ASSEMBLIES SHALL NOT BE CARRYING CURRENT.
 - C. SHELL CONDUCTIVITY -
ASSEMBLIES SHALL BE ELECTRICALLY CONDUCTIVE FROM THE CONNECTOR BODY TO THE TERMINATED CABLE SHIELD AT A POINT LOCATED 1.0 INCH \pm .25 INCH TO REAR OF ADAPTER. THE OVERALL D.C. RESISTANCE SHALL NOT EXCEED 0.05 OHMS WHEN MEASURED BY THE VOLTMETER-AMMETER METHOD. THE APPLIED POTENTIAL SHALL BE 1.5 VOLTS MAXIMUM. A RESISTANCE SHALL BE INSERTED IN THE CIRCUIT TO LIMIT THE CURRENT TO 1.00 \pm .010 AMPERES.
 - D. VIBRATION -
A COUNTERPART RECEPTACLE CONNECTOR SHALL BE MOUNTED ON A SUITABLE FIXTURE, WHICH IN TURN SHALL BE ATTACHED TO THE VIBRATION TABLE. A SUITABLE SENSOR SHALL MONITOR THE VIBRATION OF THE RECEPTACLE AT A POINT ON OR NEAR THE RECEPTACLE. THE PLUG CONNECTOR AND BACKSHELL ASSEMBLY SHALL BE ENGAGED WITH THE RECEPTACLE BY NORMAL LOCKING MEANS. NO SAFETY WIRE SHALL BE USED. THE CABLES SHALL BE CLAMPED TO NON-VIBRATING POINTS AT LEAST 8 INCHES FROM THE REAR OF THE ASSEMBLY. THE CLAMPING LENGTH SHALL BE CHOSEN TO AVOID RESONANCE OF THE CABLE. THE ASSEMBLY SHALL THEN BE SUBJECTED TO THE VIBRATION REQUIREMENTS OF MIL-STD-167-1 (SHIPS) PARAGRAPH 5.1.3.3.3 AND METHOD 204, CONDITION B, OF MIL-STD-202. THERE SHALL BE NO LOOSENING OF PARTS OR EVIDENCE OF DAMAGE DUE TO VIBRATION.

This military standard is approved by the NAVAL AIR SYSTEMS COMMAND, NAVY-AS, Department of the NAVY and shall be used by that activity. All other military activities are required to employ this standard where suitable.

APPROVED 23 Jan 74 REVISED (B) FOR CHANGES SEE SHEETS 1, 10 & 11

P.A. Navy - AS	INTERNATIONAL INTEREST	TITLE BACKSHELL, 45°, CABLE SEALING AND SHIELD TERMINATION, CONNECTOR, ELECTRIC	MILITARY STANDARD
Other Cust			MS3189(NAVY)
Procurement Specifications	SUPERSEDES:	MS3439	SHEET 11 OF 13

DD FORM 672 (LIMITED COORDINATION)

MAY 73

PREVIOUS EDITIONS OF THIS FORM ARE OBSOLETE

DATE

FED. SUP CLASS
5935

REQUIREMENTS (CONTINUED)

6. QUALIFICATION (CONTINUED)

E. SHOCK -

A COUNTERPART RECEPTACLE CONNECTOR SHALL BE MOUNTED ON FIXTURES IN ACCORDANCE WITH MIL-S-901, LIGHTWEIGHT. THE PLUG CONNECTOR AND BACKSHELL ASSEMBLY SHALL BE ENGAGED WITH THE RECEPTACLE BY NORMAL LOCKING MEANS. NO SAFETY WIRE SHALL BE USED. CABLES SHALL BE SUPPORTED ON A STATIONARY FRAME A MINIMUM DISTANCE OF 36 INCHES FROM THE ASSEMBLY. THE ASSEMBLY SHALL THEN BE SUBJECTED TO THE REQUIREMENTS OF MIL-S-901, GRADE A. THERE SHALL BE NO LOOSENING OF PARTS OR EVIDENCE OF DAMAGE DUE TO SHOCK.

F. MOISTURE RESISTANCE -

THE CONNECTOR AND BACKSHELL ASSEMBLY SHALL BE MOUNTED HORIZONTALLY WITH THE CABLE DESCENDING INTO THE BACKSHELL WITH NO DRIP LOOPS OR SPLICES WITHIN THE CHAMBER. THE CABLE SHALL LEAVE THE CHAMBER THROUGH VAPOR-TIGHT SEALS. THE FACE OF THE CONNECTOR SHALL BE PROTECTED FROM THE TEST ENVIRONMENT. THE TEST SHALL BE IN ACCORDANCE WITH METHOD 106 OF MIL-STD-202 (EXCEPT VIBRATION). THERE SHALL BE NO EVIDENCE OF MOISTURE ENTRANCE INTO THE BACKSHELL.

G. WATER PRESSURE -

THE CONNECTOR AND BACKSHELL ASSEMBLY SHALL BE ASSEMBLED WITH A CABLE OR TEST PLUG INSTALLED TO SIMULATE JACKETED CABLE. THE FACE OF THE CONNECTOR SHALL BE PROTECTED FROM THE TEST ENVIRONMENT. THE ASSEMBLY SHALL BE IMMERSUED IN TAP WATER TO A DEPTH OF 6 FEET FOR A PERIOD OF 48 HOURS. ASSEMBLY SHALL SHOW NO EVIDENCE OF WATER ENTRANCE.

H. CORROSION -

SALT SPRAY TEST IN ACCORDANCE WITH METHOD 1001 OF MIL-STD-1344. THERE SHALL BE NO EXPOSURE OF BASIS METAL DUE TO CORROSION WHICH WILL AFFECT PERFORMANCE.

J. CABLE PULL-OUT -

A SOLID POLYCHLOROPRENE TEST PLUG OF SUITABLE LENGTH WITH O.D. CONFORMING TO TABLE I AND A SHORE A DUROMETER OF 75-85, SHALL BE INSTALLED IN THE ADAPTER IN LIEU OF CABLE. TO FACILITATE THE APPLICATION OF LOADS, THE POLYCHLOROPRENE TEST PLUG MAY BE PROVIDED WITH A METAL CORE. THE APPLICABLE TENSILE LOAD SPECIFIED IN TABLE I SHALL BE APPLIED TO THE TEST PLUG IN THE DIRECTION TENDING TO DISPLACE IT TOWARD THE REAR OF THE ADAPTER. THE LOAD SHALL BE APPLIED FOR A PERIOD OF ONE HOUR AND THE AMOUNT OF SLIPPAGE SHALL BE MEASURED. CABLES SHALL NOT PULL OUT WHEN SPECIFIED LOADS ARE APPLIED, NOR SHALL THE SLIPPAGE EXCEED 1/8 INCH.

K. POST EXAMINATION OF PRODUCT.

7. QUALITY ASSURANCE PROVISION:

A. EXAMINATION OF PRODUCT.

8. APPLICATION FOR QUALIFICATION:

- A. THE ACTIVITY RESPONSIBLE FOR THE QUALIFIED PRODUCTS LIST (QPL) FOR MS3188 IS THE NAVAL AIR SYSTEMS COMMAND. THE NAVAL WEAPONS SUPPORT CENTER, CRANE, INDIANA, HAS BEEN DESIGNATED BY THE NAVAL AIR SYSTEMS COMMAND AS AGENT FOR THE ESTABLISHMENT OF THE QPL. REQUESTS FOR INFORMATION PERTAINING TO AND APPLICATIONS FOR QUALIFICATION SHOULD BE ADDRESSED TO:

COMMANDING OFFICER
NAVAL WEAPONS SUPPORT CENTER
CRANE, INDIANA 47522
ATTN: CODE 3074

APPROVED 23 Jan 74 REVISED (B) FOR CHANGES SEE SHEETS 1, 10 & 11

This military standard is approved by the NAVAL AIR SYSTEMS COMMAND, NAVY-AS, Department of the NAVY and shall be used by that activity. All other military activities are required to employ this standard where suitable.

P.A. Navy - AS Other Cust	INTERNATIONAL INTEREST	TITLE BACKSHELL, 45°, CABLE SEALING AND SHIELD TERMINATION, CONNECTOR, ELECTRIC	MILITARY STANDARD MS3189 (NAVY)
Procurement Specifications	SUPERSEDES: MS3439		SHEET 12 OF 13

FED. SUP CLASS
5935

TABLE I

DASH NUMBER	CABLE SEALING RANGE		TEST PLUG DIAMETER (INCHES)		PULL-OUT LOAD (POUNDS)	SHELL SIZE RANGE
	MINIMUM DIA (INCHES)	MAXIMUM DIA (INCHES)				
			MIN	MAX		
03	.125	.250	.109	.125	25	1
05	.250	.375	.234	.250		
10	.350	.575	.334	.350		
12	.500	.700	.484	.500	50	1
14	.625	.779	.609	.625		
18	.875	1.029	.859	.875		
22	1.000	1.375	.984	1.000	75	2
25	1.250	1.625	1.234	1.250		
28	1.437	1.875	1.421	1.437		
31	1.437	1.875	1.421	1.437	100	3
34	1.437	1.875	1.421	1.437		
37	1.437	1.875	1.421	1.437		

PART NUMBER DEVELOPMENT
EXAMPLE: MS3189 C 06 C

BASIC NO. _____

TYPE (A, B OR C) _____

DASH NO. _____

FINISH (SEE NOTE 3) _____

This military standard is approved by the NAVAL AIR SYSTEMS COMMAND, NAVY-AS, Department of the NAVY and shall be used by that activity. All other military activities are required to employ this standard where suitable.

P.A. Navy - AS	INTERNATIONAL INTEREST	TITLE BACKSHELL, 45°, CABLE SEALING AND SHIELD TERMINATION, CONNECTOR, ELECTRIC	MILITARY STANDARD
Other Cust			MS3189(NAVY)
Procurement Specifications	SUPERSEDES:	MS3439	SHEET 13 OF 13

APPROVED 23 Jan 74 REVISED (B) FOR CHANGES SEE SHEETS 1, 10 & 11