

FED. SUP CLASS  
4820

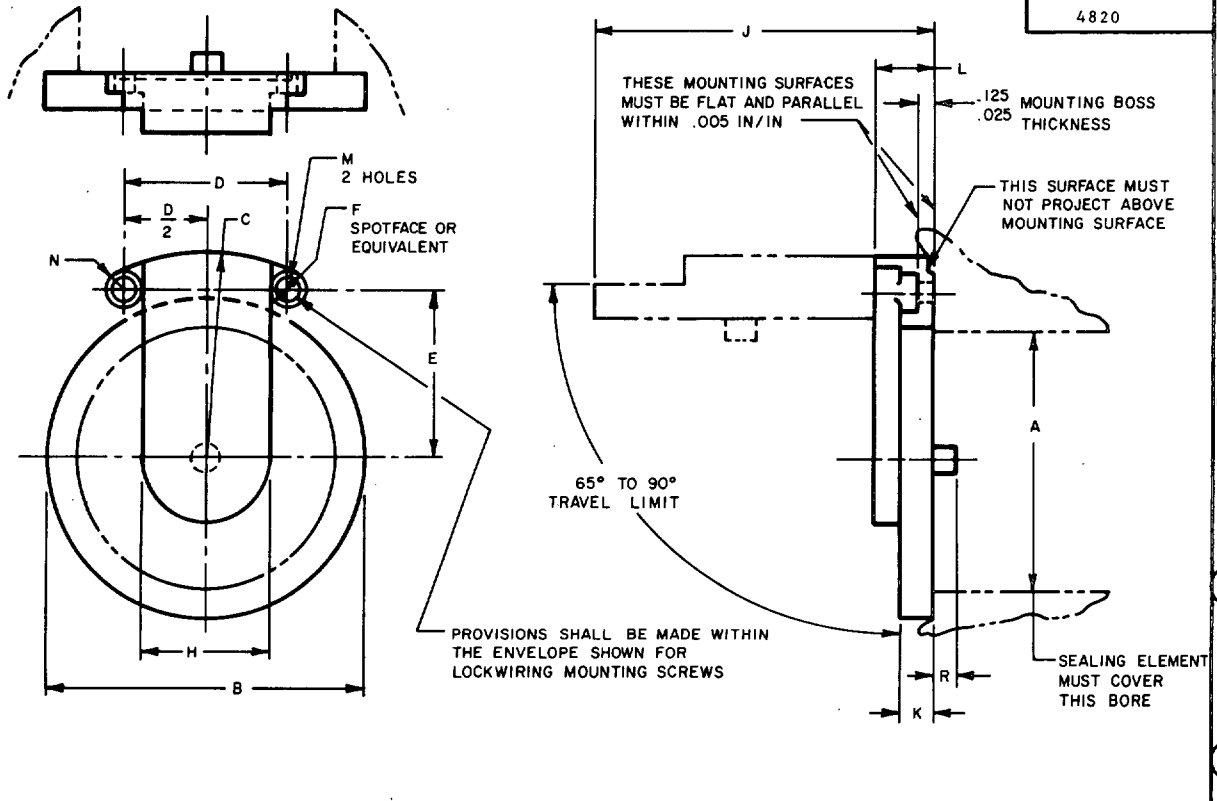

User activities:

Review activities:

This military standard is approved for use by all Departments and Agencies of the Department of Defense. Selection for all new engineering and design applications and for repetitive use shall be made from this document when applicable.

DASH NO.	A DIA.	B MAX. DIA.	C MAX. RAD.	D	D/2	E	F	H (REP)	J MAX	K MAX	L MAX	M DIA	N MIN RAD	R MAX	RATED FLOW GPM	TUBING SIZE IN.
-12A	.561	.933	.767	.860	.4300	.440		.550	1.086	.182	.282				15	.75
-16	.792	1.183	.916	1.110	.5550	.525		.806	1.337	.198	.335				30	1.
-20	1.024	1.527	1.097	1.248	.6240	.710		.940	1.704	.226	.373			.156	50	1.25
-24	1.248	1.777	1.200	1.240	.6200	.845	.304	.930	1.968	.236	.382	.1495	.152		70	1.50
-28	1.483	2.090	1.350			1.025		.930	2.324	.249	.395				100	1.75
-32	1.719	2.277	1.451	1.382	.6910	1.100		1.078	2.511	.267	.470				130	2.
-40	2.203	2.809	1.809	1.406	.7030	1.500		1.102	3.160	.287	.500			.219	215	2.50
-48	2.703	3.309	2.046	1.656	.8280	1.703		1.352	3.735	.307	.531				320	3.3
-56	3.213	3.996	2.395	2.093	1.0470	1.984		1.789	4.215	.327	.563				450	3.50
-64	3.711	4.496	2.667	2.313	1.1560	2.234		2.009	4.715	.347	.594				600	4.

(F)

Material: See procurement specifications  
Color identification per MIL-F-8615  
The valves, when mounted on MS33535 pad and discharging into an open tank, shall achieve the following performance:

- Opening and closing pressure per MIL-V-7899
- Pressure drop at rated flow shall be less than 45 inches water.
- Leakage: -32 and smaller - 0.5 cc per minute (max)  
larger sizes - 1.0 cc per minute (max)

Assembly date mark per MIL-STD-1523  
Dimensions in inches. Tolerances: .XXX +.005  
.XXXX ±.0025

(F)

FOR DESIGN FEATURE PURPOSES, THIS STANDARD TAKES PRECEDENCE OVER PROCUREMENT DOCUMENTS REFERENCED HEREIN. REFERENCED DOCUMENTS SHALL BE OF THE ISSUE IN EFFECT ON DATE OF INVITATIONS FOR BID.

(F)

DENOTES CHANGE

P.A. AIR FORCE - 82	TITLE	MILITARY STANDARD
Other Cust	DISK, VALVE	MS29521
ARMY - AV NAVY - AS AIR FORCE - 99		
PROCUREMENT SPECIFICATION	SUPERSEDES:	SHEET   OF
MIL-V-7899		

APPROVED 31 DEC 52 REVISED A 17 APR 53 B 4 SEP 62 C 12 JUN 74 D 12 JAN 76 E 13 MAY 77 F 17 MAY 84