

INCH-POUND

MS28921C
 19 April 2007
 SUPERSEDING
 MS28921B
 6 April 2001

DETAIL SPECIFICATION SHEET

HOSE ASSEMBLY, RUBBER, HYDRAULIC 3,000 PSI,
 STRAIGHT TO ELBOW 90°, FLARED TUBE

This specification is approved for use by all Departments and
 Agencies of the Department of Defense.

The requirements for acquiring the product described herein shall consist of this specification sheet and
 MIL-DTL-8790.

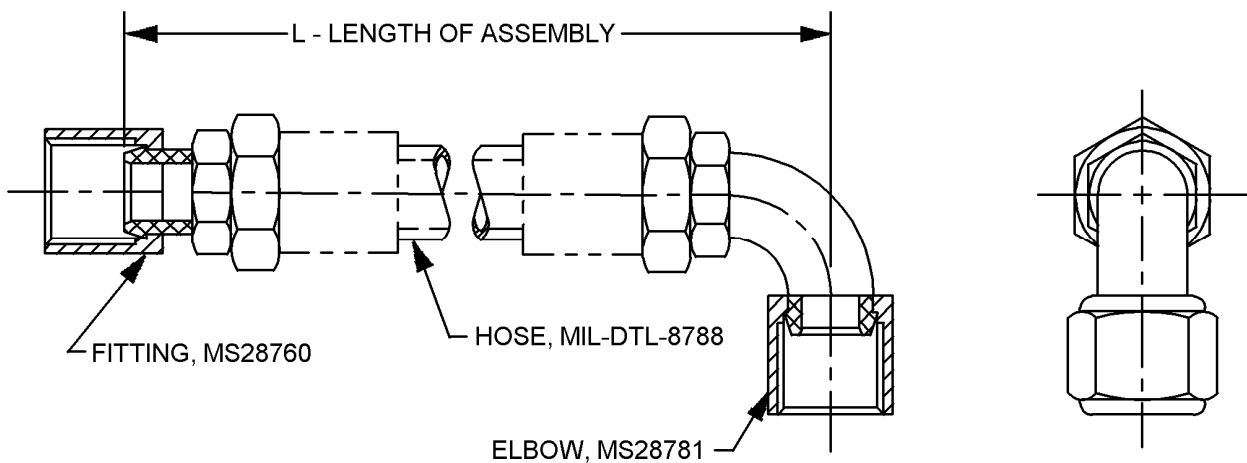

Dash size number	Tubing OD ref. inch (mm)	Hose ID ref. inch (mm)	End fittings PIN (see note 5)
-4	.25 (6.35)	.22 (5.59)	MS28760-4 and MS28781-4
-5	.31 (7.87)	.28 (7.11)	MS28760-5 and MS28781-5
-6	.38 (9.65)	.34 (8.64)	MS28760-6 and MS28781-6
-8	.50 (12.70)	.44 (11.18)	MS28760-8 and MS28781-8
-10	.63 (16.00)	.56 (14.22)	MS28760-10 and MS28781-10
-12	.75 (19.05)	.69 (17.53)	MS28760-12 and MS28781-12
-16	1.00 (25.40)	.88 (22.35)	MS28760-16 and MS28781-16

FIGURE 1. Hose assembly, flared tube dimensions and configuration.

MS28921C

NOTES:

1. Dimensions are in inches.
2. Metric equivalents are for information only.
3. Hose assembly lengths (L) shall be as specified with the following tolerances:
 - a. Under 18 inches (0.46 m) long ($\pm .13$ inch (3.3 mm)).
 - b. Over 18 to 36 inches (0.46 to 0.91 m) long ($\pm .25$ inch (6.4 mm)).
 - c. Over 36 to 50 inches long (0.91 to 1.27 m) ($\pm .50$ inch (12.7 mm)).
 - d. Over 50 inches long (Tolerance $\pm 1\%$).
4. Dash size number refers to the nominal outside diameter of the passageway in sixteenths (1/16) of an inch. A dash 8 (-8) has an outside diameter of one-half inch (8/16).
5. Part or Identifying Number (PIN).

FIGURE 1. Hose assembly, flared tube dimensions and configuration - Continued.

REQUIREMENTS:

Hose assemblies shall be as specified on figure 1.

The hose assembly identification shall be marked in accordance with MIL-DTL-8790.

PIN example:

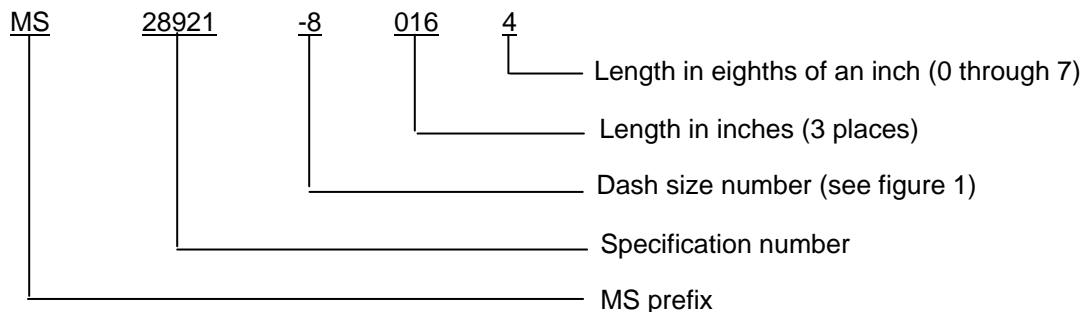

Example of a PIN: MS28921H0164, MS28921 hose assembly, .500 inch (1/2 inch) passageway diameter, 16.5 inches long.

Changes from previous issue. Marginal notations are not used in this revision to identify changes with respect to the previous issue, due to the extent of the changes.

Referenced documents. In addition to MIL-DTL-8790, this document references the following:

MS28760
MS28781
MIL-DTL-8788

MS28921C

CONCLUDING MATERIAL

Custodians:

Army - AT
Navy - AS
Air Force - 99
DLA - CC

Preparing activity:
DLA - CC

(Project 4720-2005-024)

Review activities:

Army - AV, MI
Navy - SA
Air Force - 71

NOTE: The activities listed above were interested in this document as of the date of this document. Since organizations and responsibilities can change, you should verify the currency of the information above using the ASSIST Online database at <http://assist.daps.dla.mil>.