

FED. SUP. CLASS.  
5310

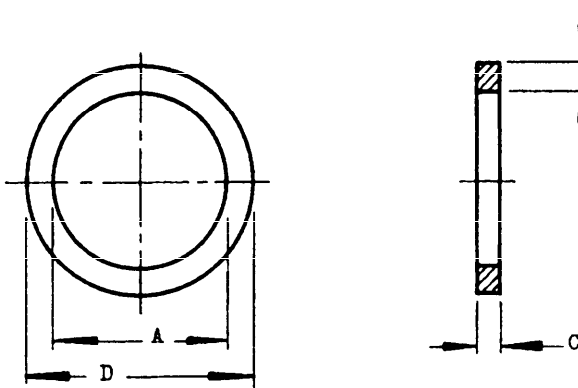

Review activities:  
Army - MI, AR  
DLA - IS

User activities:  
ARMY-ME

DASH NO.	TUBING OD	A + .0075 DIA	B + .0075 DIA	(a) C + .010	D DIA REF
2	1/8	.2340	.1089	.094	.452
3	3/16	.2960			.514
4	1/4	.3430			.577
5	5/16	.4060	.1169	.094	.640
6	3/8	.4680			.702
8	1/2	.6400	.1249	.125	.890
10	5/8	.7500	.1309		1.012
12	3/4	.9220	.1709		1.264
16	1	1.1720		1.514	
20	1-1/4	1.4840		1.826	
24	1-1/2	1.7340		2.076	
28	1-3/4	2.1090		2.451	
32	2	2.3590	2.701		

(C)

(a) THICKNESS C SHALL NOT VARY MORE THAN .010 BETWEEN ANY TWO POINTS ON A RING.

MATERIAL: SEE PROCUREMENT SPECIFICATION.

EDGES SHALL BE CUT CLEAN AND SQUARE TO WITHIN 5°.

DIMENSIONS IN INCHES.

FOR INSTALLATION DETAILS, SEE DRAWING MS21344.

FOR ACCEPTABLE PRODUCTS, SEE QPL-5521.

NOTES:

1. REFERENCED DOCUMENTS SHALL BE OF THE ISSUE IN EFFECT ON DATE OF INVITATIONS FOR BIDS, OR REQUEST FOR PROPOSAL, EXCEPT THAT REFERENCED ADOPTED INDUSTRY DOCUMENTS SHALL GIVE THE DATE OF THE ISSUE ADOPTED.
2. FOR DESIGN FEATURE PURPOSES, THIS STANDARD TAKES PRECEDENCE OVER PROCUREMENT DOCUMENTS REFERENCED HEREIN.

This military standard is mandatory for use by all departments and Agencies of the Department of Defense. Selection for all new engineering and design applications and for repetitive use shall be made from this document when applicable.

P. A. Air Force 82  
Other Cust Air Force-99  
Navy-AS  
Army-AV  
Procurement Specification  
MIL-W-5521

**MILITARY STANDARD**  
**WASHER, FLAT, AIRCRAFT**  
**HYDRAULIC BACKUP**

SUPERSEDES: AN6291

**MS28777**

SHEET 1 OF 1

APPROVED 3 May 57 REVISED (A) 30 Sep 1969 (B) 16 MARCH 83 (C) 16 May 1984