

INCH-POUND

MS28105D  
23 January 2006  
Superseding  
MS28105C  
17 November 1972

DETAIL SPECIFICATION SHEET  
COVER GLASS, AIRCRAFT INSTRUMENT DIAL

This specification sheet is approved for use by all Departments and Agencies of the Department of Defense.

The requirements for acquiring the product described herein shall consist of this specification sheet and MIL-G-81704.

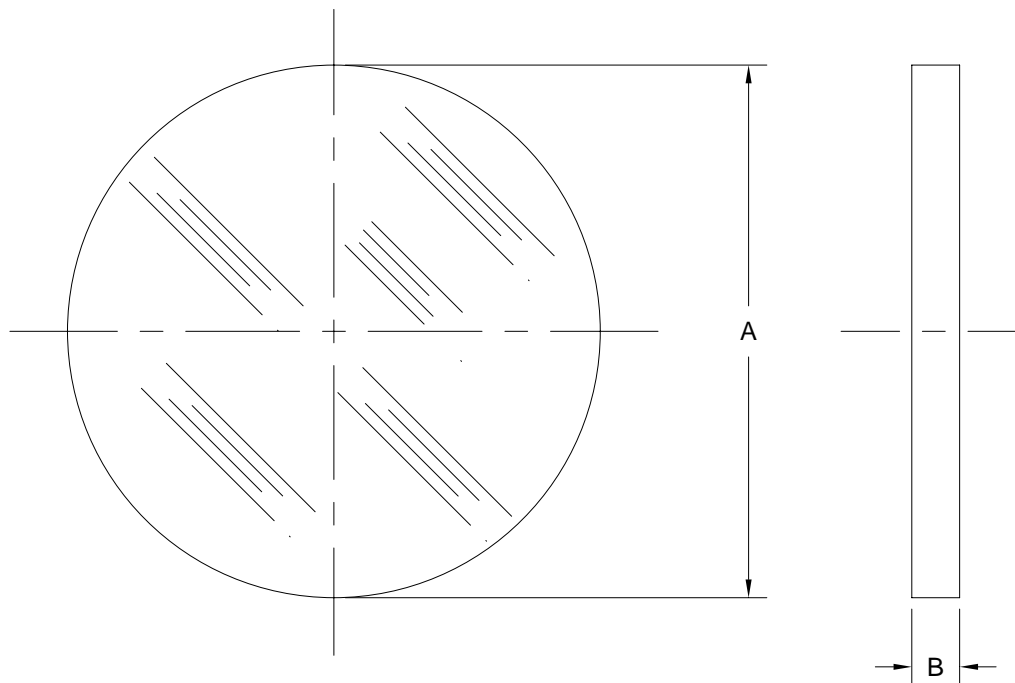

FIGURE 1. Cover Glass

## MS28105D

Table I. Dash numbers and dimensions.

DASH NO.	$\varnothing$ A	B
	+ .000 -.015	+ .016 -.005
-1	1.025	.062
-2		.125
-3	1.487	.062
-4		.125
-5	1.924	.062
-6		.125
-7	1.995	.062
-8		.125
-9	2.105	.062
-10	2.120	.125
-11		
-12	2.495	.062
-13	2.870	.125
-14		.062
-15	2.995	.125
-16		
-17	3.118	
-18	3.495	
-19	3.750	
-20	4.245	
-21	4.620	.062
-22	2.250	

## NOTES:

1. Dimensions in inches.
2. For design feature purposes, this standard takes precedence over documents referenced herein.
3. Changes from previous issue. Marginal notations are not used in this revision to identify changes with respect to the previous issue due to the extent of the changes.

Custodians:  
 Army - GL  
 Navy - AS  
 Air Force - 11

Preparing activity:  
 DLA - IS  
 (Project 5355-2005-002)

Reviewer activities:  
 Air Force - 84

NOTE: The activities listed above were interested in this document as of the date of this document. Since organizations and responsibilities can change, you should verify the currency of the information above using the ASSIST Online database at <http://assist.daps.dla.mil>.