

FED. SUP CLASS
6610

APPROVED 9 NOV 51 REVISED (A) 8 FEB 56 (B) 12 SEPT. 56 (C) 3 APR 58 (D) 1 DEC 55 (E) 15 OCT 68 (F) 18 NOV 69 (G) 31 JULY 73 (H) 5 APR 88

DIAL AND POINTER SHOWN FOR REFERENCE ONLY
FOR DETAILS-SEE PROCUREMENT SPECIFICATION

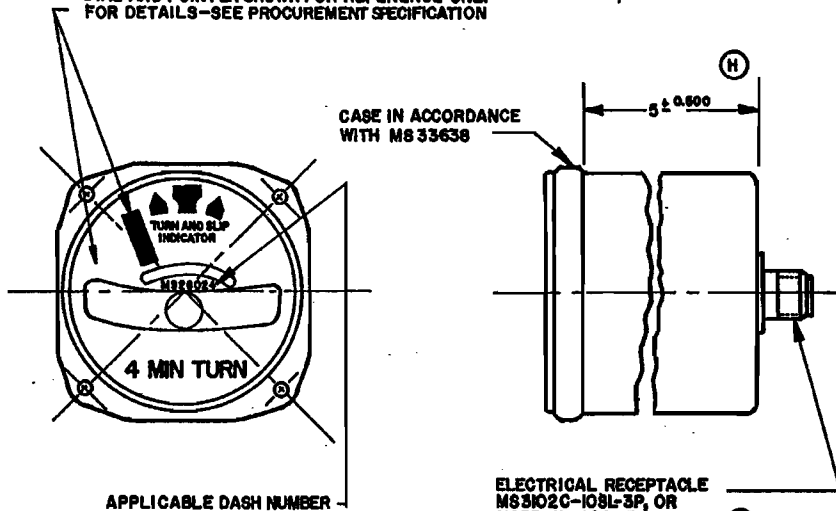

MS PART NO.	BALL COLOR	COLOR OF DIAL MARKING
(a) MS28024-1	DARK	
MS28024-2	WHITE	LUSTERLESS WHITE
MS28024-2A	WHITE	FLUORESCENT
MS28024-3	DARK	FLUORESCENT
MS28024-3A	DARK	LUSTERLESS WHITE

(a) PART NUMBER MS28024-1 INACTIVE FOR DESIGN AFTER 8 FEBRUARY 1966

FOR DEFINITION AND APPLICATION OF DRAWING STATUS NOTES SEE MIL-STD-962.

THE MANUFACTURER SHALL FURNISH SUFFICIENT MOUNTING SREWS NUMBER 6-32UNC-2A ROUND HEAD, BRASS, MACHINE, HAVING DURABLE, DULL BLACK, OXIDIZED OR BLACK NICKEL FINISH. LENGTH SHALL BE SUFFICIENT FOR MOUNTING IN PANEL .375 INCHES THICK.

DIMENSIONS IN INCHES.

CERTAIN PROVISIONS (VOLTAGE AND CASE DIMENSIONS) OF THIS STANDARD ARE THE SUBJECT OF INTERNATIONAL STANDARDIZATION AGREEMENT ASCC 10/6 AND STANAG 3322. WHEN REVISIONS OR CANCELLATION OF THIS STANDARD IS PROPOSED, WHICH WILL AFFECT OR VIOLATE THE INTERNATIONAL AGREEMENT CONCERNED, THE PREPARING ACTIVITY WILL TAKE APPROPRIATE RECONCILIATION ACTION THROUGH INTERNATIONAL STANDARDIZATION CHANNELS, INCLUDING DEPARTMENTAL STANDARDIZATION OFFICES, IF REQUIRED.

FOR DESIGN FEATURE PURPOSES, THIS STANDARD TAKES PRECEDENCE OVER DOCUMENTS REFERENCED HEREIN.

REFERENCE DOCUMENTS SHALL BE OF THE ISSUE IN EFFECT ON DATE OF INVITATIONS FOR BID.

DISTRIBUTION STATEMENT A. Approved for public release; distribution is unlimited.

AMSC N/A

This military standard is approved for use by all Departments and Agencies of the Department of Defense. Selection for all new engineering and design applications for replacement use shall be made from this document when applicable.

USER ACTIVITIES

REVISOR ACTIVITIES

P. A. USAF-71	INTERNATIONAL INTEREST	TITLE	MILITARY STANDARD
Other Cust		INDICATORS, TURN AND SLIP, 4-MINUTE TURN, 2 3/4 INCH DIAL	MS 28024
(H) NAVY-AS ARMY-AV AIRFORCE-99			SHEET 1 OF 1
PROCUREMENT SPECIFICATION MIL-L-7627	SUPERSEDES:		

DD FORM 672-1 (COORDINATED) 1 MAY 71

6610-0183