

THE REQUIREMENTS FOR ACCOUNTING THE PRODUCT(S) DESCRIBED HEREIN SHALL CONSIST OF THIS SPECIFICATION SHEET AND THE ISSUE OF THE FOLLOWING SPECIFICATION LISTED IN THAT ISSUE OF THE ADDRESS SPECIFIED IN THE SOLICITATION: ML-F-1088.

Form Approved
OMB No. 0704-0188

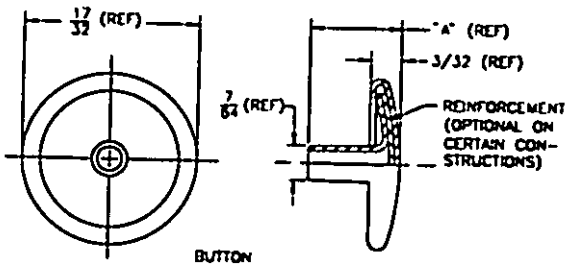

BUTTON

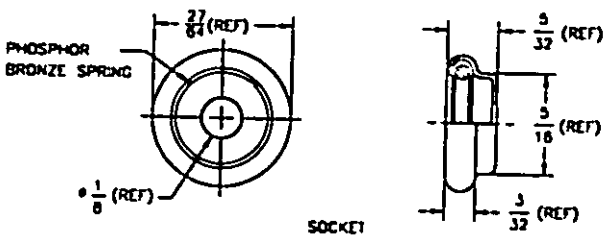

SOCKET

	SIZE	DIM. A (REF)	MS PART NO. (SEE NOTE 5.)		
			BLACK	NICKEL PLATE	BRIGHT CHROME
BUTTON	1	7/32	MS 27981 -1B	MS 27981 -1N	
BUTTON	2	9/32	MS 27981 -2B	MS 27981 -2N	
SOCKET			MS 27981 -3B	MS 27981 -3N	MS 27981 -3C

NOTE: BUTTON, SIZE 1 OR 2, AS APPLICABLE, AND SOCKET CONSTITUTE FEMALE HALF OF STYLE 2A FASTENER.

(C) ENTIRE SPECIFICATION REVISED

INCH-POUND

PREPARING ACTIVITY: DLA-IS CUSTODIANS: ARMY- NAVY- AS AIR FORCE- B2 DLA- REVIEW: AR, AT, AV, ER, MC, ME, MS, SM PROJECT NUMBER: 5325-0330	MILITARY SPECIFICATION SHEET TITLE FASTENERS, SNAP, STYLE 2A (SMALL WIRE SPRING CLAMP TYPE)	SPECIFICATION SHEET NUMBER MS27981 13 JUN 95 REV C SUPERSEDING MS27981 B 5 MAY 71 (SEE NOTE 4.) AMSC- N/A FSC 5325
---	--	---

DISTRIBUTION STATEMENT A. Approved for public release; distribution is unlimited. Page 1 of 3

THIS SPECIFICATION IS APPROVED FOR USE BY ALL DEPARTMENTS AND AGENCIES OF THE DEPARTMENT OF DEFENSE.

THE REQUIREMENTS FOR ACQUIRING THE PRODUCT(S) DESCRIBED HEREIN SHALL CONSIST OF THIS SPECIFICATION SHEET AND THE ISSUE OF THE FOLLOWING SPECIFICATION LISTED IN THAT ISSUE OF THE DODDS SPECIFIED IN THE SOLICITATION: MIL-F-10884

THIS SPECIFICATION IS APPROVED FOR USE BY ALL DEPARTMENTS AND AGENCIES OF THE DEPARTMENT OF DEFENSE.

Form Approved
OMB No. 0704-0188

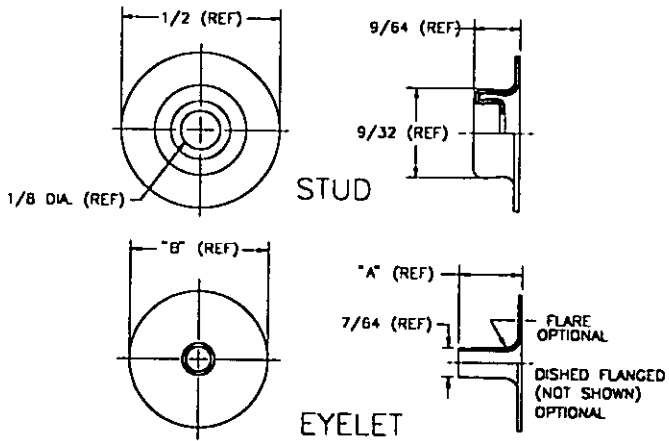

	SIZE	DIM. A (REF)	DIM. B (REF)	MS PART NO. (SEE NOTE 5.)			
				BRIGHT BRASS	BLACK	NICKEL PLATE	BRIGHT CHROME
STUD					MS 27981 -4B	MS 27981 -4N	MS 27981 -4C
EYELET	1	3/16	1/2		MS 27981 -5B	MS 27981 -5N	
EYELET	2	1/4		MS 27981 -6	MS 27981 -6B	MS 27981 -6N	
EYELET	3	21/64	3/8		MS 27981 -7B	MS 27981 -7N	MS 27981 -7C
EYELET	4	7/16				MS 27981 -8N	

NOTE: STUD AND EYELET, SIZE 1, 2, 3, OR 4, AS APPLICABLE, CONSTITUTE THE MALE HALF OF STYLE 2A FASTENER.

PREPARING ACTIVITY: DLA-15 CUSTODIANS: ARMY- NAVY- AS AIR FORCE- 82 DLA- REVIEW: AR, AT, AV, ER, MC, ME, MS, SM PROJECT NUMBER: 5325-0330 DISTRIBUTION STATEMENT	MILITARY SPECIFICATION SHEET TITLE FASTENERS, SNAP, STYLE 2A (SMALL WIRE SPRING CLAMP TYPE)	SPECIFICATION SHEET NUMBER MS27981 13 JUN 95 REV C SUPERSADING MS27981 B 5 MAY 71 (SEE NOTE 4.) AMSC- N/A FSC 5325
A. Approved for public release; distribution is unlimited.		Page 2 of 3

THE REQUIREMENTS FOR ACQUIRING THE PRODUCT(S) DESCRIBED HEREIN SHALL CONSIST OF THIS SPECIFICATION SHEET AND THE ISSUE OF THE FOLLOWING SPECIFICATION LISTED IN THAT ISSUE OF THE CROSS SPECIFIED IN THE SOLICITATION: MIL-F-10884

THIS SPECIFICATION IS APPROVED FOR USE BY ALL DEPARTMENTS AND AGENCIES OF THE DEPARTMENT OF DEFENSE.

Form Approved
OMB No. 0704-0188

REQUIREMENTS:

1. **MATERIAL:** ALL COMPONENTS ARE COMMERCIAL BRASS 7030.
2. **FINISH:**
 - a. BRIGHT BRASS.
 - b. BLACK.
 - c. NICKEL PLATE.
 - d. BRIGHT CHROME PLATE.
3. COMPONENT PARTS OF THE SAME FASTENER SHALL BE PRODUCED BY THE SAME MANUFACTURER.
4. **PART NUMBER:** THE PART NUMBER SHALL CONSIST OF THE BASIC MS NUMBER PLUS THE DASH NUMBER

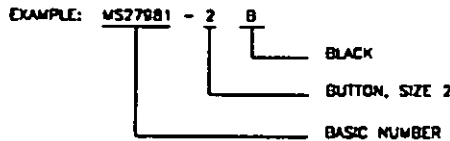

NOTES:

1. DIMENSIONS ARE IN INCHES. DIMENSIONS FOR INFORMATION PURPOSES ONLY. PRODUCTION DIMENSIONS AND TOLERANCES IN ACCORDANCE WITH DRAWINGS REFERENCED IN MIL-F-10884.
2. IN THE EVENT OF A CONFLICT BETWEEN THE TEXT OF THIS DOCUMENT AND THE REFERENCES CITED HEREIN, THE TEXT OF THIS DOCUMENT SHALL TAKE PRECEDENCE.
3. UNLESS OTHERWISE SPECIFIED, ISSUES OF REFERENCE, DOCUMENTS ARE THOSE IN EFFECT AT THE TIME OF SOLICITATION.
4. MS27980 SUPERSEDES AN227.
5. PART NUMBERS LISTED ARE THOSE BASED ON CURRENT GOVERNMENT USAGE. OTHER PART NUMBERS MAY ALSO BE OBTAINED.

PREPARING ACTIVITY: DLA-IS CUSTODIANS: ARMY- NAVY- AS AIR FORCE- B2 DLA- REVIEW: AR, AT, AV, ER, MC, NE, WS, SM PROJECT NUMBER: 5325-0330 DISTRIBUTION STATEMENT A. Approved for public release; distribution is unlimited.	MILITARY SPECIFICATION SHEET TITLE FASTENERS, SNAP, STYLE 2A (SMALL WIRE SPRING CLAMP TYPE)	SPECIFICATION SHEET NUMBER MS27981 13 JUN 85 REV C SUPERSEDING MS27981 B 5 MAY 71 (SEE NOTE 4.) AMSC- N/A FSC 5325
		Page <u>3</u> of <u>3</u>