

INCH-POUND

MS27769B
 9 June 2011
 SUPERSEDING
 MS27769A
 20 April 1979

DETAIL SPECIFICATION SHEET

PLUG, PIPE, COUNTERSINK HEX HEAD

This specification is approved for use by all Departments and Agencies of the Department of Defense.

The requirements for acquiring the product described herein shall consist of this specification sheet and SAE-AS4842.

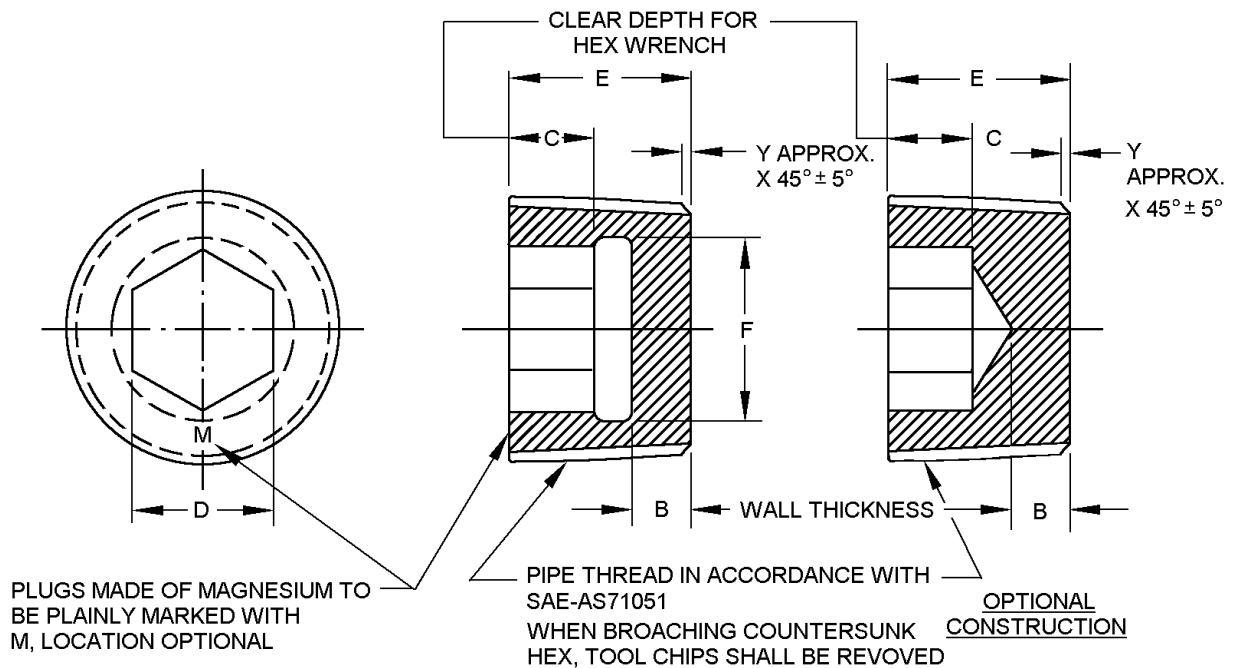

FIGURE 1. Pipe, plug.

MS27769B

Dash number	A Pipe thread SAE-AS71051	B Min inches (mm)	C Min inches (mm)	D inches (mm)	
				Min	Max
1	1/16- 27 ANPT	.094 (2.39)	.094 (2.39)	.1563 (3.970)	.1582 (4.018)
2	1/8-27 ANPT		.125 (3.18)	.1875 (4.763)	.1895 (4.813)
3	1/4-18 ANPT	.125 (3.18)	.219 (5.56)	.2500 (6.350)	.2520 (6.401)
4	3/8-18 ANPT			.3125 (7.938)	.3155 (8.014)
5	1/2-14 ANPT		.312 (7.92)	.3750 (9.525)	.3780 (9.601)
6	3/4-14 ANPT		.328 (8.33)	.5625 (14.288)	.5655 (14.364)
7	1-11 ANPT		.438 (11.13)	.6250 (15.875)	.6290 (15.977)
8	1-1/4-11 ANPT		.453 (11.51)	.7500 (19.050)	.7540 (19.152)

Dash number	E inches (mm)	F Max Diameter inches (mm)	Y inches (mm)
1	.270 (6.86)	.187 (4.75)	.030 (0.76)
2	.270 (6.86)	.244 (6.20)	
3	.410 (10.41)	.326 (8.28)	.050 (1.27)
4	.410 (10.41)	.400 (10.16)	
5	.540 (13.72)	.463 (11.76)	.060 (1.52)
6	.550 (13.97)	.681 (17.30)	
7	.690 (17.53)	.775 (19.69)	.080 (2.03)
8	.710 (18.03)	1.072 (27.23)	

NOTES:

1. Dimensions are in inches.
2. Metric equivalents are given for information only.
3. Unless otherwise specified tolerances are ± 0.010 inch (0.25 mm).
4. Surface roughness shall be 125 Ra max, see ASME B46.1. Machined surfaces shall be finished to 125μ in Ra, forged surfaces shall be 250μ inches Ra, unless otherwise specified on the figures. Surface finish shall be in accordance with ASME B46.1.
5. Break sharp edges, remove all hanging burrs and slivers.

FIGURE 1. Pipe, plug - Continued.

REQUIREMENTS:

Pipe plug shall be as specified on figure 1.

Procurement specification: SAE-AS4842.

Materials:

Steel shall be in accordance with SAE-AMS6382 (alloy 4140), hardened (oil quench) and temper, Rockwell hardness C26-32.

Copper alloy shall be in accordance with ASTM B16/B16M alloy C36000, half hard or ASTM B124/B124M alloy C37700.

Aluminum alloy 7075-T73 shall be in accordance with ASTM B211 or SAE-AMS-QQ-A-225/9.

MS27769B

Magnesium alloy AZ31B shall be in accordance with ASTM B107/B107M.

Corrosion resistant steel (CRES), type 347, shall be in accordance with SAE-AMS5646. CRES, type 321 shall be in accordance with SAE-AMS5645.

Titanium alloy shall be in accordance with SAE-AMS4928 (6Al-4V annealed).

Materials and finishes designators shall be in accordance table I.

TABLE I. Material and finish designators.

Designator	Material	Finish
Blank	Steel	Carbon steel cadmium plated in accordance with SAE-AMS-QQ-P-416, type II, class 2
A	Steel	Zinc plating in accordance with ASTM B633; type VI, Fe/Zn 5
C	Copper alloy	See Procurement Specification
M	Magnesium alloy <u>2/</u>	Magnesium finish in accordance with SAE-AMS-M-3171, Type III
R	CRES, alloy 321	See Procurement Specification
S	CRES, alloy 347	See Procurement Specification
T	Titanium alloy <u>1/</u>	Cold finished in accordance with SAE-AMS2241
U	Unplated steel	See Procurement Specification
W	Aluminum	See Procurement Specification

1/ Titanium shall not be used in oxygen systems.

2/ Magnesium alloy plugs shall not be used in hydraulic systems or valves. Magnesium metal shall not be used in oxygen systems. In addition, its alloys are not to be used except in areas with minimal exposure to corrosive environments. Reactivity with halogenated compounds constrains its use with lubricants containing chlorine and fluorine.

Part or Identifying Number (PIN): The PIN consists of the letters "MS," the specification sheet number, a dash or letter from table 3 to designate the material type, and a number to designate pipe plug size. Unassigned PIN's shall not be used.

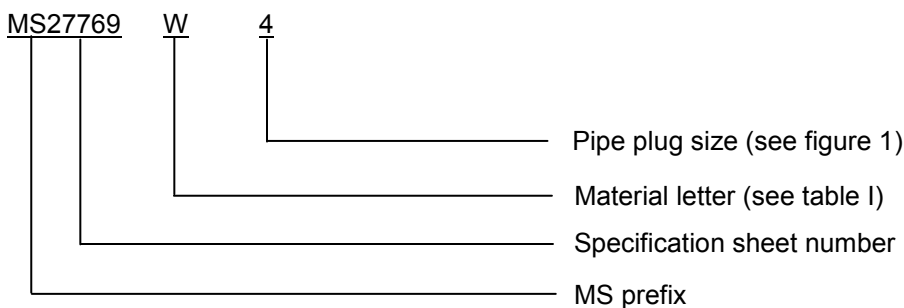

PIN example: MS27769W4 indicates a pipe plug, aluminum alloy 7075-T73, 3/8 -18 ANPT.

Cadmium is not recommended. To the users of this document, it is recommended that the use of carbon steel material with cadmium plating be used only when other materials and finishes specified in this document cannot meet performance requirements.

MS27769B

Supersession data: Aluminum alloy 2014 "D" designator has been replaced by aluminum alloy 7075-T73 "W" designator.

Changes from previous issues. Marginal notations are not used in this revision to identify changes with respect to the previous issue due to the extent of the changes.

Referenced documents. In addition to SAE-AS4842, this document references the following:

ASME B46.1	SAE-AMS-QQ-P-416
ASTM B16/B16M	SAE-AMS2241
ASTMB107/B107M	SAE-AMS4928
ASTM B124/B124M	SAE-AMS5645
ASTM B211	SAE-AMS5646
ASTM B633	SAE-AMS6382
SAE-AMS-M-3171	SAE-AS71051
SAE-AMS-QQ-A-225/9	

CONCLUDING MATERIAL

Custodians:

Army - AV
Navy - AS
Air Force - 99
DLA - CC

Preparing activity:

DLA - CC

(Project 4730-2011-063)

Review activities:

Navy - MC, SH
Air Force - 71

NOTE: The activities listed above were interested in this document as of the date of this document. Since organizations and responsibilities can change, you should verify the currency of the information above using the ASSIST Online database at <https://assist.daps.dla.mil>.