

FED. SUP CLASS
1670

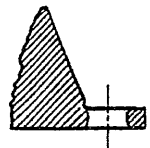

SECTION A-A

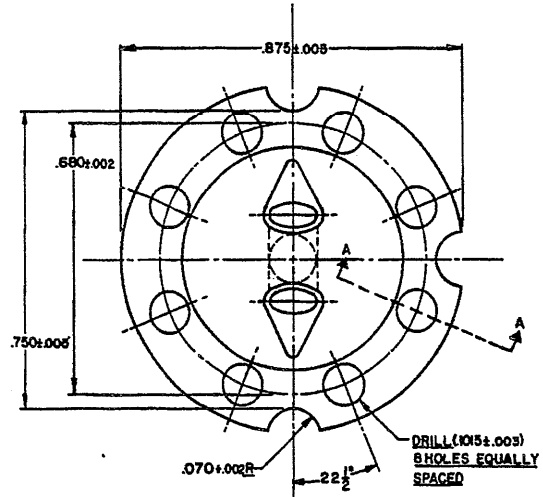
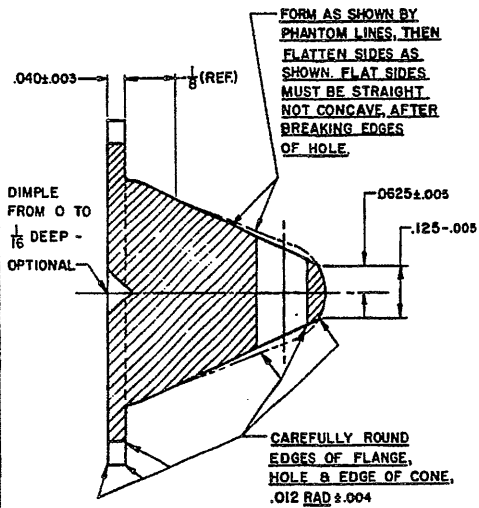
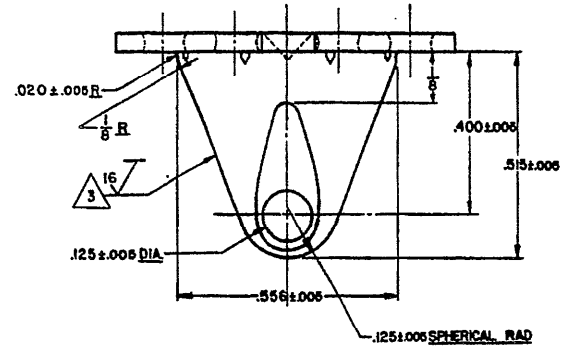

User activities: AS
 Review activities:
 USAF - B2
 ARMY - GL AV
 NAVY - AS

DASH NO.	MATERIAL
-1	SEE NOTE
-2	SEE NOTE

MS27763-2 IS FOR AIRCRAFT DECELERATION PARACHUTE APPLICATIONS

- NOTES:
- MATERIAL: BRASS, COMP 360, 1/2 HARD, QQ-B-626.
 - MATERIAL: STEEL BAR, CORROSION RESISTING, TYPE 303SE QQ-S-764.
 - SURFACE ROUGHNESS IN ACCORDANCE WITH ANS 46.1.
 - DIMENSIONS SHALL BE IN INCHES UNLESS OTHERWISE SPECIFIED. TOLERANCES: FRACTIONS ± 1/64, ANGLES ± 1°.
 - FINISH: MS27763-1 ONLY. ALL OVER WITH CHROMIUM PLATE, TYPE II, CLASS 2, QQ-C-320, EXCEPT THAT TOTAL THICKNESS OF NICKEL AND CHROME OR COPPER, NICKEL AND CHROME PLATE SHALL BE .0025 MINIMUM.
 - FOR DESIGN PURPOSES, THIS STANDARD TAKES PRECEDENCE OVER PROCUREMENT DOCUMENTS REFERENCED HEREIN.
 - REFERENCED DOCUMENTS SHALL BE OF THE ISSUE IN EFFECT ON DATE OF INVITATION FOR BID

This military standard is mandatory for use by all Departments and Agencies of the Department of Defense. Selection for all new engineering and design applications and for repetitive use shall be made from this document.

APPROVED BY: JVAJ 1970 REVISED

P.A. USAF-82 Other Cast Army - GL Navy - AS	TITLE CONE - RELEASING, PARACHUTE PACK	MILITARY STANDARD
		MS 27763
PROCUREMENT SPECIFICATION MIL-H-7195	SUPERSEDES: USAF DWG. 5086152	SHEET OF