

FED. SUP CLASS
5930

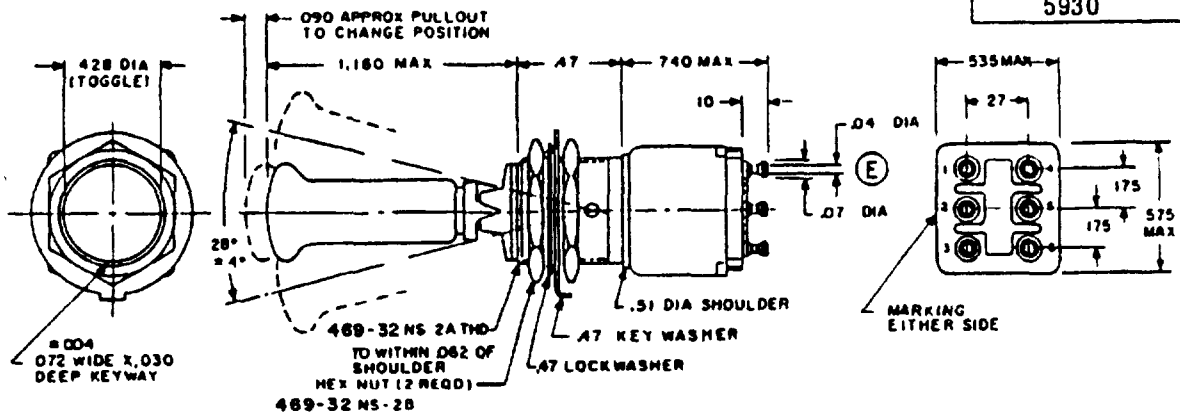

NOTES:

1. Dimensions are in inches.
2. Metric equivalents are given for general information only.
3. Unless otherwise specified, tolerance is $\pm .020$ (0.51 mm) on two place decimals, and $\pm .005$ (0.13 mm) on three place decimals.
4. For hardware detail specifications, see supplement of MIL-S-83731.
5. Configuration of switch chase is optional provided maximum dimensions specified are not exceeded.

DETAIL REQUIREMENTS (E)

LOCKING COMBINATIONS (KEYING SIDE)

A LOCKED IN THREE POSITIONS	B LOCKED IN CENTER AND DOWN POSITION (KEYING SIDE)	D LOCKED OUT OF CENTER POSITION (KEYING SIDE)	E LOCKED IN CENTER POSITION (KEYING SIDE)	F LOCKED IN UP POSITION (OPPOSITE KEYING)	G LOCKED IN DOWN POSITION (KEYING SIDE)	H LOCKED OUT OF CENTER AND DOWN POSITION (KEYING SIDE)
J LOCKED OUT OF CENTER AND UP POSITION (OPPOSITE KEYING)	K LOCKED IN CENTER AND UP POSITION (OPPOSITE KEYING)	L LOCKED OUT OF DOWN POSITION (KEYING SIDE)	M LOCKED OUT OF AND INTO UP POSITION (OPPOSITE KEYING)	N LOCKED OUT OF UP POSITION (OPPOSITE KEYING)	P LOCKED OUT OF AND INTO DOWN POSITION (KEYING SIDE)	FIGURES A THRU P DO NOT REPRESENT DETAILS OF CONSTRUCTION THEY SCHEMATICALLY ILLUSTRATE LOCKING CONFIGURATIONS A-H AND P.

Canceled MS part number 1/	Substitute part number 1/	Available locking combinations	Circuits made with toggle lever in			
			Keying side 1-2 4-5	Center position	Opposite keying side 2-3 5-6	
MS27754-1	MS27754-34	All	On	2-3 on 4-5	On	
-2	-35	E, F, K, L, M, N	Mom-On	2-3 on 4-5	On	
-3	-36	E, L, N	Mom-On	2-3 on 4-5	Mom-On	
-4	-38	All	-On	1-2 on 5-6	On	
-5	-39	E, F, K, L, M, N	Mom-On	1-2 on 5-6	On	
-6	-40	E, L, N	Mom-On	1-2 on 5-6	Mom-On	

1/ The cancelled part numbers are no longer procurable; the substitute part numbers have a lower dielectric withstanding voltage at reduced barometric pressure (see 2 below).

(E) denotes changes

PA Air Force 85	INTERNATIONAL INTEREST	TITLE	MILITARY STANDARD
Other Cust Army-ER Navy-AS		SWITCH, TOGGLE, MINIATURE, DOUBLE POLE, TOGGLE SEAL, LEVER LOCK	MS27754
Procurement Specifications MIL-S-83731	SUPERSEDES		SHEET 1 OF 2

AMSC N/A

5930-1378-08

DISTRIBUTION STATEMENT A. Approved for public release; distribution is unlimited.

Viewer Activity: Air Force 11, 99 User Activity:
Army AV, EA
Navy EC
DLA ES

This military standard is approved for use by all Departments and Agencies of the Department of Defense. Selection for all new engineering and design applications and for repetitive use shall be made from this document.

APPROVED 29 Feb 1972 REVISED (A) 5 Oct 1972 (B) 25 Apr 1975 (C) 14 Aug 1984 (D) 16 Feb 1987 (E) 20 May 1988

FED SUP CLASS
5930

Inches	mm	Inches	mm	Inches	mm
.004	0.13	.175	4.45	.535	13.59
.030	0.76	.240	6.10	.575	14.61
.040	1.02	.27	6.86	.690	17.53
.070	1.78	.469	11.91	.740	18.80
.072	1.83	.47	11.94		
.010	2.5	.51	12.95		

NOTES:

1. All switches on this standard are designed so that the movement of the switch mechanism is opposite to that of the toggle lever.
2. Test voltage for dielectric withstanding voltage at reduced barometric pressure, shall be 400 V rms minimum.
3. Electrical endurance shall be performed for 30,000 cycles.
4. Mechanical endurance shall be performed 50,000 cycles at -65°C and then 50,000 cycles at 85°C.
5. Intermediate current shall be performed for 30,000 cycles.
6. Terminals shall be molded into the switch case and shall accommodate no. 18 awg wire.
7. Locking arrangement: Positive locking shall be accomplished and shall prevent motion of the toggle lever until the locking mechanism is manually released.
8. The force required to release the locking mechanism shall be 3 to 5 pounds.
9. The locking means at the top of the toggle bushing shall be capable of withstanding a torque of 20 lb. inch applied in both directions immediately following the humidity test.
10. Maximum weight shall be .045 lb.
11. Electrical ratings for 28 volts dc and 115 volts ac at 400 Hz.
Lamp load = 1 ampere, resistive load = 5 amperes, inductive load = 2 amperes.
- (E) 12. In the event of a conflict between the text of this standard and the reference cited herein, the text of this standard shall take precedence.
- (E) 13. Referenced Government documents of the issue listed in that issue of the Department of Defense Index of Specifications and Standards (DODISS) specified in the solicitation form a part of this standard to the extent specified herein.
14. Part number example: MS27754-36L (locking combination "L").

This military standard is approved for use by all Departments and Agencies of the Department of Defense. Selection for all new engineering and design applications and for repetitive use shall be made from this document.

SHEET 1 AND 2

For changes see

REVISED (E)

APPROVED

P A Air Force 85 Other Cust Army-ER Navy-AS	INTERNATIONAL INTEREST	TITLE SWITCH, TOGGLE, MINIATURE, DOUBLE POLE, TOGGLE SEAL, LEVER LOCK	MILITARY STANDARD MS 27754
Procurement Specifications MIL-S-83731	SUPERSEDES	SHEET 2	OF 2