

FED. SUP CLASS
5935

Reviewer activities: Army MU
Navy EC
Air Force 11, 15, 17, 80
DSA-ES

User activities: Army
Navy
Air Force

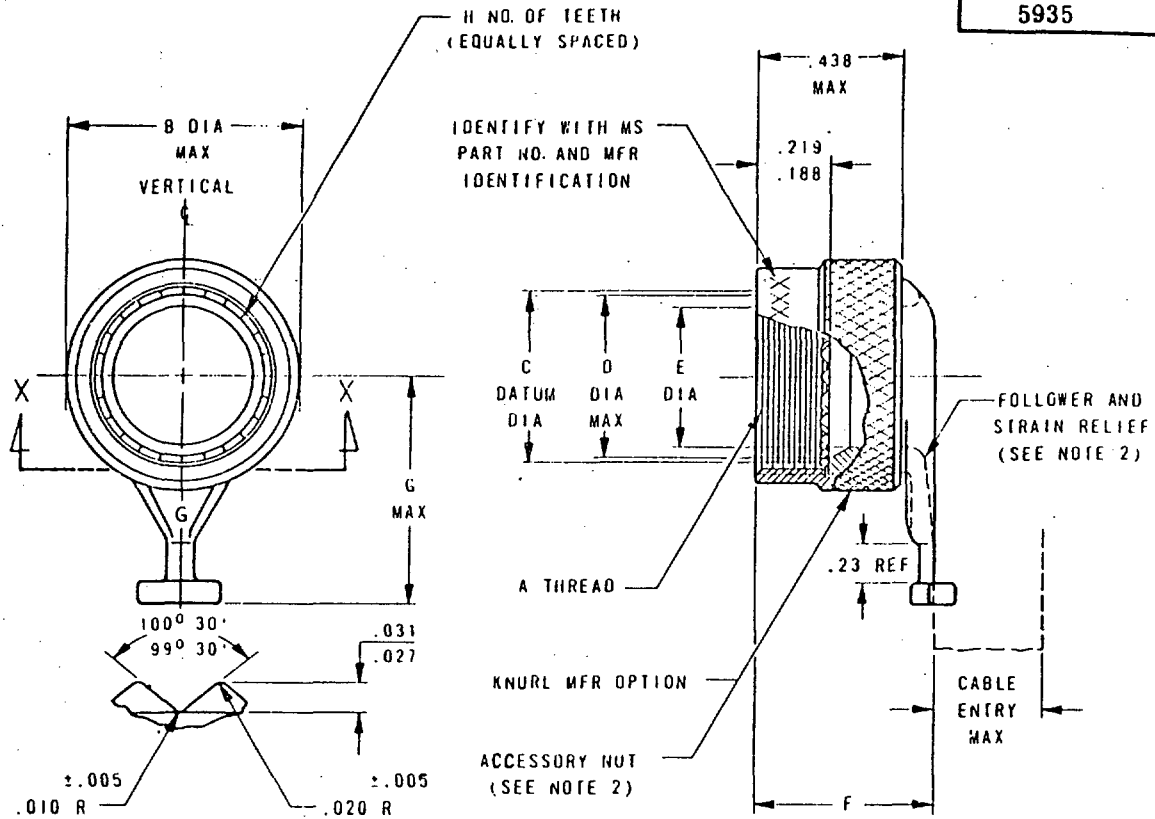

CANCELED - FOR PROCUREMENT USE
MIL-C-85049/63 ©

DASH NO.	FITS SHELL OF CONNECTOR		A THREAD CLASS 2B	B DIA MAX	C DATUM DIA	D DIA MAX	E DIA ±.005	F MAX	G MAX	H NO. OF TEETH	CABLE ENTRY MAX
	MIL-C-38999 SERIES II	SERIES I									
-08	8	9	.4375-28 UNEF	.687	.366	.347	.269	.69	1.22	12	.264
-10	10	11	.5625-24 UNEF	.782	.487	.472	.397	.69	1.29	16	.392
-12	12	13	.6875-24 UNEF	.937	.609	.586	.511	.69	1.62	20	.506
-14	14	15	.8125-20 UNEF	1.050	.731	.711	.636	.69	1.66	24	.631
-16	16	17	.9375-20 UNEF	1.239	.853	.836	.761	.69	1.72	28	.756
-18	18	19	1.0625-18 UNEF	1.378	.975	.942	.850	.69	1.72	32	.845
-20	20	21	1.1875-18 UNEF	1.500	1.097	1.067	.975	.69	1.79	36	.970
-22	22	23	1.3125-18 UNEF	1.631	1.218	1.192	1.100	.69	1.85	40	1.095
-24	24	25	1.4375-18 UNEF	1.825	1.340	1.309	1.225	.69	1.91	44	1.220

INCHES	MM	INCHES	MM	INCHES	MM	INCHES	MM	INCHES	MM	INCHES	MM
.005	.13	.366	9.30	.609	15.47	.8125	20.64	1.067	27.10	1.3125	33.34
.010	.25	.392	9.92	.631	16.03	.836	21.23	1.095	27.81	1.340	34.04
.020	.51	.397	10.08	.636	16.15	.845	21.46	1.097	27.86	1.378	35.00
.027	.69	.4375	11.11	.687	17.45	.850	21.59	1.100	27.94	1.4375	36.51
.031	.79	.438	11.13	.6875	17.46	.853	21.67	1.1875	30.16	1.500	38.10
.188	4.78	.472	11.99	.69	17.53	.937	23.80	1.192	30.28	1.62	41.15
.219	5.56	.487	12.37	.711	18.06	.9375	23.81	1.218	30.94	1.631	41.43
.23	5.84	.506	12.85	.731	18.57	.942	23.93	1.220	30.99	1.66	42.16
.264	6.71	.511	12.98	.756	19.20	.970	24.64	1.225	31.12	1.72	43.69
.269	6.83	.5625	14.29	.761	19.33	.975	24.77	1.239	31.47	1.79	45.47
.347	8.81	.586	14.88	.782	19.86	1.050	26.67	1.29	32.77	1.85	46.99
						1.0625	26.99	1.309	33.25	1.91	48.51

© For changes see sheet 1

P.A. AF-85	International Interest	TITLE	MILITARY STANDARD
Other Cust Army - CR Navy - AS		CLAMP, STRAIN RELIEF, 90°	MS27670
Procurement Specification MIL - C - 38999		SUPERSEDES:	SHEET 1 OF 2

AMSC N/A 672 (Coordinated) PREVIOUS EDITIONS OF THIS FORM ARE OBSOLETE.

5935-3614-03

DISTRIBUTION STATEMENT A. Approved for public release; distribution is unlimited.

APPROVED 10 NOV 72 REVISED 3 APRIL 74 © 18 DEC 74 © 18 MAR 88

This military standard is mandatory for use by all Departments and Agencies of the Department of Defense. Selection for all new engineering and design applications and for repetitive use shall be made from this document.

NOTES:

1. Dimensions are in inches.
2. Complete strain relief unit consists of accessory nut and a follower with strain relief arm. The accessory nut shall be captivated to the follower and free to rotate.
3. Materials: Aluminum alloy.
4. Finish on strain relief hardware shall be:
 - B. Cadmium plate per QQ-P-416, Type II, class 3: color dull olive drab.
 - C. Anodic, type II, in MIL-A-8625, class 2, color - black.
 - F. Electroless nickel per MIL-C-26074, class 3 or 4, grade B.
5. Strain relief unit is to be used with MS17821-1 plastic strap, MIL-T-713 lacing twine or MIL-T-43435 lacing tape or equivalent.
6. Each strain relief unit shall be identified with manufacturer's name or trademark and the appropriate MS part number.
7. Qualification: One sample in each size range (lower, middle, and upper) for which qualification is desired shall be tested. Each sample shall be assembled to a qualified connector or a connector undergoing qualification. The connector insert arrangement shall be of the maximum number of contacts, using the appropriate wire size approaching the minimum wire diameter. Testing shall be as follows and shall be performed in the sequence listed:
 - A. Examination of product.
 - B. Magnetic permeability - The relative magnetic permeability shall be less than 2.0 when checked with an indicator conforming to MIL-I-17214. Wired assemblies shall not be carrying current.
 - C. Vibration - in accordance with method 2005 of MIL-STD-1344, test condition III.
 - D. Shock - in accordance with method 2004 of MIL-STD-1344, test condition A.
 - E. Salt spray (corrosion) - in accordance with method 1001 of MIL-STD-1344, condition B.
 - F. Test report: Three copies of the Test Report shall be submitted to the qualification agency together with new untested units of the same quantity and production lot as used for qualified by similarity. The test report shall include the following:
 1. Actual results of all qualification measurements required by the specification.
 2. Certifications of all materials and finishes.
8. Quality assurance:
 - A. Examination of product.
9. The items described herein are covered by patent 3, 603, 913 and 3, 732, 527.
10. Any portion of this standard which may be covered by copyrights owned by Glenair, Inc., is reprinted with the express permission of said company.

Reviewer activities: Army MU Navy EC Air Force 11, 15, 17, 80 DSA-ES
 User activities: Army MU Navy EC Air Force 11, 15, 17, 80 DSA-ES
 This military standard is mandatory for use by all Departments and Agencies of the Department of Defense. Selection for all new engineering and design applications and for repetitive use shall be made from this document.

STRAIN RELIEF PART NUMBER

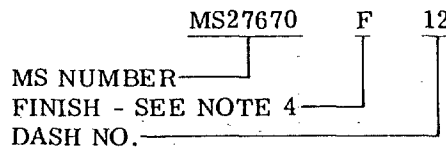

P.A. AF-85	International Interest	TITLE CLAMP, STRAIN RELIEF, 90°	MILITARY STANDARD
Other Cus CR Army -AS Navy -AS			MS27670
Procurement Specification MIL - C - 38999		SUPERSEDES:	SHEET 2 OF 2