

FED. SUP CLASS  
4730

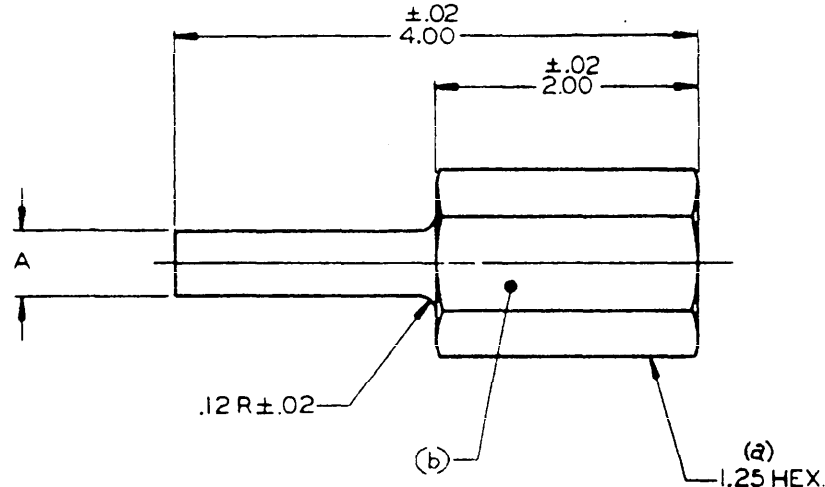

DIMENSIONS IN INCHES UNLESS OTHERWISE SPECIFIED:  
 RADIUS OR BREAK ALL CORNERS  $.005$ ,  $+.005/-0.000$ .  
 REMOVE ALL BURRS AND SLIVERS. SURFACE ROUGHNESS  
 PER ANSI B46.1-1962 NOT TO EXCEED 125 AA.  
 ALL DIAMETERS SHALL BE CONCENTRIC WITHIN  $.005$  TIR.  
 THIS PART FOR USE WITH MIL-H-83298 HOSE.  
 THIS STANDARD TAKES PRECEDENCE OVER DOCUMENTS  
 REFERENCED HEREIN.  
 REFERENCED DOCUMENTS SHALL BE OF THE ISSUE IN EFFECT  
 ON DATE OF INVITATION FOR BID.

- (a) USE COMMERCIAL STOCK SIZE TOLERANCE
- (b) MS PART NO. AND MANUFACTURERS TRADEMARK  
HERE.

MATERIAL : STEEL PER AISI S2  
 HARDNESS SHALL BE ROCKWELL HRC: 58 TO 60  
 FINISH : BLACK OXIDE PER AMS 2485

MS PART NUMBER	A $+0.000$ $-0.005$
MS27639-4C	.315
MS27639-6C	.410
MS27639-8C	.505
MS27639-10C	.640

This standard has been approved by the Department of the Air Force and is mandatory for use by that activity. All other military activities are required to employ this standard where suitable.

APPROVED 17 Mar 71

P.A. USAF-11	TITLE	MILITARY STANDARD
Other Cust	DISASSEMBLY TOOL	MS27639
Procurement Specification MIL-F-83296	SUPERSEDES:	SHEET   OF