

INCH-POUND

MS27615E  
 6 February 2004  
 SUPERSEDING  
 MS27615D (USAF)  
 7 September 1990

DETAIL SPECIFICATION SHEET

CONNECTORS, ELECTRICAL, PLUG,  
 RATCHET LOCK COUPLING, FIREWALL SERIES

Inactive for Air Force new design after 14 November 1977.  
 Use MIL-DTL-83723 Series III, class K, which is interchangeable.

This specification is approved for use by all Departments  
 and Agencies of the Department of Defense.

The requirements for acquiring the product described herein  
 shall consist of this specification sheet and MIL-DTL-26500.

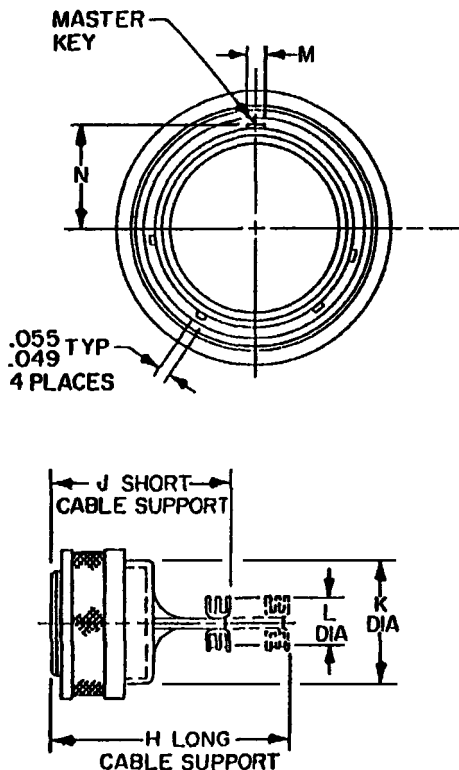
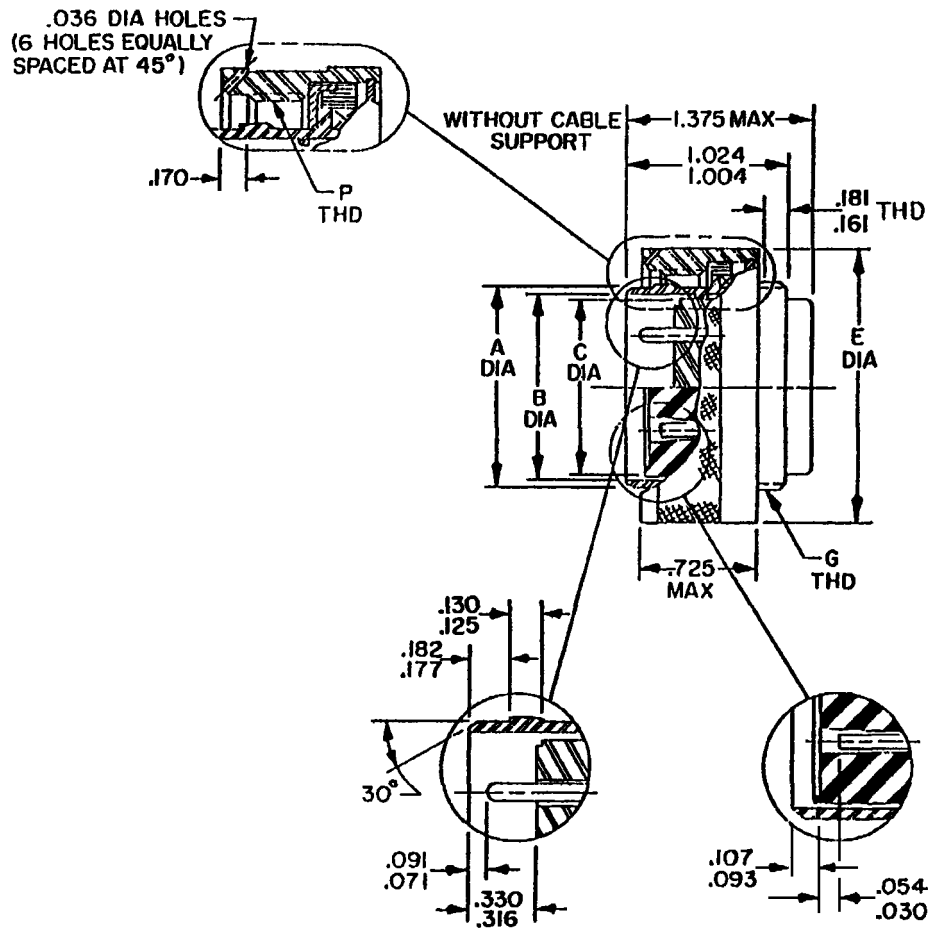

FIGURE 1. Plug dimensions.

MS27615E



Inches	mm	Inches	mm
.030	.076	.161	4.09
.036	0.91	.170	4.32
.049	1.24	1.77	4.50
.054	1.37	.181	4.60
.055	1.40	.182	4.62
.071	1.80	.316	8.03
.091	2.31	.330	8.38
.093	2.36	.725	18.42
.107	2.72	1.004	25.50
.125	3.18	1.024	26.01
.130	3.30	1.375	34.92

FIGURE 1. Plug dimensions – Continued.

MS27615E

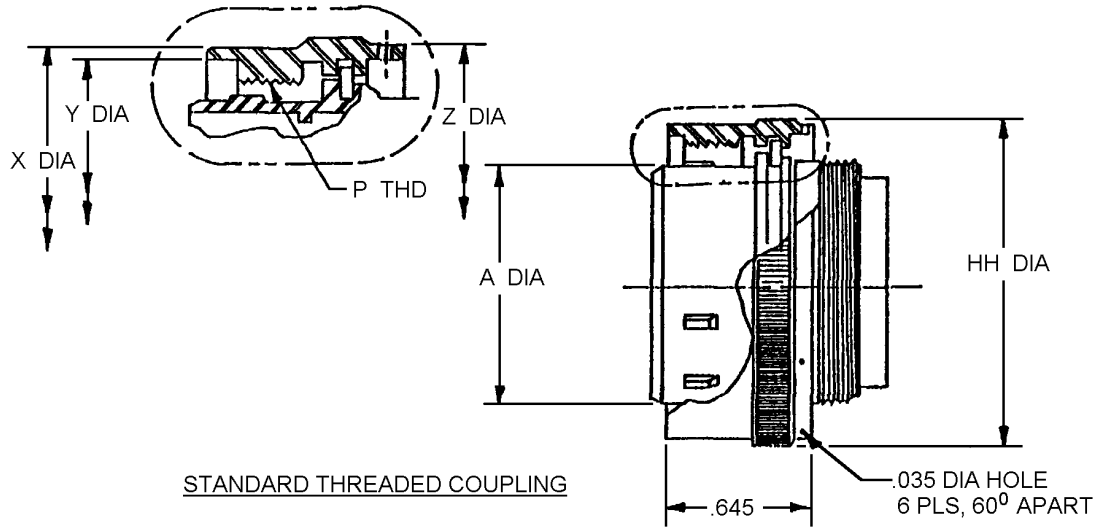
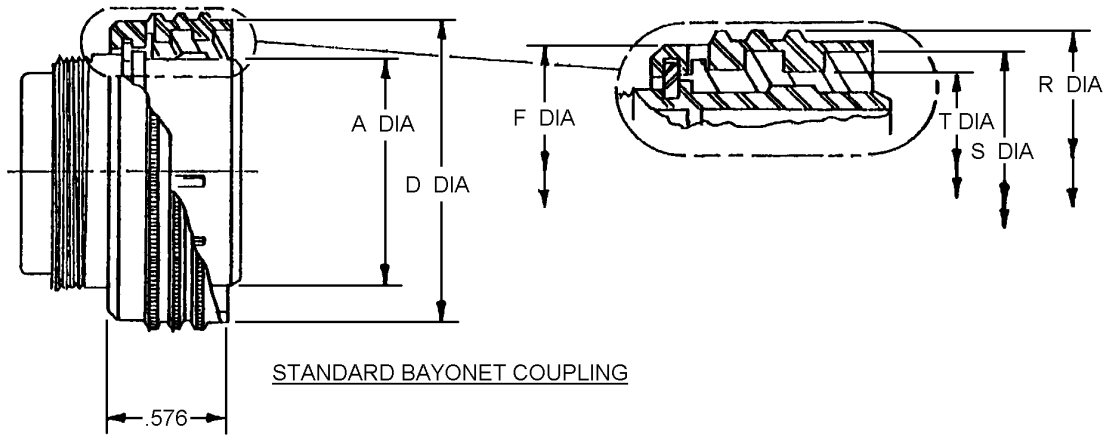

FIGURE 1. Plug dimensions – Continued.

MS27615E



Inches	mm
.035	.89
.576	14.63
.645	16.38

FIGURE 1. Plug dimensions – Continued.

## MS27615E

Shell size (see note 4)	A dia $\pm .005$ (0.13)	B dia $+ .003$ (0.08) $- .006$ (0.15)	C dia max	D dia $\pm .005$ (0.13)	E dia $\pm .005$ (0.13)
12	.696 (17.68)	.634 (16.10)	.508 (14.73)	N/A	1.11 (28.2)
14	.765 (19.43)	.703 (17.86)	.627 (15.92)	1.059 (26.40)	1.175 (29.84)
16	.892 (22.66)	.830 (21.08)	.754 (19.15)	1.186 (31.12)	1.302 (33.07)
18	.998 (25.35)	.936 (23.77)	.860 (21.84)	1.292 (32.82)	1.408 (35.76)
22	1.248 (31.70)	1.186 (30.12)	1.110 (28.19)	1.542 (39.17)	1.658 (42.11)
24	1.373 (34.87)	1.311 (33.30)	1.235 (31.37)	1.667 (42.34)	.178 (45.2)
28	1.623 (41.22)	1.561 (39.65)	1.488 (37.80)	N/A	2.038 (51.76)

FIGURE 1. Plug dimensions – Continued.

## MS27615E

Shell size (see note 4)	F dia $\pm .005$ (0.13)	G 36NS-2A	H dia max	HH dia max	J max
12	N/A	.7334 (18.628)	2.045 (51.94)	1.086 (27.58)	N/A
14	1.016 (25.81)	.8032 (20.401)	2.145 (54.48)	1.149 (29.18)	1.875 (47.62)
16	1.143 (29.03)	.9302 (23.627)	2.245 (57.02)	1.275 (32.38)	1.875 (47.62)
18	1.249 (31.72)	1.0362 (26.319)	2.345 (59.56)	1.383 (35.13)	1.875 (47.62)
22	1.499 (38.07)	1.2862 (32.669)	2.575 (65.40)	1.633 (41.49)	1.875 (47.62)
24	1.624 (41.25)	1.4111 (35.842)	2.675 (67.94)	1.758 (44.65)	N/A
28	N/A	1.6611 (42.192)	2.645 (67.18)	2.008 (51.00)	N/A

FIGURE 1. Plug dimensions – Continued.

## MS27615E

Shell size (see note 4)	K dia	L dia	M ± .003 (0.008)	N ± .003 (0.08)	P UNEF-28	R dia max
12	.788 (20.02)	.435 (11.05)	.084 (2.13)	.370 (9.40)	.875-20 (22.22)	N/A
14	.862 (21.89)	.504 (12.80)	.084 (2.13)	.045 (10.29)	.937-20 (22.23)	1.087 (27.61)
16	.989 (25.12)	.686 (14.42)	.115 (2.92)	1.062-18 (26.97)	1.214 (30.84)	1.214 (30.84)
18	1.095 (27.81)	.794 (20.17)	.115 (2.92)	.521 (13.23)	1.187-18 (30.15)	1.320 (33.53)
22	1.345 (34.16)	1.038 (26.36)	.115 (2.92)	.646 (16.41)	1.437-18 (36.50)	1.570 (39.88)
24	1.595 (40.51)	1.162 (29.51)	.115 (2.92)	.708 (17.98)	1.562-18 (39.67)	1.695 (43.05)
28	1.845 (46.86)	1.412 (35.86)	.115 (2.92)	.833 (21.16)	1.812-16 (46.02)	N/A

FIGURE 1. Plug dimensions – Continued.

## MS27615E

Shell size (see note 4)	S dia $\pm .035$ (0.088)	T dia $+ .005$ (0.13) $- .000$ (0.00)	W $\pm .006$ (0.15)	X $\pm .005$ (0.13)	Y $\pm .004$ (0.10)	Z $\pm .004$ (.010)
12	N/A	N/A	N/A	.984 (25.0)	.928 (25.12)	.982 (24.94)
14	1.0055 (25.565)	.900 (22.86)	.282 (7.16)	.1.054 (26.77)	..998 (25.34)	..962 (24.43)
16	1.335 (28.790)	1.028 (26.11)	.402 (10.21)	1.181 (30.00)	1.125 (28.57)	1.089 (27.66)
18	1.2395 (31.483)	1.134 (28.08)	.556 (14.12)	1.287 (32.68)	1.231 (33.55)	1.195 (30.35)
22	1.4895 (37.833)	1.384 (35.15)	.608 (15.44)	1.537 (39.03)	1.481 (37.61)	1.445 (36.70)
24	1.6148 (41.016)	1.511 (38.38)	N/A	1.662 (42.21)	1.606 (40.79)	1.570 (39.87)
28	N/A	N/A	N/A	1.912 (48.56)	1.856 (47.14)	1.821 (46.22)

FIGURE 1. Plug dimensions – Continued.



## MS27615E

Weights of assembly (in pounds) less contacts and cable support.

Size	12	12	14	14	14	14	16	16	18	18	18
Configuration	03	12	04	07	12	15	10	24	08	14	31
Pin	.068	.066	.069	.067	.068	.069	.094	.086	.097	.095	.092
mm	1.73	1.68	1.75	1.70	1.73	1.75	2.39	4.72	2.46	2.41	2.34
Socket	.072	.071	.072	.071	.072	.073	.097	.093	.102	.101	.098
mm	1.83	1.80	1.83	1.80	1.83	1.85	2.46	2.36	2.59	2.56	2.49

Size	22	22	22	24	24	28	28	22	22
Configuration	19	12	55	30	43	40	42	12	55
Pin	.132	.135	.138	.160	.162	.209	.208	.135	.138
mm	3.35	3.43	3.51	4.06	4.11	5.31	5.28	3.43	3.51
Socket	.136	.140	.144	.165	.188	.211	.214	.140	.144
mm	3.45	3.56	3.66	4.19	4.78	5.36	5.44	3.56	3.66

## NOTES:

1. Dimensions are in inches.
2. Millimeters are in parentheses.
3. Metric equivalents are given for general information only.
4. From size 12 and 28 in bayonet series not released.

FIGURE 1. Plug dimensions – Continued.

## MS27615E

### REQUIREMENTS

Dimensions and configurations: See figure 1.

Connector mating: This connector mates with MS24264, MS24265, MS27034, MS27613 and MS27614.

The contacts shall be crimp type contacts and shall conform to MIL-C-39029.

Contacts are not assembled into the connectors, but are furnished separately in containers.

The contacts shall be crimped with a tool conforming to MIL-C-22520/1 crimping tool.

For insert arrangements and alternate insert (keying) positions. See MIL-STD-1554.

The dimensions and weight requirements shall be as specified in the tables shown on the MS drawings.

Dust caps are supplied for front and back end of the connectors.

When Part or Identifying Number (PIN) designates a cable support, the connector and cable support will be furnished unassembled.

Material and finishes:

- a. The shells shall be of stainless steel material. Type 300 series in accordance with DOD-F-24669/6 and shall be passivated in accordance with MIL-STD-171.
- b. The contacts shall be of telnic bronze and shall be rhodium plated in accordance with MIL-C-39029.
- c. The rigid insulation shall be of fired aluminum oxide (ceramic) material.
- d. Cable supports shall be of 310 stainless steel, casting alloy and shall be passivated in accordance with MIL-STD-171.
- e. Contact retainers: Material optional.
- f. Seals and grommets shall be of silicone rubber.

## MS27615E

For class K connectors:

- a. The connectors described herein shall meet all the environmental and electrical requirements of MIL-DTL-26500.
- b. In addition to the requirements of MIL-DTL-26500, the connectors shall meet the following requirements.
  1. Fireproof: A connector plug mated to its applicable receptacle assembly shall be mounted as used in service on a fixture fabricated in accordance with of MIL-DTL-5015 and subjected to a 1.093°C flame for a period of 60 minutes. The flame shall be directed at the connector, and shall completely encompass the connector. The temperature of the flame shall be measured at .250 inch, vertical distance from the rear of the connector. The flame shall be produced by using propane fuel with a high air-to-fuel mixture at a flow rate equivalent to an input of 33,000 to 37,000 BTU/HR. The assembly shall be vibrated continuously at 33 CPS with total excursion of .250 inch for 60 minutes. The contacts shall carry the following dc current for the first 5 minutes of the test.

Contact size	Amperes
12	41
16	22
20	7.5

During the next minute of test, 110/125 volts at 60 CPS shall be applied between adjacent contacts and between contacts and the shell without exceeding 2 amperes of line current. Throughout the test, there shall be no passing of Flames through the connector, nor shall there be any secondary combustion at the rear of the panel mounted connector.

There shall be no adapters or extensions other than the standard cable clamp assembled to the connectors during the fireproof test.

2. Insulation resistance, fireproof: After the flame test, the connectors shall be allowed to cool to room temperature, the mated connectors shall then be subjected to a test potential of 500 V dc. The insulation resistance of the connectors shall be greater than 2,000 megohms.
3. Dielectric withstanding voltage, fireproof. After exposure to the flame and insulation resistance tests, the mated connectors shall be subjected to 1500 V ac rms. Applied between adjacent contacts and the contacts closet to the shell, there shall be no evidence of breakdown or flashover.
4. Contact retention, fireproof after exposure to the flame, insulation resistance and dielectric withstanding tests, the individual contact locking mechanism shall withstand the axial loads specified in the table.

## MS27615E

Contact size	Axial load (lbs.) (fireproof)
12	23
16	18
20	12

The load shall be applied to the contact as specified in MIL-DTL-26500 and shall be applied at a rate of one pound per second.

All dimensions shown are in inches and are after plating dimensions. The four keys and/or keyways shall be within .004 of thru position relative to the master key.

The connector described in this MS drawing is classified as class K firewall connector. The shell sizes range from 12 to 28 and shall conform to the applicable portions of MIL-DTL-26500.

PIN example:

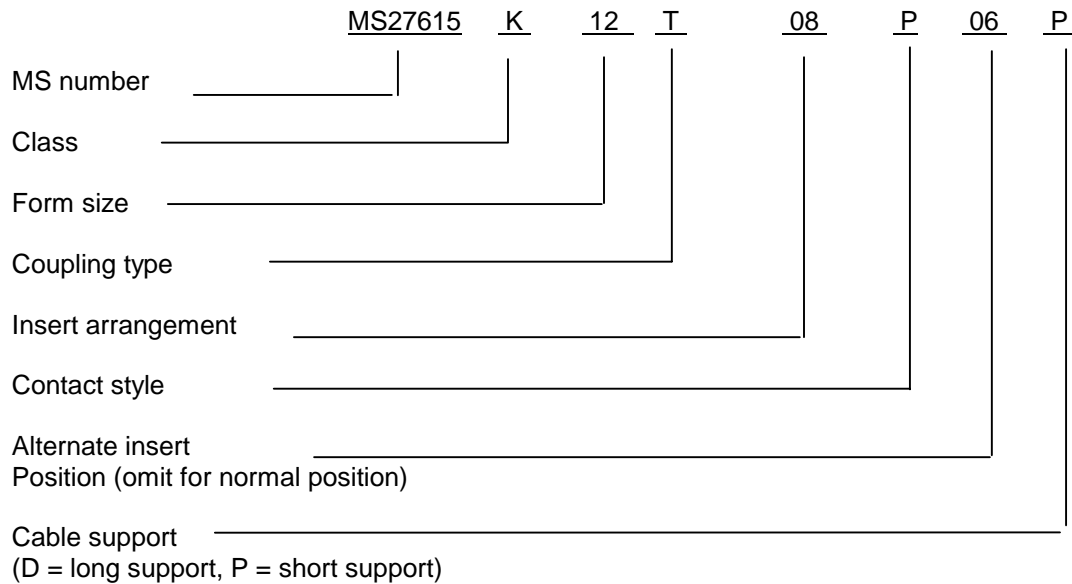

Changes from previous issue. Marginal notations are not used in this revision to identify the changes with respect to the previous issue due to the extent of the changes.

MS27615E

Referenced documents. In addition to MIL-DTL-26500, this document references the following:

DOD-F-24669/6  
MIL-C-22520/1  
MIL-C-39029  
MIL-DTL-5015  
MIL-STD-171  
MIL-STD-1554  
MS24264  
MS24265  
MS27034  
MS27613  
MS27614

CONCLUDING MATERIAL

Custodians:  
Air Force – 11  
DLA – CC

Preparing activity:  
DLA – CC

Review activity:  
Air Force – 99

(Project 5935–4419–016)

NOTE: The activities listed above were interested in this document as of the date of this document. Since organizations and responsibilities can change, you should verify the currency of the information above using the ASSIST Online database at <http://www.dodssp.daps.mil>.