

INCH-POUND

MS27469G
~~12 July 2002~~
 SUPERSEDING
 MS27469F
 2 January 1976

DETAIL SPECIFICATION SHEET

CONNECTORS, RECEPTACLE, ELECTRICAL, WALL MOUNTING
 FLANGE, SOLDER TYPE, HERMETIC SEAL, SERIES I

This specification is approved for use by all Departments
 and Agencies of the Department of Defense.

The requirements for acquiring the product described herein
 shall consist of this specification and MIL-DTL-38999.

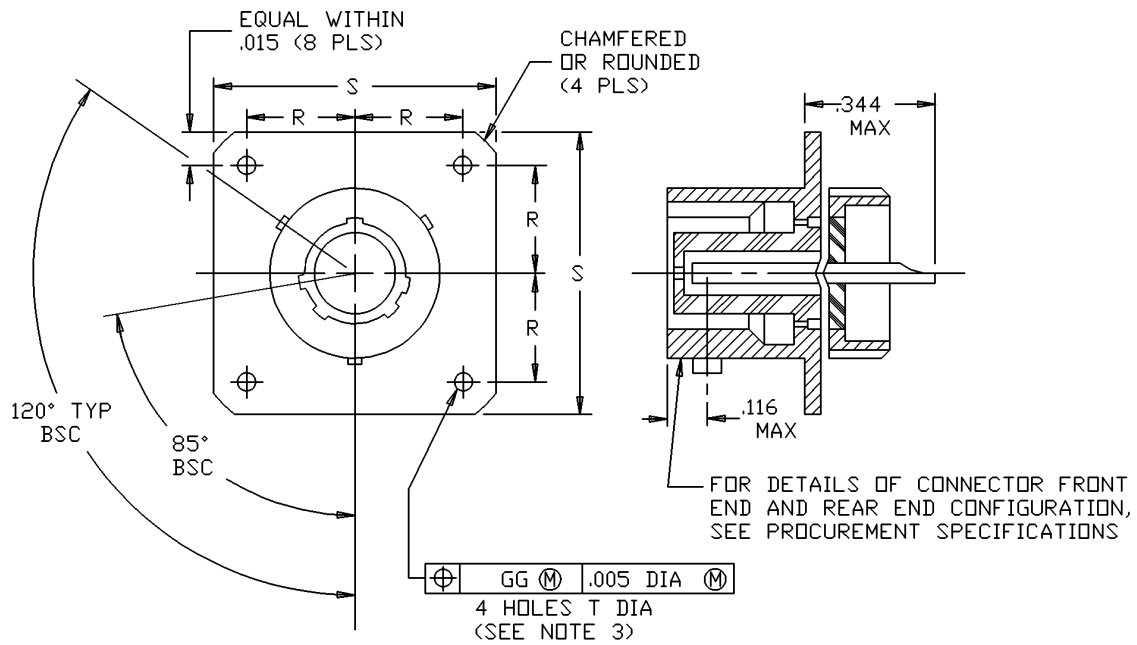

FIGURE 1. Receptacle, class Y.

MS27469G

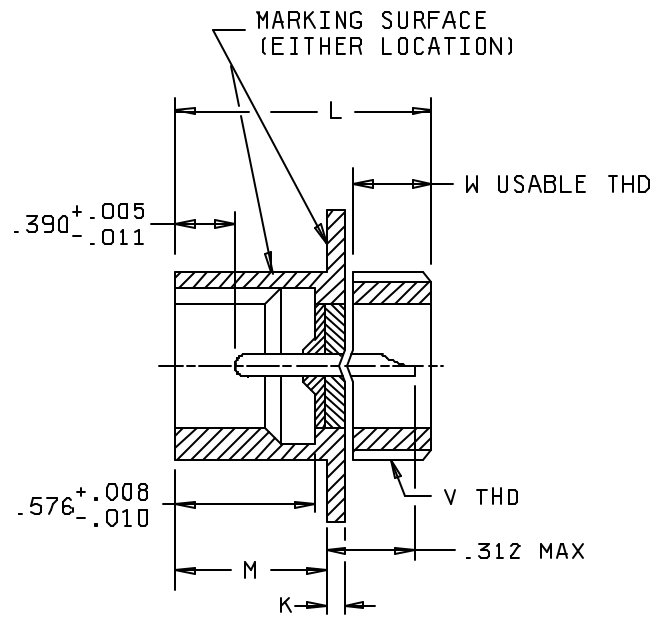

FIGURE 1. Receptacle, class Y - Continued.

MS27469G

Shell size	K + .031 - .000	L max	M + .031 - .000	R BSC	S ± .016	T dia + .010 - .005	W min full THD	V THD Class 2A UNEF (plated)
9	.062	1.093	.659	.3595	.938	.128	.250	.6875 – 24
11				.406	1.031			.8125 – 20
13				.453	1.125			.9375 – 20
15				.4845	1.219			1.0625 – 18
17				.531	1.312			1.1875 – 18
19				.578	1.438			1.3125 – 18
21				.625	1.562			1.4375 – 18
23				.6875	1.688			1.5625 – 18
25				.750	1.812			1.6875 – 18

Inches	mm	Inches	mm	Inches	mm	Inches	mm
.005	0.13	.128	3.25	.4845	12.31	1.031	26.19
.008	0.20	.147	3.73	.531	13.49	1.093	27.76
.010	0.25	.250	6.35	.576	14.63	1.125	28.58
.011	0.28	.312	7.92	.578	14.68	1.219	28.68
.015	0.38	.344	8.74	.625	15.88	1.312	33.32
.016	0.41	.3595	9.13	.659	16.74	1.438	36.53
.031	0.79	.390	9.91	.6875	17.46	1.562	39.67
.062	1.57	.406	10.31	.750	19.05	1.688	42.88
.116	2.95	.453	11.51	.938	23.83	1.812	46.02

NOTES:

1. Dimensions are in inches.
2. Metric equivalents are given for general information only.
3. The gauge features for GG shall be .010 (0.25 mm) smaller than the MMC size at basic location.
4. For main keyway and keyway positions, see MIL-DTL-38999.

FIGURE 1. Receptacle, class Y - Continued.

MS27469G

REQUIREMENTS:

Dimensions and configuration: See figure 1.
Interface dimensions shall conform to MIL-DTL-38999.
Mating connectors: MS27467, MS27661 and MS27653.
Insert arrangements: See MIL-STD-1560.

Part or Identifying Number (PIN) example:



CONCLUDING MATERIAL

Custodians:
Army - CR
Navy - AS
Air Force - 11
DLA - CC

Preparing activity:
DLA - CC

(Project: 5935-4394)

Review activities:
Army - AR, MI
Navy - EC, MC, OS
Air Force - 19, 99