

TYPICAL ASSEMBLY

DASH NO	*TR IDENT NO (REF)	THREAD T	A	C	D +.002 -.003	PACKING	VALVE CORE	VALVE CAP
-1	752	5/16 -24 UNF 3A	1.313	15/64	.250	MS9068-010	MIL-V-27317	ZZ-V-25 **MS20813 (B)
-2	753		2.000					
-3		3/8 -24 UNF 3A	1.313	19/64	.312	MS9068-011		
-4			2.000					

\* TR DENOTES TIRE & RIM ASSOCIATION

(B) \*\*MS20813 MANDATORY FOR NAVAL APPLICATION

MATERIAL: CORROSION RESISTANT STEEL COMP 303 PER SPEC MIL-S-7720.

TOLERANCES: UNLESS OTHERWISE SPECIFIED, FRACTIONS ± 1/64 DECIMALS ± .010, ANGLES ± 2°.

FINISH: TIN PLATE TO .0003 MIN THICKNESS, .0005 MAX THICKNESS PER MIL-T-10727. CADMIUM PLATE PER QQ-P-416, TYPE 2, CLASS 2, .0003 INCH MIN THICKNESS.

ADD T BEFORE DASH NUMBER FOR TIN PLATED VALVE.

ADD C BEFORE DASH NUMBER FOR CADMIUM PLATED VALVE.

- NOTES:
- (1) REFERENCED DOCUMENTS SHALL BE OF THE ISSUE IN EFFECT ON DATE OF INVITATIONS FOR BID.
  - (2) THIS STANDARD TAKES PRECEDENCE OVER DOCUMENTS REFERENCED HEREIN.
  - (3) ALL DIMENSIONS ARE IN INCHES.
  - (4) THE MS PART NUMBER CONSISTS OF THE MS NUMBER PLUS THE FINISH CODE & DASH NUMBER.  
EXAMPLE:
  - (5) ALL DIMENSIONS SHOWN APPLY AFTER PLATING.
  - (6) REMOVE ALL BURRS & BREAK ALL SHARP EDGES .005 MAX.
  - (7) IMPRESSION STAMP PART NUMBER IN 1/16 INCH CHARACTER PER MIL-STD-130.
  - (8) INSTALLATION TORQUE SHOULD BE SPECIFIED ON APPLICABLE DRAWINGS USED AND SHALL NOT EXCEED 60 INCH-POUNDS FOR THE -1 AND -2, AND 80 INCH-POUNDS FOR THE -3 AND -4 VALVES.
  - (9) THIS DOCUMENT HAS BEEN PROMULGATED BY THE DEPARTMENT OF DEFENSE AS THE MILITARY STANDARD TO LIMIT THE SELECTION OF THE ITEM, PRODUCT OR DESIGN COVERED HEREIN IN ENGINEERING, DESIGN AND PROCUREMENT. THIS STANDARD SHALL BECOME EFFECTIVE NOT LATER THAN 90 DAYS AFTER THE LATEST DATE OF APPROVAL SHOWN.

(B)

DENOTES CHANGE.

Review activities:  
Army AV  
Navy AS  
Air Force 11

This military standard is approved for use by all Departments and Agencies of the Department of Defense. Selection for all new engineering and design applications and for repetitive use shall be made from this document when applicable.

P.A. AIR FORCE 70 OTHER CUST ARMY - AV AIR FORCE 99 NAVY - AS	TITLE	MILITARY STANDARD
	VALVE SPECIAL, Aircraft Wheel	MS 27436
PROCUREMENT SPECIFICATION	SUPERSEDES	SHEET 1 OF 2

APPROVED 13 Sep 66 REVISED (A) 22 SEPT 1983 (B) 27 MAY 1985

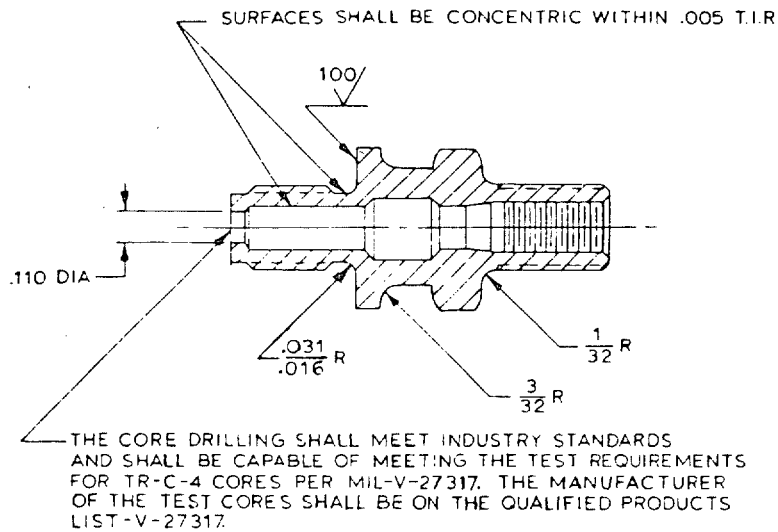
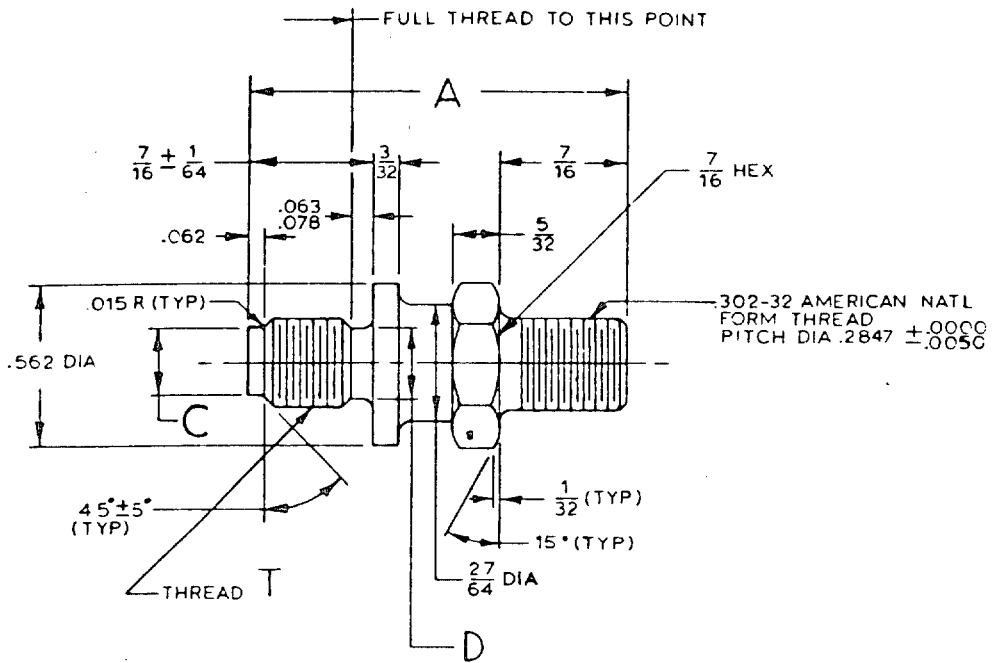

Review activities:  
Army AV  
Navy AS  
Air Force 11

This military standard is approved for use by all Departments and Agencies of the Department of Defense. Selection for all new engineering and design applications and for repetitive use shall be made from this document when applicable.

APPROVED 13 Sep 66 REVISED (B) For change See page 1

P.A. AIR FORCE 70	TITLE	MILITARY STANDARD
Other Cust ARMY AV AIR FORCE 99 NAVY AS	VALVE SPECIAL, Aircraft Wheel	MS 27436
PROCUREMENT SPECIFICATION	SUPERSEDES	SHEET 2 OF 2