

INCH-POUND

MS27084C
 25 September 2003
 SUPERSEDING
 MS27084B
 30 June 1972

DETAIL SPECIFICATION SHEET

ELBOW, NIPPLE END, SWIVEL FLANGE TO HOSE - 45°

This specification is approved for use by all Departments
 and Agencies of the Department of Defense.

The requirements for acquiring the product described herein
 shall consist of this specification and MIL-DTL-27272.

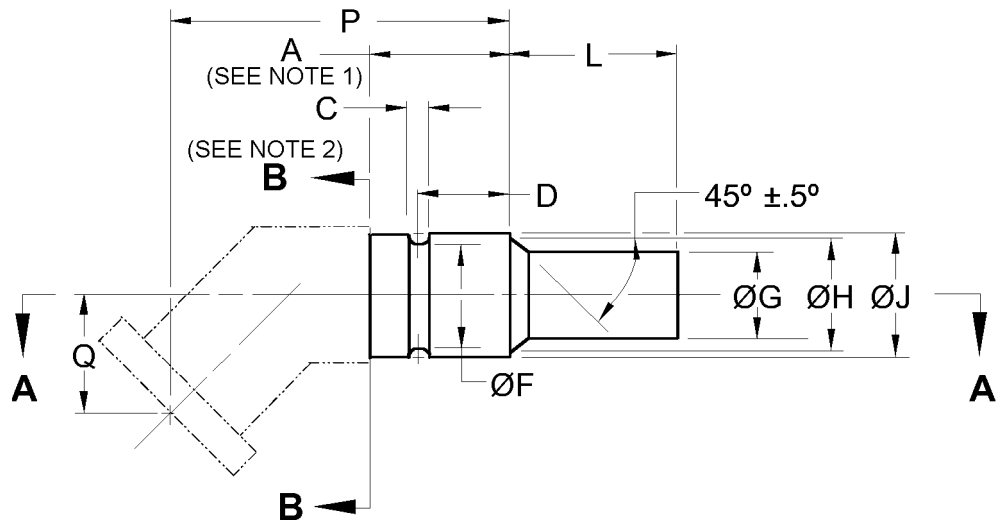
FIGURE 1. Elbow illustration.

MS27084C

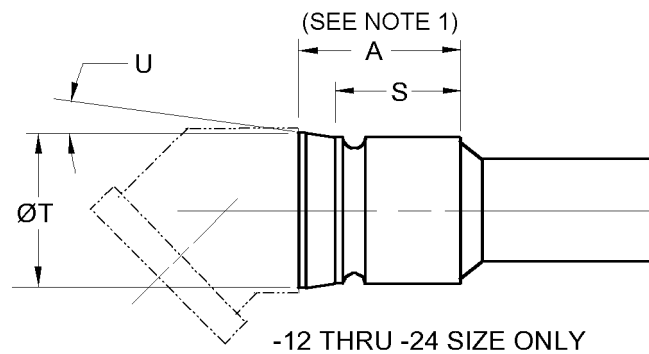
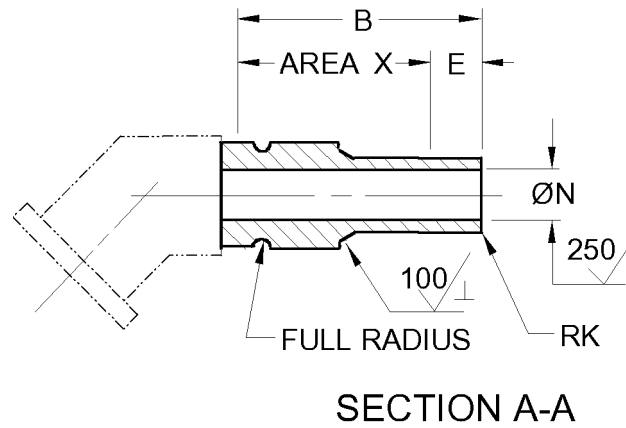

NOTES:

1. Use the A dimension when the adjacent diameter to the left of plane B-B is greater than the J dimension. When the adjacent diameter is equal to or less than the J dimension, the M dimension may be used in place of the A dimension.
2. Any bent tube design of the elbow to the left of plane B-B is acceptable provided the dimensions P and Q and the requirements of this specification sheet and the procurement specification are met. The inside diameter (ID) of the elbow shall not be less than the ID of the nipple end of the elbow. Ovality shall not exceed 7.5 percent of the nominal tubing outside diameter (OD).

FIGURE 1. Elbow illustration – Continued.

MS27084C

REQUIREMENTS

Intended use. This part is a component of elbow subassembly MS27064. This is a design standard for manufacturing purposes. The item is only procured as an integral part of adapter assemblies.

Identification of product. The Part or Identifying Number (PIN) for this part shall be as specified in table I (e.g., MS27084-8C).

Dimensions and tolerances. Dimensions are in inches. Unless otherwise specified, break or radius all corners .005, +.005, -.000. All diameters within length A plus L must be concentric within 0.005 full indicator movement.

Material. PIN suffix C, corrosion-resistant steel, class 321, cold finish condition A, in accordance with SAE AMS-QQ-S-763.

PIN suffix D. Aluminum alloy, 6061-T651 or T6 in accordance with SAE AMS-QQ-A-225/8.

Finish. Corrosion-resistant steel, passivate in accordance with SAE AMS-QQ-P-35. Dry-film lubricate area X with lubricant conforming to SAE AS1701. No overspray allowed.

Aluminum alloy. Anodize in accordance with MIL-A-8625, type II, dye blue.

Remove all burrs and slivers.

Elbow illustration. See figure 1.

Surface roughness. Unless otherwise specified, maximum surface roughness shall not exceed 125 μin . R_a in accordance with ASME B46.1.

Order of precedence. This specification takes precedence over the documents referenced herein. Unless otherwise specified, referenced documents shall be of the issue in effect on the date of solicitation.

MS27084C

TABLE I. Elbow requirements.

PIN MS27084		A ^{1/} min	B min	C		D + .005 - .000		E	
Steel	Alum					Steel	Alum		
-8C	-8D	.617	1.030	.098	+ .004	.385	.385	.32	±.12
-10C	-10D	.654	1.130			.420	.427	.35	±.15
-12C	-12D	.755	1.240	.128	+ .005 - .000	.500	.500		
-16C	-16D	.831	1.340			.545	.545	.39	±.19
-20C	-20D	.881	1.570			.565	.571	.48	±.28
-24C	-24D	1.035	1.720			.665	.665	.50	±.30

PIN MS27084		F		G + .005 - .000	H ± .005	J + .005 - .000	K		L	
Steel	Alum									
-8C	-8D	.497	+ .005 - .000	.426	.530	.616	.020	+ .005 - .000	.600	±.015
-10C	-10D	.586		.526	.625	.706			±.005	
-12C	-12D	.674		.650	.760	.826	.030		.675	±.025
-16C	-16D	1.001	+ .008 - .000	.900	1.040	1.150			.730	
-20C	-20D	1.255	+ .005	1.151	1.275	1.405			.935	
-24C	-24D	1.490	- .000	1.401	1.550	1.635			.980	

PIN MS27084		M ^{1/} min	N		P ±.035	Q ±.035	S ±.010	T max	U max
Steel	Alum		Steel	Alum					
-8C	-8D	.583	.345	.345	+ .006 - .000	1.266	.423	-	-
-10C	-10D	.620	.440	.440		1.324	.375	-	-
-12C	-12D	.720	.560	.560	1.782	.468	.625	.900	15.5°
-16C	-16D	.796	.828	.828	1.838	.505	.670	1.190	1.5°
-20C	-20D	.846	1.058	1.058	2.052	.569	.695	1.485	15.5°
-24C	-24D	1.000	1.253	1.282	+ .005 - .000	2.318	.624	.795	

^{1/} Use the A dimension when the adjacent diameter to the left of plane B-B is greater than the J dimension. When the adjacent diameter is equal to or less than the J dimension, the M dimension may be used in place of the A dimension.

MS27084C

Changes from previous issue. Marginal notations are not used in this revision to identify changes with respect to the previous issue, due to the extent of the changes.

CONCLUDING MATERIAL

Custodians:

Army - AV
Navy - AS
Air Force - 99
DLA - CC

Preparing activity:

DLA - CC

(Project 4730-0868-057)

Review activities:

Army - AR, AT, MI
Navy - MC, SA, SH
Air Force - 71