

FED. SUP CLASS
4730

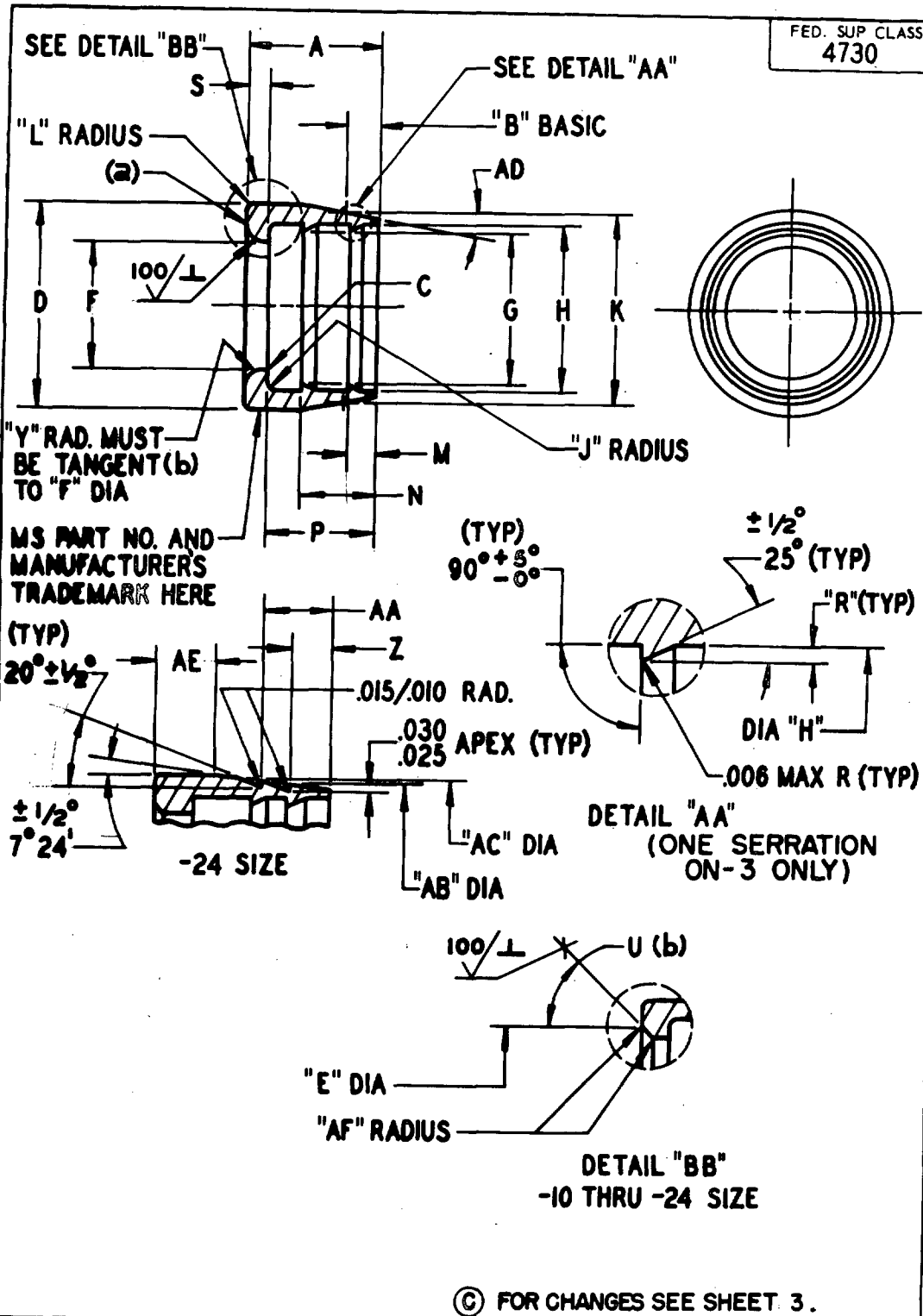

Use Activities:
Army - AI
Navy - SH

Review Activities:
Army - AV
Navy - AS
Air Force - 1182

This military standard is approved by the Department of Defense and is mandatory on all activities. Selection for all engineering and design applications and for repetitive use shall be made from this document.

APPROVED 1 SEP 61 REVISED 2 JUL 63 2 MAY 66 6 MAR 69

NOTE: The Government has a royalty free license under the following listed patents for the benefit of manufacturers of the item either for the Government or for use in equipment to be delivered to the Government. (U. S. Patent Nos. 2,833,567; 3,044,163; 3,055,682)

© FOR CHANGES SEE SHEET 3.

P.A. AIR FORCE-II	TITLE	MILITARY STANDARD
Other Cust ARMY-AV NAVY-AS	SLEEVE, HOSE COUPLING	MS27070
Procurement Sp. No. MIL-F-27212	SUPERSEDES:	SHEET 1 OF 3

FED. SUP CLASS
4730

MS PART NUMBER	A ±.005	B	C	D +.000 -.005	E ±.005	F	G
MS27070-4C		.0850		.375	—	.211	.266 ±.005
MS27070-5C	.285	.0757	.005	.437	—	.274	.329
MS27070-6C		.0815	MAX.	.500	—	.336	.390
MS27070-8C	.355	.0955	BREAK	.625	—	.432	.491
MS27070-10C	.380	.1134		.745	.585	.532	.596 ±.006 -.000
MS27070-12C	.400	.1099	—	.875	.715	.658	.728
MS27070-16C	.500	.1099	—	1.155	.985	.908	.978
MS27070-20C	.740	.1381	—	1.470	1.225	1.160	1.233
MS27070-24C	.760	—	—	1.740	1.490	1.410	1.520
MS27070-30C	.230	.0590	.005 MAX BREAK	.294 +.005 -.005	—	.141	.201 ±.005 -.000

H	J MAX	K ±.003	L	M ±.005	N ±.005	P ±.005	R
.280		.344	—	—	—	—	—
.344		.408	—	.060	.160	—	.012
.415	.015	.468	—	—	—	—	—
.495		.589	—	—	—	—	—
.631		.703	—	.100	.225	—	.016 ±.002
.745		.834	—	—	—	—	—
.913		1.084	.005	+.015 -.005	—	.370	—
1.205		1.359	—	—	—	—	—
1.555	.002	—	.010	.190	.340	.590	—
.225	.005	.018	—	—	.090	—	.012

S	U ±1/2°	Y +.005 -.000	Z ±.005	AA ±.005	AB ±.005	AC ±.005	AD ±1/4°	AE ±.005	AF +.005 -.005
.050		—	—	—	—	—	—	—	—
.055		—	.040	—	—	—	—	—	—
.080		—	—	—	—	—	10°	—	—
.100	±.005	—	—	—	—	—	—	—	—
—		45°	—	—	—	—	—	—	.005
—		—	—	—	—	—	—	—	—
—		—	.174	.298	1.658	1.690	—	.260	—
.030	+.005 -.000	—	.035	—	—	—	10°	—	—

P.A. AIR FORCE-11	TITLE	MILITARY STANDARD
Other Cust ARMY-AV NAVY-AS	SLEEVE, HOSE COUPLING	MS27070
Procurement Specification MIL-F-27272	SUPERSEDES:	SHEET 2 OF

APPROVED I SEP 61 REVISED 61 FOR CHANGES SEE SHEET 3.

NOTE: The Government has a royalty free license under the following listed patents for the use benefit of manufacturers of the item either for the Government or for use in equipment to be delivered to the Government. (U. S. Patent Nos. 2,833,567; 3,044,163; 3,055,682)

Review activities: - AV - AS - AS - AS
 User activities: ARMY - AV - AS - AS
 AIR FORCE - 11, 92
 This military standard is approved by the Department of Defense and is mandatory on all activities. Extension for all engineering and design applications and for repetitive use shall be made from this document.

FED. SUP CLASS
4730

(a) HARDNESS TO BE TESTED ON SURFACE SHOWN.

(b) MUST BE FREE FROM LONGITUDINAL SCRATCHES, NICKS OR TOOL MARKS.

(c) MS27070-3C IS INACTIVE FOR DESIGN AFTER 2 MAY 1966. USE ONLY FOR REPLACEMENT OF IDENTICAL ITEMS IN EXISTING MILITARY EQUIPMENT. USE MS27070-4C FOR DESIGN.

MATERIAL: CORROSION RESISTING STEEL, (17-4PH) PER SPECIFICATION AMS5843.

HEAT TREAT TO CONDITION H-1150; HARDNESS SHALL BE ROCKWELL "C"-31 TO "C"-35.

FINISH: PASSIVATE PER PROCUREMENT SPECIFICATION.

DRY-FILM LUBRICATE RADIUS "Y" AND ANGLE "U" IN ACCORDANCE WITH MIL-L-8937. DRY-FILM ON "D" DIA AND "Y" DIA SHALL NOT BE CAUSE FOR REJECTION. DO NOT DRY-FILM TAPER "AD". DO NOT DRY-FILM -4, -5 & -6 SIZES NOR BEYOND "AE" DIMENSION ON -24 SIZE.

DIMENSIONS IN INCHES. UNLESS OTHERWISE SPECIFIED: RADIUS OR BREAK ALL CORNERS .005, +.005/-0.00. REMOVE ALL BURRS AND SLIVERS. SURFACE ROUGHNESS PER ASA B46.1-1962 NOT TO EXCEED 125 RHR. ALL DIAMETERS MUST BE CONCENTRIC WITHIN .005 TIR.

THIS PART FOR USE WITH MIL-H-27267 NOSE.

THIS STANDARD TAKES PRECEDENCE OVER DOCUMENTS REFERENCED HEREIN.

REFERENCED DOCUMENTS SHALL BE OF THE ISSUE IN EFFECT ON DATE OF INVITATIONS FOR BID.

NEXT ASSEMBLY MS27063 THRU MS27060.

P.A. AIR FORCE-11	TITLE	MILITARY STANDARD
Other Cust ARMY-AV NAVY-AS	SLEEVE, HOSE COUPLING	MS27070
Procurement Specification MIL-F-27272	SUPERSEDES:	SHEET 3 OF

DD FORM 672 (Coordinated) PREVIOUS EDITIONS OF THIS FORM ARE OBSOLETE.

User Activities:
Army - MI
Navy - SPReview Activities:
Army - AV
Navy - AS
Air Force - 1,82

This military standard is approved by the Department of Defense and is mandatory on all activities. Selection for all new engineering and design applications and for repetitive use shall be made from this document.

APPROVED 1 SEP 61 REVISED FOR CHANGES SEE SHEET 3.
NOTE: The Government has a royalty free license under the following listed patents for the benefit of manufacturers of the item either for the Government or for use in equipment to be delivered to the Government. (U. S. Patent Nos. 2,833,567; 3,044,163; 3,055,682)