

INCH-POUND

MS27057E
 7 October 2013
 SUPERSEDING
 MS27057D
 24 September 2003

DETAIL SPECIFICATION SHEET

ADAPTER ASSEMBLY, FLARED, 90° ELBOW,
 TUBE TO HOSE - WITH SWIVEL NUT

This specification sheet is approved for use by all Departments
 and Agencies of the Department of Defense.

The requirements for acquiring the product described herein
 shall consist of this specification sheet and MIL-DTL-27272.

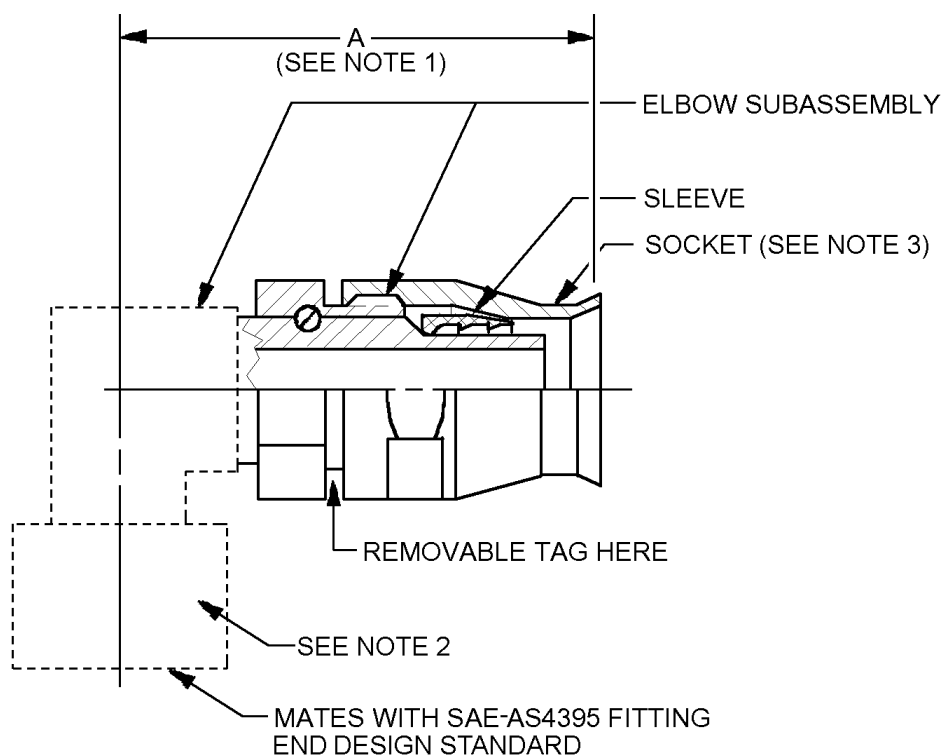

NOTES:

1. Dimension A, see table II, is measured between the hose end of the socket and the free end of the insert at its centerline when the socket is assembled on the elbow subassembly.
2. If required, lockwire holes to be drilled in accordance with SAE-AS1043.
3. Socket may be hex or 2-flat sides.

FIGURE 1. Adapter assembly illustration.

MS27057E

REQUIREMENTS:

Adapter assembly illustration. See figure 1.

Intended use. This adapter is intended for use with hose conforming to MIL-DTL-27267.

Materials. Material and material codes see table I. See applicable specification sheet and MIL-DTL-27272 for material of other components identified in table II for their material requirements.

TABLE I. Materials and material codes.

Material code	Material
Blank	Combination of aluminum alloy and corrosion-resistant steel (CRES)
C	CRES

TABLE II. Adapter assembly composition. 1/ 2/

Size and material code	Elbow subassembly size and material code	Sleeve size and material code	Socket size and material code	A max 4/ inch (mm)
MS27057	MS27065 3/	MS27070 3/	MS27069 3/	
-10C	-10C	-10C	-10C	2.26 (57.4)
-10	-10			
-12C	-12C	-12C	-12C	2.76 (70.1)
-12	-12			
-16C	-16C	-16C	-16C	2.93 (74.4)
-16	-16			
-20C	-20C	-20C	-20C	3.45 (87.6)
-20	-20			
-24C	-24C	-24C	-24C	3.74 (95.0)
-24	-24			

1/ Dimensions are in inches.

2/ Metric equivalents are given for general information only.

3/ MS27065, MS27069 and MS27070 shall be dry film lubricated in accordance with table III, dry film is applied in accordance with MS27065, MS27069 or MS27070 as applicable.

4/ See figure 1.

If required, lockwire holes to be drilled in accordance with SAE-AS1043 and suffix L added to the Part or Identifying Number (PIN).

MS27065, MS27069 and MS27070 parts shall be coated with the same type of dry film lubricant as indicated in the PIN, no mixing of dry film lubricants shall be used on an assembly unless it is of the types specified by the "blank" designator.

NOTE: Avoid using graphite dry film lubes with aluminum unions and nipples because in a wet environment, graphite becomes corrosive to the aluminum.

MS27057E

TABLE III. Dry film designator.

Dry film designator	SAE class or type designator	Dry film characteristics
Blank	Any SAE class or type below	N/A
SAE-AS1701	SAE-AS1701 class	SAE-AS1701 temperature ranges °F (°C)
4	4	-65° to +1400°F (-54° to 760°C)
5	5	-65° to +850°F (-54° to 454°C)
6	6	-375° to +850°F (-226° to 454°C)
SAE-AS5272	SAE-AS5272 type	SAE-AS5272 temperature ranges. °F (°C)
7	Type I	-90° to 400°F (-68 to 204°C) endurance life of 250 min minimum
8	Type II	-90° to 400°F (-68° to 204°C) endurance life of 450 min minimum
9	Type III	Color 1 - Natural product color -90° to 400°F (-68 to 204°C) low volatile organic compound with an endurance life of 450 min minimum
10	Type III	Color 2 - Black color -90° to 400°F (-68 to 204°C) low Volatile organic compound with an endurance life of 450 min minimum
Dry film designator	MIL classification	Dry film characteristics
MIL-PRF-46010 1/	---	MIL-PRF-46010 temperature ranges. °F (°C)
11	N/A	Color 1 natural product color, -90° to 400°F (-68 to 204°C) solvent resisting
12	N/A	Color 2 - Black color -90° to 400°F (-68 to 204°C) solvent resisting

1/ Not for aerospace usage.

MS27057E

PIN: The PIN consists of prefix "MS", the specification sheet number, dash, number for 90° adapter assembly size, letter for material, blank or L for lockwire holes, and a blank or number for dry film lubricant. Unassigned PIN's shall not be used.

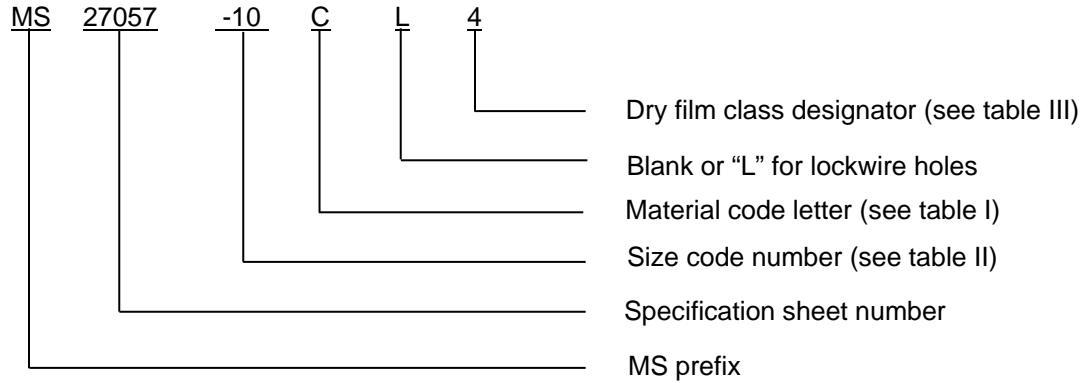

PIN examples:

MS27057-10C	indicates a 90° adapter assembly size 10, CRES with dry film class designator "blank".
MS27057-10C4	indicates a 90° adapter assembly size 10, CRES with dry film class designator 4.
MS27057-10L	indicates a 90° adapter assembly size 10, a combination of aluminum and CRES, with lockwire holes, and with dry film class designator "blank".

Identification of product. The PIN and Government Entity (CAGE) Code or manufacturer's trademark shall be marked on a removable tag securely attached to the adapter.

Order of precedence. Unless otherwise noted herein or in the contract, in the event of a conflict between the text of this document and the references cited herein, the text of this document takes precedence. Nothing in this document, however, supersedes applicable laws and regulations unless a specific exemption has been obtained.

Referenced documents shall be of the issue in effect on date of invitations for bid.

Changes from previous issue. Marginal notations are not used in this revision to identify changes with respect to the previous issue, due to the extent of the changes.

Referenced documents. In addition to MIL-DTL-27272, this document references the following:

MIL-DTL-27267	SAE-AS1043
MIL-PRF-46010	SAE-AS1701
MS27065	SAE-AS4395
MS27069	SAE-AS5272
MS27070	

MS27057E

CONCLUDING MATERIAL

Custodians:

Army - AV
Navy - AS
Air Force - 99
DLA - CC

Preparing activity:

DLA - CC

(Project 4730-2013-097)

Review activities:

Army - AR, AT, MI
Navy - MC, SA, SH
Air Force - 71

NOTE: The activities listed above were interested in this document as of the date of this document. Since organizations and responsibilities can change, you should verify the currency of the information above using the ASSIST Online database at <https://assist.dla.mil>.