

PRD. SUP CLASS.
5220

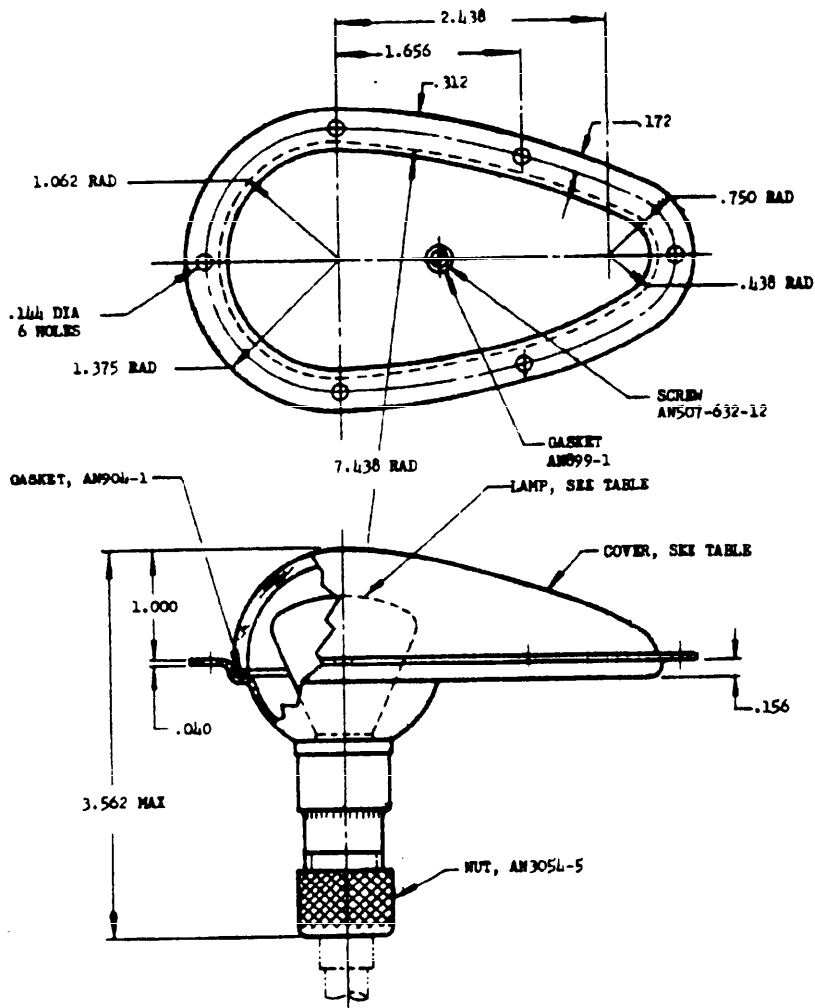

ASSEMBLY DASH NO.			LAMP		COVER			REMARKS
WITH LAMP AND COVER	FLIN	WITHOUT LAMP AND COVER	FLIN	PART NO.	VOLTAGE	PART NO.	COLOR	
-1		-3		MS25235-311	20	MS25216-1	AVIATION WHITE (CLEAR)	WITHOUT SHIELD
-2						MS25216-2		WITH SHIELD

PART NUMBERS MS25215-1, -2, AND -3 REPLACE AND ARE INTERCHANGEABLE WITH PART NUMBERS AN3097-14, -15, AND -3, RESPECTIVELY.

DIMENSIONS IN INCHES. DIMENSIONS ARE FOR REFERENCE ONLY.

WEIGHT: .35 LB MAX.

THIS STANDARD TAKES PRECEDENCE OVER DOCUMENTS REFERENCED HEREIN.

REFERENCED DOCUMENTS SHALL BE OF THE ISSUE IN EFFECT ON DATE OF INVITATIONS FOR BID.

THIS DOCUMENT HAS BEEN PROMULGATED BY THE DEPARTMENT OF DEFENSE AS THE MILITARY STANDARD TO LIMIT THE SELECTION OF THE ITEM, PRODUCT, OR DESIGN COVERED HEREIN IN ENGINEERING, DESIGN, AND PROCUREMENT. THIS STANDARD SHALL BECOME EFFECTIVE NOT LATER THAN 90 DAYS AFTER THE LATEST DATE OF APPROVAL SHOWN.

CUSTODIANS Navy - BuAer Air Force	OTHER INT. A - N - AF -	MILITARY STANDARD		MS25215 (ASG)
		LIGHT ASSEMBLY, UPWARD RECOGNITION		
PROCUREMENT SPECIFICATION MIL-L-6723		SUPERSEDES: AN3097		SHEET 1 OF 1

APPROVED 15 AUG 57 REVISED

NOTES: When Government drawings, specifications, or other data are used for any purpose other than in connection with a definitely related Government procurement operation, the United States Government thereby incurs no responsibility, nor any obligation whatsoever; and the fact that the Government may have furnished, furnished, or in any way supplied the said drawings, specifications, or other data is not to be regarded by implication or otherwise as in any manner licensing the holder or any other person or corporation, or conveying any rights or permission to manufacture, use, or sell any patented invention that may in any way be related thereto.