

FED. SUP CLASS.
5355 (E)

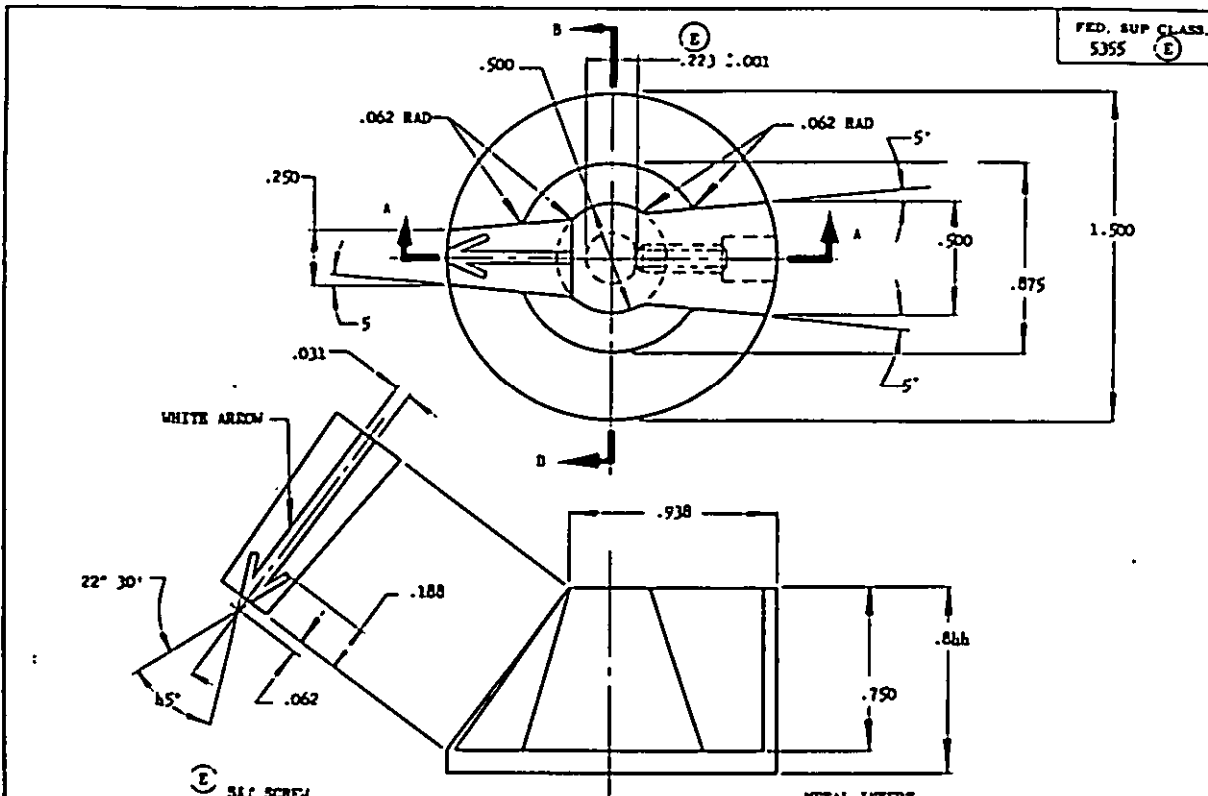

WHITE ARROW

(E) SET SCREW
AN565 DCB-7

DRILL .136, AMD10387
THREAD NO. 8-32 NC-2B
SPECIFICATION MIL-S-7742
COUNTERDRILL .173
DEPTH .250

METAL INSERT

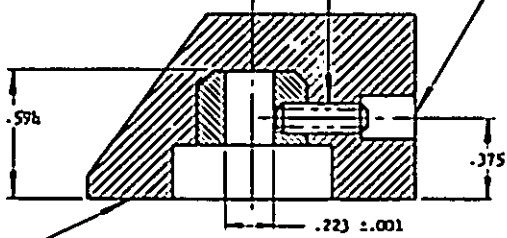

PERMANENTLY MARK NS PART NUMBER AND
MANUFACTURER'S NAME OR TRADE-MARK

SECTION A-A

DASH NO.	
-1	

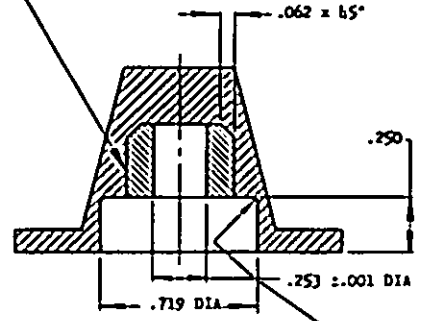

SECTION B-B

.087 MAX 65 CHAMFER OR .076 MAX
RADIUS FILLET RADIUS

- (B) MATERIAL: TRANSPARENT PLASTIC.
INSERT, BRASS QC-B-611, COMP B, 1/2 HARD SETSCREW, CRES, MIL-S-7720, COMP 303S OR 303SZ.
 - (E) FINISH: THE ENTIRE OUTER SURFACE OF KNOB, EXCEPT FOR THE WHITE ARROW, SHALL BE COATED WITH A GRAY MAT MATERIAL HAVING A DARK GULL GRAY COLOR CONFORMING TO COLOR NUMBER 36231 IN ACCORDANCE WITH FED STANDARD No. 595.
INSERT, LOCK SETSCREW, PASSIVATE.
CONTRAST OF THE WHITE ARROW AND GRAY COATING SHALL BE NOT LESS THAN 2.5 WHEN DETERMINED AS SPECIFIED IN SPECIFICATION MIL-P-7788.
BREAK ALL SHARP EDGES AND CORNERS.
DIMENSIONS IN INCHES. UNLESS OTHERWISE SPECIFIED, TOLERANCES: DECIMALS ±.016, ANGLES ±2° 0'.
- THIS STANDARD TAKES PRECEDENCE OVER DOCUMENTS REFERENCED HEREIN.
REFERENCED DOCUMENTS SHALL BE OF THE ISSUE IN EFFECT ON DATE OF INVITATIONS FOR BID.

Approved for Release by NSA on 05-08-2014 pursuant to E.O. 13526
 User's Manual Army - 20
 Buy from: DISC USAF - ASD 11, Navy - 46ps
 This military standard is approved by the Department of Defense and is mandatory on all activities. Selection for all new engineering and design applications and for replacements shall be made from this document.

APPROVED 6 Jul 55 REVISED 10 Oct 55 (A) 22 Jan 57 (C) 26 May 58 (D) 10 Sep 58 (E) 26 Nov 64

P.A. NAVY - 47 Other Cost Army - 5C USAF - 11	TITLE KNOB, POINTER, ILLUMINATED	MILITARY STANDARD
		MS25166 (E)
PROCUREMENT SPECIFICATION MIL-K-25069 (E)	SUPERSEDES: NS 25166(ASO) (E)	SHEET 1 OF 1