

INCH-POUND

MS25082P  
w/AMENDMENT 2  
5 January 2011  
SUPERSEDING  
MS25082P  
w/AMENDMENT 1  
10 September 2004

DETAIL SPECIFICATION SHEET

NUT, PLAIN, HEXAGON  
ELECTRICAL - THIN

Reactivated after 5 January 2011 and may be used for new and existing designs and acquisitions.

This specification is approved for use by all departments and agencies of the Department of Defense.

The requirements for acquiring the product described herein shall consist of this specification sheet and FF-N-836.

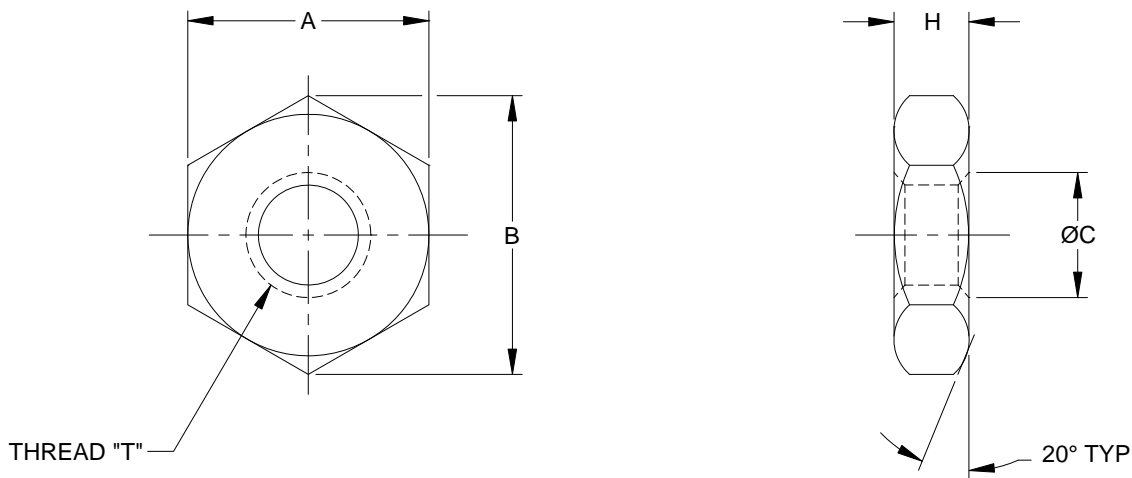

Figure 1. Dimensions and configurations.

MS25082P  
w/Amendment 2Table 1. Dimensions.

DASH NUMBERS				"T" THREAD	A		B		ØC MAX	H ±.005
STEEL CAD PLATED	CRES	BRASS OXIDE COATED	BRASS SILVER PLATED		MAX	MIN	MAX	MIN		
1	C1	B1	S1	.1380-32 UNC-2B	.312	.302	.361	.344	.168	.078
2	C2	B2	S2	.1640-32 UNC-2B	.344	.332	.397	.378	.194	.078
3	C3	B3	S3	.1900-32 UNF-2B	.375	.362	.433	.413	.220	.078
12	C12	B12	S12	.1900-32 UNF-2B	.250	.241	.289	.275	.220	.078
4	C4	B4	S4	.2500-28 UNF-2B	.438	.428	.505	.488	.280	.089
13	C13	B13	S13	.2500-32 UNEF-2B	.312	.302	.361	.344	.280	.078
26	C26	B26	S26	.2500-36 UNS-2B	.312	.302	.361	.344	.280	.063
14	C14	B14	S14	.2500-40 UNS-2B	.312	.302	.361	.344	.280	.063
5	C5	B5	S5	.3125-24 UNF-2B	.562	.545	.650	.621	.342	.104
23	C23	B23	S23	.3125-32 UNEF-2B	.444	.423	.505	.482	.342	.093
24	C24	B24	S24	.3125-32 UNEF-2B	.562	.545	.650	.621	.342	.078
6	C6	B6	S6	.3750-24 UNF-2B	.625	.607	.722	.692	.405	.104
7	C7	B7	S7	.3750-32 UNEF-2B	.562	.545	.650	.621	.405	.078
20	C20	B20	S20	.3750-32 UNEF-2B	.562	.545	.650	.621	.405	.093
18	C18	B18	S18	.4375-32 UN-2B	.500	.489	.577	.557	.472	.093
25	C25	B25	S25	.4375-32 UN-2B	.562	.545	.650	.621	.472	.093
8	C8	B8	S8	.4688-32 UNS-2B	.562	.545	.650	.621	.510	.078
21	C21	B21	S21	.4688-32 UNS-2B	.562	.545	.650	.621	.510	.093
19	C19	B19	S19	.5000-28 UNEF-2B	.625	.609	.722	.692	.540	.109
15	C15	B15	S15	.5000-32 UN-2B	.562	.545	.650	.621	.540	.078
22	C22	B22	S22	.5000-32 UN-2B	.562	.545	.650	.621	.540	.093
10	C10	B10	S10	.6250-18 UNF-2B	.812	.788	.938	.895	.675	.139
11	C11	B11	S11	.6250-24 UNEF-2B	.750	.736	.866	.840	.675	.104
16	C16	B16	S16	.6875-27 UNS-2B	.812	.788	.938	.895	.730	.093
17	C17	B17	S17	1.0000-27 UNS-2B	1.125	1.088	1.299	1.240	1.060	.093

Figure 1. Dimensions and configurations. - Continued

## NOTES

1. A and B dimensional ranges have been revised on some of the dash numbers to conform with ASME B18.2.2 and ASME B18.6.3.
2. For brass nuts manufactured from milled bar only, the tabulated maximum width across flats dimensions may be exceeded to conform with the commercial tolerances of drawn or rolled bar stock material. The nominal bar size used shall be the closest commercially available size to the specified basic width across the flats, and across corners of the nut.
3. Part numbers MS25082-9 and MS25082-B9 were cancelled after 8 October 1968 and replaced by MS25082-11 and MS25082-B11 respectively.
4. In the event of a conflict between the text of this document and the references cited herein, the text of this document shall take precedence.
5. Unless otherwise specified referenced documents are those in effect at the time of solicitation.

MS25082P  
w/Amendment 2

REQUIREMENTS:

1. Materials:

Steel compositions in accordance with SAE-AIR 4127, 55 ksi minimum tensile strength (sulfur or phosphorus shall not exceed .050 by weight for nuts heat treated to Rockwell hardness C36 or greater).

Brass composition 360 with H02 temper (UNS C36000) in accordance with ASTM-B16/B16M.

CRES (stainless steel) composition 303 (UNS S30300) in accordance with ASTM-A581/A581M or ASTM-A582/A582M.

2. Finish/Plating:

Steel nuts shall be cadmium plated in accordance with SAE-AMS-QQ-P-416, Type II, Class 2.

Brass nuts shall be silver plated in accordance with ASTM B700.

CRES nuts shall be passivated in accordance with SAE-AMS2700.

3. Threads shall be in accordance with FED-STD-H28/2. Thread acceptability shall be in accordance with FED-STD-H28/20, System 21.

4. Break all sharp edges and remove all burrs. The chamfer or countersink at both edges of tapped hole shall not be greater than .005 inch.

5. Dimensions are in inches. Unless otherwise specified, tolerance for angles shall be  $\pm 5^\circ$ .

6. Bearing surface: The diameter of the circle of the bearing surface shall be the maximum across flats dimension within a tolerance of minus three percent. The bearing surface shall be perpendicular to the thread axis within  $2^\circ$  for nuts .625 inch and smaller and  $1^\circ$  for nuts larger than .625 inch.

7. Part number: The part number shall consist of the basic MS number followed by a dash number from table 1.

Example: MS25082 - 1

Dash number  
Basic number

MS25082-1 indicates Steel, cadmium plated, .138 inch nominal threaded, Class 2B, plain hexagon nut.

8. Changes from previous issue. The margins of this specification are marked with vertical lines to indicate where changes from the previous issue were made. This was done as a convenience only and the Government assumes no liability whatsoever for any inaccuracies in these notations. Bidders and contractors are cautioned to evaluate the requirements of this document based on the entire content irrespective of the marginal notations and relationship to the last previous issue.

MS25082P  
w/Amendment 2

Custodians:  
Army - AR  
Navy - AS  
Air Force - 99

Preparing Activity:  
DLA - IS

(Project 5310-2011-001)

Reviewer activities:

Army - AV, CR  
Navy - EC, MC  
Air Force - 71

NOTE: The activities listed above were interested in this document as of the date of this document. Since organizations and responsibilities can change, you should verify the currency of the information above using the ASSIST Online database at <https://assist.daps.dla.mil>.