

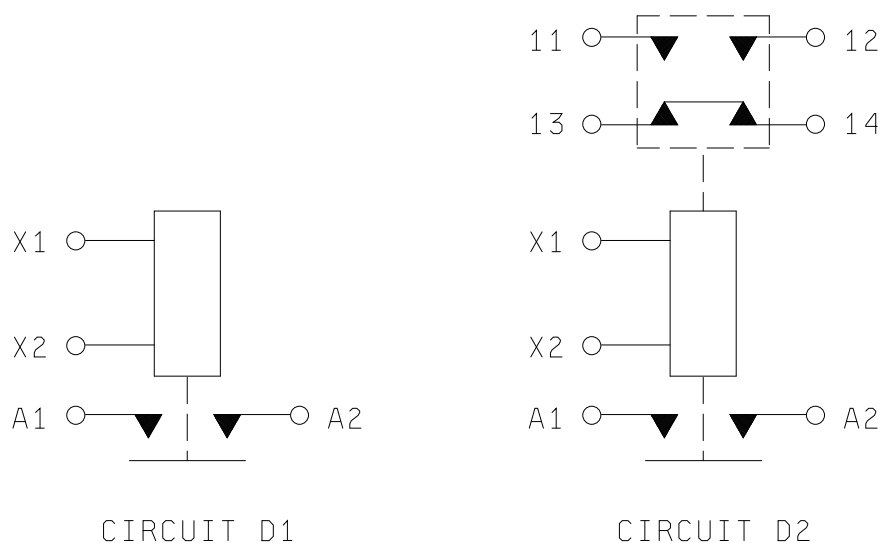

## MS24142P



Inches	mm	Inches	mm	Inches	mm
.010	0.25	.328	8.33	1.844	46.84
.031	0.79	.375	9.53	1.875	47.63
.063	1.60	.453	11.51	2.063	52.40
.095	2.41	.625	15.88	2.847	72.31
.138	3.51	.750	19.05	3.000	76.20
.240	6.10	.688	17.48	3.347	85.01
.250	6.35	.969	24.61	3.672	93.27
.266	6.76	1.172	29.77	3.732	94.79
.312	7.92	1.438	36.53	4.692	119.18

## NOTES:

1. Dimensions are in inches.
2. Metric equivalents are given for general information only.
3. Unless otherwise specified, tolerance is  $\pm .031$ .
4. This specification sheet takes precedence over documents referenced herein.
5. Referenced Government documents of the issue listed in Assist Online (<https://assist.dla.mil>) or Assist Quick Search (<https://quicksearch.dla.mil>) specified in the solicitation form a part of this specification to the extent specified herein.
6. Coil and auxiliary terminals may use additional flat washer for terminal seat.
7. Cadmium or cadmium compounds are prohibited on external hardware.
8. Spring washer on drawing is a spring lock washer.

FIGURE 1. Dimensions and configurations - Continued.

## MS24142P

## REQUIREMENTS:

Dimensions and configurations: See [figure 1](#).

Environmental characteristics:

Temperature range: -70° to +125°C.

Maximum altitude rating: 80,000 ft.

Shock G-level: 25 g's.

Duration: 6-9 ms.

Max duration contact opening: 2 ms.

Vibration - sinusoidal: See [table I](#).

Vibration - random: Not applicable.

High shock: Not applicable.

Acceleration: 15 g's.

Electrical characteristics (see [tables II, III, and IV](#)):

Insulation resistance, initial: 100 megohms.

After life or environmental tests: 50 megohms.

Dielectric strength (sea level): 2-5 seconds.

	Initial		After life tests	
	28 V dc	115 V ac	28 V dc	115 V ac
Coil to case	1,250 V rms	1,500	1,000 V rms	1,125
Aux contacts	1,250 V rms	1,500	1,000 V rms	1,125
All other points	1,250 V rms	1,500	1,000 V rms	1,125

Dielectric strength (altitude): 1 minute.

	28 V dc	115 V ac
Coil to case	500 V rms	500
Aux contacts	500 V rms	500
All other points	500 V rms	500

Max contact drop initial: .150 volt.

After life test: .175 volt.

Overload current (NO): 1,600 amperes.

Rupture current (NO): 2,000 amperes.

Duty rating: Continuous.

RFI specification: [MIL-STD-461](#).

(Applicable to coil circuits of ac operated relays).

## MS24142P

TABLE I. Vibration levels.

Dash number	5-10 Hz	10-55 Hz	55-250 Hz	250-500 Hz	500-1,500 Hz
D1	.08 DA	.06 DA	10 g's	5 g's	4 g's
D2				3 g's	3 g's

TABLE II. Operating characteristics.

PIN MS 24142-	Coil data										Time - milliseconds max <u>2/</u>						
	Coil	Rated			Max		Max pick-up voltage			Hold voltage <u>2/</u>	Drop out voltage <u>2/</u>	Oper-ate <u>3/</u>	Re-lease <u>4/</u>	Bounce <u>4/</u>			
		Volts <u>1/</u>	Freq Hz	$\Omega$ Res +15% -10	Volts	Amp	Normal <u>2/</u>	High temp test	Cont current test					Main		Aux	
														NO	NC	NO	NC
D1	X1,X2	28	dc	52	29	0.6	18	21	22.5	7.0	1.5	40	15	2	---	---	---
D2	X1,X2	28	dc	52	29	0.6	18	21	22.5	7.0	1.5	40	15	2	---	4	4

1/ CAUTION: Use of any coil voltage less than rated coil voltage will compromise the operation of the relay.

2/ Over the temperature range.

3/ With rated coil voltage.

4/ From rated coil voltage.

TABLE III. Rated contact load (amperes per pole) case grounded.

Type of load	Life operating cycles x 10 <sup>3</sup>	28 V dc				115 V ac, 1 phase				115/200 V ac, 3 phase <u>1/</u>			
		Main		Aux		Main		Aux		Main		Aux	
		NO	NC	NO	NC	400 Hz	60 Hz	400 Hz	60 Hz	400 Hz	60 Hz	400 Hz	60 Hz
Resistive	50	200		5	5	200		5					
Inductive	10	100		5	5								
Motor	50	100				150							
Lamp <u>2/</u>	50			.75	.75			.75					
Transfer load <u>3/</u>													
Mechanical life reduced current	100	50		1.25	1.25	50		1.25					
Mixed loads	50	20		Applicable per spec		20							

1/ Absence of value indicates relay is not rated for 3-phase application.

2/ The total "On" time shall be 2 seconds  $\pm$ 0.05 second and the "Off" time shall be 7 seconds  $\pm$ 2.0 seconds for a simulated lamp load.

3/ Transfer load indicates relay is suitable for transfer between unsynchronized ac power supplies at rating indicated.

Part or Identifying Number (PIN): MS24142 (plus dash number from [table IV](#)).

General characteristics: See [table IV](#).

## MS24142P

TABLE IV. Dash numbers and general characteristics. <sup>1/</sup>

Part number MS24142-	Type	Coil type	Terminal type	Mounting or mating socket	Auxiliary contacts	Maximum weight in pounds <sup>2/</sup>
D1	I	dc	Stud	Flange	None	2.3
D2		dc			Yes	2.5

<sup>1/</sup> A1 and A2 have been canceled without replacement.

<sup>2/</sup> Weights include covers and barriers.

If the relays produced for MS24142 are similar in construction and design except for the power rating to the relays produced for [MS24140](#) and [MS24141](#), then reduced testing for qualification of MS24142 relays may be performed concurrent with or subsequent to successful qualification of [MS24140](#) or [MS24141](#).

Qualification by similarity: See [MIL-PRF-6106](#).

The margins of this specification are marked with vertical lines to indicate where changes from the previous issue were made. This was done as a convenience only and the Government assumes no liability whatsoever for any inaccuracies in these notations. Bidders and contractors are cautioned to evaluate the requirements of this document based on the entire content irrespective of the marginal notations and relationship to the previous issue.

Referenced documents. In addition to [MIL-PRF-6106](#), this document references the following:

[MS24140](#) [MS24141](#) [MIL-STD-461](#) [MS27243](#)

Custodians:

Navy - AS  
Air Force - 85  
DLA - CC

Preparing activity:  
DLA - CC

(Project 5945-2019-004)

Review activities:

Navy - EC

NOTE: The activities listed above were interested in this document as of the date of this document. Since organizations and responsibilities can change, you should verify the currency of the information above using the ASSIST Online database at <https://assist.dla.mil/>.