

FED. SUP CLASS
1670

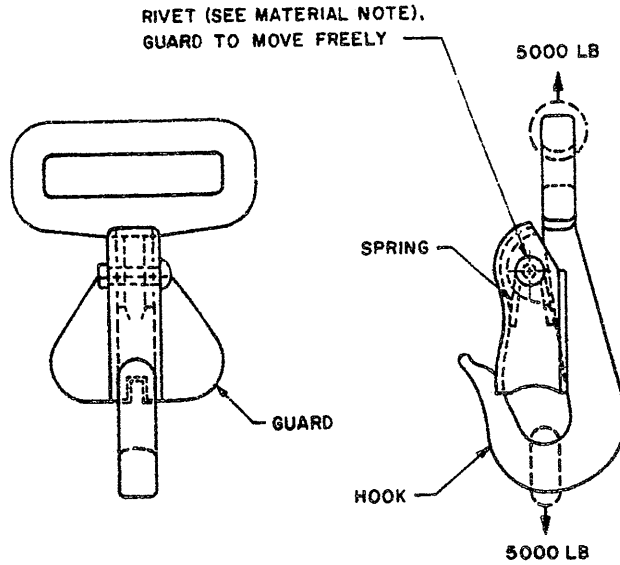

ASSEMBLY

| DASH NO |
|---------|
| -1 |
| -2 |

NOTES:

MATERIAL: HOOK, STEEL, MIL-S-6826 OR MIL-S-6049.
 GUARD, STEEL, MIL-S-7952 OR QQ-S-698.
 SPRING, STEEL, QQ-W-470.
 RIVET, CRES, FF-R-556, TYPE XII, CLASS 3, GRADE C, DIAMETER AND LENGTH TO SUIT.

METHOD OF FORMING: HOOK - HOT FORGE

HEAT TREATMENT: HOOK - 170,000 TO 190,000 LBS/SQ IN. TENSILE STRENGTH IN ACCORDANCE WITH MIL-H-6875.
 GUARD - NONE.
 SPRING - AS REQUIRED BY FINISH SPECIFICATION.

SURFACE ROUGHNESS SHALL BE $125\sqrt{}$ MAX. IN ACCORDANCE WITH ANSI B46.1

FINISH: HOOK, SPRING AND GUARD BEFORE ASSEMBLY
 -1, CADMIUM PLATE, QQ-P-416, CLASS 1, TYPE 1.
 -2, PHOSPHATE COAT, MIL-C-16292, TYPE Z, CLASS 4B FOLLOWED BY WAX EMULSION
 MIL-W-3698 (OPTIONAL FINISH FOR SPRING - 1 AS ABOVE).

DIMENSIONS IN INCHES. EXCEPT AS OTHERWISE SPECIFIED HEREIN, TOLERANCES: DECIMALS $\pm .03$, ANGLES $\pm 2^\circ$. WIRE AND METAL GAGES EXCLUDED.

PROOF LOAD: SNAP HOOK SHALL BE SUBJECTED TO THE PROOF LOAD SPECIFIED, AS INDICATED BY ARROWS.

ALL PERPENDICULAR SURFACES SHALL INTERSECT WITH A .04-.11 RADIUS UNLESS OTHERWISE SPECIFIED.

SNAP HOOK ASSEMBLY SHALL PASS FREELY OVER A .281 DIA. ROD.

FOR DESIGN FEATURE PURPOSES, THIS STANDARD TAKES PRECEDENCE OVER PROCUREMENT DOCUMENTS REFERENCED HEREIN.

REFERENCED DOCUMENTS SHALL BE OF THE ISSUE IN EFFECT ON DATE OF INVITATIONS FOR BID.

(A) ENTIRE STANDARD REVISED.

Inter activities:
NAVY-MC
ARMY-AV

Review activities:
AIR FORCE -II

This military standard is approved for use by all departments and agencies of the Department of Defense. Selection for all new engineering and design applications and for repetitive use shall be made from this document.

APPROVED 12 MAY 61 REVISED (A) 11 APR 75

| | | | |
|--|--|-------------------|------|
| P.A. AIR FORCE -82 Other Cust NAVY-AS ARMY-GL | TITLE SNAP HOOK-QUICK CONNECTOR, PARACHUTE HARNESS | MILITARY STANDARD | |
| | | MS22042 | |
| PROCUREMENT SPECIFICATION MIL-H-7195 | SUPERSEDES: AN6507 | SHEET | OF 3 |

FED. SUP CLASS
1670

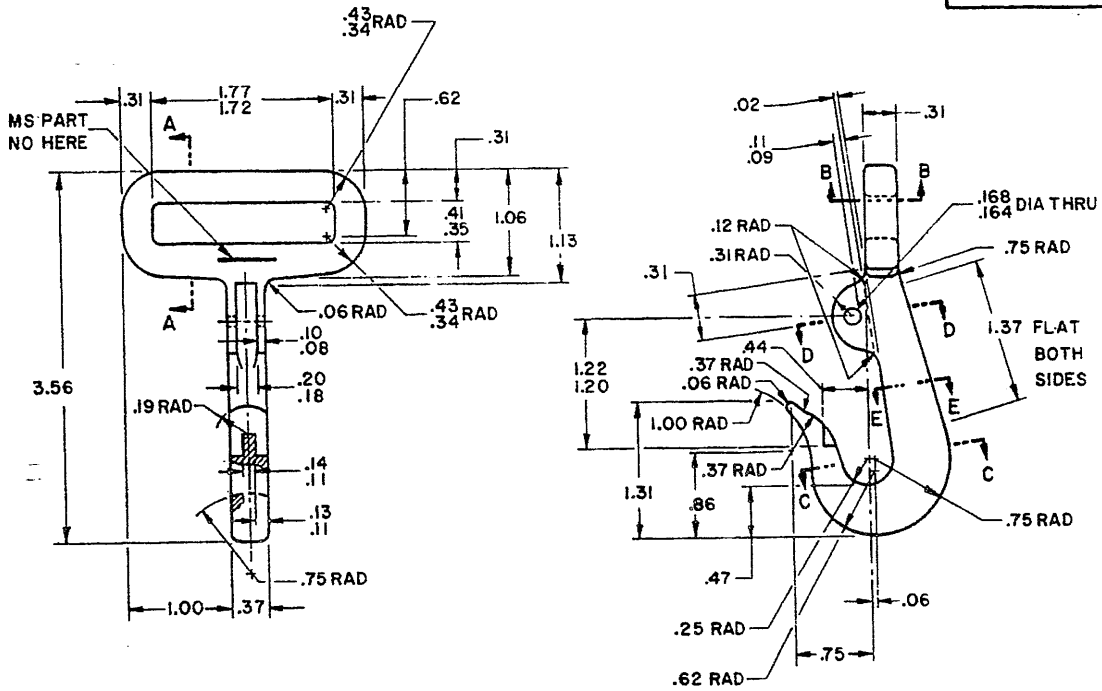

HOOK

User activities:
NAVY - MC
ARMY - AV

Review activities:
AIR FORCE - II

This military standard is approved for use by all Departments and Agencies of the Department of Defense. Selection for all new engineering and design applications and for repetitive use shall be made from this document.

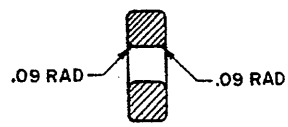

SECTION A-A



SECTION B-B

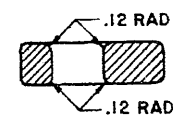

SECTION C-C

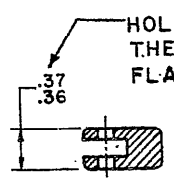

SECTION D-D

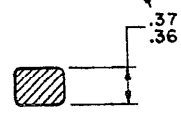

SECTION E-E

HOLD THIS DIMENSION WITHIN THE AREA DESIGNATED 1.37 FLAT BOTH SIDES.

" FOR CHANGES SEE SHEETS 1, 2 & 3.

APPROVED 12 MAY '61

| | | | |
|---|--|-------------------|--------|
| P.A. AIR FORCE-82 Other Cust NAVY-AS ARMY-GL | TITLE SNAP HOOK-QUICK CONNECTOR, PARACHUTE HARNESS | MILITARY STANDARD | |
| | | MS 22042 | |
| PROCUREMENT SPECIFICATION MIL-H-7195 | SUPERSEDES: AN6507 | SHEET | 2 OF 3 |

User activities:
NAVY - MC
ARMY - AV

Review activities:
AIR FORCE - II

This military standard is approved for use by all departments and agencies of the Department of Defense. Selection for all new engineering and design applications and for repetitive use shall be made from this document.

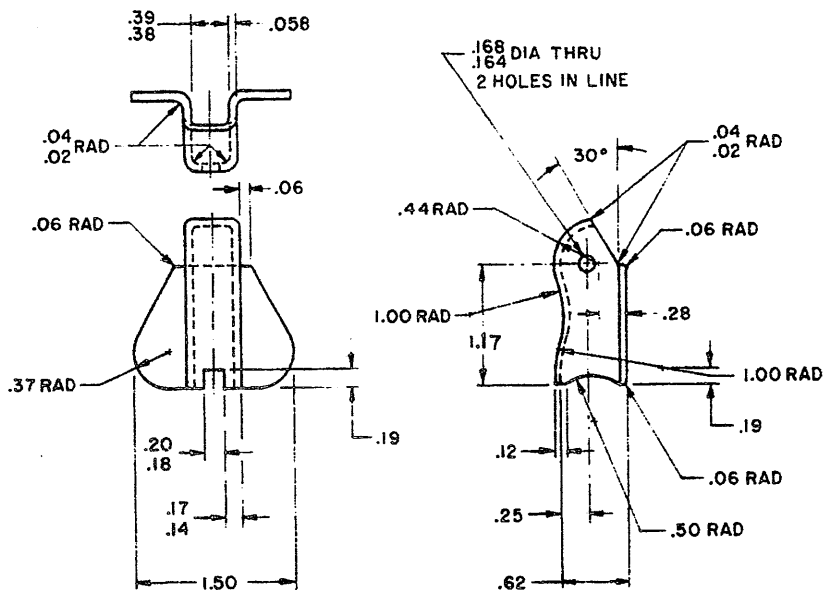

GUARD

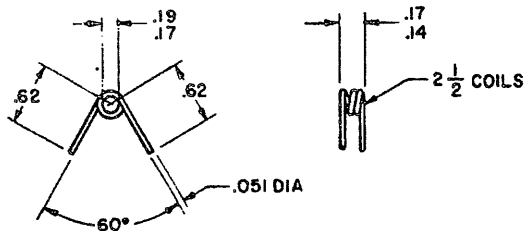

SPRING

APPROVED 12 MAY '61 FOR CHANGES SEE SHEETS 1, 2 & 3

| | | |
|---|--|-------------------|
| P.A. AIR FORCE-82 Other Cust NAVY-AS ARMY-GL | TITLE SNAP HOOK-QUICK CONNECTOR, PARACHUTE HARNESS | MILITARY STANDARD |
| | | MS22042 |
| PROCUREMENT SPECIFICATION MIL-H-7195 | SUPERSEDES. AN6507 | SHEET 3 OF 3 |