

INCH-POUND

MS21960C
 15 June 2000
 SUPERSEDING
 MS21960B
 13 June 1975

DETAIL SPECIFICATION SHEET

BODY, CLUSTER FITTING, THREE-WAY, INTERNAL BOSS

This specification is approved for use by all Departments and Agencies
 of the Department of Defense .

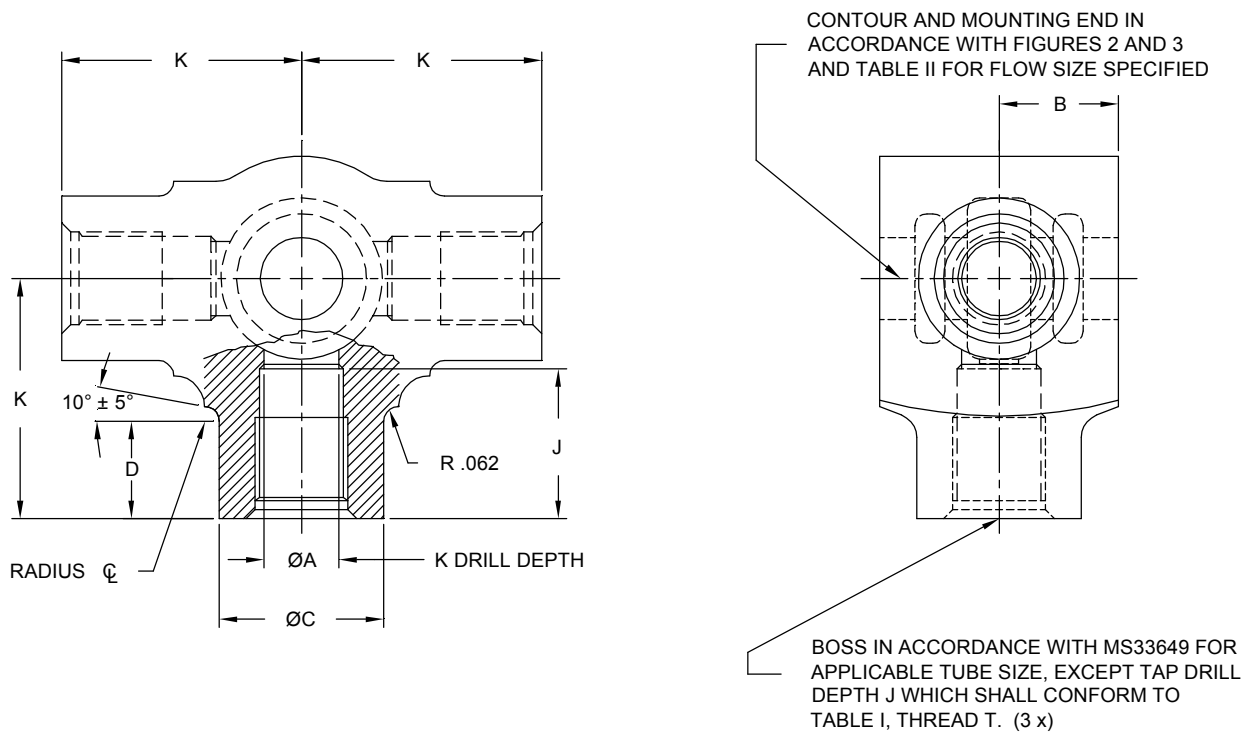

FIGURE 1. Body, cluster fitting.

MS21960C

TABLE IA. Dimensions for low flow sizes.

Low Flow Size		Tube OD	Thread T SAE AS8879	A	B	C ± .031	D ± .031	J	K
Al Alloy 7075	Al Alloy <u>1</u> / 2014/2024								
W4L	-4L	.250	.4375-20UNJF-3B	.312	.500	.688	.406	.625	1.062
W5L	-5L	.312	.500-20UNJF-3B	.344	.500	.750	.438	.625	1.094
W6L	-6L	.375	.5625-18UNJF-3B	.344	.500	.812	.469	.625	1.125

1/ Aluminum alloy 2014 and 2024 parts are cancelled. Use Aluminum alloy 7075 parts for new design. Cancelled parts may be used till stock is exhausted.

TABLE IB. Dimensions for high flow sizes.

High Flow Size		Tube OD	Thread T SAE AS8879	A	B	C ± .031	D ± .031	J	K
Al Alloy 7075	Al Alloy <u>1</u> / 2014/2024								
W4H	-4H	.250	.4375-20UNJF-3B	.312	.594	.688	.297	.625	1.21 9
W5H	-5H	.312	.500-20UNJF-3B	.375	.594	.750	.312	.625	1.25 0
W6H	-6H	.375	.5625-18UNJF-3B	.406	.594	.812	.375	.625	1.31 2
W8H	-8H	.500	.750-16UNJF-3B	.422	.594	1.125	.625	.750	1.50 0

1/ Aluminum alloy 2014 and 2024 parts are cancelled. Use Aluminum alloy 7075 parts for new design. Cancelled parts may be used till stock is exhausted.

MS21960C

CORNER ON R A MAY BE BROKEN .031 MAX

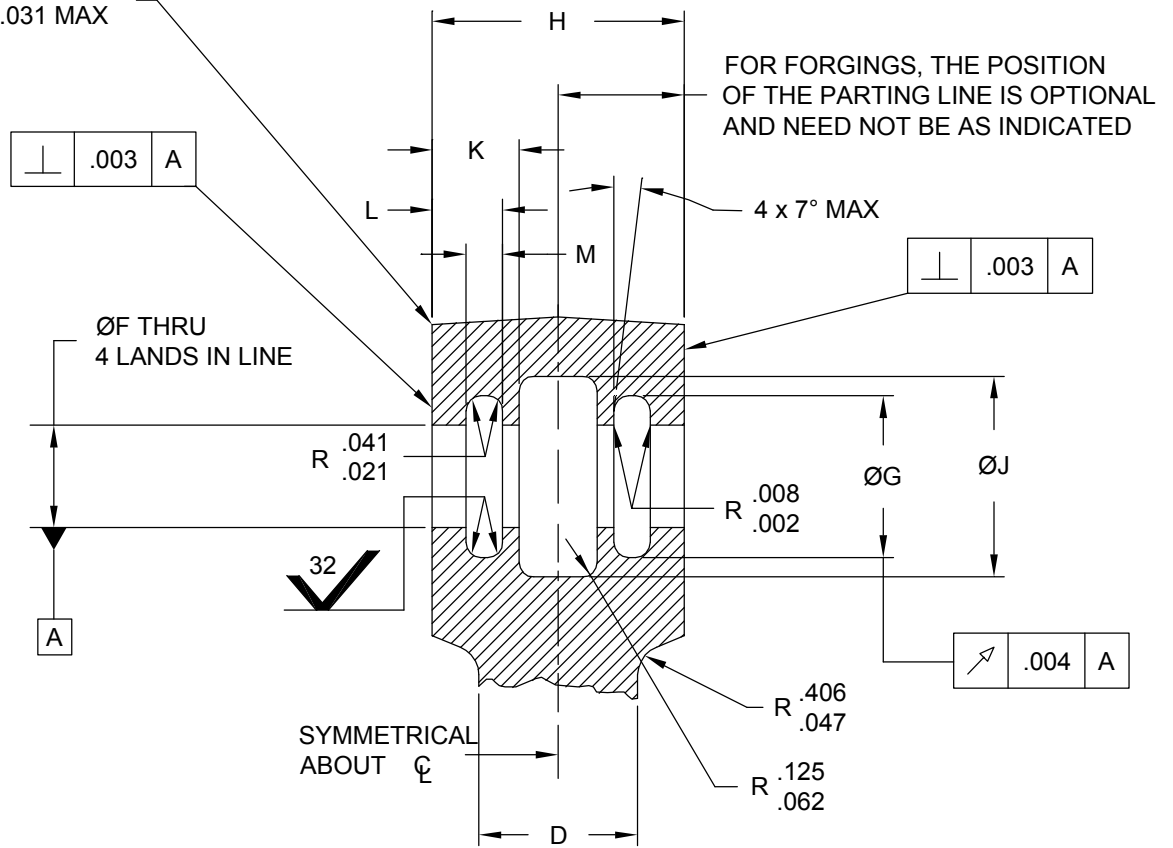

MOUNTING END DIMENSIONS

FIGURE 2. Mounting end.

MS21960C

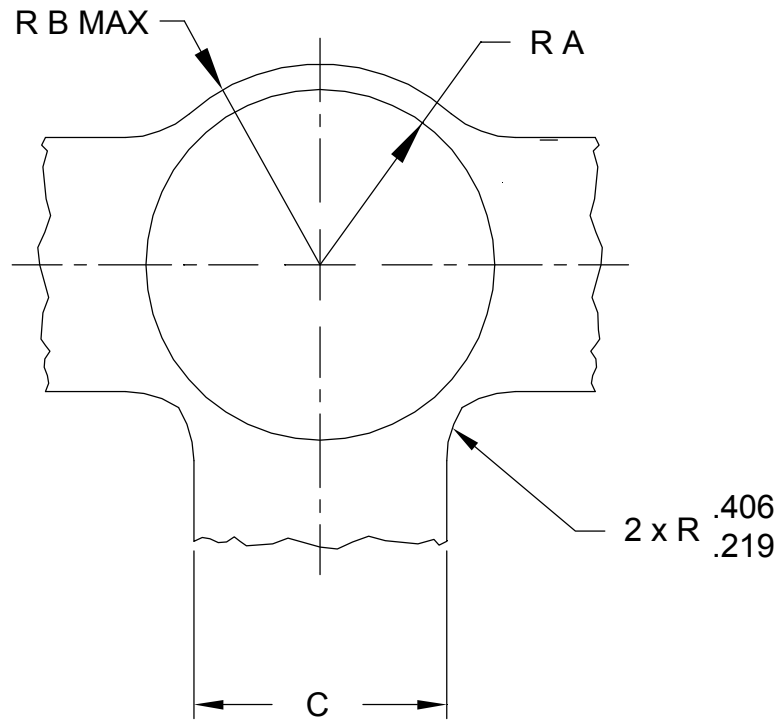

CONTOUR DIMENSIONS EXTERNAL

FIGURE 3. External contour.

MS21960C

TABLE II. Dimensions for contour and mounting end.

Type Fitting	A ± .031	B Max 1/	C Max 2/	D Max 2/	F ± .0005	G ± .004	H ± .005	J ± .010	K ± .010	L ± .004	M ± .005
Low Flow	.562	.636	.844	.995	.5000	.664	1.000	.797	.312	.249	.143
High Flow	.812	.909	1.156	1.188	.8125	1.045	1.188	1.078	.375	.283	.175

1/ B radius is the max envelope dimension for forging draft, flash, and other projections on A radius.

2/ Dimensions C and D represent the max envelope which shall be large enough to meet final part dimensions.

REQUIREMENTS:

1. The requirements for acquiring the product described herein shall consist of this specification sheet and SAE AS4875.
2. Material: Aluminum alloy extrusion, 7075-T73 per AMS-QQ-A-225/9. Aluminum alloy forging, 7075-T73 per AMS-QQ-A-367.
3. Finish: See acquisition standard SAE AS4875. Aluminum alloy 7075 fittings shall be dyed brown.
4. All machined surfaces shall be finished to 250 μin R_a maximum, unless otherwise specified. Surface finish shall be in accordance with ASME B46.1.
5. Fittings shall be free of all burrs and slivers.

NOTES:

1. Dimensions in inches. Unless otherwise specified, tolerances: decimals $\pm .010$, angles $\pm 1/2^\circ$.
2. Dimensioning and tolerancing per ASME Y14.5.
3. Part Identification number (PIN)

Example of PIN: MS21960W4L

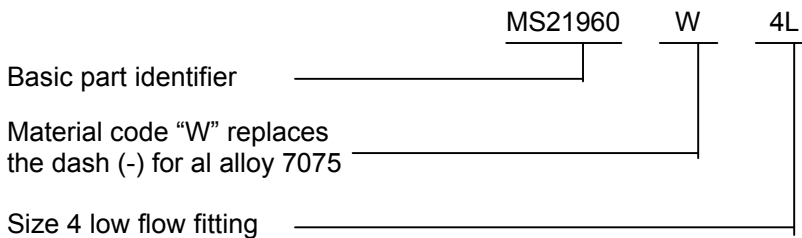

MS21960C

Custodians:
Air Force - 99
Navy - AS
DLA - CC

Preparing activity:
DLA - CC

(Project 4730-0822)

Review activities:
Air Force - 82
Navy - SA