

INCH-POUND

MS21344A

4 October 2016

SUPERSEDING

MS21344

17 August 1971

DETAIL SPECIFICATION SHEET

FITTINGS - INSTALLATION OF FLARED TUBE, STRAIGHT,
THREADED CONNECTORS, DESIGN STANDARD FOR

This specification is approved for use by all Departments and Agencies of the Department of Defense.

The requirements for acquiring the product described herein shall consist of this specification sheet.

REQUIREMENTS:

This is a design standard and shall not be used as a Part or Identifying Number.

Nominal use: Airframe fluid connections.

Prior to installation all fittings and components should be inspected for possible contamination or damage. Sealing surfaces should be smooth, no sharp edges on bulkhead hole, washers, or nuts excluding all threads. No cuts, gouges, or other visible damage should be on the gaskets or retainers.

Bulkhead and flared tube installation, see figure 1.

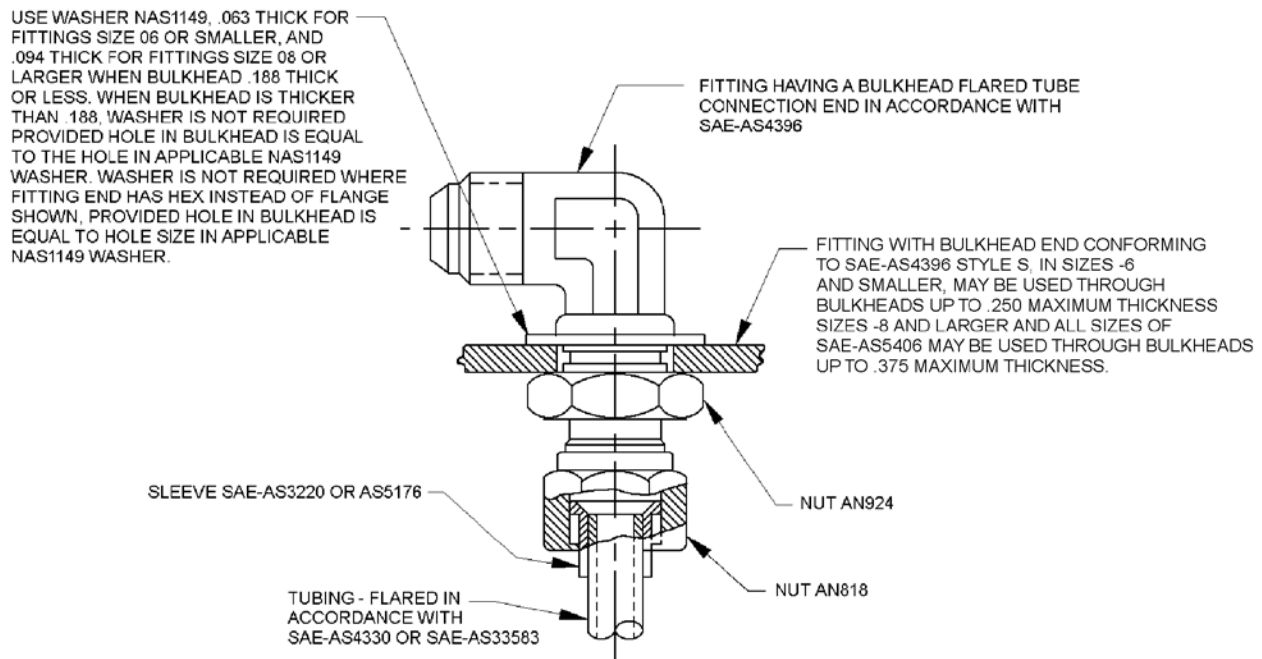

FIGURE 1. Bulkhead and flared tube installation.



MS21344A

Overtightening of hose and tube coupling nuts will cause thread and seal damage resulting in fitting leakage. Torque values are for threads lubricated with hydraulic fluid, anti-seize compound (A-A-59313), petrolatum (Vaseline), or aircraft and instrument grease (MIL-G-21164), as applicable.

Wrench torque values for tightening AN818 short coupling tube nut for the following hose assemblies, see table I:

MIL-DTL-8790 MIL-DTL-26666 SAE-AS38390
 MIL-DTL-8795 SAE-AS604
 MIL-DTL-25579 SAE-AS1339

TABLE I. Wrench torque values for tightening AN818 nut. 1/ 2/

Dash Number (ref)	Tubing OD	Aluminum-Alloy tubing Torque pound inch		Steel tubing Torque pound inch	
		Min	Max	Min	Max
-2	.125	20	30	75	85
-3	.188	25	35	95	105
-4	.250	50	65	135	150
-5	.313	70	90	170	200
-6	.375	110	130	270	300
-8	.500	230	260	450	500
-10	.625	330	360	650	700
-12	.750	460	500	900	1000
-16	1.000	500	700	1200	1400
-20	1.250	800	900	1520	1680
-24	1.500	800	900	1900	2100
-28	1.750	---	---	---	---
-32	2.000	1800	2000	2660	2940

1/ When the hose fitting (nipple and nut) is aluminum. The min/max torque values for aluminum tubing shall apply.

2/ When the hose fitting (nipple and nut) is steel. The min/max torque values for steel tubing shall apply.

Tubing end flared in accordance with SAE-AS33583 (double flare) aluminum- alloy tubing, for use on oxygen lines only. Torque values for AN818 nut, see table II. Do not lubricate fittings or gaskets.

TABLE II. SAE-AS33583 wrench torque values for tightening AN818 nut.

Dash Number (ref)	Tubing OD	Torque pound inch	
		Min	Max
-2	.125	---	---
-3	.188	---	---
-4	.250	100	125
-5	.313	200	250
-6	.375	300	400

SAE-AS4395 connection end (flared tube connection). Installation of fitting is similar, except that the end is not used through bulkheads. Wrench torque values for assembling the tubing are the same as shown in table II.

MS21344A

Procedure for installation of SAE-AS4395 fitting end, style E:

1. Lubricate appropriate gasket in appropriate liquid, see table III.
2. Install the gasket on the fitting as shown on figure 2, detail 1.
3. Screw the fitting assembly into the boss until it bottoms tightly on the boss as shown on figure 2, detail 2.

Non-positioning type fitting installation suitable for nominal operating pressures up to and including 3,000 psi.

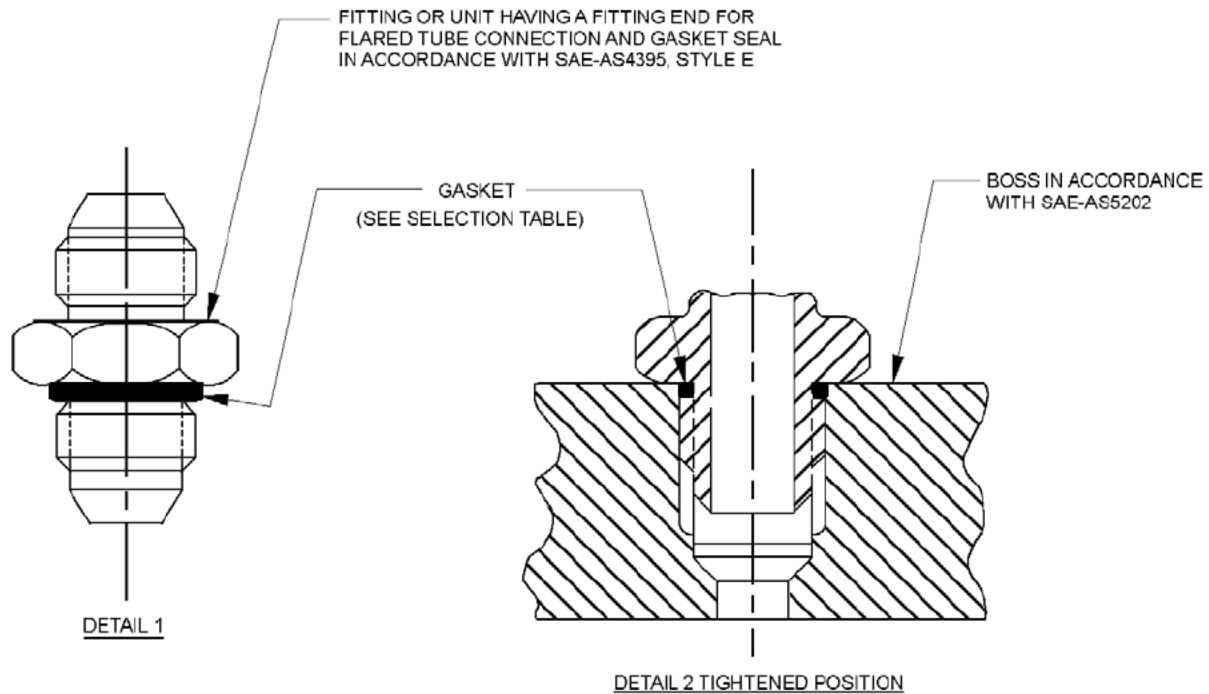

FIGURE 2. Non-positioning type fitting installation.

TABLE III. Gasket selection and lubricating liquid.

Application	Specification	Lubricating liquid
Hydraulic	SAE-AS28778	MIL-PRF-5606 MIL-PRF-87257 MIL-PRF-83282 Petrolatum (Vaseline)
Engine oil	SAE-AS28778	Engine oil
Fuel	SAE-AS29512	Applicable fuel
Pneumatic	SAE-AS28778	SAE-AMS-G-4343

Positing type universal fitting installation suitable for nominal operating pressures up to and including 3,000 psi, see figure 3.

MS21344A

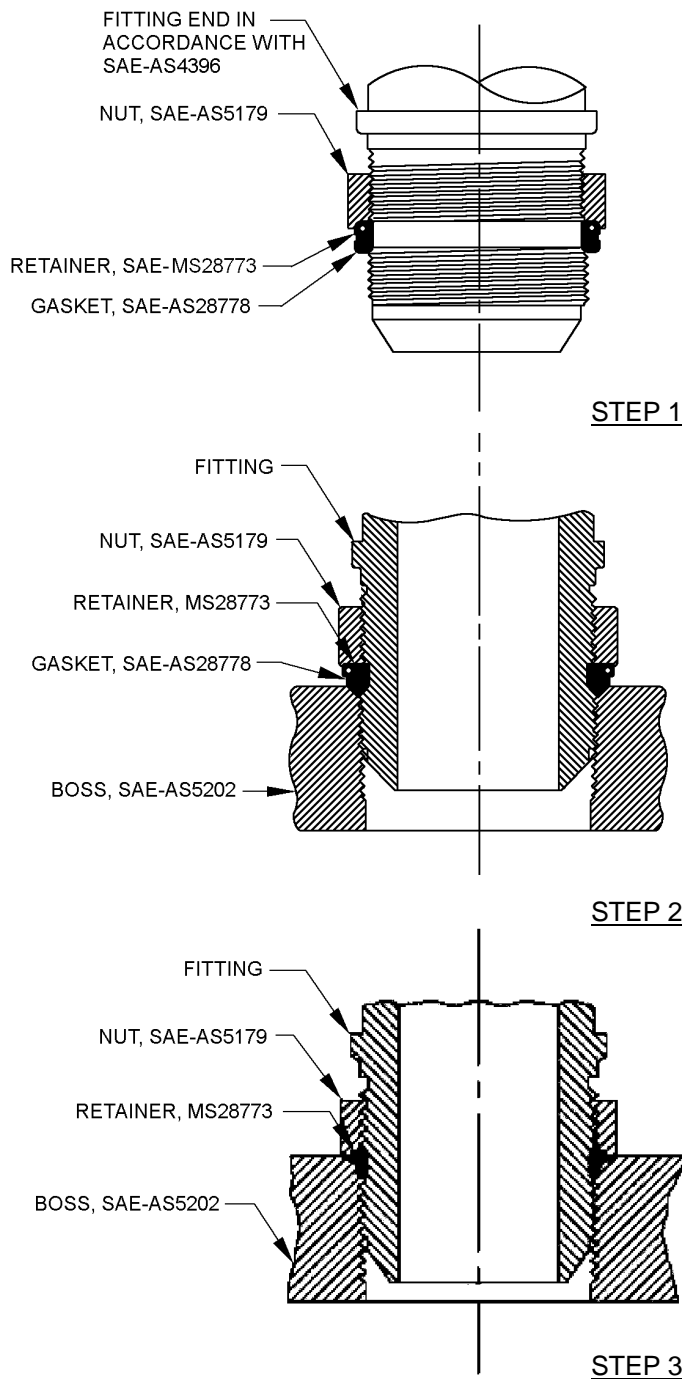

Coat male threads of fitting, retainer, and gasket sparingly with petrolatum (Vaseline), or hydraulic fluid and assemble as shown.

Work the retainer into the counter bore of the nut.

Work the gasket into the lower thread section of the fitting. Turn the nut, by hand, down (clockwise) until the gasket is pushed firmly against the retainer and lower threaded section of the fitting.

STEP 1

Align the fitting to the boss. Install the fitting, by hand, into the boss and at the same time **keep the nut turning with the fitting** until the gasket contacts the boss.

This point can be determined by a sudden increase in torque. If the fitting does not screw easily into the boss realign and try again.

With the fitting in this position, put a wrench on the nut to prevent its turning, and at the same time, using another wrench, turn the fitting in (clockwise) 1-1/2 turns.

STEP 2

Final positioning of the fitting is accomplished by turning in **not more than one additional turn**, tighten as described above.

With a wrench hold the fitting and using another wrench tighten the nut down tightly against boss.

Slight extrusion of the retainer is not detrimental.

STEP 3

FIGURE 3. Positing type universal fitting installation.

MS21344A

Damaged 37° ends, small nicks or defects, on the fitting that do not allow for proper sealing may be repaired by using A-A-59935 crush seals. They can also be used on first assembly to enhance mechanical sealing and to extend joint life. Torque requirements are specified in A-A-59935.

Changes from previous issue. Marginal notations are not used in this revision to identify changes with respect to the previous issue, due to the extent of the changes.

Referenced documents. This document references the following:

A-A-59313	MIL-PRF-83282	SAE-AS4396
A-A-59935	MIL-PRF-87257	SAE-AS5176
AN818	MS28773	SAE-AS5179
AN924	NAS1149	SAE-AS5202
MIL-DTL-8790	SAE-AMS-G-4343	SAE-AS5406
MIL-DTL-8795	SAE-AS604	SAE-AS28778
MIL-DTL-25579	SAE-AS1339	SAE-AS29512
MIL-DTL-26666	SAE-AS3220	SAE-AS33583
MIL-G-21164	SAE-AS4330	SAE-AS38390
MIL-PRF-5606	SAE-AS4395	

CONCLUDING MATERIAL

Custodians:

Army - AV
Navy - AS
Air Force - 99
DLA - CC

Preparing activity:
DLA - CC

(Project 4730-2016-086)

Review activities:

Army - AR, MI
Air Force - 71

NOTE: The activities listed above were interested in this document as of the date of this document. Since organizations and responsibilities can change, you should verify the currency of the information above using the ASSIST Online database at <https://assist.dla.mil>.