

INCH-POUND

MS21260N
 19 September 2011
 SUPERSEDING
 MS21260M
 5 November 2001

DETAIL SPECIFICATION SHEET

TERMINAL, WIRE ROPE, SWAGING, STUD

This specification sheet is approved for use by all Departments and Agencies of the Department of Defense.

The requirements for acquiring the product described herein shall consist of this specification sheet, MIL-DTL-781, and QPL-781.

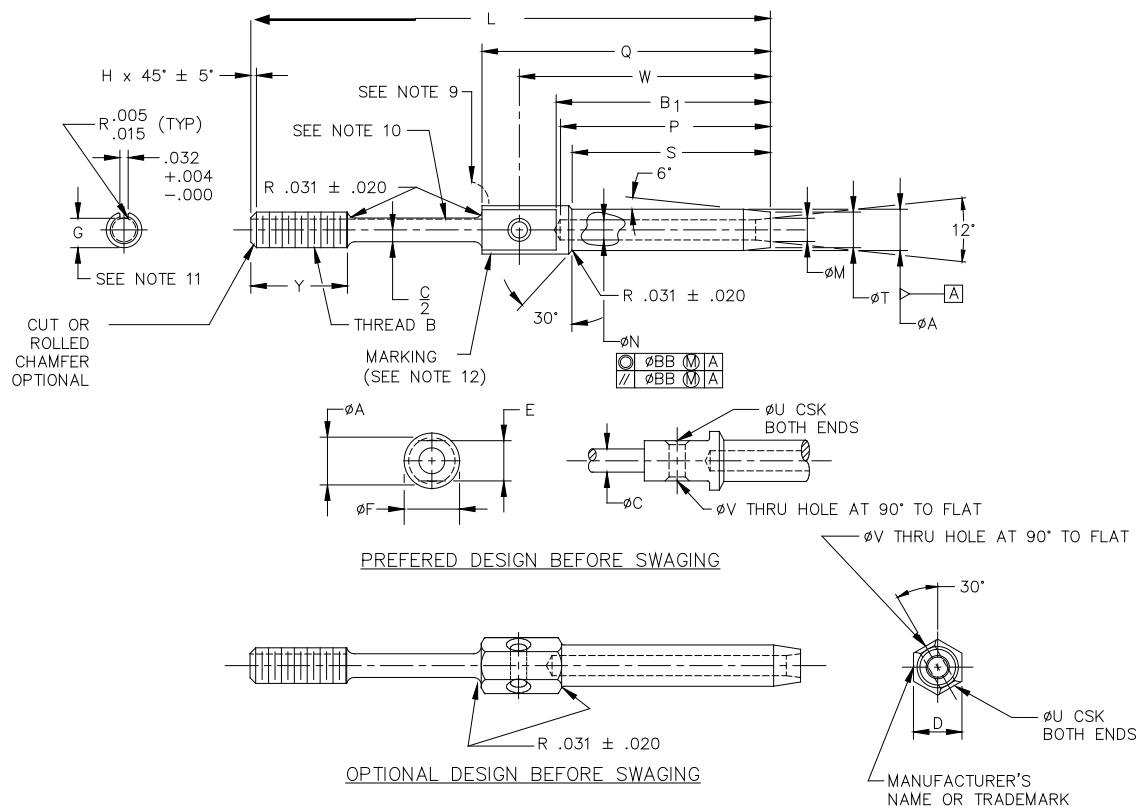

MS21260N

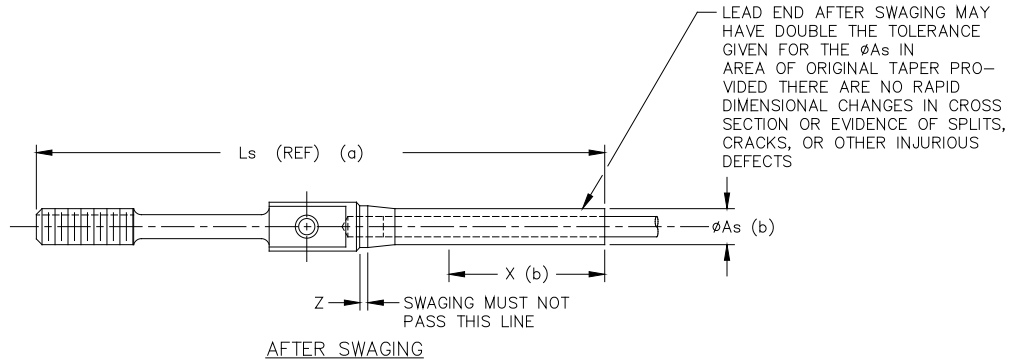

- NOTES: (a) Reference dimensions are for design purposes only and are not an inspection requirement.
 (b) Swaged terminals shall conform to ' ϕ_{As} ' for length X.

FIGURE 2. Terminal, wire rope, swaging, stud after swaging.

TABLE I. Dash numbers and dimensions.

Dash number		Wire rope diameter		Minimum breaking strength lb $\frac{1}{2}$	Thread B UN-3A UNF-3A	ϕA		ϕAs	
RH thread	LH thread	Nominal reference	Minimum						
L2RH	L2LH	1/16	0.062	480	0.1380 (# 6)-40	0.160	+0.000 -0.005	0.138	+0.000 -0.005
S2RH	S2LH							0.190	
L3RH	L3LH							0.219	
S3RH	S3LH	0.250							
L4RH	L4LH		1/8	0.125	2000	0.2500 (1/4)-28		0.250	
S4RH	S4LH								
L5RH	L5LH	5/32	0.156	2800	0.3125 (5/16)-24	0.297		0.313	
S5RH	S5LH								
L6RH	L6LH								
S6RH	S6LH	3/16	0.187	4200	0.3750 (3/8)-24	0.359		0.427	
-7RH	-7LH						7/32		0.218
-8RH	-8LH	1/4	0.250	7000	0.4375 (7/16)-20	0.563	0.500	+0.000 -0.008	
-9RH	-9LH	9/32	0.281	8000	0.5000 (1/2)-20	0.635	0.563		
-10RH	-10LH	5/16	0.312	9800	0.5625 (9/16)-18	0.703	0.625	+0.000 -0.009	
-12RH	-12LH	3/8	0.375	14400	0.6250 (5/8)-18	0.781	0.688		
-14RH	-14LH	7/16	0.437	17600	0.6250 (5/8)-18	0.844	0.750	+0.000 -0.010	
-16RH	-16LH	1/2	0.500	22800	0.7500 (3/4)-16	0.984	0.875		
-18RH	-18LH	9/16	0.562	28500	0.8750 (7/8)-14	1.109	1.000	+0.000 -0.012	
-20RH	-20LH	5/8	0.625	35000	1.0000 (1)-12	1.359	1.250		
-24RH	-24LH	3/4	0.750	49600	1.1250 (1 1/8)-12	1.593	1.437	+0.000 -0.010	
-28RH	-28LH	7/8	0.875	66500	1.2500 (1 1/4)-12	1.812	1.625		
-32RH	-32LH	1	1.000	85400					

1/ To achieve the minimum breaking strength, for the terminal test only, a galvanized carbon steel wire rope shall be used.

MS21260N

TABLE I. Dash numbers and dimensions - Continued.

Dash number		B ₁		∅C +.006 -.000	D	E	∅F	G		H	
RH thread	LH thread							Maximum	Minimum	Maximum	Minimum
L2RH	L2LH	1.042		0.092	0.188	0.156	0.188	0.1139	0.1094	0.031	0.015
S2RH	S2LH										
L3RH	L3LH	1.261		0.133	0.250	0.187	0.250	0.1638	0.1568		
S3RH	S3LH										
L4RH	L4LH	1.511		0.195	0.313	0.250	0.313	0.2224	0.2152		
S4RH	S4LH										
L5RH	L5LH	1.761		0.245	0.375	0.312	0.375	0.2830	0.2754		
S5RH	S5LH										
L6RH	L6LH	2.011		0.306	0.438	0.375	0.438	0.3454	0.3378		
S6RH	S6LH										
-7RH	-7LH	2.261	±0.063	0.361	0.625	0.563	0.625	0.4052	0.3972		
-8RH	-8LH	2.511									
-9RH	-9LH	2.761		0.406	0.688	0.625	0.688	0.4678	0.4597		
-10RH	-10LH	3.011									
-12RH	-12LH	3.511		0.476	0.750	0.688	0.750	0.5285	0.5201	0.063	
-14RH	-14LH	4.011									
-16RH	-16LH	4.698		0.538	0.812	0.750	0.812	0.5909	0.5826		
-18RH	-18LH	5.011									
-20RH	-20LH	5.511		0.654	1.000	0.875	1.000	0.7137	0.7050		
-24RH	-24LH	6.511									
-28RH	-28LH	7.166		1.002	1.438	1.125	1.438	0.9608	0.9516	0.078	
-32RH	-32LH	8.229									
				1.128	1.875	1.625	1.812	1.2069	1.1972	0.094	0.062

TABLE I. Dash numbers and dimensions - Continued.

Dash number	L ±0.063	Ls reference	∅M		∅N		P		Q +0.031 -0.016	S +0.062 -0.000	∅T	
L2	3.491	3.67	0.090		0.078		1.042		1.319	0.969	0.138	+0.000 -0.005
S2	2.616	2.79										
L3	3.738	3.86	0.119		0.109		1.261		1.581	1.188	0.190	
S3	2.863	2.98										
L4	4.020	4.28	0.154		0.141		1.511		1.863	1.438	0.219	
S4	3.145	3.40										
L5	4.314	4.66	0.188	+0.010 -0.000	0.172	+0.005 -0.000	1.761	+0.031 -0.000	2.157	1.688	0.250	
S5	3.439	3.78										
L6	4.612	4.78	0.223		0.203		2.011		2.455	1.938	0.313	
S6	3.737	3.90										
-7	4.914	5.21	0.257		0.234		2.261		2.757	2.188	0.375	+0.000
-8	5.218	5.52	0.291		0.265		2.511		3.061	2.438	0.438	-0.007
-9	5.542	5.90	0.326		0.297		2.761		3.385	2.688	0.500	+0.000 -0.008
-10	5.875	6.30	0.360		0.328		3.011		3.718	2.938	0.563	
-12	6.608	7.01	0.430	+0.012 -0.000	0.404	+0.008	3.511	+0.047 -0.000	4.281	3.438	0.625	
-14	7.468	7.94	0.514		0.468	-0.000	4.011		4.812	3.938	0.688	
-16	8.718	9.28	0.584		0.531	+0.009	4.698		5.562	4.625	0.750	+0.000
-18	9.188	9.78	0.653		0.594	-0.000	5.011		6.000	4.938	0.875	-0.009
-20	10.469	11.16	0.722	+0.015 -0.000	0.656	+0.010 -0.000	5.511	+0.062 -0.000	6.750	5.438	1.000	+0.000 -0.010
-24	12.188	12.76	0.860		0.781	+0.012 -0.000	6.511		7.938	6.438	1.250	
-28	12.851	13.61	1.013		0.921	+0.012 -0.000	7.166		8.601	7.094	1.437	+0.000 -0.012
-32	14.624	15.53	1.151		1.046	8.229	9.844		8.156	1.625		

MS21260N

TABLE I. Dash numbers and dimensions - Continued.

Dash number	ØU reference	ØV ±0.005	W ±0.016	X	Y ±0.047	Z	ØBB
				Minimum	2/	Minimum	
L2	0.094	0.063	1.174	0.70	0.375	0.03	0.008 (0.016 FIM)
S2							
L3			1.411	0.80	0.500		
S3							
L4	0.125	0.098	1.682	1.05	0.563		
S4							
L5			1.958	1.29	0.625		
S5							
L6			2.237	1.31	0.750		
S6							
-7			2.518	1.55	0.875		
-8			2.784	1.70			
-9			3.076	1.89	1.000		
-10			3.326	2.06			
-12	3.828	3.12	1.125				
-14	4.375	3.57					
-16	0.188	0.125	5.093	4.31	1.250	0.010 (0.020 FIM)	
-18			5.468	4.51	1.500		
-20			6.093	5.04	1.750	0.015 (0.030 FIM)	
-24			7.188	5.80	2.000		
-28			7.846	6.31		2.250	0.020 (0.040 FIM)
-32			9.000	7.26			

2/ Includes last full thread engagement.

REQUIREMENTS:

1. Material: Material shall be in accordance with MIL-DTL-781
2. Finish: Finish shall be in accordance with MIL-DTL-781.
3. Threads: Threads shall be in accordance with FED-STD-H28/20.
4. Swage: Swage shall be in accordance with MIL-DTL-6117.
5. Tolerances: Unless otherwise specified, tolerances: decimals ± 0.010 , angles $\pm 3^\circ$.

NOTES:

1. The part or identifying number (PIN) to be used for terminals acquired to this specification is created as shown below. An "L" in lieu of dash indicates long; an "S" in lieu of a dash indicates short. The two letters following the dash number or letters "L" or "R" indicates direction of thread (left or right hand).

MS21260N

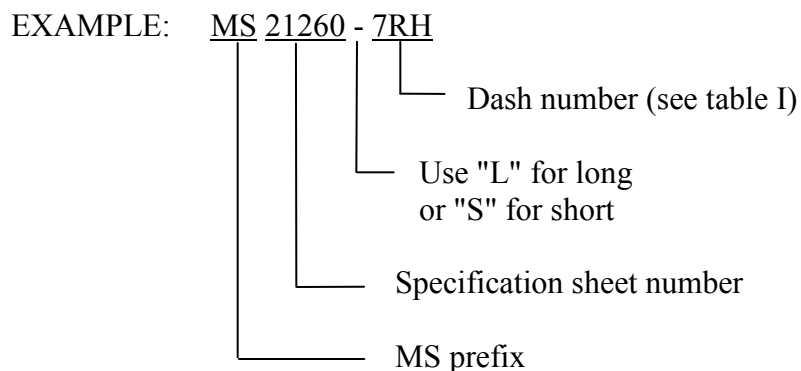

MS21260L2RH Indicates - Terminal, 0.1380 (#6)-40 right hand thread, long.
MS21260-7RH Indicates - Terminal, 0.3750 (3/8)-24 right hand thread.

2. Dimensions are in inches.
3. Remove burrs and sharp edges. (See MIL-DTL-781.)
4. Interpret drawing in accordance with ASME Y14.5M.
5. In the event of a conflict between the text of this document and the references cited herein, the text of this document takes precedence.
6. Unless otherwise specified, issues of reference documents are those in effect at the time of solicitation.
7. Interchangeability relationship: MS21260 parts can universally replace the canceled AN669 and NAS650 parts identified by the same dash number; but the canceled AN669 and NAS650 parts cannot replace the superseding MS21260 parts. MS21260 corrosion resistant steel parts can universally replace the canceled carbon and alloy steel parts identified by the same dash number.
8. Carbon and alloy steel parts are inactive for new design.
9. Cutter radius mark, which is used as a clip slot alignment indicator, must be present on this surface.
10. During fabrication of the clip slot groove, operation of the cutter shall be maintained for the length of the terminal shank until engagement of the wrenching shoulder surface occurs (see note 9). Depending upon the part tolerance conditions, the cutter radius marks may or may not appear on shank surface and shall not be cause for rejection.
11. Locking clip slot (dimension G) is optional for sizes -12 and above.
12. Marking: Complete MS part number, indented. Use two faces if required. For terminal sizes -2 through -5, use basic part number only, example, MS21260.

MS21260N

CHANGES FROM PREVIOUS ISSUE: The margins of this specification are marked with vertical lines to indicate where changes from the previous issue were made. This was done as a convenience only and the Government assumes no liability whatsoever for any inaccuracies in these notations. Bidders and contractors are cautioned to evaluate the requirements of this document based on the entire content irrespective of the marginal notations and relationship to the last previous issue.

Custodians:

Army - CR4
Navy - AS
Air Force - 99
DLA - GS

Preparing Activity:

DLA - GS5

(Project 1640-2011-011)

Review Activities:

Navy - MC
Air Force - 71

NOTE: The activities listed above were interested in this document as of the date of this document. Since organizations and responsibilities can change, you should verify the currency of the information above using the ASSIST database at <https://assist.daps.dla.mil/>.