

INCH-POUND

MS21256G
w/AMENDMENT 1
8 March 2011

SUPERSEDING
MS21256G
11 July 2003

DETAIL SPECIFICATION SHEET

CLIP, LOCKING, TURNBUCKLE

This specification is approved for use by all Departments and Agencies of the Department of Defense.

The requirements for acquiring the product described herein shall consist of this specification sheet, MIL-DTL-8878, and QPL-8878.

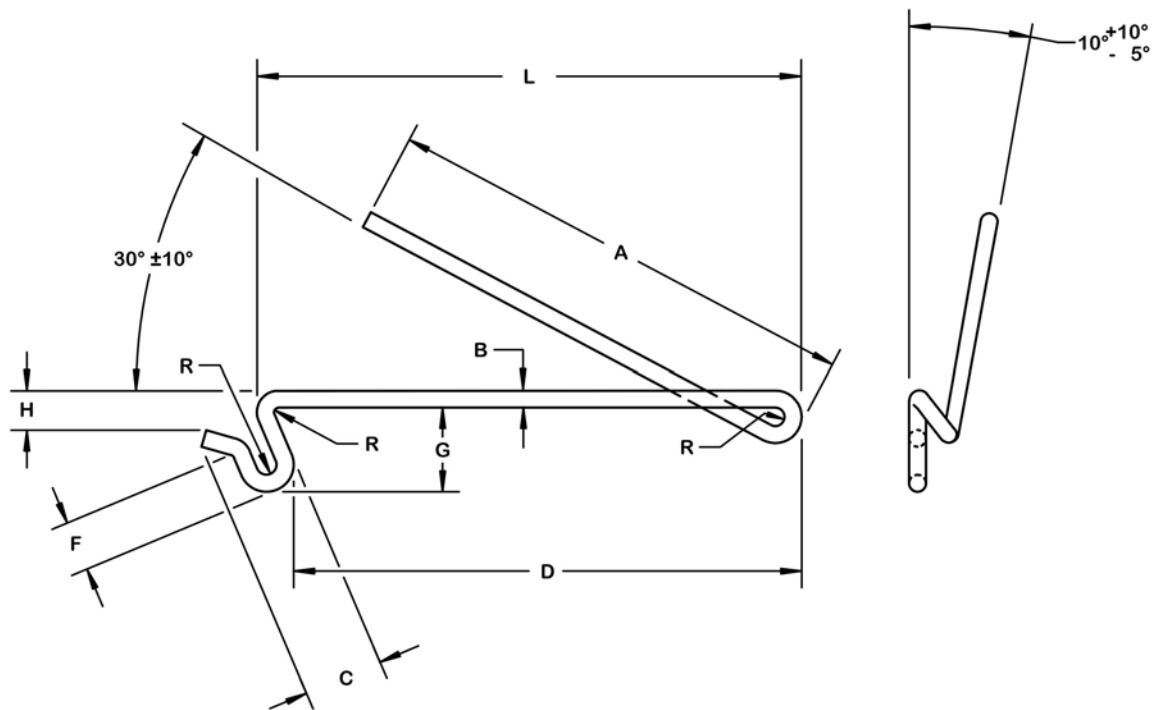

FIGURE 1. Clip, locking, turnbuckle.

MS21256G
w/AMENDMENT 1

TABLE I. Dash numbers and dimensions.

Dash number	A 1/	ØB ±0.0005	C +0.010 -0.015	D	F	G	H	L	R radius
-1	0.965	0.0286	0.150	1.078	0.125	0.300	0.165	1.115	0.032
-2	1.875	0.0286		1.955		0.315	0.180	2.000	
-3	2.045	0.0286	0.215	2.015	0.150	0.430	0.275	2.140	

1/ Dimension A must be held without distortion at end.

REQUIREMENTS:

1. Dimensions: Dimensions are prior to coating and in inches.
2. Tolerances: Unless otherwise specified, tolerances: decimals ± 0.015 ; all internal radii are $0.032 +0.000/-0.015$.
3. Material: Corrosion resistant steel wire shall be in accordance with MIL-DTL-8878.
4. Marking: Marking shall be in accordance with MIL-DTL-8878.
5. Ends: Ends of locking clip shall be cut square and shall be free of burrs.

NOTES:

1. The part or identifying number (PIN) consists of the letters MS, the specification sheet number, and a dash number taken from table I.

EXAMPLE: MS 21256 - 1

└─── Dash number

└─── Specification sheet number

└─── MS prefix

MS21256-1 Indicates - Clip, turnbuckle, 0.965 long.

2. Locking clips are for one time use only and shall not be reused or altered. For lock clipping of aircraft turnbuckles, see MS33736 and MIL-DTL-8878.
3. Stock manufactured to the previous revision shall be acceptable for 24 months after the date of this revision.
4. In the event of a conflict between the text of this document and the references cited herein, the text of this document takes precedence.

MS21256G
w/AMENDMENT 1

AMENDMENT NOTATIONS: The margins of this specification are marked with vertical lines to indicate where modifications from this amendment were made. This was done as a convenience only and the Government assumes no liability whatsoever for any inaccuracies in these notations. Bidders and contractors are cautioned to evaluate the requirements of this document based on the entire content irrespective of the marginal notations.

Custodians:

Army - CR4
Navy - AS
Air Force - 99
DLA - GS

Preparing Activity:

DLA - GS5

(Project 1640-2011-007)

Review Activity:

Air Force - 71

NOTE: The activities listed above were interested in this document as of the date of this document. Since organizations and responsibilities can change, you should verify the currency of the information above using the ASSIST database at <https://assist.daps.dla.mil/>.