

THE REQUIREMENTS FOR ACQUIRING THE PRODUCT(S) DESCRIBED HEREIN SHALL CONSIST OF THIS SPECIFICATION SHEET AND THE ISSUE OF THE FOLLOWING SPECIFICATION LISTED IN THAT ISSUE OF THE DODISS SPECIFIED IN THE SOLICITATION: MIL-I-8878

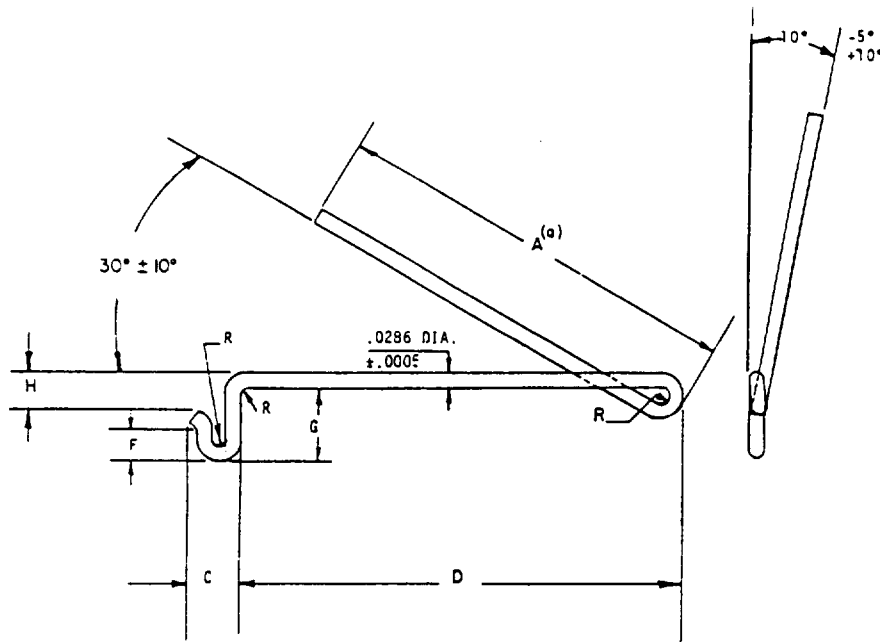

DASH NO	(a) A	C +.010 -.015	D	F	G	H	R RAD
-1	.965		1.078		.300	.165	.032
-2	1.875	.150	1.955	.125	.315	.180	
-3	2.045	.215	2.015	.150	.430	.275	

(a) DIMENSION A MUST BE HELD WITHOUT DISTORTION AT END

REQUIREMENTS:

DIMENSIONS ARE PRIOR TO COATING AND IN INCHES.

UNLESS OTHERWISE SPECIFIED; TOLERANCE: DECIMALS ±.015; ALL INTERNAL RADII ARE .032 +.000/-.015.

MATERIAL: CORROSION RESISTANT STEEL WIRE, ASTM A313, COMPOSITION 302 (UNS S30200), CONDITION B.

FINISH: SEE PROCUREMENT SPECIFICATION.

ENDS OF LOCKING CLIP SHALL BE CUT SQUARE AND SHALL BE FREE OF BURRS.

NOTES:

LOCKING CLIPS ARE FOR ONE TIME USE ONLY AND SHALL NOT BE REUSED OR ALTERED. FOR LOCK CLIPPING OF AIRCRAFT TURNBUCKLES, SEE MS33736.

STOCK MANUFACTURED TO THE PREVIOUS REVISION SHALL BE ACCEPTABLE FOR 24 MONTHS AFTER THE DATE OF THIS REVISION.

EXAMPLE OF PART NUMBER: MS21256-1 = CLIP, TURNBUCKLE, .965 LONG.

THIS STANDARD TAKES PRECEDENCE OVER DOCUMENTS REFERENCED HEREIN.

REVISION LETTERS ARE NOT USED TO DENOTE CHANGES DUE TO THE EXTENSIVENESS OF THE CHANGES.

INCH-POUND

PREPARING ACTIVITY: AIR FORCE - 82
CUSTODIANS: ARMY - AV NAVY - AS
AIR FORCE - 99 DLA.

MILITARY SPECIFICATION SHEET

TITLE

**CLIP, LOCKING,
TURNBUCKLE**

SPECIFICATION SHEET NUMBER

MS21256, REV D 20 Oct 94

SUPERSEDED BY
MS21256, REV C 1 MAR 83

AMSC - N/A FSC - 5340

REVIEW: DLA - IS
USER: NAVY - MC
PROJECT NUMBER: 5340-1921

DISTRIBUTION STATEMENT A. APPROVED FOR PUBLIC RELEASE, DISTRIBUTION IS UNLIMITED.

PAGE 1 OF 1

THIS SPECIFICATION IS APPROVED FOR USE BY ALL DEPARTMENTS AND AGENCIES OF THE DEPARTMENT OF DEFENSE.