

INCH-POUND

MS20813F
w/AMENDMENT 1
30 June 2014
SUPERSEDING
MS20813F
04 November 2011

MILITARY SPECIFICATION SHEET

CAP, PNEUMATIC VALVE, HIGH PRESSURE

Reactivated after 4 November 2011 and may be used for new and existing designs and acquisitions

This specification is approved for use by all Department and Agencies of the Department of Defense.

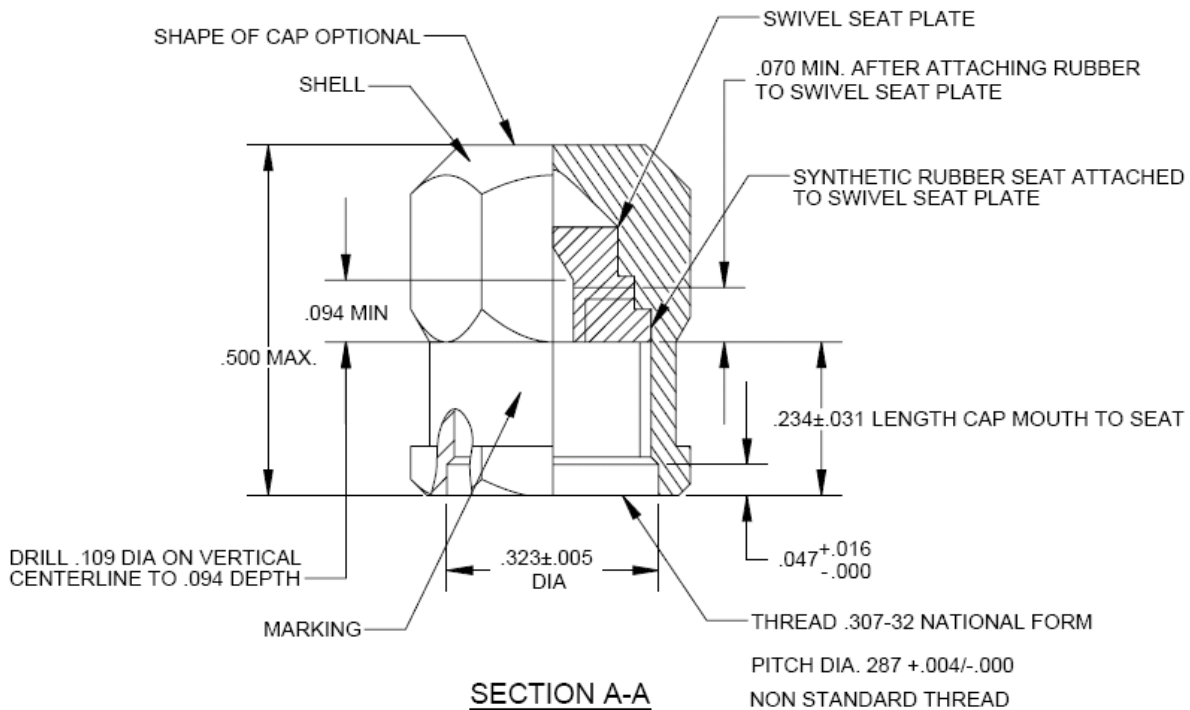
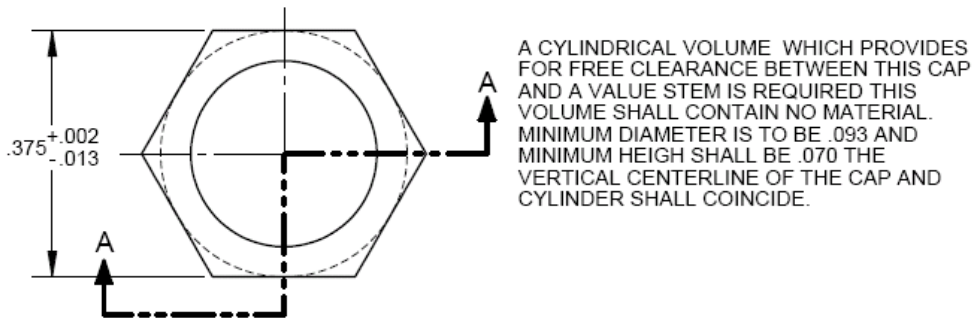

DASH NO.	FIIN
-1	

MS20813F

Notes:

1. Dimensions in inches. Unless otherwise specified, tolerances decimals $\pm .016$.
2. Remove all burrs and sharp edges.
3. Material:

Shell and swivel seat plate brass, specification ASTM-B16/B16M.

4. Finish:

Permanent non-flaking yellow lacquer external surface of cap.

5. For acceptable products, see QPL-5500.
6. Reference to international standardization agreement deleted.
7. This standard takes precedence over documents referenced herein. Referenced documents shall be of the issue in effect on date of invitations for bid.
8. Amendment notations. The margins of this specification are marked with vertical lines to indicate modifications generated by this amendment. This was done as a convenience only and the Government assumes no liability whatsoever for any inaccuracies in these notations. Bidders and contractors are cautioned to evaluate the requirements of this document based on the entire content irrespective of the marginal notations.

CONCLUDING MATERIAL

Custodians:

Army - AV
Navy - AS
Air Force - 71

Preparing activity:

Air Force - 71

(Project 1650-2014-002)

Review activities

Air Force - 99
DLA-GS

NOTE: The activities listed above were interested in this document as of the date of this document. Since organization and responsibilities can change, you should verify the currency of the information above using the ASSIST Online database at <https://assist.dla.mil>.