

PED SUP CLASS
1650

USER ACTIVITIES: ARMY AT

REVIEWER ACTIVITIES

DISTRIBUTION STATEMENT A. APPROVED FOR PUBLIC RELEASE; DISTRIBUTION IS UNLIMITED

AMSC N/A
This military standard is approved for use by all Departments and Agencies of the Department of Defense. Selection for all new engineering and design applications and for repetitive use shall be made from this document when applicable.

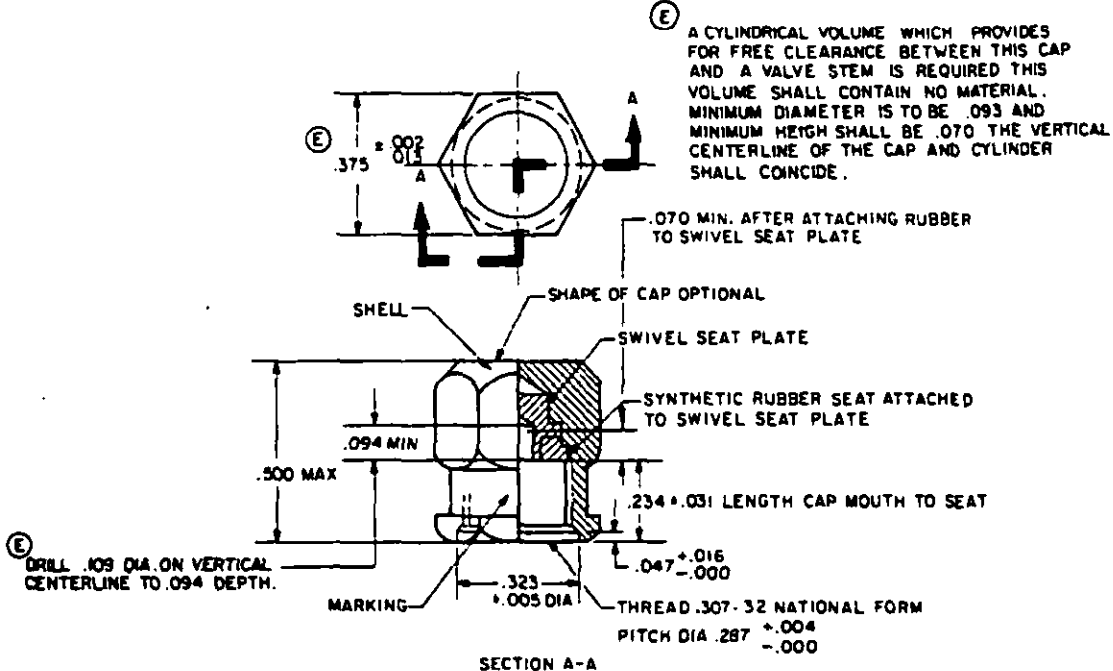

DASH NO.	FIN
-1	

MATERIAL: SHELL AND SWIVEL SEAT PLATE: BRASS, SPECIFICATION QQ-B-626, COMPOSITION 860.
FINISH: PERMANENT NONFLAKING YELLOW LACQUER EXTERNAL SURFACE OF CAP
REMOVE ALL BURRS AND SHARP EDGES
DIMENSIONS IN INCHES. UNLESS OTHERWISE SPECIFIED, TOLERANCES: DECIMALS ±.016
PART NUMBER MS20813-1 REPLACES AND IS INTERCHANGEABLE WITH AN813-1B
FOR ACCEPTABLE PRODUCTS, SEE OPL-5500.

REFERENCE TO INTERNATIONAL STANDARDIZATION AGREEMENT DELETED.

THIS STANDARD TAKES PRECEDENCE OVER DOCUMENTS REFERENCED HEREIN
REFERENCED DOCUMENTS SHALL BE OF THE ISSUE IN EFFECT ON DATE OF INVITATIONS
FOR BID.

APPROVED 1 APR 57 REVISED 30 AUG 63 23 APR 75 29 JULY 77 6 JUNE 86 26 AUG 87

P. A. AF-77	INTERNATIONAL INTEREST	TITLE	MILITARY STANDARD
Other Code NAVY-AS AF-33 ARMY-AV		CAP, PNEUMATIC VALVE, HIGH PRESSURE	MS20813
PROCUREMENT SPECIFICATION MIL-C-3500	SUPERSEDES AN813		SHEET 1 OF 1