

INCH-POUND

MS20500G
 29 August 2012
 SUPERSEDING
 MS20500F
 15 August 2011

DETAIL SPECIFICATION SHEET

NUT, SELF LOCKING, HEXAGON 1200°F, 125 KSI FTU

This specification is approved for use by all Departments and Agencies of the Department of Defense.

The requirements for acquiring the product described herein shall consist of this specification sheet and NASM7873.

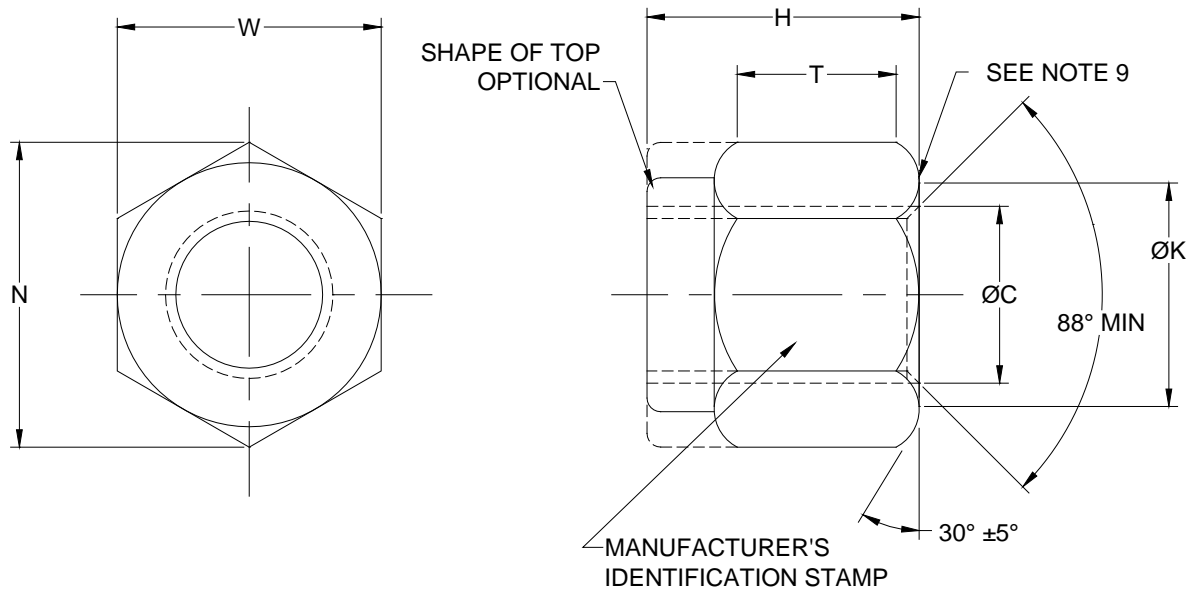

FIGURE 1. Nut.

MS20500G

TABLE I. Dash Numbers, Dimensions and Strengths.

DASH NO.	THREAD AS8879	ØC ±.020	H		ØK MIN	N MIN	T MIN	W		AXIAL STRENGTH LBS MIN	WEIGHT LBS/100 MAX
			MAX	MIN				MAX	MIN		
1032	.1900-32UNJF-3B	.210	.250	.202	.347	.413	.085	.376	.367	2,460	.64
428	.2500-28UNJF-3B	.273	.328	.280	.410	.488	.116	.439	.430	4,580	1.08
524	.3125-24UNJF-3B	.335	.360	.312	.472	.557	.123	.502	.492	7,390	1.56
624	.3750-24UNJF-3B	.398	.469		.533	.628	.153	.564	.553	11,450	2.28
(a) 720	.4375-20UNJF-3B	.467	.469	.421	.659	.698	.178	.627	.615	15,450	3.52
720A											
820	.5000-20UNJF-3B	.531	.610	.562	.721	.840	.221	.752	.741	21,110	4.92
918	.5625-18UNJF-3B	.594	.704	.656	.845	.982	.243	.877	.865	26,810	7.68
1018	.6250-18UNJF-3B	.656	.766	.718	.908	1.051	.274	.940	.928	34,130	9.48
1216	.7500-16UNJF-3B	.787	.891	.843	1.032	1.191	.316	1.064	1.052	50,020	13.25
1414	.8750-14UNJF-3B	.918	1.016	.968	1.219	1.404	.570	1.252	1.239	68,440	23.40
1612	1.0000-12UNJF-3B	1.044	1.141	1.093	1.407	1.615	.635	1.440	1.427	90,000	31.02
(a) 4614	1.0000-14UNC-3B										

(a) Inactive for design after 17 Nov. 1967

Requirements:

1. Materials: Heat resistant and corrosion resistant steel in accordance with SAE AMS 5642 (UNS S34720, S34723), SAE AMS 5646 (UNS S34700), SAE AMS 5732 (UNS S66286), or SAE AMS 5737 (UNS S66286).
2. Surface Coating: silver plate in accordance with SAE AMS 2410, plate thickness on external surface shall not be less than .0002 inch. Threads shall show complete coverage but thickness requirements on threads are waived.
3. Surface Texture: Surface texture in accordance with ASME B46.1. unless otherwise specified surface roughness shall not be greater than Ra 125.

Notes:

1. Threads in accordance with SAE AS8879.
2. Dimensions across flats include deformation of self-locking device.
3. These nuts shall be used in accordance with NASM33588.
4. Unless otherwise specified dimensions in inches.
5. Break all sharp edges and remove all hanging burrs and slivers.
6. MS20500-720A items can universally replace the inactive MS20500-720 items but the inactive MS20500-720 items cannot always replace the superseding MS20500-720A items.
7. Example of part number:

MS20500 - 428 - Nut, Self-Locking, .2500-28, Heat Resistant and CRES Nut, Silver Plated

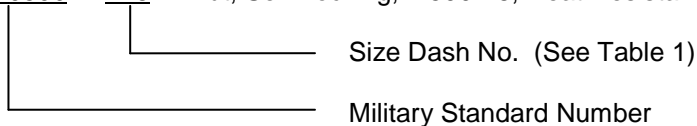

8. For design feature purposes, this standard takes precedence over procurement documents referenced herein.

MS20500G

9. Washer face, chamfer, or radius relief to hex flats are optional provided the $30^\circ \pm 5^\circ$ angle and “ØK” dimensions are maintained.
10. Changes from previous issue. Marginal notations are not used in this revision to identify changes with respect to the previous issue due to the extent of the changes.

Custodians:
Army - AV
Navy - AS
Air Force - 99

Preparing activity:
DLA - IS

(Project 5310-2012-004)

NOTE: The activities listed above were interested in this document as of the date of this document. Since organizations and responsibilities can change, you should verify the currency of the information above using the ASSIST Online database at <https://daps.dla.mil>.