

INCH-POUND

MS20270D
 2 March 2006
 SUPERSEDING
 MS20270C
 15 June 1995

DETAIL SPECIFICATION SHEET

JOINT-UNIVERSAL, PLAIN, LIGHT DUTY

This specification is approved for use by all Departments and Agencies of the Department of Defense.

The requirements for acquiring the product described herein shall consist of this specification sheet and MIL-DTL-6193.

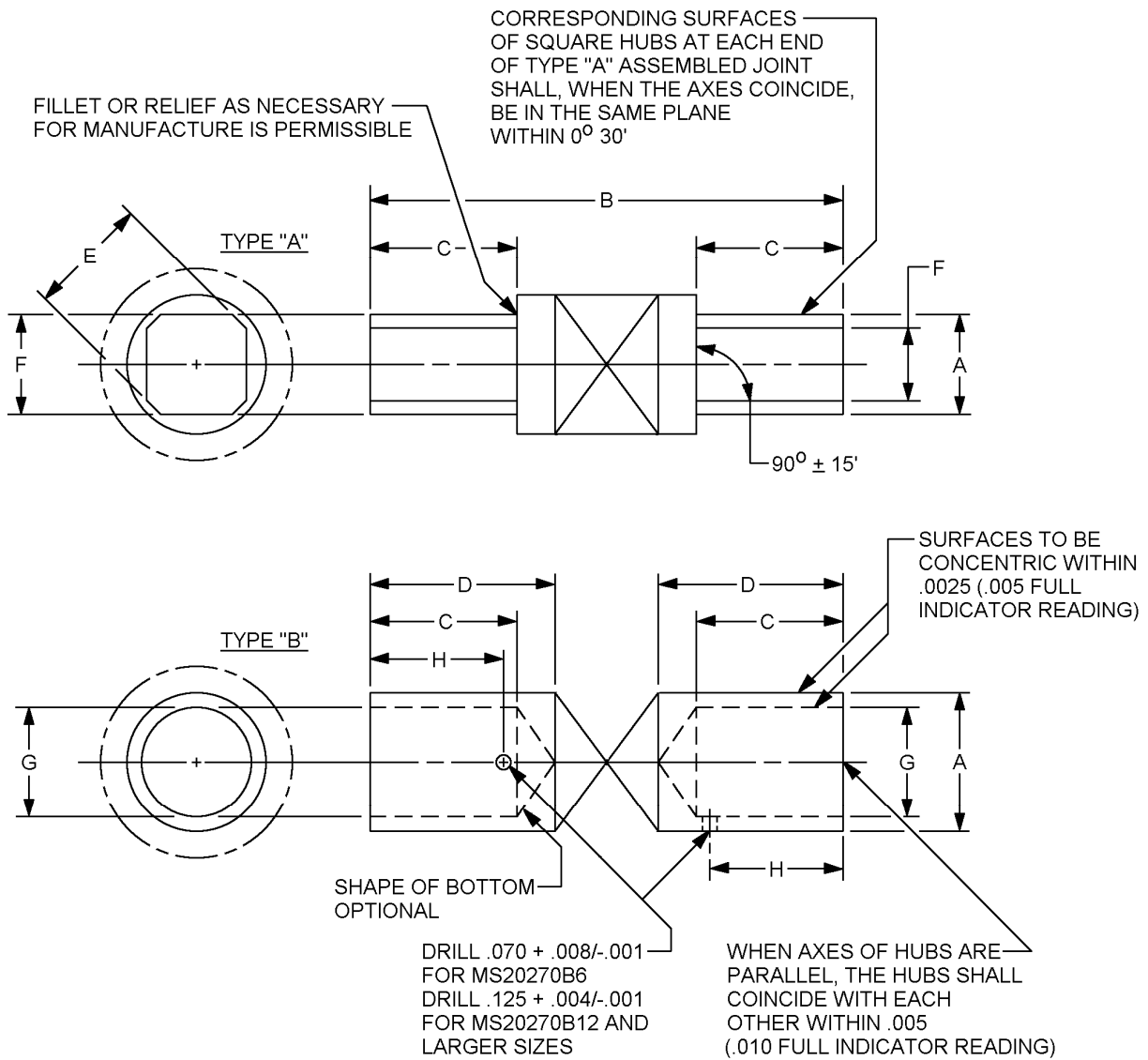

FIGURE 1. Universal joint dimensions and configurations.

MS20270D

Inches	mm
.0025	0.064
.001	0.03
.004	0.10
.005	0.13
.008	0.20
.010	0.25
.025	0.64
.070	1.78

MS PIN	MS PIN	Nominal size		A +.000 -.002 (0.05 mm) Dia		B		C +.031 (0.79 mm) -.000	
		Inches	mm	Inches	mm	Inches	mm	Inches	mm
---	MS20270B6	.375	9.53	.372	9.45	1.750	44.45	.375	9.53
MS20270A8	MS20270B8	.500	12.70	.495	12.57	1.875	47.63	.500	12.70
MS20270A10	MS20270B10	.625	15.88	.620	15.75	2.187	55.55	.625	15.88
MS20270A12	MS20270B12	.750	19.05	.745	18.93	2.500	63.50	.750	19.05
---	MS20270B14	.875	22.23	.870	22.10	3.000	76.20	.875	22.23
MS20270A16	MS20270B16	1.0000	25.40	.995	25.27	3.375	85.73	1.031	26.19
MS20270A20	MS20270B20	1.250	31.75	1.245	31.62	3.750	95.25	1.125	28.58
MS20270A24	MS20270B24	1.500	38.10	1.495	37.97	4.500	114.30	1.187	30.15

MS PIN	MS PIN	D Min		E +.000 -.005 (0.13 mm)		F +.000 -.001 (0.03 mm)		G +.004 (0.10 mm) -.001 (0.03 mm) Dia	
		Inches	mm	Inches	mm	Inches	mm	Inches	mm
---	MS20270B6	.625	15.88	---	---	---	---	.250	6.35
MS20270A8	MS20270B8	.625	15.88	.493	12.52	.373	9.53	.375	9.53
MS20270A10	MS20270B10	.750	19.05	.562	14.27	.436	11.07	.500	12.70
MS20270A12	MS20270B12	.875	22.23	.743	18.87	.560	14.22	.625	15.88
---	MS20270B14	1.031	26.19	---	---	---	---	.750	19.05
MS20270A16	MS20270B16	1.125	28.58	.875	22.23	.686	17.42	.812	20.62
MS20270A20	MS20270B20	1.187	30.15	1.187	30.15	.873	22.17	1.062	26.97
MS20270A24	MS20270B24	1.375	34.93	1.375	34.93	.998	25.35	1.250	31.75

MS PIN	MS PIN	H Min		Type B weight Max	
		Inches	mm	LB	gram
---	MS20270B6	.312	7.92	.035	15.88
MS20270A8	MS20270B8	.437	11.10	.065	29.48
MS20270A10	MS20270B10	.562	14.27	.095	43.09
MS20270A12	MS20270B12	.687	17.45	.160	72.57
---	MS20270B14	.875	22.23	.220	99.79
MS20270A16	MS20270B16	.875	22.23	.385	174.63
MS20270A20	MS20270B20	.937	23.80	.630	285.76
MS20270A24	MS20270B24	1.062	26.97	1.200	544.31

FIGURE 1. Universal joint dimensions and configurations - Continued.

MS20270D

NOTES:

1. Dimensions are in inches.
2. Metric equivalents are given for information only.
3. Tolerances unless otherwise noted are $\pm .015$ inches (0.38 mm).
4. Maximum diameter at the center of the joint shall not exceed the "A" dimensions by more than .060 inch (1.52 mm).

FIGURE 1. Universal joint dimensions and configurations - Continued.

REQUIREMENTS

Dimensions and configurations, see figure 1.

Part or Identifying Number (PIN):

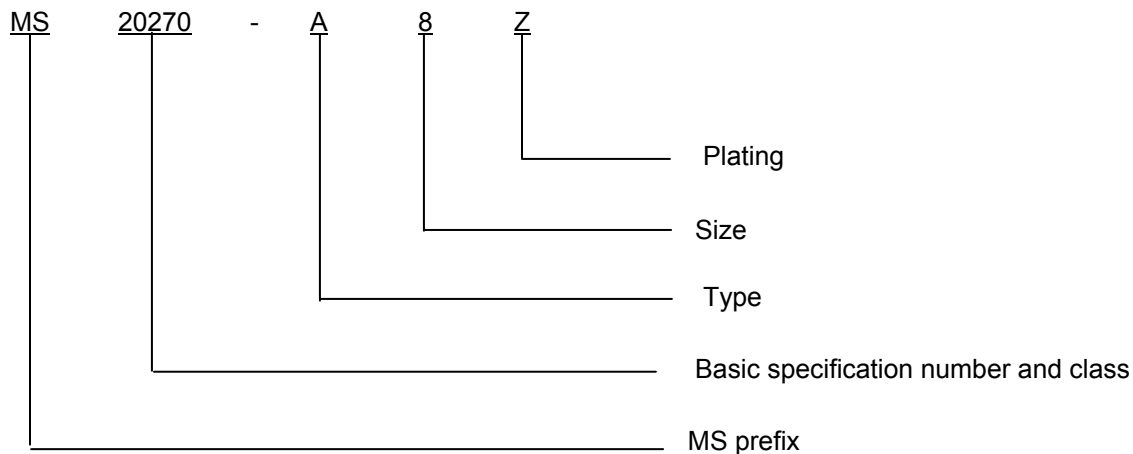

Classification. The universal joints shall be of the following class and types:

Class 1: Light duty.

Type: See table I and figure 1.

TABLE I. Type designator.

Type designator	End configuration
A	Square
B	Round

Size: See table II and figure 1.

MS20270D

TABLE II. Size designator.

Size designator		Nominal size of universal joint fraction	Nominal OD of universal joint inch	Nominal size of universal joint mm
Type A	Type B			
---	6	3/8	.375	9.53
8	8	1/2	.500	12.70
10	10	5/8	.625	15.88
12	12	3/4	.750	19.05
---	14	7/8	.875	22.23
16	16	1	1.000	25.40
20	20	1 1/4	1.250	31.75
24	24	1 1/2	1.500	38.10

Plating designator:

Blank - Cadmium
Z - Zinc

Guidance on use of alternative parts with less hazardous or non-hazardous materials. This specification provides for a number of alternative plating materials via the PIN. Users should select the PIN with the least hazardous material that meets the form, fit, and function requirements of their application.

Changes from previous issue. Marginal notations are not used in this revision to identify changes with respect to the previous issue due to the extent of the changes.

Referenced documents. This document references MIL-DTL-6193.

CONCLUDING MATERIAL

Custodians:

Army - AR
Navy - AS
Air Force - 99
DLA - CC

Preparing activity:

DLA - CC

(Project 3010-2005-004)

Review activities:

Army - CR4
Air Force - 71
DLA - GS

Industry association:

SAE - G3

NOTE: The activities listed above were interested in this document as of the date of this document. Since organizations and responsibilities can change, you should verify the currency of the information above using the ASSIST Online database at <http://assist.daps.dla.mil>.