

RESCUE HOOK ASSEMBLY

DASH NO.	RESCUE HOOK ASSEMBLY INCLUDING PARTS:
-1 (A)	AS SHOWN
-2	WITHOUT -6,-8,-9, AN960-CE16L & MS20613-3C14
-2A	AS SHOWN

~~(A) RESCUE HOOK MS18027-1 WAS PREVIOUSLY IDENTIFIED AS MS18027, INTERCHANGEABILITY WAS NOT AFFECTED BY THIS REIDENTIFICATION.~~

MS18027-1 IS NOT SUITABLE FOR USE, USE MS18027-2A (SAFETY INVOLVED)

NOTES:

- MATERIAL: (A) WASHER; DELRIN, COMMERCIAL.
(B) BUSHINGS AND NUT; CORROSION-RESISTANT STEEL, MIL-S-7720, COMPOSITION 316, CONDITION B, COLD FINISH.
(C) HOOK AND SWIVEL FITTING; CORROSION-RESISTANT STEEL, MIL-S-7720, COMPOSITION 316, CONDITION C FORGING.
(D) SPRINGS; CORROSION-RESISTANT STEEL, QQ-W-423, COMPOSITION 316, CONDITION B, SPRING TEMPER.
(E) LATCH, EQUIPMENT HOOK: CORROSION-RESISTANT STEEL, MIL-S-5059, COMPOSITION 316, 1/4 HARD.
(F) LATCH, PERSONNEL HOOK: INVESTMENT CASTING, CORROSION-RESISTING STEEL MIL-S-81591, COMPOSITION 316.
- SURFACE TEXTURE: MACHINE ALL SURFACES, AS SPECIFIED, IN ACCORDANCE WITH ANSI B46, 1-1962.
- COATING: PASSIVATE IN ACCORDANCE WITH QQ-P-35.
- BREAK ALL SHARP EDGES .031 MAXIMUM.
- DIMENSIONS IN INCHES. UNLESS OTHERWISE SPECIFIED, TOLERANCES: DECIMALS ±.010, ANGLES ±1/2°.
- DIMENSIONS & TOLERANCING SHALL BE IN ACCORDANCE WITH USASI Y14.5-1966 (ANSI).
- THREADS SHALL BE IN ACCORDANCE WITH MIL-S-8879.
- APPROXIMATE WEIGHT OF MS18027-2A IS 1½ POUNDS.

FOR DESIGN FEATURE PURPOSES, THIS STANDARD TAKES PRECEDENCE OVER PROCUREMENT DOCUMENTS REFERENCED HEREIN. REFERENCED DOCUMENTS SHALL BE OF THE ISSUE IN EFFECT ON DATE OF INVITATIONS FOR BID.

(E) DENOTES CHANGES

DISTRIBUTION STATEMENT A: APPROVED FOR PUBLIC RELEASE. DISTRIBUTION IS UNLIMITED. This military standard is approved by NAVAL AIR SYSTEMS COMMAND, Department of the Navy and shall be used by that activity. All other military activities are required to employ this standard where applicable.

P.A. NAVY - AS Other Cust	TITLE HOOK, HELICOPTER RESCUE	MILITARY STANDARD MS18027(AS)
PROCUREMENT SPECIFICATION MIL-H-23599(AS)	SUPERSEDES: ACEL 5-952	SHEET 1 OF 6

APPROVED 7 Jan 1963 REVISED 6 OCT 1965 3 Oct 1966 2 APR 1971 15 DEC 1976 10 SEP 85

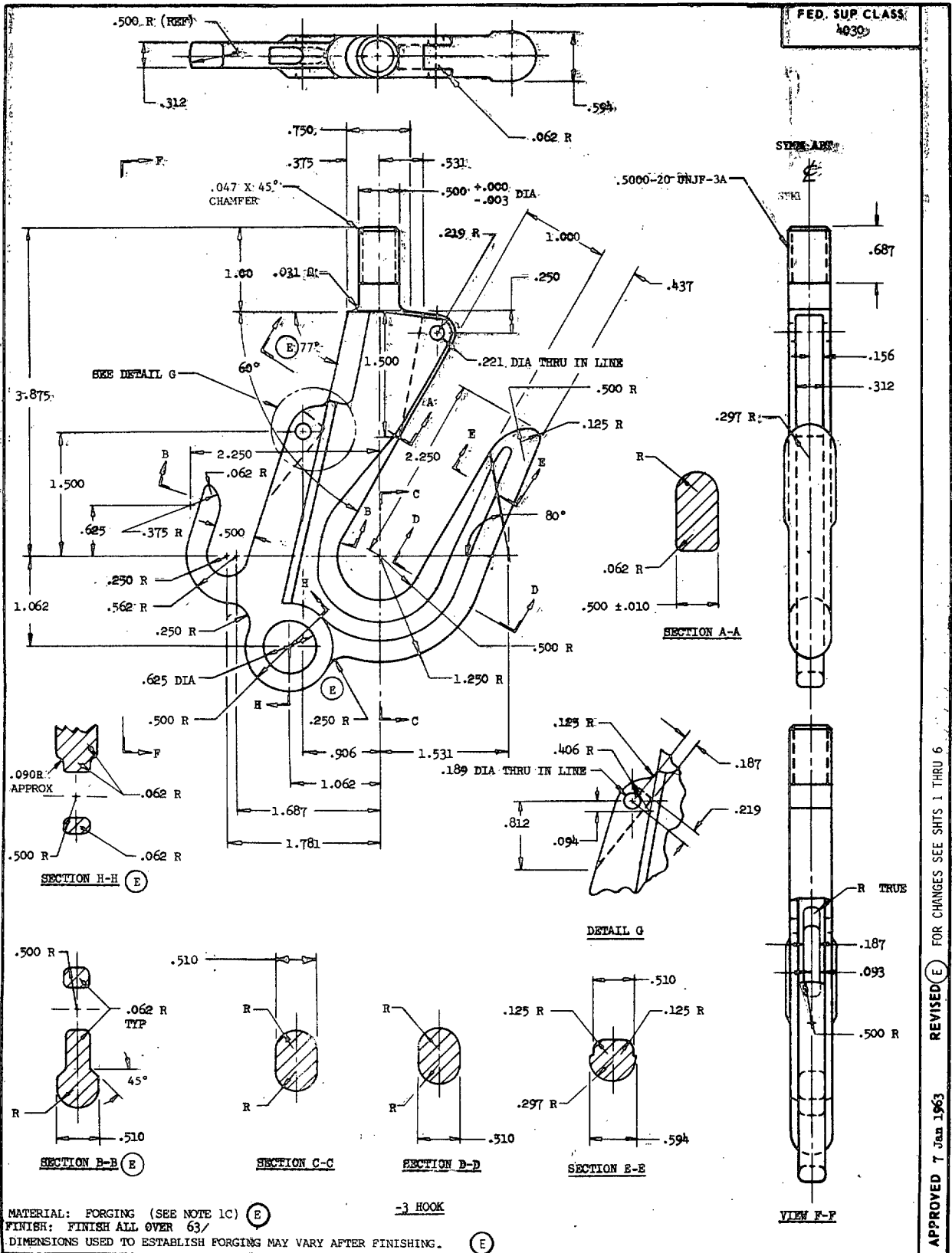

FED. SUP. CLASS. 4830

This military standard is approved by NAVAL AIR SYSTEMS COMMAND, Department of the Navy and shall be used by that activity. All other military activities are required to employ this standard where suitable.

APPROVED 7 Jan 1963 REVISED (E) FOR CHANGES SEE SHITS 1 THRU 6

MATERIAL: FORGING (SEE NOTE 1C) (E)
 FINISH: FINISH ALL OVER 63/
 DIMENSIONS USED TO ESTABLISH FORGING MAY VARY AFTER FINISHING. (E)

P. A. NAVY - AS Other Cust (E)	TITLE HOOK, HELICOPTER RESCUE	MILITARY STANDARD
		MS18027(AS)
PROCUREMENT SPECIFICATION MIL-H-23599(AS)	SUPERSEDES: ACEL 5-952	SHEET 2 of 6

FED. SUP CLASS
A090

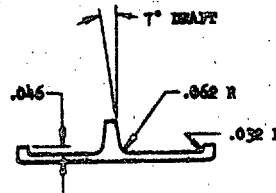
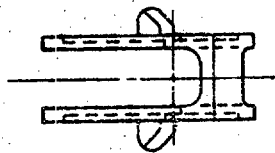

SECTION I-I

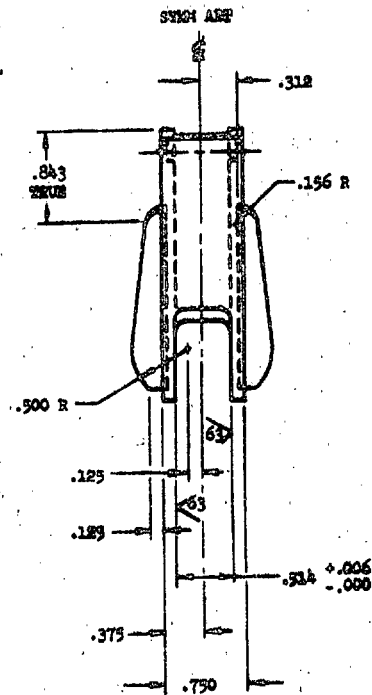
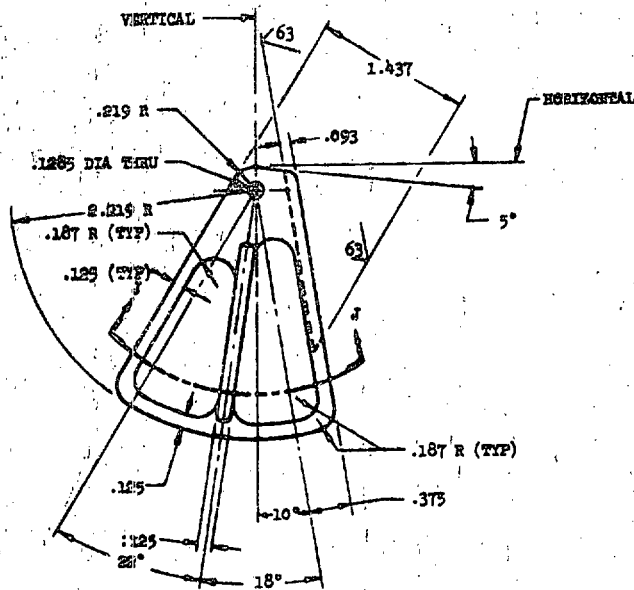

4. LATCH, PERSONNEL HOOK

(E)

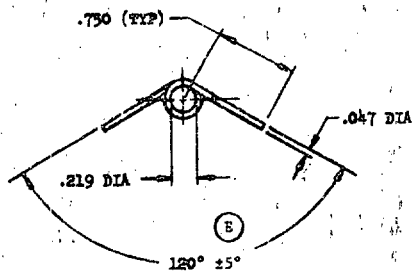

5. SPRING, PERSONNEL HOOK LATCH



TOTAL NO. OF COILS 2-1/6

This military standard is approved by NAVAL AIR SYSTEMS COMMAND, Department of the Navy and shall be used by that activity. All other military activities are required to employ this standard where suitable.

P.A. NAVY - AS Other Cust (E)	TITLE	MILITARY STANDARD
	HOOK, HELICOPTER RESCUE	MS18027(AS)
PROCUREMENT SPECIFICATION MIL-R-23999(AS)	SUPERSEDES: ACEL 5-992	SHEET 3 OF 6

APPROVED 7 Feb 1963 REVISED (E) FOR CHANGES SEE SHTS 1 THRU 6

FED. SUP-CLASS
4030

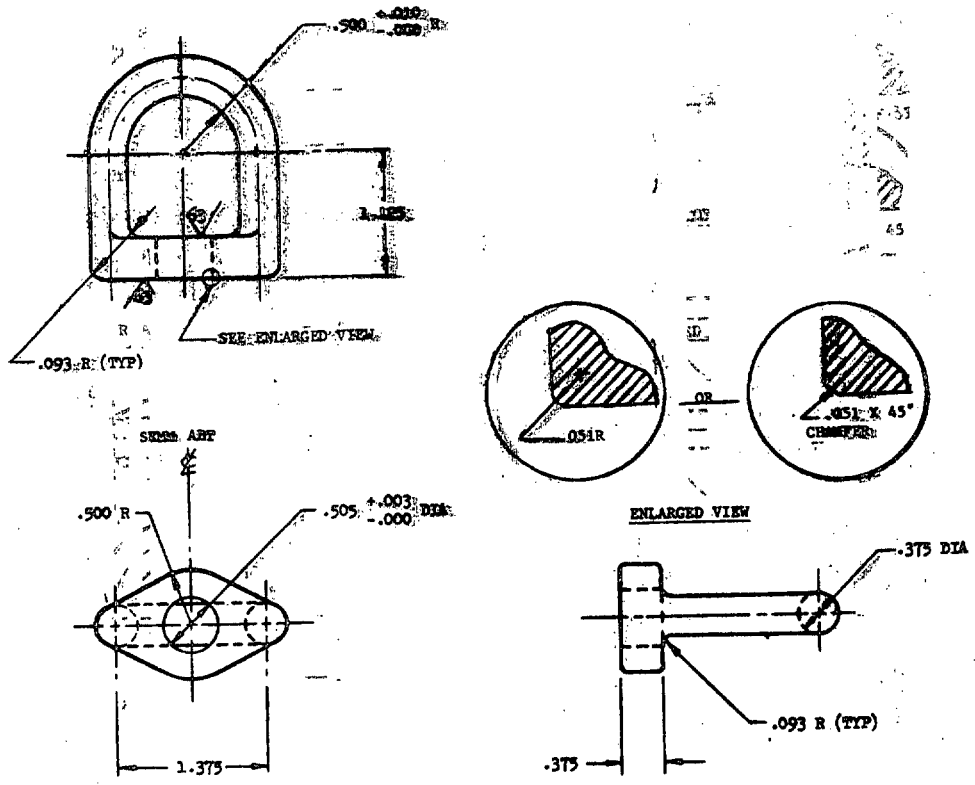

-6. SNIVEL FITTING

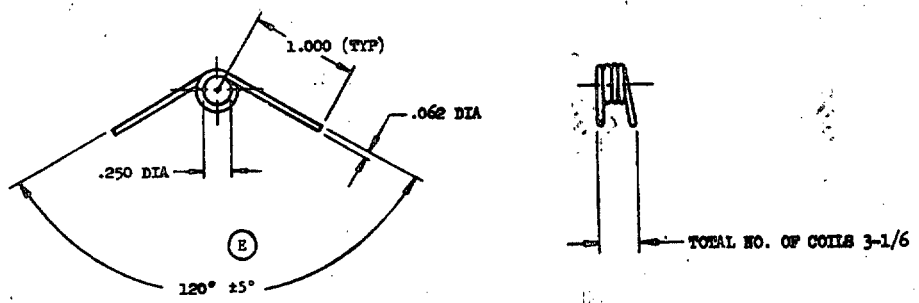

-7. SPRING, EMBOWED HOOK LATCH

This military standard is approved by NAVAL AIR SYSTEMS COMMAND, Department of the Navy and should be used by that activity. All other military activities are required to employ this standard where suitable.

APPROVED 7 Jan 1963 REVISED (E) FOR CHANGES SEE SHITS 1 THRU 6

P.A. NAVY - 129 Other Cost (E)	TITLE	MILITARY STANDARD
	HOOK, HELICOPTER RESCUE	MS18027(AS)
PROCUREMENT SPECIFICATION MIL-H-23599(AS)	SUPERSEDES: ACHL 5-952	SHEET 4 of 6

FED. SUP CLASS
4030

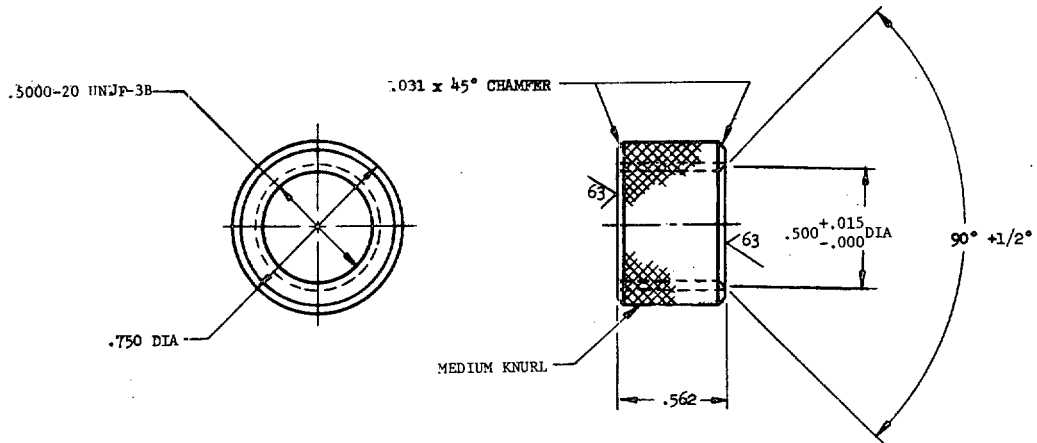

-8, KNURLED NUT

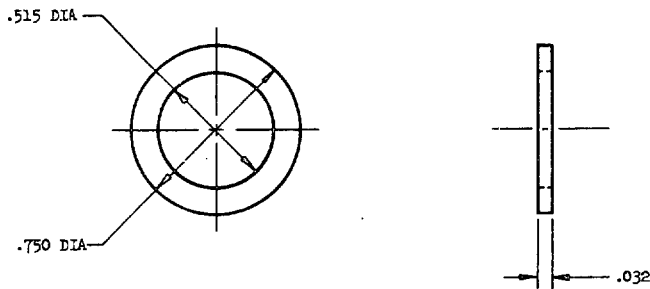

-9, WASHER

This military standard is approved by NAVAL AIR SYSTEMS COMMAND, Department of the Navy and shall be used by that activity. All other military activities are required to employ this standard where applicable.

APPROVED 7 Jan 1963 REVISED (E) FOR CHANGES SEE SHTS 1 THRU 6

P.A. NAVY - AS Other Cust (E)	TITLE HOOK, HELICOPTER RESCUE	MILITARY STANDARD MS 18027(AS)
PROCUREMENT SPECIFICATION MIL-H-23599(AS)	SUPERSEDES: ACEL 5-952	SHEET 5 of 6

FED. SUP. CLASS
18030

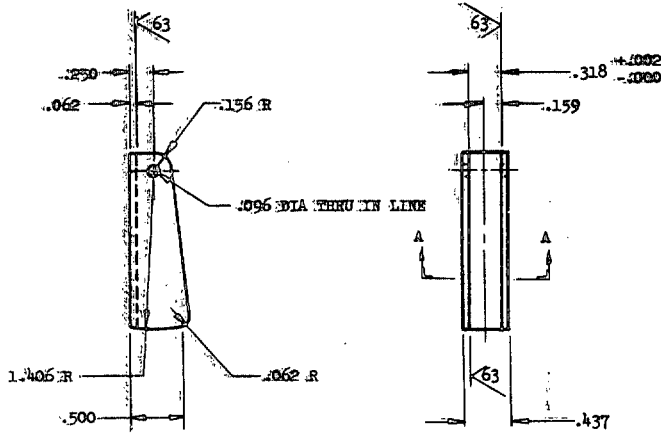

-10. LATCH EQUIPMENT HOOK

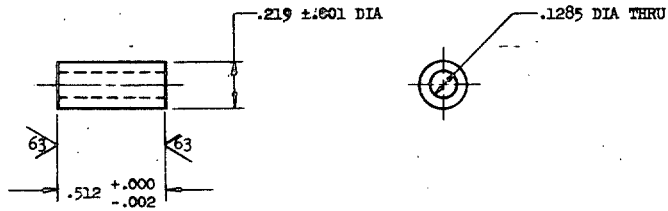

-11, BUSHING

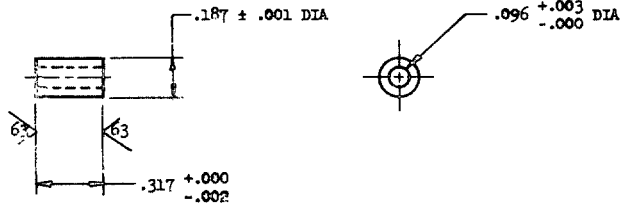

-12, BUSHING

This military standard is approved by NAVAL AIR SYSTEMS COMMAND, Department of the Navy and shall be used by that activity. All other military activities are required to employ this standard where suitable.

APPROVED 7 Jan 1963 REVISED (E) FOR CHANGES SEE SHTS 1 THRU 6

P.A. NAVY - AS Other Cust (E)	TITLE HOOK, HELICOPTER RESCUE	MILITARY STANDARD
		MS18027(AS)
PROCUREMENT SPECIFICATION MIL-R-23599(AS)	SUPERSEDES: ACEL 5-952	SHEET 6 of 6