

INCH-POUND

MS16631F
 18 September 2014
 SUPERSEDING
 MS16631E
 14 March 2012

DETAIL SPECIFICATION SHEET

RING, RETAINING, INTERNAL, BEVELED
 (TAPERED SECTION TYPE)

This specification is approved for use by all Departments and Agencies of the Department of Defense.

The requirements for acquiring the product described herein shall consist of this specification sheet and procurement specification MIL-R-21248.

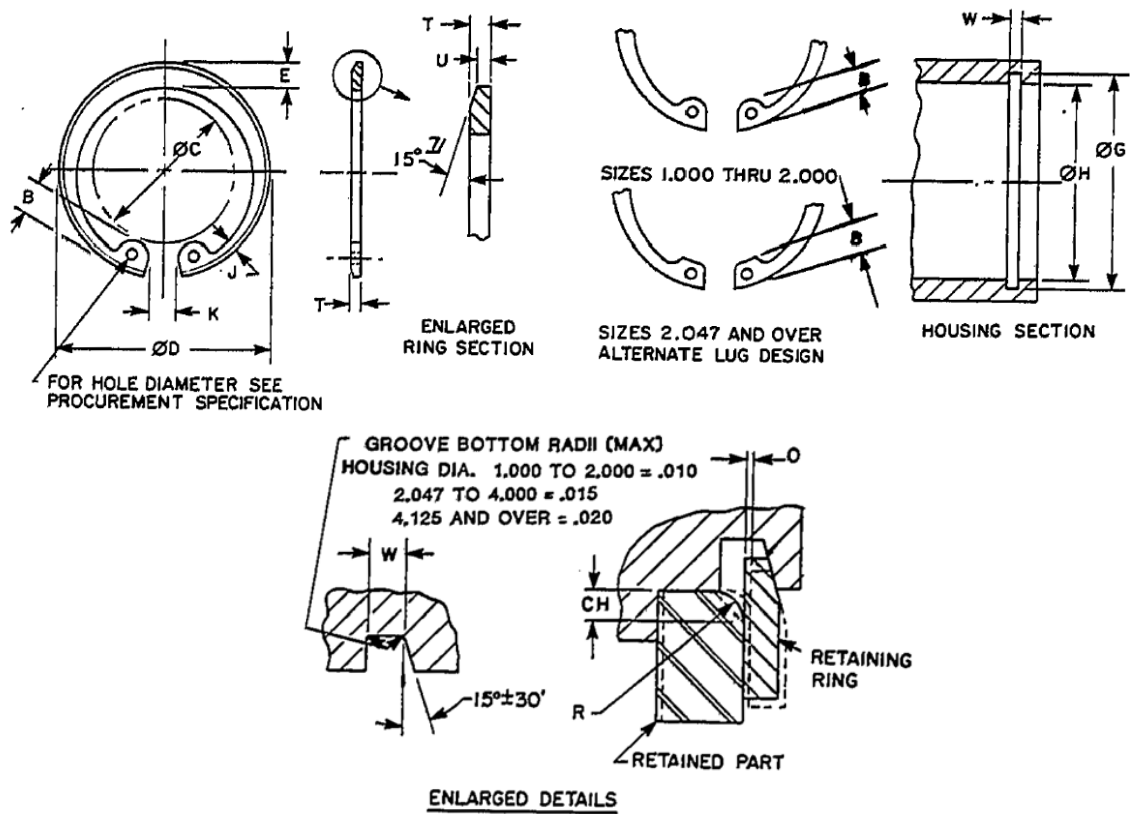

FIGURE 1. RING, RETAINING.

TABLE I. DIMENSIONS.

ØH HOUSING (REF)	ØD FREE		B LUG HEIGHT		E LARGE SECTION HEIGHT		J SMALL SECTION HEIGHT		U Z/ THICKNESS AT BEVELED EDGE		T 1/ THICKNESS		ØG		W WIDTH		K 3/ GAP WIDTH	ØC 4/ CLEAR	O 5/ TAKE UP	R 6/	CH 6/ OF RETAINED PART (REF)
	BASIC	TOL	BASIC	TOL	BASIC	TOL	BASIC	TOL	BASIC	TOL	BASIC	TOL	BASIC	TOL	BASIC	TOL					
1.000	25.4	1.111	+0.015	.155	.104	±.005	.052	±.005	.033		.042		1.076	+0.005	.036		.145	.665	.005	.042	.034
1.023	26.0	1.136	-0.010	.155	.106		.054		.033		.042		1.101	-0.000	.036		.150	.69	.005	.042	.034
1.062	27.0	1.180		.180	.110		.055		.041		.050		1.138		.044		.143	.685	.005	.044	.035
1.125	28.6	1.249		.180	.116		.057		.040		.050		1.205		.043		.157	.745	.005	.047	.036
1.181	30.0	1.319		.180	.120		.058		.040		.050		1.265		.043		.150	.79	.0055	.047	.036
1.188	30.2	1.319		.180	.120		.058		.040		.050	±.002	1.272		.043		.169	.80	.0055	.047	.036
1.250	31.7	1.388	+0.025	.180	.124		.062		.039		.050		1.342	+0.006	.042		.184	.875	.006	.048	.038
1.259	32.0	1.388	-0.020	.180	.124	±.006	.062	±.006	.039		.050		1.351	-0.000	.042		.209	.885	.006	.048	.038
1.312	33.3	1.456		.180	.130		.063		.039		.050		1.408	.005	.042	+0.005	.198	.93	.006	.048	.038
1.375	34.9	1.526		.180	.130		.063		.038		.050		1.475		.041	-0.000	.211	.99	.0065	.048	.038
1.378	35.0	1.526		.180	.130		.063		.038		.050		1.478		.041		.219	.99	.0065	.048	.038
1.438	36.5	1.596		.180	.133		.065		.037	±.001	.050		1.542		.040		.221	1.06	.007	.048	.038
1.456	37.0	1.616		.180	.133		.065		.037		.050		1.562		.040		.226	1.08	.007	.048	.038
1.500	38.1	1.660		.180	.133		.066		.037		.050		1.604		.040		.238	1.12	.007	.048	.038
1.592	39.7	1.734		.220	.157		.078		.048		.062		1.674		.052		.238	1.10	.0075	.064	.050
1.575	40.0	1.734		.220	.157		.078		.048		.062		1.687		.052		.275	1.12	.0075	.064	.050
1.625	41.3	1.804		.220	.164		.082		.047		.062		1.743		.051		.242	1.15	.008	.084	.050
1.653	42.0	1.835		.227	.167		.083		.047		.062		1.773		.051		.248	1.17	.008	.084	.050
1.688	42.9	1.874		.220	.170		.085		.046		.062		1.810	+0.007	.050		.255	1.21	.008	.084	.050
1.750	44.4	1.942	+0.035	.240	.171		.083		.046		.062		1.878	.005	.050		.267	1.26	.0085	.064	.050
1.812	46.0	2.012	-0.025	.240	.170	±.005	.084		.046		.062		1.944		.050		.250	1.32	.009	.064	.050
1.850	47.0	2.054		.240	.170		.085		.046		.062		1.984		.050		.284	1.36	.009	.064	.050
1.875	47.6	2.054		.240	.170		.085		.046		.062		2.011		.050		.320	1.39	.009	.064	.050
1.938	49.2	2.141		.240	.170		.085		.045		.062		2.082		.049		.328	1.45	.0095	.064	.050
2.000	50.8	2.210		.240	.170		.085		.044		.062		2.144		.048		.332	1.50	.0095	.064	.050
2.047	52.0	2.280		.250	.186		.091		.060		.078		2.195		.065		.311	1.52	.0095	.078	.061
2.062	52.4	2.280		.250	.186		.091		.060		.078		2.210	+0.007	.065		.349	1.54	.0095	.078	.062
2.125	54.0	2.350	+0.040	.260	.195		.096		.060		.078		2.279	-0.000	.065	+0.007	.345	1.58	.010	.078	.062
2.165	55.0	2.415	-0.030	.264	.199	±.007	.098	±.007	.059		.078		2.327	.006	.064	-0.000	.323	1.61	.010	.078	.062
2.188	55.6	2.415		.264	.199		.098		.059		.078	±.003	2.350		.064		.373	1.64	.010	.078	.062
2.250	57.1	2.490		.270	.203		.099		.059	±.0015	.078		2.420		.064		.368	1.69	.0105	.078	.062

TABLE I. DIMENSIONS - CONTINUED

ØH HOUSING (REF)		ØD FREE		B LUG HEIGHT		E LARGE SECTION HEIGHT		J SMALL SECTION HEIGHT		U Z/ THICKNESS AT BEVELED EDGE		T 1/ THICKNESS		ØG RECOMMENDED GROOVE (REF)		W WIDTH		K 3/ GAP WIDTH	ØC 4/ CLEAR	O 5/ TAKE UP	R 6/	CH 6/ OF RETAINED PART (REF)
INCH	MM	BASIC	TOL	BASIC	TOL	BASIC	TOL	BASIC	TOL	BASIC	TOL	BASIC	TOL	BASIC	TOL	BASIC	TOL	MIN	MAX	MAX	MAX	
2.312	58.7	2.535		.270		.205		.100		.058		.078		2.484	+0.007	.063		.415	1.75	.011	.078	.062
2.375	60.3	2.630		.270		.207		.102		.058		.078		2.552	-0.000	.063		.374	1.81	.0115	.078	.062
2.440	62.0	2.702		.280		.209		.103		.057	±0.0015	.078		2.618	.006	.062		.386	1.86	.012	.078	.062
2.500	63.5	2.775		.280		.210		.103		.057		.078		2.684	FIM 2/	.062		.398	1.91	.012	.078	.062
2.531	64.3	2.775	+0.040	.280		.210		.103		.057		.078		2.717		.062	+0.007	.460	1.94	.0125	.078	.062
2.562	65.1	2.844	-0.030	.290		.222		.109		.072		.093		2.750		.078	-0.000	.400	1.95	.0125	.088	.070
2.625	66.7	2.910		.290		.226		.111		.071		.093		2.820		.077		.418	2.02	.013	.088	.070
2.677	68.0	2.980		.300	±0.005	.230	±0.007	.113	±0.007	.071		.093		2.876		.077		.393	2.05	.013	.090	.072
2.688	68.3	2.980		.300		.230		.113		.071		.093		2.887		.077		.423	2.06	.013	.090	.072
2.750	69.8	3.050		.300		.234		.115		.070		.093		2.955		.076		.442	2.12	.014	.092	.074
2.812	71.4	3.121		.300		.230		.115		.070	±0.002	.093		3.020		.076		.459	2.18	.014	.088	.070
2.835	72.0	3.121		.300		.230		.115		.070		.093		3.043		.076		.512	2.21	.014	.088	.070
2.875	73.0	3.191		.310		.240		.120		.070		.093		3.065		.076		.451	2.22	.014	.092	.074
2.953	75.0	3.325		.310		.250		.122		.068		.093		3.178		.074		.449	2.30	.015	.092	.074
3.000	76.2	3.325		.310		.250		.122		.068		.093		3.225		.074		.568	2.35	.015	.092	.074
3.062	77.8	3.418		.310		.254		.126		.082		.109		3.290		.069		.473	2.41	.015	.097	.078
3.125	79.4	3.488		.310		.259		.129		.082		.109		3.355		.089		.469	2.47	.0155	.099	.079
3.149	80.0	3.523		.310		.262		.129		.082		.109		3.381		.089		.462	2.49	.0155	.100	.080
3.156	80.2	3.523		.310		.262		.129		.082		.109		3.388		.089		.481	2.50	.0155	.100	.080
3.250	82.5	3.623		.342		.269		.135		.082		.109		3.489		.089		.509	2.54	.016	.104	.083
3.346	85.0	3.734	±0.055	.342		.276		.140		.082		.109		3.591		.089		.514	2.63	.0165	.180	.086
3.469	88.1	3.857		.342		.286		.144		.082		.109		3.726		.089		.571	2.76	.017	.108	.086
3.500	88.9	3.890		.342		.289		.142	±0.008	.082	±0.008	.109		3.760		.089		.574	2.79	.017	.110	.088
3.543	90.0	3.936		.342		.292		.142		.082		.109		3.606		.089		.586	2.83	.0175	.110	.088
3.562	90.5	3.936		.342		.292		.142		.082		.109		3.830		.089		.643	2.85	.018	.110	.088
3.625	92.1	4.024		.342		.299		.150		.082		.109		3.900	+0.010	.089		.639	2.91	.018	.116	.093
3.740	95.0	4.157		.342		.309		.155		.082		.109	±0.003	4.030	-0.000	.089		.647	3.02	.0195	.120	.096
3.750	95.2	4.157		.342	±0.008	.309		.155		.082		.109		4.040	.006	.089	+0.008	.674	3.03	.0195	.120	.096
3.875	98.4	4.291		.370		.319		.160		.082		.109		4.171	FIM 2/	.089	-0.000	.680	3.11	.020	.123	.098
3.938	100.0	4.358		.370		.324		.161		.082		.109		4.236		.089		.687	3.17	.020	.124	.099
4.000	101.6	4.424		.370		.330		.166		.082		.109		4.302		.089		.694	3.23	.020	.128	.102
4.125	104.8	4.558		.370		.330		.171		.082		.109		4.433		.089		.718	3.36	.021	.130	.104
4.250	108.0	4.691		.370		.335		.180		.082	±0.0025	.109		4.562		.089		.743	3.48	.021	.138	.110
4.331	110.0	4.756		.405		.343		.180		.082		.109		4.647		.089		.803	3.50	.021	.142	.114
4.500	114.3	4.940		.405		.351		.181		.082		.109		4.824		.089		.787	3.66	.022	.146	.117
4.625	117.5	5.076	±0.065	.405		.360		.183		.082		.109		4.955		.089		.822	3.79	.022	.151	.121
4.724	120.0	5.213		.405		.370		.183		.082		.109		5.060		.089		.773	3.88	.023	.154	.123
4.750	120.6	5.213		.405		.370		.183	±0.009	.082		.109		5.086		.089		.843	3.90	.023	.154	.123
5.000	127.0	5.485		.435		.390		.186		.082	±0.009	.125		5.346		.089		.753	4.08	.023	.158	.126
5.250	133.3	5.770		.455		.408		.198		.095		.125		5.612		.102		.886	4.31	.024	.168	.134
5.375	136.5	5.910		.455	±0.010	.408		.198		.095		.125	±0.004	5.739	+0.012	.102	+0.010	.893	4.41	.024	.168	.134
5.500	139.7	6.066		.455		.408		.198		.095		.125		5.864	-0.000	.102	-0.000	.879	4.53	.024	.168	.134
5.750	146.0	6.336		.455		.408		.198		.095	±0.003	.125		6.120	.006	.102		.905	4.78	.025	.168	.134
6.000	152.4	6.620		.455		.408		.196		.095		.125		6.374	FIM 2/	.102		.929	5.03	.025	.168	.134

3

MS1631F

TABLE I. DIMENSIONS. - CONTINUED

ØH HOUSING (REF)		ØD FREE		B LUG HEIGHT		E LARGE SECTION HEIGHT		J SMALL SECTION HEIGHT		U ^{1/} THICKNESS AT BEVELED EDGE		T ^{1/} THICKNESS		ØG RECOMMENDED GROOVE (REF)		W WIDTH		K ^{3/} GAP WIDTH	ØC ^{4/} CLEAR	O ^{5/} TAKE UP	R ^{6/}	CH ^{6/}
INCH	MM	BASIC	TOL	BASIC	TOL	BASIC	TOL	BASIC	TOL	BASIC	TOL	BASIC	TOL	BASIC	TOL	BASIC	TOL	MIN	MAX	MAX	MAX	MAX
6.250	158.7	6.895		.485		.432		.211		.121		.156		6.642		.129		.956	5.24	.026	.177	.142
6.500	165.1	7.170		.485		.438		.219		.121		.156		6.908		.129		1.040	5.49	.027	.181	.145
6.625	168.3	7.308	±.080	.485		.447		.221	±.009	.121		.156		7.042		.129		1.063	5.60	.028	.183	.146
6.750	171.4	7.445		.530		.456		.224		.120		.156		7.174		.128		.985	5.65	.028	.188	.150
7.000	177.8	7.720		.530		.474		.232		.120		.156		7.441		.128		1.037	5.88	.029	.196	.157
7.250	184.1	7.995		.560		.489		.238		.150		.187		7.708		.159		1.085	6.08	.031	.202	.162
7.500	190.5	8.270		.560		.507		.247		.150	±.003	.187		7.974		.159	+0.015	1.138	6.33	.032	.208	.166
7.750	196.8	8.545		.560	±.010	.523		.255		.150		.187		8.240		.159	-0.000	1.178	6.58	.033	.214	.171
8.000	203.2	8.820		.600		.540		.262		.146		.187		8.507		.155	.006	1.238	6.75	.034	.220	.176
8.250	209.5	9.095		.600		.558		.270		.146		.187		8.773		.155	FIM ^{2/}	1.269	7.00	.035	.229	.183
8.500	215.9	9.285		.660		.573		.277		.142		.187		9.040		.151		1.444	7.13	.036	.235	.188
8.750	222.2	9.558	±.090	.660		.591	±.010	.286		.142		.187		9.307		.151		1.481	7.38	.037	.241	.193
9.000	228.6	9.830		.660		.609		.294		.142		.187		9.573		.151		1.539	7.63	.038	.249	.199
9.250	235.0	10.102		.660		.625		.299		.142		.187		9.838		.151		1.559	7.88	.039	.253	.202
9.500	241.3	10.375		.735		.642		.304		.138		.187		10.106		.147		1.596	7.98	.041	.258	.206
9.750	247.7	10.648		.735		.658		.309		.138		.187		10.372		.147		1.680	8.23	.042	.263	.210
10.000	254.0	10.920		.735		.675		.315		.138		.187		10.639		.147		1.687	8.48	.043	.270	.216

1/ T - THICKNESS "T" APPLIES TO UNPLATED RINGS. FOR CORROSION RESISTANT STEEL AND PLATED RINGS, +.002 SHOULD BE ADDED TO THE MAXIMUM TOLERANCE, i.e. ±.002 SHOULD BE +.004/-.002.
 2/ FIM - (FULL INDICATOR MOVEMENT) IS THE MAXIMUM ALLOWABLE DEVIATION OF CONCENTRICITY BETWEEN THE GROOVE AND THE HOUSING.
 3/ K - MINIMUM GAP WIDTH WHEN THE RING IS PROPERLY SEATED IN THE GROOVE (DESIGN REFERENCE DIMENSION).
 4/ C - ACTUAL CLEARANCE DIAMETER WHEN THE RING IS SPRUNG INTO THE HOUSING, PRIOR TO INSTALLATION INTO THE GROOVE. (DESIGN REFERENCE DIMENSION).
 5/ O - END PLAY TAKE UP.
 6/ R AND CH - RADIUS OR CHAMFERS ALLOWABLE ON PARTS TO BE RETAINED BY THE RINGS. THRUST LOADS OF RINGS, RETAINING PARTS WITH CORNER RADII OR CHAMFERS ARE TABULATED ON PAGE 10
 7/ 15 AND U - THESE DIMENSIONS ARE FOR GROOVE LOCATION CALCULATIONS ONLY (SEE (F) ON PAGE 9) AND NOT FOR INSPECTION PURPOSES.

MS16631F

REQUIREMENTS:

1. CLASSIFICATION: RETAINING RINGS FURNISHED UNDER THIS STANDARD SHALL BE TYPE III, CLASS 1 OF THE PROCUREMENT SPECIFICATION.
2. MATERIAL:
 - (a) CARBON SPRING STEEL, GRADE 1060 THRU 1095 (UNS G10600 THRU G10950) IN ACCORDANCE WITH ASTM A568/A568M OR ASTM A684/A684M.
 - (b) CORROSION RESISTANT STEEL IN ACCORDANCE WITH AMS 5520 (UNS S15700).
 - (c) BERYLLIUM COPPER, ALLOY NUMBER 170 (UNS C17000) OR ALLOY NUMBER 172 (UNS C17200) IN ACCORDANCE WITH ASTM B194.
3. HARDNESS

TABLE II. HARDNESS.

Ø HOUSING (REF)	CARBON STEEL	CORROSION RESISTANT STEEL	BERYLLIUM COPPER
1.000 TO 1.500 INCL	52.5-58.6 HR45N <u>1/</u> (48-53 HRC EQUIV)	50.3-56.1 HR45N <u>1/</u> (46-51 HRC EQUIV)	41.9-46.7 HR45N <u>1/</u> (39-43 HRC EQUIV)
1.562 TO 2.000 INCL	46-51 HRC	46-51 HRC	39-43 HRC
2.047 TO 3.000 INCL	46-51 HRC	46-51 HRC	--
3.062 AND OVER	44-49 HRC	46-51 HRC	--

1/ USE HUGHEST SCALE TO PROVIDE SECTION WIDTH EQUAL TO OR GREATER THAN 5 TIMES THE BRAILE IMPRESSION DIAMETER.

4. PROTECTIVE FINISH OR TREATMENT:

- (a) CARBON STEEL – SHALL BE AS SPECIFIED (SEE TABLE III OR IV):
 - (1) CADMIUM PLATE IN ACCORDANCE WITH SAE AMS-QQ-P-416, TYPE II, CLASS 3 OR ASTM B696, TYPE II, CLASS 5.
 - (2) ZINC COAT IN ACCORDANCE WITH ASTM B633, TYPE II, CLASS Fe/Zn5 OR ASTM B695, TYPE II, CLASS 5.
 - (3) PHOSPHATE COAT IN ACCORDANCE WITH MIL-DTL-16232, TYPE Z, CLASS 2.
- (b) CORROSION RESISTANT STEEL – SHALL BE CLEANED, DESCALED AND PASSIVATED IN ACCORDANCE WITH SAE AMS2700.

5. PART NUMBER: THE BASIC MS PART NUMBER IS FOLLOWED BY A DASH NUMBER TAKEN FROM TABLE III AND IV.

EXAMPLE: MS16631-1100 IS THE PART NUMBER FOR A CARBON STEEL, CADMIUM PLATED, INTERNAL, BEVELED RETAINING RING FOR USE IN A 1.000 DIAMETER HOUSING.

MS16631F

TABLE III. DASH NUMBERS FOR MS16631.

ØH HOUS- ING (REF)	<u>1/</u>	<u>1/</u>	<u>1/</u>	STEEL CORROSION RESISTANT	<u>1/</u>	ØH HOUS- ING (REF)	<u>1/</u>	<u>1/</u>	<u>1/</u>	STEEL CORROSION RESISTANT
	CARBON STEEL CADMIUM PLATE	CARBON STEEL ZINC COAT	CARBON STEEL PHOSPHATE COAT		BERYLLIUM COPPER		CARBON STEEL CADMIUM PLATED	CARBON STEEL Z NC COAT	CARBON STEEL PHOSPHATE COAT	
	DASH NO.	DASH NO.	DASH NO.	DASH NO.	DASH NO.		DASH NO.	DASH NO.	DASH NO.	DASH NO.
1.000	-1100	-2100	-3100	-4100	-5100	3 062	-1306	-2306	-3306	-4306
1.023	-1102	-2102	-3102	-4102	-5102	3.125	-1312	-2312	-3312	-4312
1.062	-1106	-2106	-3106	-4106	-5106	3.149	-1315 <u>2/</u>	-2315 <u>2/</u>	-3315 <u>2/</u>	-4315 <u>2/</u>
1.125	-1112	-2112	-3112	-4112	-5112	3.156	-1315 <u>2/</u>	-2315 <u>2/</u>	-3315 <u>2/</u>	-4315 <u>2/</u>
1.181	-1118 <u>2/</u>	-2118 <u>2/</u>	-3118 <u>2/</u>	-4118 <u>2/</u>	-5118 <u>2/</u>	3 250	-1325	-2325	-3325	-4325
1.188	-1118 <u>2/</u>	-2118 <u>2/</u>	-3118 <u>2/</u>	-4118 <u>2/</u>	-5118 <u>2/</u>	3 346	-1334	-2334	-3334	-4334
1.250	-1125 <u>2/</u>	-2125 <u>2/</u>	-3125 <u>2/</u>	-4125 <u>2/</u>	-5125 <u>2/</u>	3.469	-1346	-2346	-3346	-4346
1.259	-1125 <u>2/</u>	-2125 <u>2/</u>	-3125 <u>2/</u>	-4125 <u>2/</u>	-5125 <u>2/</u>	3 500	-1350	-2350	-3350	-4350
1.312	-1131	-2131	-3131	-4131	-5131	3 543	-1354 <u>2/</u>	-2354 <u>2/</u>	-3354 <u>2/</u>	-4354 <u>2/</u>
1.375	-1137 <u>2/</u>	-2137 <u>2/</u>	-3137 <u>2/</u>	-4137 <u>2/</u>	-5137 <u>2/</u>	3 562	-1354 <u>2/</u>	-2354 <u>2/</u>	-3354 <u>2/</u>	-4354 <u>2/</u>
1.378	-1137 <u>2/</u>	-2137 <u>2/</u>	-3137 <u>2/</u>	-4137 <u>2/</u>	-5137 <u>2/</u>	3 625	-1362	-2362	-3362	-4362
1.438	-1143	-2143	-3143	-4143	-5143	3.740	-1375 <u>2/</u>	-2375 <u>2/</u>	-3375 <u>2/</u>	-4375 <u>2/</u>
1.456	-1145	-2145	-3145	-4145	-5145	3.750	-1375 <u>2/</u>	-2375 <u>2/</u>	-3375 <u>2/</u>	-4375 <u>2/</u>
1.500	-1150	-2150	-3150	-4150	-5150	3 875	-1387	-2387	-3387	-4387
1.562	-1156 <u>2/</u>	-2156 <u>2/</u>	-3156 <u>2/</u>	-4156 <u>2/</u>	-5156 <u>2/</u>	3 938	-1393	-2393	-3393	-4393
1.575	-1156 <u>2/</u>	-2156 <u>2/</u>	-3156 <u>2/</u>	-4156 <u>2/</u>	-5156 <u>2/</u>	4 000	-1400	-2400	-3400	-4400
1.625	-1162	-2162	-3162	-4162	-5162	4.125	-1412	-2412	-3412	-4412
1.653	-1165	-2165	-3165	-4165	-5165	4 250	-1425	-2425	-3425	-4425
1.688	-1168	-2168	-3168	-4168	-5168	4 330	-1433	-2433	-3433	-4433
1.750	-1175	-2175	-3175	-4175	-5175	4 500	-1450	-2450	-3450	-4450
1.812	-1181	-2181	-3181	-4181	-5181	4 625	-1462	-2462	-3462	-4462
1.850	-1185 <u>2/</u>	-2185 <u>2/</u>	-3185 <u>2/</u>	-4185 <u>2/</u>	-5185 <u>2/</u>	4.724	-1475 <u>2/</u>	-2475 <u>2/</u>	-3475 <u>2/</u>	-4475 <u>2/</u>
1.875	-1185 <u>2/</u>	-2185 <u>2/</u>	-3185 <u>2/</u>	-4185 <u>2/</u>	-5185 <u>2/</u>	4.750	-1475 <u>2/</u>	-2475 <u>2/</u>	-3475 <u>2/</u>	-4475 <u>2/</u>
1.938	-1193	-2193	-3193	-4193	-5193	5 000	-1500	-2500	-3500	-4500
2.000	-1200	-2200	-3200	-4200	-5200	5 250	-1525	-2525	-3525	-4525
2.047	-1206 <u>2/</u>	-2206 <u>2/</u>	-3206 <u>2/</u>	-4206 <u>2/</u>	-5206 <u>2/</u>	5 375	-1537	-2537	-3537	-4537
2.062	-1206 <u>2/</u>	-2206 <u>2/</u>	-3206 <u>2/</u>	-4206 <u>2/</u>	-5206 <u>2/</u>	5 500	-1550	-2550	-3550	-4550
2.125	-1212	-2212	-3212	-4212	-5212	5.750	-1575	-2575	-3575	-4575
2.165	-1218 <u>2/</u>	-2218 <u>2/</u>	-3218 <u>2/</u>	-4218 <u>2/</u>	-5218 <u>2/</u>	6 000	-1600	-2600	-3600	-4600
2.188	-1218 <u>2/</u>	-2218 <u>2/</u>	-3218 <u>2/</u>	-4218 <u>2/</u>	-5218 <u>2/</u>	6 250	-1625	-2625	-3625	-4625
2.250	-1225	-2225	-3225	-4225	-5225					
2.312	-1231	-2231	-3231	-4231	-5231	6 500	-1650	-2650	-3650	-4650
2.375	-1237	-2237	-3237	-4237	-5237	6 625	-1662	-2662	-3662	-4662
2.440	-1244	-2244	-3244	-4244	-5244	6.750	-1675	-2675	-3675	-4675
2.500	-1250 <u>2/</u>	-2250 <u>2/</u>	-3250 <u>2/</u>	-4250 <u>2/</u>	-5250 <u>2/</u>	7 000	-1700	-2700	-3700	-4700
2.531	-1250 <u>2/</u>	-2250 <u>2/</u>	-3250 <u>2/</u>	-4250 <u>2/</u>	-5250 <u>2/</u>	7 250	-1725	-2725	-3725	-4725
2.562	-1256	-2256	-3256	-4256	-5256	7 500	-1750	-2750	-3750	-4750
2.625	-1262	-2262	-3262	-4262	-5262	7.750	-1775	-2775	-3775	-4775
2.677	-1268 <u>2/</u>	-2268 <u>2/</u>	-3268 <u>2/</u>	-4268 <u>2/</u>	-5268 <u>2/</u>	8 000	-1800	-2800	-3800	-4800
2.688	-1268 <u>2/</u>	-2268 <u>2/</u>	-3268 <u>2/</u>	-4268 <u>2/</u>	-5268 <u>2/</u>	8 250	-1825	-2825	-3825	-4825
2.750	-1275	-2275	-3275	-4275	-5275	8 500	-1850	-2850	-3850	-4850
2.812	-1281 <u>2/</u>	-2281 <u>2/</u>	-3281 <u>2/</u>	-4281 <u>2/</u>	-5281 <u>2/</u>	8.750	-1875	-2875	-3875	-4875
2.835	-1281 <u>2/</u>	-2281 <u>2/</u>	-3281 <u>2/</u>	-4281 <u>2/</u>	-5281 <u>2/</u>	9 000	-1900	-2900	-3900	-4900
2.875	-1287	-2287	-3287	-4287	-5287	9 250	-1925	-2925	-3925	-4925
2.953	-1300 <u>2/</u>	-2300 <u>2/</u>	-3300 <u>2/</u>	-4300 <u>2/</u>	-5300 <u>2/</u>	9 500	-1950	-2950	-3950	-4950
3.000	-1300 <u>2/</u>	-2300 <u>2/</u>	-3300 <u>2/</u>	-4300 <u>2/</u>	-5300 <u>2/</u>	9.750	-1975	-2975	-3975	-4975
						10 000	-2000	-3000	-4000	-5000

1/ SUBSTITUTE CORROSION RESISTANT STEEL WHEN USED IN FOOD PROCESSING MACHINERY, OR IN FUEL OR LUBRICATION SYSTEMS, OR WHEN USED AT TEMPERATURES OVER 450°F (233°C).

2/ SAME DASH NUMBERS SUITABLE FOR EITHER HOUSING DIAMETER (INCH OR MM).

MS16631F

TABLE IV. SUBSTITUTION TABLE (CROSS REFERENCE OF PART NUMBERS).

ØH HOUSING (REF)	INACTIVE	SUBSTITUTE	SUBSTITUTE	SUBSTITUTE	ØH HOUSING (REF)	INACTIVE	SUBSTITUTE	SUBSTITUTE	SUBSTITUTE
	CARBON STEEL	^{1/} CARBON STEEL CADMIUM PLATE	^{1/} CARBON STEEL Z NC COAT	^{1/} CARBON STEEL PHOSPHATE COAT		CARBON STEEL	^{1/} CARBON STEEL CADMIUM PLATE	^{1/} CARBON STEEL ZINC COAT	^{1/} CARBON STEEL PHOSPHATE COAT
	MS16631	MS16631	MS16631	MS16631		MS16631	MS16631	MS16631	MS16631
1.000	-100	-1100	-2100	-3100	3.062	-306	-1306	-2306	-3306
1.023	-102	-1102	-2102	-3102	3.125	-312	-1312	-2312	-3312
1.062	-106	-1106	-2106	-3106	3.149	-315	-1315	-2315	-3315
1.125	-112	-1112	-2112	-3112	3.156	-315	-1315	-2315	-3315
1.181	-118	-1118	-2118	-3118	3.250	-325	-1325	-2325	-3325
1.188	-118	-1118	-2118	-3118	3.346	-334	-1334	-2334	-3334
1.250	-125	-1125	-2125	-3125	3.469	-346	-1346	-2346	-3346
1.259	-125	-1125	-2125	-3125	3.500	-350	-1350	-2350	-3350
1.312	-131	-1131	-2131	-3131	3.543	-354	-1354	-2354	-3354
1.375	-137	-1137	-2137	-3137	3.562	-354	-1354	-2354	-3354
1.378	-137	-1137	-2137	-3137	3.625	-362	-1362	-2362	-3362
1.438	-143	-1143	-2143	-3143	3.740	-375	-1375	-2375	-3375
1.456	-145	-1145	-2145	-3145	3.750	-375	-1375	-2375	-3375
1.500	-150	-1150	-2150	-3150	3.875	-387	-1387	-2387	-3387
1.562	-156	-1156	-2156	-3156	3.938	-393	-1393	-2393	-3393
1.575	-156	-1156	-2156	-3156	4.000	-400	-1400	-2400	-3400
1.625	-162	-1162	-2162	-3162	4.125	-412	-1412	-2412	-3412
1.653	-165	-1165	-2165	-3165	4.250	-425	-1425	-2425	-3425
1.688	-168	-1168	-2168	-3168	4.331	-433	-1433	-2433	-3433
1.750	-175	-1175	-2175	-3175	4.500	-450	-1450	-2450	-3450
1.812	-181	-1181	-2181	-3181	4.625	-462	-1462	-2462	-3462
1.850	-185	-1185	-2185	-3185	4.724	-475	-1475	-2475	-3475
1.875	-185	-1185	-2185	-3185	4.750	-475	-1475	-2475	-3475
1.938	-193	-1193	-2193	-3193	5.000	-500	-1500	-2500	-3500
2.000	-200	-1200	-2200	-3200	5.250	-525	-1525	-2525	-3525
2.047	-206	-1206	-2206	-3206	5.375	-537	-1537	-2537	-3537
2.062	-206	-1206	-2206	-3206	5.500	-550	-1550	-2550	-3550
2.125	-212	-1212	-2212	-3212	5.750	-575	-1575	-2575	-3575
2.165	-218	-1218	-2218	-3218	6.000	-600	-1600	-2600	-3600
2.188	-218	-1218	-2218	-3218	6.250	-625	-1625	-2625	-3625
2.250	-225	-1225	-2225	-3225	6.500	-650	-1650	-2650	-3650
2.312	-231	-1231	-2231	-3231	6.625	-662	-1662	-2662	-3662
2.375	-237	-1237	-2237	-3237	6.750	-675	-1675	-2675	-3675
2.440	-244	-1244	-2244	-3244	7.000	-700	-1700	-2700	-3700
2.500	-250	-1250	-2250	-3250	7.250	-725	-1725	-2725	-3725
2.531	-250	-1250	-2250	-3250	7.500	-750	-1750	-2750	-3750
2.562	-256	-1256	-2256	-3256	7.750	-775	-1775	-2775	-3775
2.625	-262	-1262	-2262	-3262	8.000	-800	-1800	-2800	-3800
2.677	-268	-1268	-2268	-3268	8.250	-825	-1825	-2825	-3825
2.688	-268	-1268	-2268	-3268	8.500	-850	-1850	-2850	-3850
2.750	-275	-1275	-2275	-3275	8.750	-875	-1875	-2875	-3875
2.812	-281	-1281	-2281	-3281	9.000	-900	-1900	-2900	-3900
2.835	-281	-1281	-2281	-3281	9.250	-925	-1925	-2925	-3925
2.875	-287	-1287	-2287	-3287	9.500	-950	-1950	-2950	-3950
2.953	-300	-1300	-2300	-3300	9.750	-975	-1975	-2975	-3975
3.000	-300	-1300	-2300	-3300	10.000	-1000	-2000	-3000	-4000

^{1/} SUBSTITUTE CORROSION RESISTANT STEEL WHEN USED IN FOOD PROCESSING MACHINERY, OR IN FUEL OR LUBRICATION SYSTEMS, OR WHEN USED AT TEMPERATURES OVER 450°F (233°C).

MS16631F

NOTES:

1. UNLESS OTHERWISE SPECIFIED, DIMENSIONS ARE IN INCHES.
2. IN THE EVENT OF A CONFLICT BETWEEN THE TEXT OF THIS STANDARD AND THE REFERENCES CITED HEREIN, THE TEXT OF THIS STANDARD SHALL TAKE PRECEDENCE.
3. RECOMMENDED DESIGN LIMITATIONS AND USAGE:

- (a) INTENDED USE- TO PROVIDE SHOULDERS FOR POSITIONING AND RETAINING MACHINE COMPONENTS IN HOUSINGS. TAPERED DESIGN PRINCIPLE PERMITS RINGS TO MAINTAIN PRACTICALLY CONSTANT CIRCULARITY. THE RINGS WITH BEVEL ON OUTER CIRCUMFERENCE WHEN SPRUNG INTO GROOVE WITH TAPERED OUTER WALL CORRESPONDING TO RING BEVEL WILL SELF ADJUST AND PROVIDE SECURE PRESSURE FIT AXIALLY TO TAKE UP END PLAY. THE USE OF THE FOLLOWING FORMULAS ARE BASED ON THE FACT THAT THE RING MATERIAL WILL NOT FAIL IN COMPRESSION.

LIMITATION ON USE – THE FOLLOWING FORMULAS ARE NOT TO BE USED FOR BRITTLE MATERIALS SUCH AS CAST IRON, ETC.

WARNING: RINGS SHOULD NOT BE OVER CONTRACTED DURING INSTALLATION SINCE THIS WILL LEAD TO RING FAILURE.

- (b) ALLOWABLE THRUST LOAD CAPACITY OF THE RINGS. (ABUTTING COMPONENTS TO HAVE SHARP CORNERS)=

$$P = \frac{TH^2X}{F}$$

WHERE:

P = ALLOWABLE THRUST LOAD (POUNDS)
H = HOUSING DIAMETER (INCHES)
T = RING THICKNESS (INCHES)
X = ULTIMATE SHEAR STRENGTH OF THE RING MATERIAL (PSI) ^{1/}
F = FACTOR OF SAFETY

A FACTOR OF SAFETY, F=4, IS RECOMMENDED, SINCE THE RING UNDER LOAD IS SUBJECTED NOT ONLY TO PURE SHEAR STRESSES BUT ALSO TO BENDING STRESSES.

- (c) ALLOWABLE LOAD CAPACITY OF GROOVE WALL =

$$P = \frac{TH^2d}{F}$$

WHERE:

P = ALLOWABLE COMPRESSION LOAD (POUNDS)
H = HOUSING DIAMETER (INCHES)
d = GROOVE DEPTH (INCHES)
Y = YIELD STRENGTH IN COMPRESSION OF THE GROOVE MATERIAL (PSI)
F = FACTOR OF SAFETY

TO INSURE A SAFE WORKING LOAD A SAFETY FACTOR, F = 2, IS RECOMMENDED.

- (d) MINIMUM DISTANCE BETWEEN OUTER GROOVE WALL AND END OF HOUSING =

$$Z = 1.5d$$

WHERE:

Z = MINIMUM DISTANCE BETWEEN OUTER GROOVE WALL AND END OF HOUSING (INCHES)
d = GROOVE DEPTH (INCHES)

- (e) DEFLECTION, (UNDER LOAD) =

$$\Delta_L = \frac{L^2}{2E}$$

WHERE:

d = GROOVE DEPTH (INCHES)
E = YOUNG'S MODULUS OF ELASTICITY OF GROOVE MATERIAL
L = APPLIED LOAD (POUNDS)
 Δ_L = DEFLECTION, AT LOAD "L" (INCHES)

^{1/} X = 150,000 PSI ULTIMATE SHEAR STRENGTH FOR RINGS OF CARBON STEEL AND CORROSION RESISTANT STEEL.

X = 110,000 PSI ULTIMATE SHEAR STRENGTH FOR RINGS OF BERYLLIUM COPPER.

^{2/} $\frac{d}{2}$ = HALF OF THE GROOVE DEPTH OF THE BEVELED GROOVE WILL MAINTAIN THE MINIMUM CONTACT AREA OF RING IN GROOVE. ALLOWABLE LOAD CALCULATION SHOULD BE BASED ON $\frac{d}{2}$.

MS16631F

(f) LOCATION OF GROOVE =

(1) MINIMUM INSERTION OF RING IN GROOVE =

$$L_{\text{MIN}} \geq M_{\text{MAX}} + U_{\text{MAX}} + \text{TAKE-UP (AS LISTED)}$$

(2) MAXIMUM INSERTION OF RING IN GROOVE =

$$L_{\text{MAX}} \leq M_{\text{MIN}} + U_{\text{MIN}} + 2 \text{ TIMES TAKE-UP (AS LISTED)}$$

(3) TAKE-UP = IN ORDER TO FUNCTION PROPERLY THE RING TAKE-UP SHOULD EXCEED THE SUM TOTAL OF THE TOLERANCES.

$$\text{TAKE-UP} > \Delta L + \Delta M + \Delta U \quad \text{WHERE: } \Delta L = L_{\text{MAX}} - L_{\text{MIN}}$$

$$\Delta M = M_{\text{MAX}} - M_{\text{MIN}}$$

$$\Delta U = U_{\text{MAX}} - U_{\text{MIN}}$$

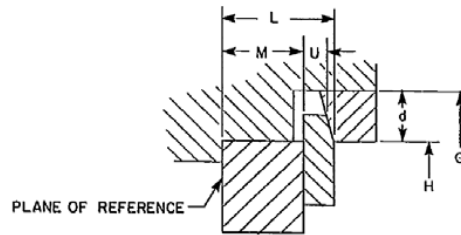

(g) VIBRATION = A RETAINING RING WILL BE SECURE AGAINST VIBRATION IF ITS SHEAR FATIGUE STRENGTH EQUALS OR EXCEEDS THE FORCE CREATED BY THE MASS OF THE PARTS BEING REPEATEDLY ACCELERATED AGAINST THE RING.

(1) SHEAR STRENGTH OF RING (CRITICAL). ABUTTING COMPONENTS TO HAVE SHARP CORNERS.

$$XT \ 1.1 H \geq \frac{W}{g} a$$

OR FOR HARMONIC MOTION

$$a = \delta \omega^2$$

$$XT \ 1.1 H \geq \frac{W}{g} \delta \omega^2$$

WHERE:

X = ULTIMATE SHEAR STRENGTH OF RING MATERIAL (PSI) ^{3/}

T = RING THICKNESS (INCHES)

H = HOUSING DIAMETER (INCHES)

W = WEIGHT OF ABUTTING PARTS (POUNDS)

g = ACCELERATION DUE TO GRAVITY (IN/SEC²) δ = AMPLITUDE OF VIBRATION (INCHES)a = ACCELERATION (IN/SEC²) ω = ANGULAR SPEED (RAD/SEC)

(2) COMPRESSION STRENGTH OF GROOVE MATERIAL (CRITICAL) =

$$Y \frac{d}{2} \ 1.65 H \geq \frac{W}{g} \delta \omega^2$$

WHERE:

Y = YIELD STRENGTH IN COMPRESSION OF THE GROOVE MATERIAL (PSI)

d = GROOVE DEPTH (INCHES)

OTHER SYMBOLS AS SHOWN IN (1) ABOVE

(h) IMPACT CAPACITY OF RING OR GROOVE WALL =

$$I_R = \frac{PT}{2} \quad \text{FOR THE RING (INCH POUNDS), ABUTTING COMPONENTS TO HAVE SHARP CORNERS.}$$

$$I_G = \frac{Pd}{4} \quad \text{FOR THE GROOVE (INCH POUNDS).}$$

WHERE:

P = ALLOWABLE THRUST LOAD OF RING OR GROOVE (POUNDS).

T = RING THICKNESS (INCHES).

I_G = IMPACT CAPACITY OF GROOVE WALL (INCH POUNDS).

d = GROOVE DEPTH (INCHES).

I_R = IMPACT CAPACITY OF RING (INCH POUNDS).

^{3/} X = 150,000 PSI ULTIMATE SHEAR STRENGTH FOR RINGS OF CARBON STEEL AND CORROSION RESISTANT STEEL..
X = 110,000 PSI WORKING SHEAR STRENGTH FOR RINGS OF BERYLLIUM COPPER.

MS16631F

(i) LOAD CAPACITY = (WITH THE RETAINED PART RADIUSED OR CHAMFERED).

WHEN THE RADIUS OR CHAMFER OF THE RETAINED PART DOES NOT EXCEED THE MAXIMUM RADIUS ALLOWED FOR THE BOTTOM OF THE RING GROOVE, THE LESSER LOAD CAPACITY COMPUTED FROM THE FORMULAS ON SHEETS 8 AND 9 WILL APPLY. THE CORNER RADII AND CHAMFERS LISTED ON SHEETS 2, 3 AND 4 WERE CHOSEN AS LARGE AS POSSIBLE FOR THE RING SIZES INVOLVED AND ARE RELATED TO THE MAXIMUM THRUST LOADS LISTED IN TABLE V.

IF THE CORNER RADII OR CHAMFERS ARE SMALLER THAN THOSE LISTED, THEN THE THRUST LOADS INCREASE PROPORTIONALLY, IN ACCORDANCE WITH THE FOLLOWING FORMULAS:

$$P^1 = \frac{P \cdot CH}{CH^1} \quad \text{OR}$$

WHERE:

$$P^1 = \frac{P \cdot R}{R^1}$$

P^1 = NEW ALLOWABLE THRUST LOAD.

P = LISTED ALLOWABLE THRUST LOAD.

CH^1 = NEW (SMALLER) CHAMFER.

CH = LISTED CHAMFER.

R^1 = NEW (SMALLER) CORNER RADIUS.

R = LISTED CORNER RADIUS.

LIMIT LOADS LISTED IN TABLE V ARE BASED ON RINGS OF STEEL (WORKING STRESS = 250,000 P.S.I.) AND OF BERYLLIUM COPPER (WORKING STRESS = 180,000 P.S.I.). IF THE ALLOWABLE GROOVE CAPACITY LOADS AS CALCULATED BY USING THE FORMULA ON PAGES 8, 9 AND 10 ARE LESS, THEN THEY SHOULD BE USED.

TABLE V. LIMIT LOADS.

NOMINAL RING SIZE		ALLOWABLE THRUST LOAD FOR RING ASSEMBLIES WITH PARTS HAVING MAXIMUM CORNER RADII OR CHAMFERS.	
FROM	TO	CARBON STEEL OR CORROSION RESISTANT STEEL	BERYLLIUM COPPER
1.000	1.500	2400 LB	1700 LB
1.562	2.000	3900 LB	2800 LB
2.062	2.531	6200 LB	
2.562	3.000	9000 LB	
3.062	5.000	12000 LB	
5.250	6.000	15000 LB	
6.250	7.000	23000 LB	
7.250	10.000	34000 LB	

4. Changes from previous issue. The margins of this specification are marked with vertical lines to indicate where changes from the previous issue were made. This was done as a convenience only and the Government assumes no liability whatsoever for any inaccuracies in these notations. Bidders and contractors are cautioned to evaluate the requirements of this document based on the entire content irrespective of the marginal notations and relationship to the last previous issue.

MS16631F

MILITARY INTEREST

Custodians:

Army - AR
Navy - OS
Air Force - 99

Preparing activity:

DLA - IS

(Project 5325-2014-002)

Review activities:

Army – AV

NOTE: The activities listed above were interested in this document as of the date of this document. Since organizations and responsibilities can change, you should verify the currency of the information above using the ASSIST Online database at <https://assist.dla.mil>.