

FED. SUP. CLASS
5310

This standard limits the sizes and material of special design galvanized steel lock washers for use by the Bureau of Ships to those shown hereon. It is mandatory for use effective on date of issue.

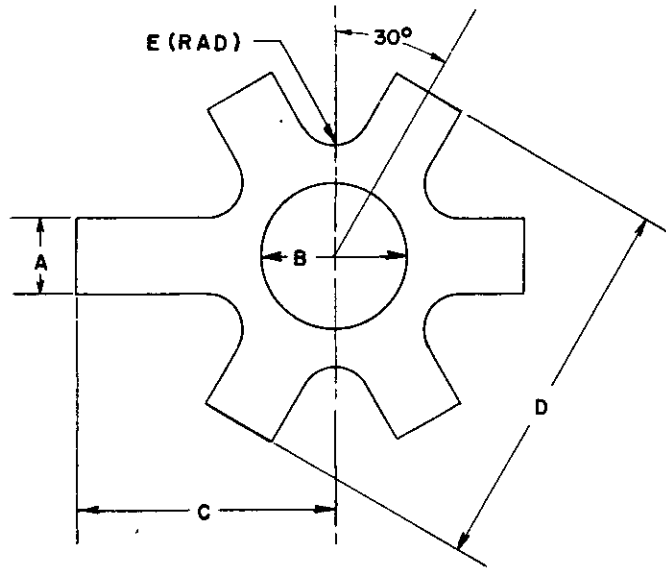

NOTE: When Government drawings, specifications, or other data are used for any purpose other than in connection with a definitely related Government procurement operation, the United States Government thereby incurs no responsibility, nor any obligation whatsoever; and the fact that the Government may have furnished, furnished, or in any way supplied the said drawings, specifications, or other data is not to be regarded by implication or otherwise as in any manner licensing the holder or any other person or corporation, or conveying any rights or permission to manufacture, use, or sell any patented invention that may in any way be related thereto.

MS part number	Bolt D. in.	Dimensions (inches)					Thickness Inch	FIIN
		A	B	C	D	E		
MS 15820-1	3/8	1/4	17/32	1	1-1/4	3/64	.05	
MS 15820-2	1/2	5/16	17/32	1-1/8	1-1/2	1/16	.05	
MS 15820-3	5/8	3/8	21/32	1-1/4	1-3/4	3/16	.05	
MS 15820-4	3/4	3/8	25/32	1-3/8	2	3/16	.05	
MS 15820-5	7/8	5/16	29/32	1-1/2	2-1/4	1/4	.05	
MS 15820-6	1	1/2	1-1/16	1-3/4	2-1/2	--	.05	
MS 15820-7	1-1/8	1/2	1-3/16	1-3/4	2-1/2	--	.05	
MS 15820-8	1-1/4	1/2	1-5/16	1-7/8	2-5/8	3/8	.05	

1: Material shall conform to type I, class 4 of Specification QQ-S-775.

(A) CANCELED AFTER 5 AUGUST 1986. NO SUPERSEDING STANDARD.
(PROJECT 5310-N042)

APPROVED 15 SEPT 1954 REVISED (A) 5 AUGUST 1986

CUSTODIANS Ships	OTHER INT. A - N - AF -	MILITARY STANDARD	MS15820 (SHIPS)
		WASHERS, LOCK SPECIAL DESIGN, GALVANIZED STEEL	
Procurement Specification None	SUPERSEDES:		SHEET 1 OF 1