

**NOT MEASUREMENT  
SENSITIVE**

**MIL-STD-3001-5A(AS)  
10 October 2014  
SUPERSEDING  
MIL-STD-3001-5(AS)  
15 May 2001**

# **DEPARTMENT OF DEFENSE STANDARD PRACTICE**

**DIGITAL TECHNICAL INFORMATION  
FOR  
MULTI-OUTPUT PRESENTATION  
OF  
TECHNICAL MANUALS**

**AIRCRAFT WIRING INFORMATION  
(PART 5 OF 8 PARTS)**



AMSC

AREA TMSS

**DISTRIBUTION STATEMENT A. Approved for public release; distribution is unlimited.**

## MIL-STD-3001-5A(AS)

**FOREWORD**

1. This standard is approved for use by the Department of the Navy and is available for use by all Departments and Agencies of the Department of Defense.
2. This eight-part standard establishes the requirements needed to prepare digital technical information for multi-output presentation of NAVAIR work package (WP) Technical Manuals (TMs). The technical content and mandatory style and format requirements contained in this eight-part standard can be used to develop and assemble complete TMs for aircraft weapon systems, aeronautical equipment, airborne weapons/equipment, and support equipment WP TMs. The requirements are applicable for the output of printed paper and PDF screen displayed TMs. The requirements are also applicable for the display of Interactive Electronic Technical Manuals (IETMs) on any viewer that supports MIL-STD-3001-1.
3. MIL-STD-3001-5 is Part 5 of 8 parts and is incomplete without Parts 1 through 4 and Parts 6 through 8. Part 5 establishes the technical content requirements for the preparation of wiring information for the aircraft and its systems, subsystems, and equipment. This data can be used to develop TMs in a variety of output forms, including interactive screen presentations and page-based printed and PDF screen displayed TMs.
4. MIL-STD-3001-1 contains general preparation requirements for the multi-output presentation of NAVAIR WP TMs. MIL-STD-3001-2 through MIL-STD-3001-8 contain specific functional technical content requirements for the preparation of all NAVAIR WP TMs and revisions. Parts 1 through 8 are identified below:

MIL-STD-3001-1	Preparation of Digital Technical Information for Multi-output presentation of Technical Manuals.
MIL-STD-3001-2	Description, Principles of Operation, and Operation Data.
MIL-STD-3001-3	Testing and Troubleshooting Procedures.
MIL-STD-3001-4	Maintenance Information with Illustrated Parts Breakdown (IPB).
MIL-STD-3001-5	Aircraft Wiring Information.
MIL-STD-3001-6	Structural Repair Information.
MIL-STD-3001-7	Periodic Maintenance Requirements.
MIL-STD-3001-8	Separate Illustrated Parts Breakdown (IPB).

5. Comments, suggestions, or questions on this document should be addressed to the Naval Air Systems Command (Commander, Naval Air Warfare Center Aircraft Division, Code 412000B120-3, Highway 547, Lakehurst, NJ 08733-5100) or emailed to [michael.sikora@navy.mil](mailto:michael.sikora@navy.mil). Since contact information can change, you may want to verify the currency of this address information using the ASSIST online database at <https://assist.dla.mil>.

## MIL-STD-3001-5A(AS)

## CONTENTS

<u>PARAGRAPH</u>	<u>PAGE</u>
<b>FOREWORD</b> .....	ii
<b>1. SCOPE</b> .....	1
1.1 Scope.....	1
<b>2. APPLICABLE DOCUMENTS</b> .....	1
<b>3. DEFINITIONS</b> .....	1
<b>4. GENERAL REQUIREMENTS</b> .....	1
4.1 General.....	1
4.2 Maintenance level applicability.....	1
4.3 Selective application and tailoring.....	1
4.4 Preparation of digital data for electronic delivery.....	1
4.4.1 Use of the DTDs.....	2
4.5 Technical content.....	2
4.5.1 Types of work packages.....	2
4.5.2 Style and format requirements.....	2
4.6 Standard tables and lists.....	2
<b>5. DETAILED REQUIREMENTS</b> .....	2
5.1 Preparation of aircraft wiring information.....	2
5.2 Work package content.....	2
5.2.1 Title block <titleblk>.....	3
5.2.2 Work package information <wpinfo> ( <b>Aircraft Wire Bundle Manual and Aircraft Wiring Connector Repair Manual only</b> ).....	3
5.2.2.1 Reference material list <reflist>.....	3
5.2.2.2 Record of Applicable Technical Directives <ratd>.....	4
5.2.2.3 Support equipment required list <selist>.....	5
5.2.2.4 Facilities required list <faclist>.....	5
5.2.2.5 Materials required list <matlist>.....	5
5.2.3 Required aircraft wiring diagram information.....	6
5.2.3.1 Identification and numbering of aircraft wires, cables, harnesses, and other miscellaneous parts.....	6
5.2.3.2 Wiring diagram identification and information work package <wdiawp>.....	6
5.2.3.3 Wiring diagram work packages <wdiawp>.....	7
5.2.3.4 Wire list work packages.....	8
5.2.3.4.1 Wire run list work package <wrunlstwp>.....	8
5.2.3.4.2 Wiring reference designation list work package <wrefdeswp>.....	8
5.2.3.5 Wire and connector component identification and location list work package <wcomplstwp>.....	8
5.2.4 Required aircraft wire bundle information.....	8
5.2.4.1 Wiring system bundle assembly identification and information work package <bunidwp>.....	9
5.2.4.2 Access information work package <accessinfowp>.....	9
5.2.4.3 Wire bundle assembly routing work packages <bunroutewp>.....	10
5.2.5 Required aircraft wiring connector repair information.....	10
5.2.5.1 Development of aircraft wire connector repair work packages.....	10
5.2.5.2 Wiring systems repair identification and information work package <wrepidwp>.....	11

## MIL-STD-3001-5A(AS)

## CONTENTS

<u>PARAGRAPH</u>	<u>PAGE</u>
5.2.5.3 Wiring system component repair tool list work package <comprelistwp> ( <b>standard military type components only</b> ).....	11
5.2.5.4 Aircraft specific wiring systems repair kit work package <reprkitwp>.....	12
5.2.5.5 Wire type list work package <wtypelistwp>.....	12
5.2.5.6 Aircraft specific repair tools work package <reptoolwp>.....	12
5.2.5.7 Wiring system connector component repair work packages <wcomprepwp>.....	13
5.2.5.7.1 Terminals, ring tongue crimped barrel installation .....	14
5.2.5.7.2 Shielded terminal ferrules (high temperature).....	14
5.2.5.7.3 Electrical cable assemblies sealing.....	15
5.2.5.7.4 Circular and rectangular connectors.....	15
5.2.5.7.5 Single contact and triaxial connectors.....	16
5.2.5.7.6 Protective boot installation for environmental type connectors with metal or molded plastic cable clamps.....	16
5.2.5.7.7 Fabrication of shielded harness terminated with electromagnetic interference backshells	17
5.2.5.7.8 Silicone rubber tape boots .....	18
5.2.5.8 Aircraft cable assembly parts data work package <partswp>.....	18
6. <b>NOTES</b> .....	19
 <u>FIGURE</u>	
FIGURE 1. Example of aircraft wiring systems circuit identification.....	20
FIGURE 2. Example of wire identification. ....	24
FIGURE 3. Example of an aircraft wire run list. ....	25
FIGURE 4. Example of a wiring reference designation list. ....	26
FIGURE 5. Example of a reference designation aircraft section identification.....	27
FIGURE 6. Example of an access door and area location list. ....	29
FIGURE 7. Example of aircraft wire bundle routing.....	32
FIGURE 8. Example of an aircraft wire bundle parts list.....	33
FIGURE 9. Example of a wire type list. ....	34
FIGURE 10. Example of cable assembly repair parts data.....	35

## MIL-STD-3001-5A(AS)

## 1. SCOPE

1.1 Scope. This part of the standard establishes the technical content requirements for the preparation of wiring information for the aircraft and its systems, subsystems, and equipment. This data can be used to develop TMs in a variety of output forms, including interactive screen presentations and page-based printed and screen displayed PDF TMs.

## 2. APPLICABLE DOCUMENTS

The applicable documents in Section 2 of MIL-STD-3001-1 apply to this Part.

## 3. DEFINITIONS

The definitions in Section 3 of MIL-STD-3001-1 apply to this Part.

## 4. GENERAL REQUIREMENTS

4.1 General. Sufficient information shall be developed necessary for a user to familiarize and comprehend the wiring for the aircraft weapon system, subsystem, and equipment. Wiring diagrams and/or wiring lists shall be included. In addition, specific wire and connector repair information peculiar to the aircraft being covered shall also be developed. This wiring data shall be used by organizational level personnel to support associated aircraft maintenance procedures and to perform maintenance on aircraft wiring systems.

4.2 Maintenance level applicability. Requirements contained in this standard are applicable to all types and maintenance levels of TMs unless specifically noted in bold and in parentheses (i.e., **Support Equipment Manuals only, Depot Level only**, etc.).

4.3 Selective application and tailoring. This Part contains some requirements that may not be applicable to the preparation of all TMs. Selective application and tailoring of requirements contained in this Part shall be accomplished through the use of the Technical Manual Content Selection Matrixes contained in MIL-STD-3001-1, Appendix A. The applicability of some requirements is also designated by one of the following statements: unless specified otherwise by the requiring activity or as/when specified by the requiring activity.

4.4 Preparation of digital data for electronic delivery. Technical manual data prepared and delivered digitally in accordance with this Part shall be XML-tagged and assembled using the modular Document Type Definition (DTD). Refer to MIL-STD-3001-1 for information on obtaining or accessing this modular DTD. XML tags used in the modular DTD are noted throughout the text of this standard in bracketed, bold characters (i.e., **<acwirim>**) as a convenience for the TM author and to denote the appropriate tag to be used for the specific information when developing a document instance.

## MIL-STD-3001-5A(AS)

4.4.1 Use of the DTDs. The modular DTDs referenced in this Part interpret the technical content and structure for the functional requirements contained in this Part and are mandatory for use.

4.5 Technical content. Technical content requirements contained in this Part are considered mandatory and are intended for compliance. The content structure for the technical data being developed shall conform to the associated modular Document Type Definition (DTD) for Aircraft Wiring information.

4.5.1 Types of work packages. There are basically two types of WPs. The first type is an information-oriented WP. It provides information such as general information about the printed technical manual or the IETM and specific information about the weapon system/equipment, such as principles of operation and operating instructions. The second type of WP is task-oriented. Task-oriented WPs reflect all required maintenance tasks, including testing and troubleshooting, at the assigned level of maintenance. Task-oriented WPs also contain supporting information such as required materials and support equipment required for each defined task. WPs are written to reflect the engineering design, Logistics Support Analysis (LSA) or Logistics Management Information (LMI), Level of Repair Analysis (LORA), approved maintenance plan, and the established repair concept (SM&R Codes).

4.5.2 Style and format requirements. For mandatory style and format requirements for WP TMs intended for a printed, page-oriented presentation, refer to MIL-STD-3001-1, Appendix B. For style and format requirements for the on-screen display of IETMs, refer to NAVAIRINST 4120.11, Policy for Preparation and Standardization of the Naval Air Systems Command Interactive Electronic Technical Manuals (IETMs).

4.6 Standard tables and lists. Standard tables and lists are noted throughout the text of this standard in bold and in parentheses (i.e., **(standard table)**, **(standard list)**). The structure and titles of the column headings for these standard tables and lists shall have no deviations.

## 5. DETAILED REQUIREMENTS

5.1 Preparation of aircraft wiring information. Aircraft wiring information shall be developed and contained in an Aircraft Wiring Diagram Information Module <acwirim>, an Aircraft Wire Bundle Information Module <acwirbunim>, or an Aircraft Wire Connector Repair Information Module <acconnrepim>. These information modules shall be logically subdivided into information- or task-oriented WPs.

5.2 Work package content. Each WP developed for aircraft wiring information shall consist of the following:

- a. Title block.
- b. WP information. (**Aircraft Wire Bundle Manual and Aircraft Wiring Connector Repair Manual only**)

## MIL-STD-3001-5A(AS)

- c. Required aircraft wiring diagram information.
- d. Required aircraft wire bundle information.
- e. Required aircraft wire connector repair information.

5.2.1 Title block <titleblk>. For page-based TMs, refer to MIL-STD-3001-1, Appendix B, for WP title block content requirements. For IETMs, refer to MIL-STD-3001-1, Appendix C.

5.2.2 Work package information <wpinfo> (Aircraft Wire Bundle Manual and Aircraft Wiring Connector Repair Manual only). Each WP developed for aircraft wiring information shall begin with a reference material list, a record of applicable technical directives, a support equipment required list, a facilities required list, and a materials required list, if applicable.

5.2.2.1 Reference material list <reflist>. Reference material required to complete a task or discussion within a WP shall be contained in a reference material list (**standard list**). If no reference material applies, the heading "Reference Material" shall be omitted from the WP. Guidelines for developing the reference material list are provided below:

- a. Only those publications required for performance of the task covered by the WP shall be included in the reference material list.
- b. Publications such as guides or standards which are not directly needed to accomplish the task (backup informational material or bibliography) shall not be listed in the reference material list even if cited in the WP text.
- c. Each entry in the list shall consist of:
  - (1) A title. Referenced publications within the WP by title. If the reference is to a specific WP, the WP title shall be listed below the related publication title.
  - (2) A number. The appropriate publication or WP number.
- d. The maintenance level of publications listed is not required.
- e. Referenced publications shall be presented by title in alphabetical order. The publication title, WP title, and WP number shall also be identified. When two or more WPs are referenced in the same manual, they shall be listed in numerical sequence; repetition of the manual title and publication number is not required.
- f. Additional WPs within the same manual that are required to complete the task or discussion shall be presented first in numerical sequence. The WP title and WP number shall also be identified. The publication number is not required.
- g. Referenced publications not prepared in WP format shall be presented in numerical sequence. The title and publication number shall also be included.

## MIL-STD-3001-5A(AS)

5.2.2.2 Record of Applicable Technical Directives <ratd>. Technical directives applicable to a specific WP shall be listed in a record of applicable technical directives list (**standard list**). If no technical directives apply, the heading "Record of Applicable Technical Directives" shall be omitted from the WP. The record of technical directives shall be prepared in accordance with the following guidelines:

a. All issued technical directives having any impact on the WP shall be listed upon incorporation into the WP.

b. Approved engineering change proposals (ECPs) that have no effect on retrofit of the end item shall not be listed in the record of applicable technical directives (e.g., "no technical directive will be issued").

c. All technical directives and related ECPs or Rapid Action Minor Engineering Changes (RAMECs) shall be listed upon incorporation into the WP.

(1) "TD Type/No." - Enter the type and number of the technical directive (e.g., "F/A-18 AFC 126" or "AVC 102." Note: The "TD Type/No." is identified on the Change Control Board (CCB) formal letter of ECP or RAMEC Directives System.

(2) "TD Date" - Enter the date of issue of the technical directive. If the number of the technical directive has been assigned but the directive has not been issued, a dash (-) shall be entered.

(3) "Title and ECP/RAMEC No." - The title of the technical directive and the ECP number or RAMEC, if applicable, shall be listed. If a technical directive listed is the direct result of an approved ECP or RAMEC, the acronym ECP or RAMEC and number shall be shown in parentheses following the technical directive title.

(4) "Date Inc." - The date the information affected by the technical directive or the ECP was incorporated into the WP.

(a) If the technical directive number has been assigned and the directive has not yet been issued (retrofit program), but the ECP that incorporates the change in the production program has been approved, the production ECP coverage shall be included, and the notation "Production coverage only" shall be entered under "Remarks."

(b) When the retrofit TD is approved and incorporated in a change or revision following the incorporation of the production ECP coverage, the TD date of issue shall be entered under "TD Date," the notation "Production coverage only" shall be removed from under "Remarks," and the date of retrofit coverage incorporation shall be listed under "Date Inc." (in lieu of the production ECP coverage incorporation date).

(5) "Remarks" - Enter any applicable remarks.



## MIL-STD-3001-5A(AS)

5.2.2.3 Support equipment required list <selist>. All support equipment (SE), including special tools required to perform operational type procedures, shall be listed (**standard list**) immediately following the record of applicable technical directive data. If no support equipment is required, the heading "Support Equipment Required" shall be omitted from the WP. Only those special tools (including torque wrenches) and equipment authorized for use at the level of maintenance covered shall be listed. Items shall be listed in alphabetical sequence by noun nomenclature. Standard hand tools shall not be listed. Illustrations shall not be prepared in support of such lists. When the manual is used by other services or commands that require usage restrictions, the item shall be identified by a symbol following the part number in parentheses. The usage of the symbol shall be explained in a notation (e.g., "(AF)=USAF only," "(NS)=NAVSEA only," "(MC)=MARINE CORPS only").

5.2.2.3.1 Each support equipment entry in the list shall be identified by "Nomenclature," "Part Number," and "CAGE Code." When more than one of the same item is required, the quantity shall follow the nomenclature in parentheses. If a "CAGE Code" is not available a dash shall be substituted for the "CAGE Code".

5.2.2.3.2 If the WP contains multilevel maintenance procedures and any of the SE items are authorized for use at only certain level(s), the restrictive use shall be indicated by the use of an O, I, and/or D in parentheses following the item nomenclature. For **Aircraft Engine Manuals** the following special application codes to identify usage restrictions shall be used:

- a. "J" shall be used to indicate the first degree engine maintenance level,
- b. "8" shall be used to indicate the second degree engine maintenance level, and
- c. "9" shall be used to indicate the third degree engine maintenance.

5.2.2.4 Facilities required list <faclist>. All facilities needed to accomplish the maintenance procedures shall be listed (**standard list**) immediately following the support equipment required list. If no facilities are required, the heading "Facilities Required" shall be omitted from the WP. Each facilities entry in the list shall be identified by "Nomenclature," "Part Number," and "CAGE Code."

5.2.2.5 Materials required list <matlist>. All materials (consumable materials and/or expendable items) required to perform maintenance type procedures shall be listed (**standard list**). If no materials apply, the heading "Materials Required" shall be omitted from the WP. Items shall be listed in alphabetical sequence by noun nomenclature. The materials required list shall be prepared in accordance with the following guidelines:

- a. Each material entry in the list shall be identified by "Nomenclature," "Specification/Part Number," and "HMWS Index Number," as applicable.

(1) Unless alternate identification is approved by the requiring activity, materials shall be listed by Government specification.

## MIL-STD-3001-5A(AS)

(2) If the WP contains multilevel maintenance procedures and any of the materials are authorized for use at only certain level(s), the restriction shall be indicated by the use of an O, I, and/or D in parentheses following the item nomenclature.

(3) When more than one of the same item is required, the quantity shall follow the nomenclature in parentheses.

b. Parts that require mandatory replacement (e.g., preformed packing) in the procedure shall be listed.

c. An appropriate notation shall follow the item to explain each restriction and/or quantity requirement.

5.2.3 Required aircraft wiring diagram information. Wiring diagram documentation shall be prepared to facilitate understanding of the functions and makeup of each power, control, and signal interface with electronic and mechanical systems. They shall present a means for accomplishing the tracing of each circuit and its relationship to interconnected electronic and mechanical systems. Aircraft wiring diagrams may be produced as either foldout illustrations or adapted to fit a landscape 8-1/2 x 11-inch format to facilitate on-aircraft troubleshooting. Aircraft wiring repair information shall not be included in these WPs. Aircraft wiring diagram information shall be developed and divided into the following WPs:

- a. Wiring diagram identification and information WP.
- b. Wiring diagram WPs.
- c. Wire list WPs.
- d. Wire and connector component identification and location list WP.

5.2.3.1 Identification and numbering of aircraft wires, cables, harnesses, and other miscellaneous parts. The identification and numbering of aircraft wiring systems and associated cables, harnesses, and other miscellaneous parts such as splices and ground points shall be in accordance with SAE-AS50881, Aerospace Vehicle Wiring (see [figures 1](#) and [2](#)). Reference designations shall be assigned in accordance with ASME Y14.44, Reference Designations for Electrical and Electronics Parts and Equipment.

5.2.3.2 Wiring diagram identification and information work package <wdiaidwp>. An explanation of how the aircraft wiring systems diagrams and lists are identified and defined shall be included in this WP. The heading "WIRING SYSTEM DIAGRAM IDENTIFICATION AND INFORMATION" shall appear in the title block of this WP. The WP shall include the following elements, as applicable:

a. Introduction <intro>. A general explanation of the intent and contents of this WP shall be included.

## MIL-STD-3001-5A(AS)

b. Reference designator system. An explanation of the aircraft reference designator system shall be included.

c. Individual cable numbering. An explanation of how all aircraft cables are identified shall be provided. All possible configurations shall be addressed (i.e., coaxial, triaxial, shielded, and unshielded). Supporting illustrations may be used to enhance the explanation.

d. Electrical connector identification. An explanation of how all aircraft electrical connectors are identified shall be provided. Supporting illustrations may be used to enhance the explanation.

e. Splice area identification. An explanation of how all aircraft splice areas are identified shall be provided. Supporting illustrations may be used to enhance the explanation.

f. Ground point identification. An explanation of how all aircraft ground points are identified shall be provided. Supporting illustrations may be used to enhance the explanation.

g. Individual wire identification. An explanation of how all aircraft individual wires are identified shall be provided. Supporting illustrations may be used to enhance the explanation.

5.2.3.3 Wiring diagram work packages <wdiawp>. Wiring diagrams shall be developed that adequately contain the maintenance data required by the technician to complete the maintenance task for an aircraft system or aircraft wiring maintenance. A series of wiring diagram WPs shall be developed, as required, to illustrate or list the wiring of all aircraft systems, subsystems, and equipment. Wiring diagrams are not required for devices that are simple to interconnect and are supported by wire lists. Wiring diagrams shall be developed in accordance with MIL-STD-3001-1, Appendix D, and the following additional requirements:

a. WP information ([5.2.2](#)) is not required for individual wiring diagram WPs. This information shall be included in the introductory information in the front of the aircraft wiring diagram manual.

b. The diagrams shall be incorporated into WPs in the general order of work flow as dictated by the maintenance concept developed from the LSA/LMI, the Level of Repair Analysis (LORA), or the approved maintenance plan, and the established repair concept (SM&R codes).

c. Junction box and panel wiring diagrams not included on system wiring diagrams shall be presented in their complete form.

d. Wire, connector, and pin numbers shall be included in all aircraft wiring diagrams to accomplish troubleshooting and traceability of each circuit.

## MIL-STD-3001-5A(AS)

5.2.3.4 Wire list work packages. Two types of wire list WPs shall be developed. The first is a wire run list WP. The second type is a wiring reference designation list WP. WP information (5.2.2) is not required for individual wire list WPs. This information shall be included in the introductory information in the front of the aircraft wiring diagram manual.

5.2.3.4.1 Wire run list work package <wrunlstwp>. The wire run list WP shall contain a list of all wires <wrunlst> for the aircraft systems, subsystems, and equipment (see [figure 3](#)). Wires shall be listed in alphanumeric sequence by system wire number. For each wire listed, the following data shall be provided:

- a. The wiring diagram on which the wire is illustrated.
- b. Length of wire.
- c. The wire from-to information by item reference designation/pin number.
- d. The wire harness part number of which the wire is a part.
- e. The aircraft effectivity. When applicable, end item effectivity shall be indicated by code. The code shall be explained in the introductory matter of the WP.

5.2.3.4.2 Wiring reference designation list work package <wrefdeswp>. The wiring reference designation list WP shall contain a list of all wiring component reference designations and pin numbers <wrefdeslst> (see [figure 4](#)). For each reference designation pin listed, the following data shall be provided:

- a. The wire number segment connected to the pin.
- b. The point of termination (of the wire segment) reference designation number shall be listed.
- c. When applicable, the cable assembly or harness number shall be listed. If the end item covered does not utilize cable or harness installations, this entry shall be omitted.
- d. When applicable, end item effectivity shall be indicated by code.

5.2.3.5 Wire and connector component identification and location list work package <wcomplstwp>. A list of all wiring termination components such as splices, terminal boards, ground studs, etc., shall be provided. Each component shall be listed by reference designation and location in the aircraft. Location shall be by aircraft water and butt lines and access cover, if applicable.

5.2.4 Required aircraft wire bundle information. Information for the identification, location, and repair of aircraft wiring bundle assemblies (harnesses) shall be divided into the following types of WPs:

## MIL-STD-3001-5A(AS)

- a. Wiring system bundle assembly identification and information WP.
- b. Access information WP.
- c. Wire bundle assembly routing and parts data WPs.

5.2.4.1 Wiring system bundle assembly identification and information work package <bunidwp>. An explanation of how the aircraft wiring systems bundle assemblies are identified and defined shall be included in this WP. The heading "WIRING SYSTEM BUNDLE ASSEMBLY IDENTIFICATION AND INFORMATION" shall appear in the title block of this WP. The WP shall include the following elements, as applicable:

- a. Introduction <intro>. A general explanation of the intent and contents of this WP.
- b. Reference designator system. An explanation of the aircraft reference designator system.
- c. Aircraft section identification. The various sections that comprise the aircraft shall be identified and listed, supported by illustrations showing the specific areas of the aircraft (see [figure 5](#)).
- d. Individual harness identification. An explanation of how the aircraft harness assemblies are identified. Supporting illustrations may be used to enhance the explanation.
- e. Individual cable numbering. An explanation of how all aircraft cables are identified. All possible configurations shall be addressed (i.e., coaxial, triaxial, shielded, and unshielded). Supporting illustrations may be used to enhance the explanation.
- f. Electrical connector identification. An explanation of how all aircraft electrical connectors are identified. Supporting illustrations may be used to enhance the explanation.
- g. Splice area identification. An explanation of how all aircraft wiring splice areas are identified. Supporting illustrations may be used to enhance the explanation.
- h. Ground point identification. An explanation of how all aircraft ground points are identified. Supporting illustrations may be used to enhance the explanation.
- i. Individual wire identification. An explanation of how all aircraft individual wires are identified. Supporting illustrations may be used to enhance the explanation.
- j. Circuit identification. An explanation of how the application of circuit identification on aircraft wires is assigned. Supporting illustrations may be used to enhance the explanation.

5.2.4.2 Access information work package <accessinfowp>. A WP shall be developed containing information for gaining access to the aircraft wiring bundle assemblies. Illustrations providing access door locations and access areas where bundle assemblies are routed shall be

## MIL-STD-3001-5A(AS)

included. These access doors and areas shall be keyed to the wire bundle assembly routing WPs by WP number (see [figure 6](#)). When necessary, an introduction <intro> may be included.

5.2.4.3 Wire bundle assembly routing work packages <bunroutewp>. The routing of each individual aircraft wiring bundle shall be provided. A WP shall be developed for each aircraft wiring bundle. When necessary, an introduction <intro> may be included. Each WP shall contain an illustration showing the routing of the bundle within the aircraft (see [figure 7](#)). When applicable, a legend shall be included reflecting specific aircraft effectivities and associated usable on codes. All connectors that are a part of the bundle shall be illustrated along with the attaching hardware, including clamps, straps, grommets, markers, etc. As applicable, critical and noncritical clamping shall be identified. Each part on the illustration shall be assigned an index number. A parts list <bunroutepl> (see [figure 8](#)) (**standard table**) comprised of the below listed entries shall accompany the illustration:

- a. Index number.
- b. Part number.
- c. Description of the part.
- d. Units per assembly.
- e. Usable on code.
- f. SM&R code.

5.2.5 Required aircraft wiring connector repair information. Repair (maintenance) procedures shall be developed for all aircraft wiring system components. Connectors, backshells, wires, cables, and harness assemblies (bundles) which remain in the aircraft after the removal of all avionics, engines, and ordnance equipment (e.g., pylons, bomb racks, etc.) are considered wiring system components. Wiring system components are classified as either standard or aircraft specific components. Standard components are those that have been assigned a military type part number or designation. Aircraft specific components are those designed and developed specifically for the aircraft and have been assigned an aircraft manufacturer's part number.

5.2.5.1 Development of aircraft wire connector repair work packages. Repair procedure WPs ([5.2.5.7](#) and [5.2.5.8](#)) shall not be developed for standard wiring system components when the repair procedures are provided in NAVAIR 01-1A-505, Installation Practices for Aircraft Electric and Electronic Wiring. When the repair instructions for a standard aircraft wiring component are not covered in the NAVAIR 01-1A-505 series manual, the repair WPs described in [5.2.5.7](#) through [5.2.5.8](#) shall be developed, as applicable. These WPs shall be removed from the aircraft manual when the NAVAIR 01-1A-505 series manual is updated to include these repair procedures. When necessary, an introduction <intro> may be included. Repair procedures and other types of wire repair connector information shall be included in the following types of WPs:

## MIL-STD-3001-5A(AS)

- a. Wiring systems repair identification and information WP.
- b. Wiring system component repair tool list WP (**standard military type components only**).
- c. Dedicated aircraft specific wiring systems repair kit WP.
- d. Wire type list WP.
- e. Wiring systems connector repair tools WP.
- f. Wiring systems connector component repair WPs.
- g. Aircraft cable assembly parts data WP.

5.2.5.2 Wiring systems repair identification and information work package <wrepidwp>. An explanation of how the aircraft wiring system repair information is identified and defined shall be included in this WP. The heading "WIRING SYSTEMS REPAIR IDENTIFICATION AND INFORMATION" shall appear in the title block of this WP. The WP shall include the following elements, as applicable:

- a. Introduction <intro>. A general explanation of the intent and contents of this WP.
- b. Reference designator system. An explanation of the aircraft reference designator system.
- c. Electrical connector identification. An explanation of how all aircraft electrical connectors are identified. Supporting illustrations may be used to enhance the explanation.
- d. Splice area identification. An explanation of how all aircraft wiring splice areas are identified. Supporting illustrations may be used to enhance the explanation.
- e. Ground point identification. An explanation of how all aircraft ground points are identified. Supporting illustrations may be used to enhance the explanation.
- f. Individual wire identification. An explanation of how all aircraft individual wires are identified. Supporting illustrations may be used to enhance the explanation.

5.2.5.3 Wiring system component repair tool list work package <compreplistwp> (standard military type components only). A WP shall be developed containing a list <compreplist> of all insert, extraction, and crimping tools used to repair the standard military type wiring components. The heading "STANDARD MILITARY COMPONENT REPAIR TOOL LIST" shall appear in the title block of the WP. Components shall be listed by part number in alphanumeric order. For each part number listed, the part number of the insert, extraction, and crimping tools, as applicable, shall be provided along with a reference to the NAVAIR 01-1A-505 series manuals. If the repair procedures are not contained in the NAVAIR 01-1A-505

## MIL-STD-3001-5A(AS)

series manuals, a reference to the applicable repair WP within the wiring connector repair manual shall be included.

5.2.5.4 Aircraft specific wiring systems repair kit work package <reprkitwp>. All tools, contained in a tool kit, used for repair of aircraft specific components shall be included in this WP. The heading "WIRE/CONNECTOR REPAIR TOOL KITS" shall appear in the title block of this WP. The tool kits shall be illustrated and each tool that comprises the kit shall be listed <reprkitlist> by part number and nomenclature and located on the illustration.

5.2.5.5 Wire type list work package <wtypelistwp>. A list <wtypelist> (**standard list**) of wire type numbers assigned to simplify wire type references throughout the wire system repair WPs shall be provided in this WP. The heading "WIRE TYPE LIST" shall appear in the title block of this WP. The entries described below shall be provided for each wire type. When additional information is required for any of the following entries, a use-on-code/symbol may be placed in the listing to refer to the introduction of the WP which shall contain the applicable note(s) identified by the same use-on-code/symbol (see [figure 9](#)):

- a. Wire type code. The wire type identifying number shall be listed in numerical or alphanumerical order. The technique may vary from equipment manufacturer to equipment manufacturer. A combination of characters and numbers or numbers only may be used. If the manufacturer does not use a wire type code, the wire type shall be listed by part number.
- b. Wire gage. The gage of the wire type shall be listed.
- c. Part number. The alphanumeric part number of the wire type shall be listed.
- d. Wire stripper. The part number of the applicable stripper tool used for the wire type shall be listed. The MIL SPEC wire stripper number shall be used unless the wire stripper required is for an aircraft specific application.
- e. Wire/cable description. A brief, accurate, description of the wire type (e.g., single conductor, stranded, silver-coated copper, chromel and alumel, thermocouple twisted, shielded, jacketed, etc.). Abbreviate as necessary.

5.2.5.6 Aircraft specific repair tools work package <reptoolwp>. Procedures for the use of aircraft specific tools needed for wiring or connector repair shall be developed. A WP shall be developed for each type of tool. The heading "WIRING SYSTEMS REPAIR TOOLS" followed by the part number and nomenclature of the tool shall appear in the title block of this WP. Each WP shall include the following information, as applicable:

- a. A general description of the tool and its purpose.
- b. Procedures, supported by graphics, addressing the component parts of the tool and their assembly.



## MIL-STD-3001-5A(AS)

- c. Procedures, supported by graphics, addressing the adjustment of the component parts of the tool (e.g., blades for the coaxial cable stripper).
- d. Go-no-go gage inspection procedures, supported by graphics, for the tool.
- e. Additional data such as stripping tool versus wire type, etc.

5.2.5.7 Wiring system connector component repair work packages <wcomprepwp>. WPs shall be developed for the repair (maintenance) of all aircraft specific wiring system components. When the repair instructions for a standard military type aircraft wiring system component are not covered in the NAVAIR 01-1A-505 series manual, the repair WPs described in [5.2.5.7.1](#) through [5.2.5.7.8](#) shall be developed, as applicable. The title block for each component repair WP shall include the nomenclature for the specific type of component. Each WP may contain an introduction <intro> and a brief description <wiringcompdesc> of the component (connector accessories, their function, and availability by connector series as governed by applicable Military Specifications and Standards) and shall include all maintenance procedures <maintproc> required to repair the aircraft wiring systems component. Maintenance procedures shall be developed for the aircraft wiring systems components listed below:

- a. Single conductor nonshielded wires.
- b. Thermocouple wires.
- c. Single conductor shielded cables.
- d. Multi-conductor shielded cables.
- e. Coaxial cables.
- f. Triaxial cables.
- g. Filter line cables.
- h. Shielded/nonshielded, overbraided wiring harnesses.
- i. Shielded cable splice terminations.
- j. Splice combination and end caps.
- k. Solder sleeve installations.
- l. Electrical components sealing.
- m. Peculiar wiring system components.

## MIL-STD-3001-5A(AS)

The below listed types of aircraft wiring system components may require additional maintenance data as described in [5.2.5.7.1](#) through [5.2.5.7.8](#):

- a. Terminals, ring tongue crimped barrel installation.
- b. Shielded terminal ferrules (high temperature).
- c. Electrical cable assemblies sealing.
- d. Circular and rectangular connectors.
- e. Single contact and triaxial connectors.
- f. Protective boot installation for environmental type connectors with metal or molded plastic cable clamps.
- g. Fabrication of shielded harness terminated with electromagnetic interference backshells.
- h. Silicone rubber tape boots.

**5.2.5.7.1 Terminals, ring tongue crimped barrel installation.** In addition to the technical content requirements described in [5.2.5.7](#), the WP for this type of component shall include terminal crimping data. The terminal crimping data shall be listed in reference designator order. The following entries shall be included:

- a. REF DES.
- b. CONTACT.
- c. TERMINAL PART NUMBER.
- d. CRIMP TOOL PART NUMBER.
- e. "TOOL CASE LOCATION" with the "TOOL" identification number and "DIE" identification number listed.
- f. DIE PART NUMBER.
- g. STRIP LENGTH.
- h. EFFECTIVITY.

**5.2.5.7.2 Shielded terminal ferrules (high temperature).** In addition to the technical content requirements described in [5.2.5.7](#), the WP for this type of component shall include detailed procedures to explain the tool/wire/terminal ferrule relationship to eliminate any possibility of confusion. It shall also include information on ferrule and die set combinations. A list in ferrule

## MIL-STD-3001-5A(AS)

part number alphabetical order shall be included that contains the entries "FERRULE PART NUMBER," "INSULATION DIAMETER," "DIE SET PART NUMBER," and "DIE SET COLOR CODE."

**5.2.5.7.3 Electrical cable assemblies sealing.** In addition to the technical content requirements described in [5.2.5.7](#), the WP for this type of component shall include procedures and supporting illustrations that provide sealing techniques for wire bundles passing through bulkheads. Any EMI wire bundle sealing techniques shall also be included.

**5.2.5.7.4 Circular and rectangular connectors.** In addition to the technical content requirements described in [5.2.5.7](#), the WP for this type of component may include repair procedures for different types of circular connectors having different types of part numbers (e.g., D38999/26KC98P, MS27473T14B97P, and LJT06RB97P). Nevertheless, all belong to the same family and may be included in a single WP, unless for clarity it would make more sense to divide the repair procedures into separate WPs. This WP division may be made by connector series I, II, III, or IV. The WP shall include the following additional information:

- a. A general description of the connector type(s) and a breakdown of military and/or vendor part numbering system for the connector, including polarization information.
- b. Corrosion control information, repair procedures and wire preparation information.
- c. Reference to the WP(s) that contains the procedures on the use of crimp tools, stripping tools, and the go-no-go gages for inspecting crimp tools.
- d. The illustrations developed for each connector family shall adhere to the following guidelines:

(1) All connector part numbers within the same WP having the same insert configuration and contact part number(s) shall only be illustrated once. For circular connectors having more than one size or type of contact, the illustration of the insert configuration shall reflect the difference in contact size using different size circles with the contact identifier enclosed within the circle. It is important to note that connector keying (polarization) is immaterial in this application and is not directly relevant to connector repair. Also, wire number/letter identifiers to insert configurations (pin outs) are not applicable to connector repair procedures.

(2) Each figure for each connector part number shall include all necessary information in three separate tables. The first table shall be a reference designator to backshell data index. The second table shall be for tool data. The third table shall be for contact data.

(3) Two additional tables apply for connectors having coaxial and/or shielded contacts. The first is for tool data for coaxial (or shielded) contact. The second is for contact data for coaxial (or shielded) contact. In addition, detailed assembly instructions are required when either coaxial/shielded, thermocouple, or unusually terminated contacts are involved. All dimensions used shall be stated in fractions with appropriate tolerances.

## MIL-STD-3001-5A(AS)

5.2.5.7.5 Single contact and triaxial connectors. In addition to the technical content requirements described in [5.2.5.7](#), the WP for this type of component shall include a brief description of the connectors including their type and part number. The WP shall also include the following additional information:

- a. Corrosion control information, repair procedures and wire preparation information.
- b. Reference to the WP(s) that contains the procedures on the use of soldering tools, crimp tools, stripping tools, and the go-no-go gages for inspecting crimp tools.
- c. Detailed cable preparation and assembly (build-up) instructions for each style of connector covered. All dimensions used shall be stated in fractions with appropriate tolerances.

5.2.5.7.6 Protective boot installation for environmental type connectors with metal or molded plastic cable clamps. In addition to the technical content requirements described in [5.2.5.7](#), the WP for this type of component shall include the following technical information:

- a. BT adapter tools. Illustrations shall be developed for each tool and include dimensional information. Directly below the tool shall be a breakdown of the military and/or vendor part numbering system.
- b. Adapter tool/connector mating. An illustration shall be included showing the relationship between the tool and connector.
- c. Strap wrench set-up, adjustment, and operation. Procedures describing the use of the wrench shall be included. Supporting illustrations shall be used to clarify the procedures.
- d. Tie wrap tools (**connectors with molded plastic cable clamps only**). Procedures for the use of tie wraps and the tie wrap tool to secure cable clamps to harness assemblies shall be included.
- e. Disassembly and assembly procedures. Procedures to disassemble and assemble the cable clamp from the connector shall be provided.
- f. For connectors with metal cable clamps, cable clamp part numbers versus spacer part numbers shall be provided.
- g. Tape information in tape part number order shall be listed. The width (**for metal cable clamps only**) and Commercial and Government Entity (CAGE) code shall also be listed. A brief description of tape wrapping procedures shall accompany the listing.
- h. An illustration shall be included for each backshell part number covered in the WP. Each illustration shall include the following backshell information entries:

MIL-STD-3001-5A(AS)

- (1) REFERENCE DESIGNATION.
- (2) BACKSHELL PART NUMBER.
- (3) REFERENCE WORK PACKAGE.
- (4) TOOL PART NUMBER.
- (5) TOOL CASE NUMBER.

i. For environmental type connectors with molded plastic cable clamps, an illustration shall be included showing the plastic tie down straps used. Each illustration shall include the following tie down strap information entries:

- (1) STRAP PART NUMBER.
- (2) CAGE.
- (3) HARNESS DIAMETER (inch).

5.2.5.7.7 Fabrication of shielded harness terminated with electromagnetic interference backshells. In addition to the technical content requirements described in [5.2.5.7](#), the WP for this type of component shall include the following technical information:

- a. BT adapter tools. Illustrations shall be developed for each tool and include dimensional information. Directly below the tool shall be a breakdown of the military and/or vendor part numbering system.
- b. Adapter tool/connector mating. An illustration shall be included showing the relationship between the tool and connector.
- c. Strap wrench set-up, adjustment, and operation. Procedures describing the use of the wrench shall be included. Supporting illustrations shall be used to clarify the procedures.
- d. Tie wrap tools. Procedures for the use of tie wraps and the tie wrap tool to secure cable clamps to harness assemblies shall be included.
- e. Disassembly and assembly procedures. Procedures to disassemble and assemble the cable clamp from the connector shall be provided.
- f. Tape information in tape part number order shall be listed. The CAGE code shall also be listed. A brief description of tape wrapping procedures shall accompany the listing.
- g. An illustration shall be included for each backshell part number covered in the WP. Each illustration shall include the following backshell information entries:

## MIL-STD-3001-5A(AS)

- (1) REFERENCE DESIGNATION.
- (2) BACKSHELL PART NUMBER.
- (3) REFERENCE WORK PACKAGE.
- (4) TOOL PART NUMBER.
- (5) TOOL CASE NUMBER.

h. An illustration shall be included showing the plastic tie down straps used. Each illustration shall include the following tie down strap information entries:

- (1) STRAP PART NUMBER.
- (2) LENGTH (inch).
- (3) CONNECTOR SHELL SIZE.
- (4) TOOL TENSION SETTING.
- (5) MILITARY SPECIFICATION.

5.2.5.7.8 Silicone rubber tape boots. In addition to the technical content requirements described in [5.2.5.7](#), the WP for this type of component shall include procedures outlining the methods to be used to repair damaged silicone boots. Appropriate references shall be made to wire and/or cable repair WPs in the event wire or cable damage exists under the damaged boot. Information about the silicone rubber tape shall include the tape part number, its CAGE code, and the width of the tape in inches.

5.2.5.8 Aircraft cable assembly parts data work package <partswp>. A WP containing parts data <partdata> shall be developed for each cable assembly. An introduction shall be included when necessary to explain aircraft effectivities, usable on codes, and any required notes. Cable assembly parts shall be listed (**standard table**) by REFERENCE DESIGNATION in alphanumeric order. For each reference designation listed, the following data shall be provided (see [figure 10](#)):

- a. PART NUMBER.
- b. DESCRIPTION and CAGE.
- c. QUANTITY.
- d. USE ON CODE.
- e. SM&R CODE.

MIL-STD-3001-5A(AS)

f. CLK DEG.

g. NOTES.

**6. NOTES**

The notes in Section 6 of MIL-STD-3001-1 apply to this Part.

## MIL-STD-3001-5A(AS)

CIRCUIT FUNCTION LETTER	CIRCUIT	EXAMPLES
A	Armament	Stores Management System Missiles/Rockets Gun Chemical
B	Photographic	Camera Camera Doors Camera Heating
C	Control Surface	Autopilot Flight Control Wing Sweep Trim Control Airbrakes Hydraulic System
D	Instrument (other than flight or engine instruments)	Position Indicator Pressure Gauge Temperature Gauge Clock
E	Engine Instrument	Temperature Gauge Pressure Gauge Quantity Meter Flow Meter Tachometer Power Indicator Nozzle Indicator
F	Flight Instrument	Gyroscopic Instrument Attitude Indicator Compass Head Up Display Altitude
G	Landing Gear Wing Folding	Extension and Retraction Braking Locking Steering Anti-Skid Arrestor Hook Utilities Hydraulics

FIGURE 1. Example of aircraft wiring systems circuit identification.



## MIL-STD-3001-5A(AS)

CIRCUIT FUNCTION LETTER	CIRCUIT	EXAMPLES
H	Heating Ventilating and De-icing	Heating De-icing Cabin conditioning Galley Equipment Bay Cooling
I	In order to avoid confusion with the numeral one, the letter "I" shall not be used for circuit or cable identification.	
J	Ignition	Engine Ignition Jet-Assisted Take-Off
K	Engine Control	Vent and Flap Propeller Control Carburetor Supercharging Power Control Nozzle Control Thrust Reverser Engine Starting
L	Lighting (Illumination)	Internal External
M	Miscellaneous (Electrical)	Windshield Wiper & Spray Doors Hoist and Winch Position (Seat & Pedal) Auxiliary Power Unit Emergency Power Unit Cigarette Lighter
N	Unassigned	
O	In order to avoid confusion with the numeral zero, the letter "O" shall not be used for circuit or cable identification.	
P	DC Power	Generation Distribution Battery Rectifier External Power
Q	Fuel and Oil	Valves Pumps Refueling/Defueling Transfer Dump

FIGURE 1. Example of aircraft wiring systems circuit identification - Continued.

## MIL-STD-3001-5A(AS)

CIRCUIT FUNCTION LETTER	CIRCUIT	EXAMPLES
R	Radio (Navigational and Communication)	Instrument Landing Homing Liaison Marker Beacon VHF Radio UHF Radio HF Radio Intercommunication Direction Finding
S	Radar (Pulse Technique)	Radar Altimeter Interception Gun Aiming Mapping Navigation Bomb Aiming Search Recognition (IFF) Terrain Following
T	Special Electronics	Active Electronic Counter Inertial Navigation Television Measures Reconnaissance Computer Weapon Aiming Chaff Dispensing Infra-Red
U	Miscellaneous (Electronic)	Electronic wiring for which the "R," "S" or "T" identification is not applicable shall be assigned the circuit function letter "U." An example would be common leads to electronic equipments and systems, inter-connection wiring, such as antenna or power circuits common to more than one equipment.
V	Both DC power cables and DC control cables for AC systems shall be identified by the circuit function letter "V."	
W	Warning and Emergency (except those listed under other circuit functions)	Bail-Out Alarm Oxygen Indicator Passenger Sign Central/Master Warning

FIGURE 1. Example of aircraft wiring systems circuit identification - Continued.

## MIL-STD-3001-5A(AS)

CIRCUIT FUNCTION LETTER	CIRCUIT	EXAMPLES
X	AC Power	Generation Distribution ExternalPower
Y	Armament Special Equipment (except those listed under circuit function "A")	
Z	Experimental Circuits. When flight test and experimental research wiring is installed, the appropriate Circuit Function Letter shall be used, preceded by the letter "Z." When any such circuit has been adopted and becomes part of a standard installation, the letter "Z" shall be removed.	

FIGURE 1. Example of aircraft wiring systems circuit identification - Continued.

MIL-STD-3001-5A(AS)

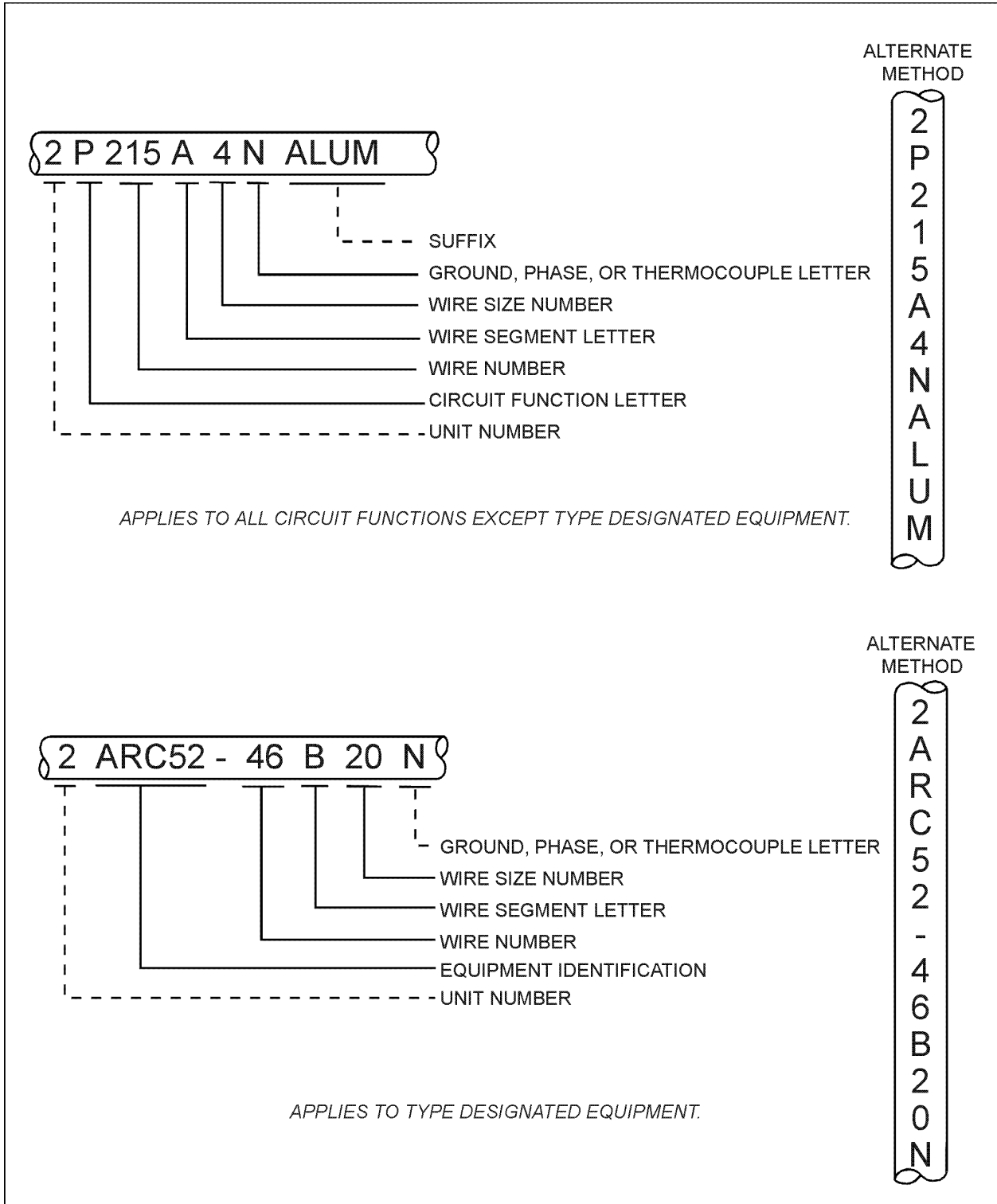

FIGURE 2. Example of wire identification.

## MIL-STD-3001-5A(AS)

WIRE NUMBER	WIRING DIAGRAM	WIRE HARNESS	FROM		TO		LENGTH FT.-IN.
			ITEM	PIN	ITEM	PIN	
W539- 119 -22	103.20	A15 - E5539 - 1	300P38	34	TB16	6B	16 — 10
W539- 120 -22	103.20	A15 - E5539 - 1	300P38	35	300J20	61	18 — 4
W539- 121 -22	103.20	A15 - E5539 - 1	300P38	37	300J20	50	18 — 4
W539- 122 -22	103.20	A15 - E5539 - 1	300P38	38	300J20	51	18 — 4
W539- 123 -22	103.20	A15 - E5539 - 1	300P38	39	300J20	52	18 — 4
W539- 124 -22	103.20	A15 - E5539 - 1	300P38	40	TB16	4F	16 — 10
W539- 125 -22	103.20	A15 - E5539 - 1	300P38	41	TB16	2H	16 — 10
W539- 126 -22	103.20	A15 - E5539 - 1	300P38	42	TB16	5K	16 — 10
W539- 127 -22	103.20	A15 - E5539 - 1	300P38	43	300J20	53	18 — 4
W539- 128 -22	103.20	A15 - E5539 - 1	300P38	44	300J20	54	18 — 4
W539- 129 -22	103.20	A15 - E5539 - 1	300P38	45	300J20	55	18 — 4
W539- 130 -22	103.20	A15 - E5539 - 1	300P38	46	300P 8	27	19 — 6
W539- 131 -20	104.10	A15 - E5539 - 1	300P32	41	300J 2	3	12 — 5
W539- 132 -20	104.10	A15 - E5539 - 1	300P32	42	300J 2	26	12 — 5
W539- 133 -20	104.10	A15 - E5539 - 1	300P34	36	300J 2	28	12 — 5
W539- 134 -20	104.10	A15 - E5539 - 1	SM0003		300J 6	18	7 — 2
W539- 135 -20	104.10	A15 - E5539 - 1	300P10	6	SM000		4 — 6
W539- 136 -22	104.10	A15 - E5539 - 1	SM0003		300J 14	41	12 — 7
W539- 137 -20	104.10	A15 - E5539 - 1	300P32	43	SP0024		6 — 10
W539- 138 -20	105.10	A15 - E5539 - 1	300P10	38	300J 6	15	9 — 6
W539- 139 -20	105.10	A15 - E5539 - 1	300P10	39	300J 6	16	9 — 6
W539- 140 -20	105.10	A15 - E5539 - 1	300P32	24	300P 8	30	19 — 6
W539- 141 -20	105.10	A15 - E5539 - 1	300P32	25	300P 8	29	19 — 6
W539- 142 -20	105.10	A15 - E5539 - 1	300P32	26	300P 8	31	19 — 6
W539- 143 -20	105.10	A15 - E5539 - 1	300P32	27	300P 8	32	19 — 6
W539- 144 -20	105.10	A15 - E5539 - 1	300P32	28	300P 8	6	19 — 6
W539- 145 -22	111.10	A15 - E5539 - 1	300P32	29	300J 2	4	12 — 5
W539- 146-22	112.10	A15 - E5539 - 1	300P10	40	TB16	10H	20 —
W539- 147-22	113.10	A15 - E5539 - 1	300P34	13	300J 2	55	12 — 5
W539- 148-22	119.10	A15 - E5539 - 1	300P32	30	300 J2	5	12 — 5
W539- 149-20	121.10	A15 - E5539 - 1	300J 4	48	TB203	4	24 —
W539- 150-20	121.11	A15 - E5539 - 1	TB17	1	300J22	33	6 — 6
W539- 151-20	121.11	A15 - E5539 - 1	TB17	2	300J22	34	6 — 7
W539- 152-20	121.11	A15 - E5539 - 1	TB17	3	300J22	35	6 — 8
W539- 153-20	121.11	A15 - E5539 - 1	TB17	4	300J22	36	6 — 9
W539- 154-20	121.11	A15 - E5539 - 1	300P10	7	300J14	16	16 — 2

FIGURE 3. Example of an aircraft wire run list.

## MIL-STD-3001-5A(AS)

EQUIPMENT REF. DES.	PIN	WIRE IDENTIFICATION	WIRE HARNESS	EQUIPMENT REF. DES.	PIN	WIRING DIAGRAM	
066P 4	A	W557-GD116 D20N	A15-E5557-001	GD116 ACH2	—	066.10	
	B	W557- 110-22	A15-E5557-001	066 S 1	=A14	066.10	
	C	W557- 340-22-RED	A15-E5557-001	TB 9	13F	066.12	
	D	W557- 341-22-BLU	A15-E5557-001	TB 9	14F	066.12	
	J	W557- 92-22	A15-E5557-001	TB 8	10A	067.10	
	K	W557- 88-22	A15-E5557-001	TB 8	8K	067.10	
	L	W557- 343-22-BLU	A15-E5557-001	TB11	12F	066.12	
	M	W557- 342-22-RED	A15-E5557-001	TB11	12A	066.12	
	P	W557- 28-22	A15-E5557-001	066P 2	C	066.10	
	R	W557- 29-22	A15-E5557-001	066P 2	D	066.10	
	S	W557- 339-22-BLU	A15-E5557-001	TB 9	12F	066.12	
	T	W557- 338-22-RED	A15-E5557-001	TB 9	12A	066.12	
	U	W557- 91-22	A15-E5557-001	TB 8	9F	067.10	
	V	W557- 87-22	A15-E5557-001	TB 8	8D	067.10	
	W	W557- 93-22	A15-E5557-001	TB 8	10G	067.10	
	X	W557- 89-22	A15-E5557-001	TB 8	7G	067.10	
	Y	W557- 90-22	A15-E5557-001	TB 8	9B	067.10	
	Z	W557- 86-22	A15-E5557-001	TB 8	8A	067.10	
	A-	W557- 11-22-RED	A15-E5557-001	066S 1	=A15	066.10	
	B-	W557- 12-22-BLU	A15-E5557-001	066S 1	=B18	066.10	
	C-	W557- 13-22-YEL	A15-E5557-001	066S 1	=B17	066.10	
	D-	W557- 25-22-RED	A15-E5557-001	066S 1	=A18	066.10	
	E-	W557- 27-22-YEL	A15-E5557-001	066S 1	=A17	066.10	
	F-	W557- 26-22-BLU	A15-E5557-001	066S 1	=A16	066.10	
	G-	W557- GD150 B20N	A15-E5557-001	GD150 ACL2		121.10	
	H-	W557- 202-20	A15-E5557-001	TB225	3D	121.10	
	J-	W557-141-22	A15-E5557-001	066S 1	=B16	066.10	
	066P 5	A	W557- 30 —22	A15-E5557-001	066J 8	A	066.10
		C	W557- 39 —22	A15-E5557-001	066J 8	C	066.10
		G	W557- 34 —22	A15-E5557-001	066J 8	G	066.10
H		W557- 35 —22	A15-E5557-001	066J 8	H	066.10	
J		W557- 40 —22	A15-E5557-001	066J 8	J	066.10	
K		W557- 42—22	A15-E5557-001	066J 8	K	066.10	
L		W557- 41—22	A15-E5557-001	066J 8	L	066.10	
M		W557- 31 —22	A15-E5557-001	066J 8	M	066.10	

FIGURE 4. Example of a wiring reference designation list.

## MIL-STD-3001-5A(AS)

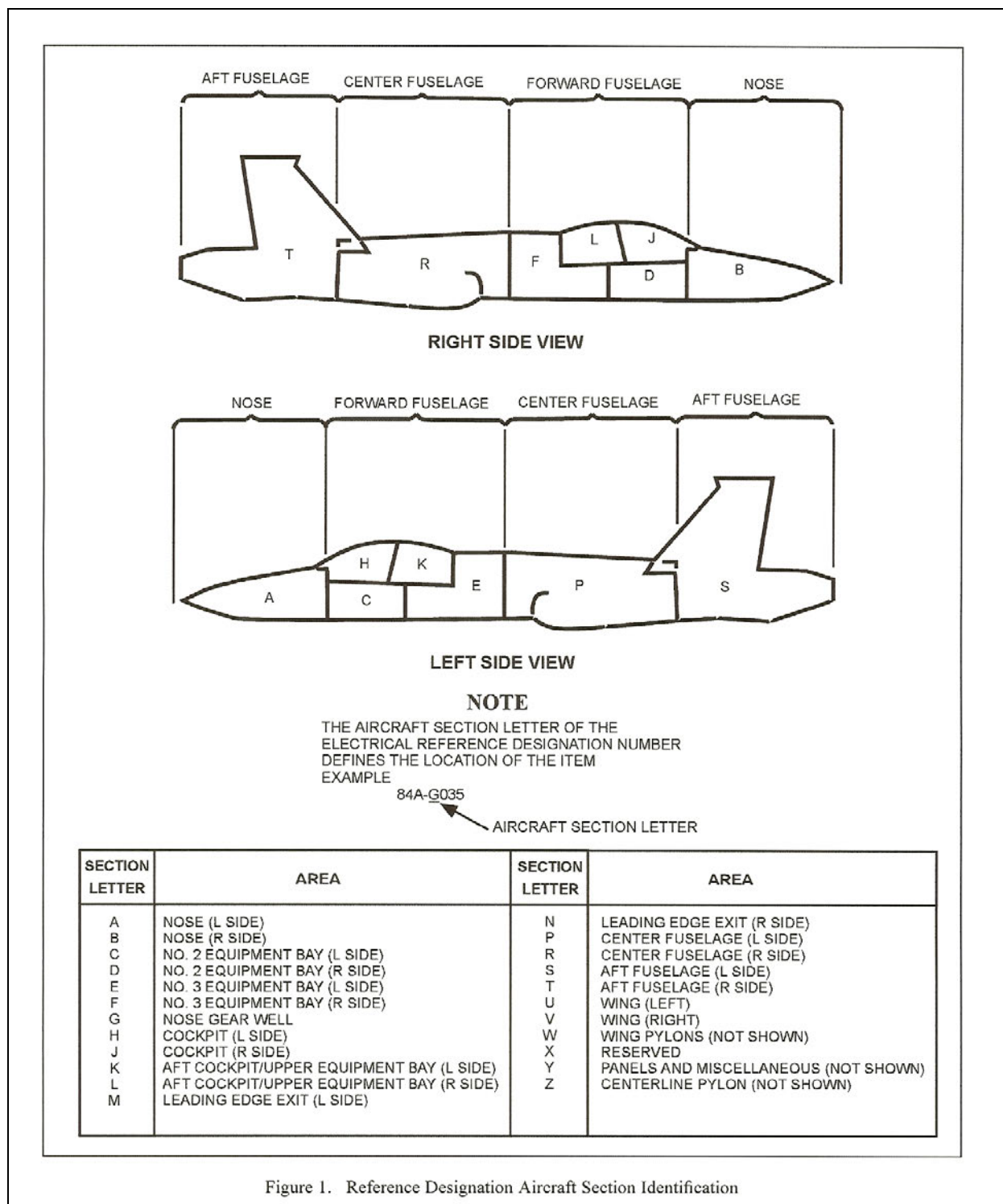

Figure 1. Reference Designation Aircraft Section Identification

FIGURE 5. Example of a reference designation aircraft section identification.

# MIL-STD-3001-5A(AS)

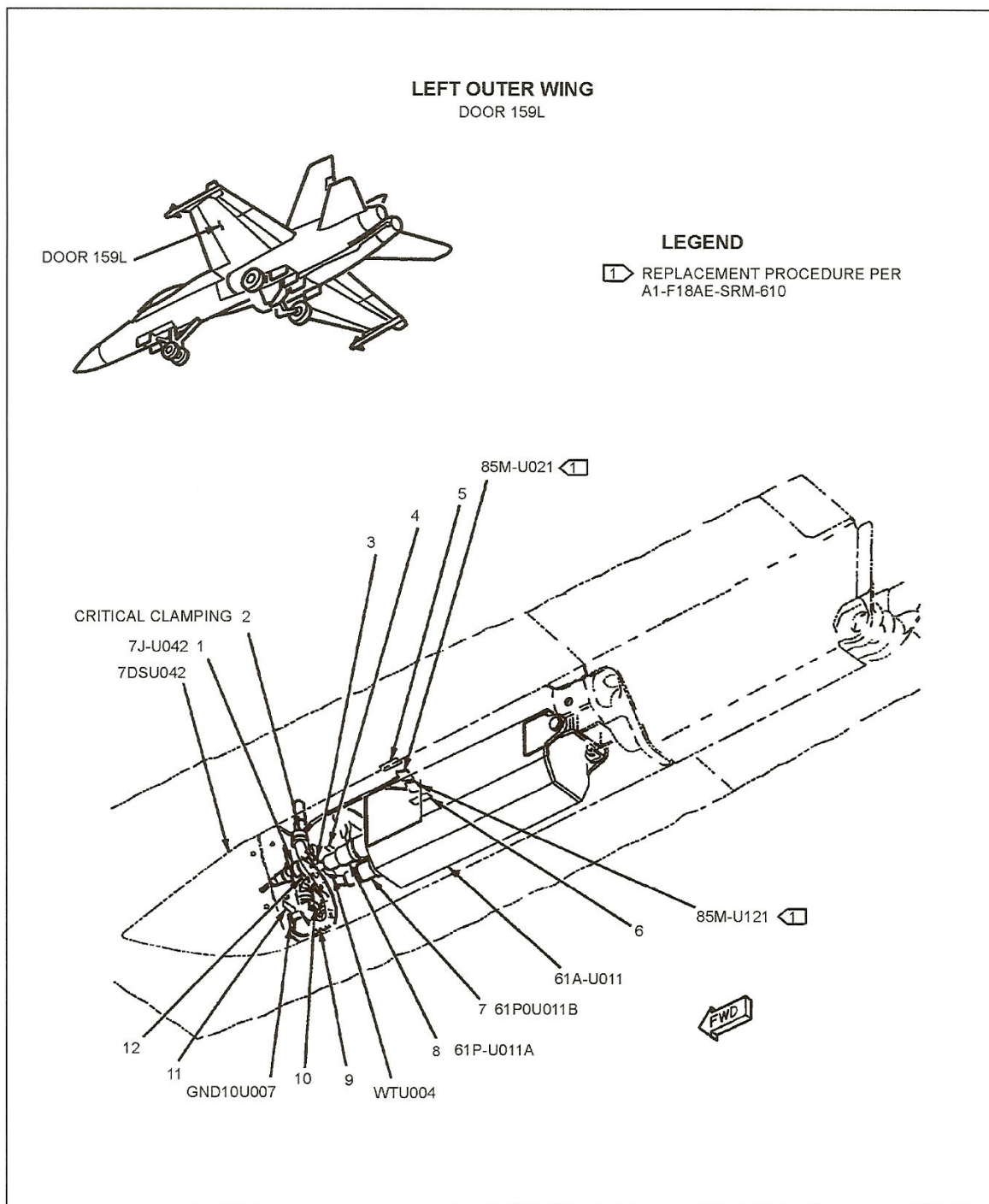

FIGURE 5. Example of a reference designation aircraft section identification - Continued.



## MIL-STD-3001-5A(AS)

AREA LOCATION BY ACCESS DOOR		
AREA/DOOR NO.	INDEX NO.	WORK PACKAGE NO.
Cheek Area - L Center Fuselage	145	L701 00, L702 00
Cheek Area - R Center Fuselage	155	L707 00, L708 00
Cockpit	36	L400 00 thru L412 00
Inner Wing - Left	24	L900 00 thru L908 00
Inner Wing - Right	84	L950 00 thru L958 00
Main Landing Gear - Left	146	L717 00, L718 00
Main Landing Gear - Right	129	L729 00, L730 00
Main Landing Gear Wheelwell Area - Left	171	L719 00 thru L727 00
Main Landing Gear Wheelwell Area - Right	126	L731 00 thru L738 00
Navigation Light Access	77	L221 00
Nose Gear	32	L305 00, L306 00
Nose Wheelwell Area	139	L116 00, L217 00, L307 00 thru L313 00
Speed Brake	21	L822 00, L823 00, L825 00
Upper Equipment Bay	37	L500 00 thru L502 00
Vertical Stabilizer - Left	19	L830 00 thru L833 00
Vertical Stabilizer - Right	8	L826 00 thru L829 00
Door 1	34	L025 00
Door 3	140	L001 00 thru L004 00, L008 00, L009 00, L025 00, L026 00, L027 00
Door 4	35	L005 00
Door 7L	39	L300 00, L301 00
Door 7R	72	L300 00, L301 00
Door 9	33	L115 00
Door 10L	142	L100 00 thru L107 00
Door 10R	158	L200 00 thru L207 00
Door 11L	141	L115 00
Door 11R	159	L216 00
Door 12L	169	L700 00
Door 12R	132	L709 00
Door 13L	143	L108 00 thru L111 00
Door 13R	157	L208 00 thru L211 00
Door 14L	144	L112 00 thru L114 01
Door 14R	156	L212 00 thru L215 00
Door 16	163	L314 00 thru L317 00

FIGURE 6. Example of an access door and area location list.

## MIL-STD-3001-5A(AS)

AREA LOCATION BY ACCESS DOOR		
AREA/DOOR NO.	INDEX NO.	WORK PACKAGE NO.
Door 17L	38	L300 00, L301 00
Door 17R	73	L300 00, L301 00
Door 18	41	L302 00, L303 00, L304 00
Door 22	31	L119 00
Door 23	72	L220 00
Door 25L	138	L117 00
Door 25R	180	L218 00
Door 26	42	L607 00
Door 27	165	L701 00 thru L704 00, L707 00, L708 00
Door 29L	30	L600 00
Door 29R	78	L612 00
Door 30L	137	L117 00
Door 30R	161	L218 00
Door 31	43	L608 00
Door 32L	29	L600 00, L601 00
Door 32R	80	L613 00
Door 33	164	L314 00 thru L317 00
Door 34L	26	L601 00, L602 00
Door 34R	81	L614 00, L952 00
Door 35L	136	L118 00
Door 35R	162	L219 00

FIGURE 6. Example of an access door and area location list - Continued.

MIL-STD-3001-5A(AS)

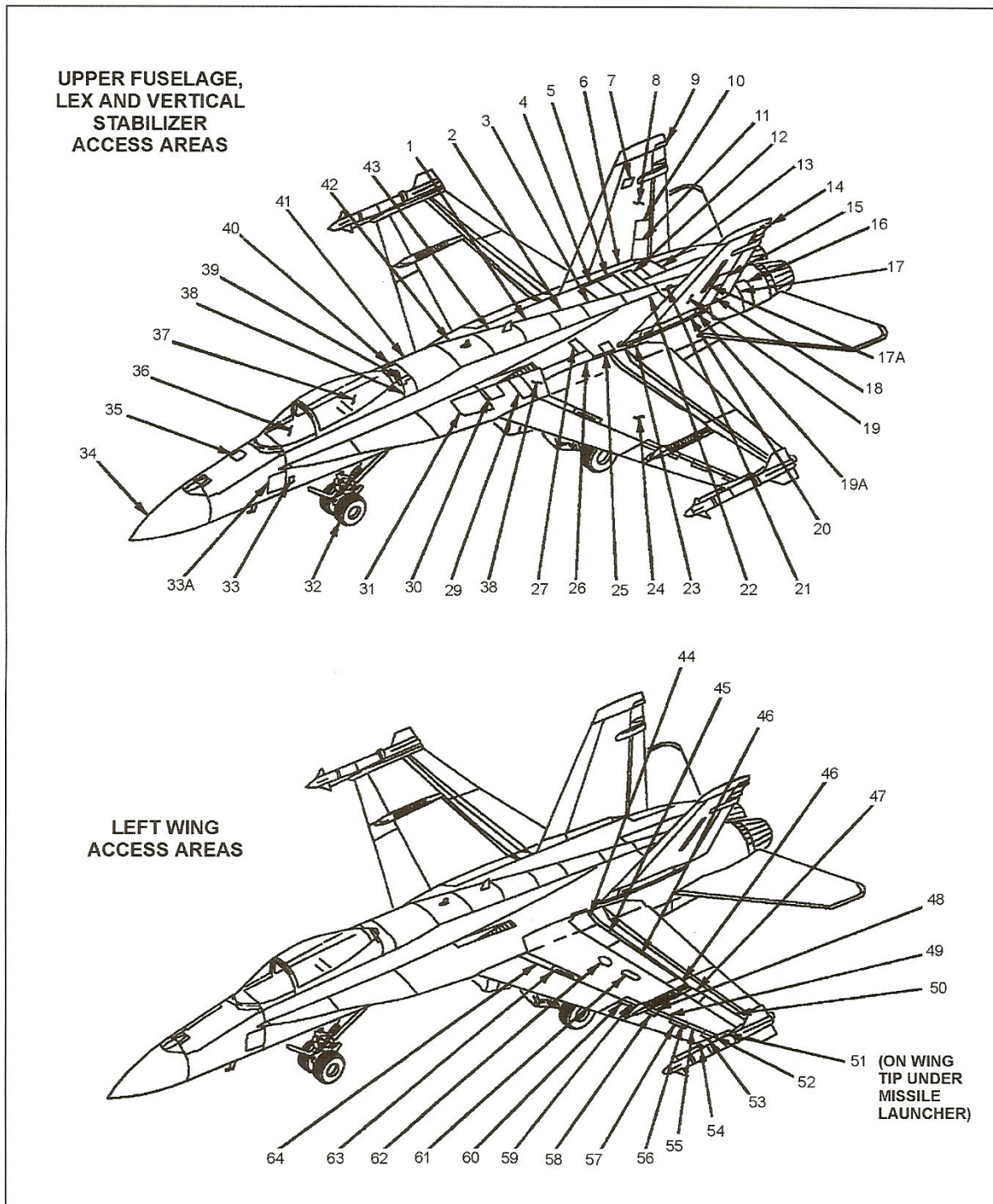

FIGURE 6. Example of an access door and area location list - Continued.

MIL-STD-3001-5A(AS)

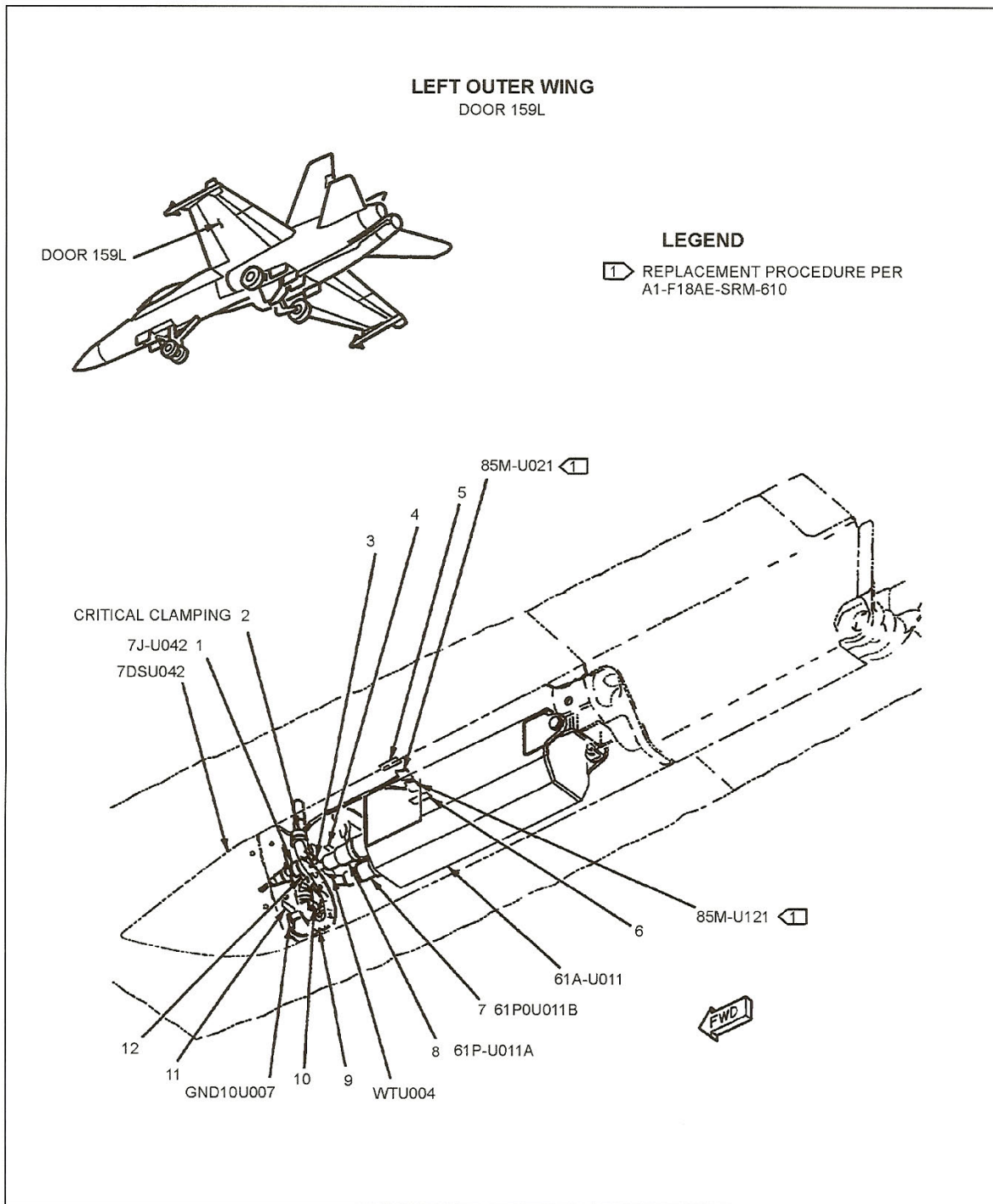

FIGURE 7. Example of aircraft wire bundle routing.

## MIL-STD-3001-5A(AS)

INDEX NO.	PART NUMBER	DESCRIPTION	UNITS							USABLE ON CODE	SM&R CODE
			PER ASSY	1	2	3	4	5	6		
1	MS27656T9B98S	CONNECTOR, RECEPTACLE /7J - U042/.....	1								PAOZZ
	NAS600 - 8P	SCREW (AP).....	4								PAOZZ
	NAS1149DN416J	WASHER (AP).....	4						*		PAOZZ
	AN960JD4L	WASHER (AP).....	4						*		PAOZZ
2	MS21919WDG #	CLAMP.....	1								—
	NAS673V #	BOLT (AP).....	1								—
	NAS1149DO316J	WASHER (AP).....	1						*		PAOZZ
	AN960JD10LL	WASHER (AP).....	1						*		PAOZZ
3	MS21919WDG #	CLAMP.....	1								—
4	74A890601 - 2241	MARKER, IDENTIFICATION - ELECTRICAL /76301/ /WTU004/.....	1								MGOZZ
5	74A890601 - 2951	MARKER, IDENTIFICATION - ELECTRICAL /76301/ 85M - U021/.....	1								MGOZZ
6	74A890601 - 2952	MARKER, IDENTIFICATION - ELECTRICAL /76301/ 85M - U121/.....	1								MGOZZ
7	MS27467T13B35S	CONNECTOR, PLUG /61P - U011B/.....	1								PAOZZ
8	MS27467T13B35SD	CONNECTOR, PLUG /61P - U011A/.....	1								PAOZZ
9	MS21919WDG #	CLAMP /61P - U011B/.....	1								—
	NAS673V17 #	BOLT (AP).....	1								PAOZZ
	NAS1149DO316J	WASHER (AP).....	1						*		PAOZZ
	AN960JD10LL	WASHER (AP).....	1						*		PAOZZ
	NAS42DD6 - 55	SPACER (AP).....	1								PAOZZ
	MS21042L3	NUT (AP).....	1								PAOZZ
10	MS21919WDG #	CLAMP.....	1								—
11	74A890601 - 2837	MARKER, IDENTIFICATION - ELECTRICAL /76301/ /GND10U007/.....	1								MGOZZ
12	74A890601 - 2429	MARKER, IDENTIFICATION - ELECTRICAL /76301/ /7J-U042/.....	2								MGOZZ

**NOTES**

1. # LENGTH / SIZE TO BE DETERMINED AT INSTALLATION.
2. \* ALTERNATE OR EQUIVALENT PARTS. (INTRO)

FIGURE 8. Example of an aircraft wire bundle parts list.

## MIL-STD-3001-5A(AS)

WIRE TYPE CODE	WIRE GAGE	PART NUMBER	WIRE STRIPPER	WIRE/CABLE DESCRIPTION
167	12 16 20 22	M22759/11-12-4 M22759/11-16-6 M22759/11-20-2 M22759/11-22-5	45-1501 45-1600 45-1500 45-1500	Single Conductor, Stranded Silver, Coated Copper
260		QQW343		Single Conductor, Solid, Tin Coated Copper
339		M17/174-00001	45-164	Coaxial Cable
381	12 16 20 22	M22759/7-12-4 M22759/7-16-6 M22759/7-20-2 M22759/7-22-5	45-1501 45-1500 45-1500 45-1500	Single Conductor, Stranded Silver, Coated Copper
637	22	M5846-1E2/22		Chromel and Alumel, Thermocouple Twisted, Shielded and Jacketed
638		M17/172-00001	45-162	Coaxial Cable
644	16 20 22	M27500-16SP2U14 M27500-20SP2U14 M27500-22SP2U14	45-1633 45-1633 45-1633	2 Conductor, Stranded Copper, Twisted
645	16 20 22	M27500-16SP3U14 M27500-20SP3U14 M27500-22SP3U14	45-1633 45-1633 45-1633	3 Conductor, Stranded Copper, Twisted
646	16 20 22	M27500-16SP4U14 M27500-20SP4U14 M27500-22SP4U14	45-1633 45-1633 45-1633	4 Conductor, Stranded Copper, Twisted

FIGURE 9. Example of a wire type list.

## MIL-STD-3001-5A(AS)

REFERENCE DESIGNATION	PART NUMBER	DESCRIPTION	(CAGE)	QTY	USE ON CODE	SM&R CODE	CLK DEG	N O T E
	74A750301-9CPD	CABLE ASSEMBLY	76301	1	AA	XBOOO		
	74A750301-9FAA	CABLE ASSEMBLY	76301	1	AH	XBOOO		
	74A750301-9FDA	CABLE ASSEMBLY	76301	1	AO	XBOOO		
	74A750301-9FHA	CABLE ASSEMBLY	76301	1	AR	XBOOO		
	74A750301-9FKA	CABLE ASSEMBLY	76301	1	AT	XBOOO		
	74A750301-9FRA	CABLE ASSEMBLY	76301	1	AW	XBOOO		
	74A750301-9FVA	CABLE ASSEMBLY	76301	1	AY	XBOOO		
	74A750301-9JAA	CABLE ASSEMBLY	76301	1	BA	XBOOO		
1P-H004	MS27467T15B35SB	. CONNECTOR, PLUG		1		PAOZZ	335	
	74A890600-3679	. BAND MARKER	76301	1		MDOZZ		
	5M2920-1DW	. BACKSHELL	76301	1		—		
	5M2920-1DW	. SWITCH		REF		—		
12CBH003	—	. CKT BRKR		REF		—		
12P-H008	MS27467T15B35S	. CONNECTOR, PLUG		1		PAOZZ	200	
	74A890600-3685	. BAND MARKER	76301	1		MDOZZ		
	5M2920-1DW	. BACKSHELL	76301	1		—		
15J-K006	M25516/19-02-04	. CONNECTOR		1	AC	PAOZZ		
	74A890600-3686	. BAND MARKER	76301	1	AC	MDOZZ		
15J-K007	M25516/19-03-04	. CONNECTOR		1	AC	PAOZZ		
	74A890600-3687	. BAND MARKER	76301	1	AC	MDOZZ		
15P-H002	165-62	. CONNECTOR, PLUG (76301 SPEC 5M3062)	02660	1	AC	PAOZZ	180	A
	74A890600-3688	. BAND MARKER	76301	1	AC	MDOZZ		
15P-H015	MS27467T13B98S	. CONNECTOR, PLUG		1	AQ	PAOZZ	90	A
	74A890600-4311	. BAND MARKER	76301	1	AQ	MDOZZ		
	5M2920-1CW	. BACKSHELL	76301	1	AQ	—		
15P-K010	165-14-1000	. CONNECTOR, PLUG (76301 SPEC 5M30-14-1000)	02660	1	AC	PAOZZ		A
	74A890600-3717	. BAND MARKER	76301	1	AC	MDOZZ		
18CBH001	—	. CKT BRKR		REF		—		
22J-K171	MS27656T11B35S	. CONNECTOR		1	AQ	PAOZZ	195	
	74A890600-4216	. CONNECTOR		1	AC	PAOZZ	240	
	MS27656T11B35S	. BAND MARKER	76301	1		MDOZZ		

FIGURE 10. Example of cable assembly repair parts data.

## MIL-STD-3001-5A(AS)

REFERENCE DESIGNATION	PART NUMBER	DESCRIPTION	(CAGE)	QTY	USE ON CODE	SM&R CODE	CLK DEG	N O T E
	1009-12	. PLATE, RETAINING (76301 SPEC ST3M546B3)	04967	1	*	PAOZZ		
	FSC/MD-12A0106	. PLATE, RETAINING (76301 SPEC ST3M546B3)	04967	1	*	PAOZZ		
	AT340-12	. PLATE, RETAINING (0A554) (76301 SPEC ST3M546B3)		1	*	PAOZZ		
	S935-12A	. PLATE, RETAINING (76301 SPEC ST3M546B3)	19904	1	*	PAOZZ		
	5M2920-1BW	. BACKSHELL	76301	1		—		
22P-H069	MS27467T11B35S	. CONNECTOR, PLUG		1		PAOZZ	340	
	74A890600-3690	. BAND MARKER	76301	1		MDOZZ		
	5M2920-1BW	. BACKSHELL	76301	1		—		
22P-K114	MS27467T11B35S	. CONNECTOR, PLUG		1		PAOZZ	0	
	74A890600-3725	. BAND MARKER	76301	1		MDOZZ		
	5M2920-1BW	. BACKSHELL	76301	1		—		

FIGURE 10. Example of cable assembly repair parts data - Continued.



MIL-STD-3001-5A(AS)

CONCLUDING MATERIAL

Custodian:  
Navy - AS

Preparing activity:  
Navy - AS  
(Project TMSS-2014-018)

NOTE: The activity listed above was interested in this document as of the date of this document. Since organizations and responsibilities can change, you should verify the currency of the information above using the ASSIST Online database at <https://assist.dla.mil>.