

NOT MEASUREMENT  
SENSITIVE

MIL-STD-3001-4A(AS)  
10 October 2014  
SUPERSEDING  
MIL-STD-3001-4(AS)  
15 May 2001

# DEPARTMENT OF DEFENSE STANDARD PRACTICE

DIGITAL TECHNICAL INFORMATION  
FOR  
MULTI-OUTPUT PRESENTATION  
OF  
TECHNICAL MANUALS

MAINTENANCE INFORMATION WITH  
ILLUSTRATED PARTS BREAKDOWN (IPB)  
(PART 4 OF 8 PARTS)



AMSC N/A

AREA TMSS

DISTRIBUTION STATEMENT A. Approved for public release; distribution is unlimited.

## MIL-STD-3001-4A(AS)

**FOREWORD**

1. This standard is approved for use by the Department of the Navy and is available for use by all Departments and Agencies of the Department of Defense.

2. This eight-part standard establishes the requirements needed to prepare digital technical information for multi-output presentation of NAVAIR work package (WP) Technical Manuals (TMs). The technical content and mandatory style and format requirements contained in this eight-part standard can be used to develop and assemble complete TMs for aircraft weapon systems, aeronautical equipment, airborne weapons/equipment, and support equipment WP TMs. The requirements are applicable for the output of printed paper and PDF screen displayed TMs. The requirements are also applicable for the display of Interactive Electronic Technical Manuals (IETMs) on any viewer that supports MIL-STD-3001-1.

3. MIL-STD-3001-4 is Part 4 of eight parts and is incomplete without Parts 1 through 3 and Parts 5 through 8. Part 4 establishes the technical content requirements for the preparation of maintenance information with illustrated parts breakdown (IPB) for aircraft weapon systems, aeronautical equipment, airborne weapons/equipment, and support equipment. This data can be used to develop TMs in a variety of output forms, including interactive screen presentations and page-based printed and PDF screen displayed TMs.

4. MIL-STD-3001-1 contains general preparation requirements for the multi-output presentation of NAVAIR WP TMs. MIL-STD-3001-2 through MIL-STD-3001-8 contain specific functional technical content requirements for the preparation of all NAVAIR WP TMs and revisions. Parts 1 through 8 are identified below:

|                |  |
|----------------|--|
| MIL-STD-3001-1 | Preparation of Digital Technical Information for Multi-output Presentation of Technical Manuals. |
| MIL-STD-3001-2 | Description, Principles of Operation, and Operation Data.  |
| MIL-STD-3001-3 | Testing and Troubleshooting Procedures.  |
| MIL-STD-3001-4 | Maintenance Information with Illustrated Parts Breakdown (IPB).                                  |
| MIL-STD-3001-5 | Aircraft Wiring Information.   |
| MIL-STD-3001-6 | Structural Repair Information.   |
| MIL-STD-3001-7 | Periodic Maintenance Requirements.   |
| MIL-STD-3001-8 | Separate Illustrated Parts Breakdown (IPB).  |

5. Comments, suggestions, or questions on this document should be addressed to the Naval Air Systems Command (Commander, Naval Air Warfare Center Aircraft Division, Code 412000B120-3, Highway 547, Lakehurst, NJ 08733-5100) or emailed to [michael.sikora@navy.mil](mailto:michael.sikora@navy.mil). Since contact information can change, you may want to verify the currency of this address information using the ASSIST online database at <https://assist.dla.mil>.

## MIL-STD-3001-4A(AS)

## CONTENTS

| <u>PARAGRAPH</u>   | <u>PAGE</u> |
|--|-------------|
| <b>FOREWORD</b> .....  | ii          |
| <b>1. SCOPE</b> .....  | 1           |
| 1.1 Scope.....   | 1           |
| <b>2. APPLICABLE DOCUMENTS</b> .....   | 1           |
| <b>3. DEFINITIONS</b> .....  | 1           |
| <b>4. GENERAL REQUIREMENTS</b> .....   | 1           |
| 4.1 General.....   | 1           |
| 4.2 Maintenance level applicability.....   | 1           |
| 4.3 Selective application and tailoring.....   | 1           |
| 4.4 Preparation of digital data for electronic delivery.....   | 1           |
| 4.4.1 Use of the DTDs.....   | 2           |
| 4.5 Technical content.....   | 2           |
| 4.5.1 Types of work packages.....  | 2           |
| 4.5.2 Style and format requirements.....   | 2           |
| 4.6 Standard tables and lists.....   | 2           |
| 4.7 Electrostatic discharge (ESD) sensitive equipment.....   | 2           |
| 4.8 Nuclear hardness.....  | 2           |
| 4.9 Ozone depleting substances (ODS).....  | 3           |
| 4.10 Special processes.....  | 3           |
| <b>5. DETAILED REQUIREMENTS</b> .....  | 3           |
| 5.1 Preparation of maintenance information with IPB.....   | 3           |
| 5.2 Work package content.....  | 3           |
| 5.2.1 Title block <titleblk>.....  | 3           |
| 5.2.2 Work package information <wpinfo>.....   | 3           |
| 5.2.2.1 Reference material list <reflist>.....   | 3           |
| 5.2.2.2 Record of Applicable Technical Directives <ratd>.....  | 4           |
| 5.2.2.3 Support equipment required list <selist>.....  | 5           |
| 5.2.2.4 Facilities required list <faclist>.....  | 6           |
| 5.2.2.5 Materials required list <matlist>.....   | 6           |
| 5.3 Required maintenance information with IPB.....   | 6           |
| 5.3.1 Maintenance work packages <maintwp>.....   | 7           |
| 5.3.1.1 Maintenance tasks.....   | 8           |
| 5.3.1.1.1 Maintenance task requirements.....   | 10          |
| 5.3.1.1.2 Preparation for use and assembly.....  | 11          |
| 5.3.1.1.3 Handling.....  | 11          |
| 5.3.1.1.3.1 Handling <handling>.....   | 11          |
| 5.3.1.1.3.2 Handling (engines, aeronautical equipment, airborne weapons/equipment, and support equipment)..... | 12          |
| 5.3.1.1.4 Removal.....   | 12          |
| 5.3.1.1.5 Disassembly.....   | 13          |
| 5.3.1.1.6 Cleaning and corrosion control.....  | 13          |
| 5.3.1.1.7 Inspection.....  | 13          |
| 5.3.1.1.8 Repair.....  | 14          |
| 5.3.1.1.9 Assembly.....  | 14          |

## MIL-STD-3001-4A(AS)

## CONTENTS

| <u>PARAGRAPH</u>  | <u>PAGE</u> |
|---|-------------|
| 5.3.1.1.10 Test and inspection.....   | 15          |
| 5.3.1.1.11 Installation.....  | 15          |
| 5.3.1.1.12 Calibration.....   | 15          |
| 5.3.1.1.13 Preparation for storage or shipment .....  | 15          |
| 5.3.1.1.14 Safety information <safe>.....   | 16          |
| 5.3.1.1.15 Engine start and run-up <engstart>.....  | 16          |
| 5.3.1.1.16 Fabrication.....   | 17          |
| 5.3.2 General maintenance procedures work package <genmaintwp>.....   | 17          |
| 5.3.3 Servicing work package <servicewp> ( <b>General Aircraft Information, Plane Captain's, or Line Maintenance Manual only</b> ).....         | 17          |
| 5.3.4 Ground operations work package <grndopwp> ( <b>General Aircraft Information, Plane Captain's, or Line Maintenance, Manual only</b> )..... | 17          |
| 5.3.5 Support equipment maintenance work package <semaintwp>.....   | 17          |
| 5.3.6 Local manufacturing and assembly work package <locmfgwp>.....   | 18          |
| 5.3.7 Power plant build-up work packages .....  | 18          |
| 5.3.7.1 General information work package <geninfomaintwp>.....  | 18          |
| 5.3.7.2 Quick Engine Change Kit (QECK) description work package <qeckdescwp> .....  | 18          |
| 5.3.7.3 Quick Engine Change Assembly (QECA) work packages <qecawp> .....  | 18          |
| 5.3.7.4 Non-Quick Engine Change Assembly (non-QECA) work packages <nonqecawp> .....   | 18          |
| 5.3.7.5 Additional power plant build-up work packages <bldupwp>.....  | 18          |
| 5.3.8 Pre-induction and mandatory inspection work package ( <b>engines only</b> ) <preindinswp> .....   | 18          |
| 5.3.9 External tubing, cabling, and clamping work packages ( <b>engines only</b> ).....   | 19          |
| 5.3.9.1 Numerical index work package <compindwp> .....  | 19          |
| 5.3.9.2 Bracket installation work package <brktwp> .....  | 19          |
| 5.3.9.3 External components work package <extcompwp>.....   | 19          |
| 5.3.9.4 External tubing, cabling, and clamping installation work package <extubwp>.....   | 19          |
| 5.3.9.4.1 Zone references .....   | 20          |
| 5.3.9.4.2 Zone detail views.....  | 20          |
| 5.3.9.5 Critical clearances work package <critclwp>.....  | 20          |
| 5.3.10 Sequence control chart ( <b>engines only</b> ).....  | 20          |
| 5.3.10.1 Upper portion SCC.....   | 20          |
| 5.3.10.2 Middle portion of SCC.....   | 20          |
| 5.3.10.3 Lower portion SCC .....  | 21          |
| 5.3.11 Illustrated parts breakdown data (IPB) <ipbwp>.....  | 21          |
| 5.3.11.1 IPB data prepared as an integral part of the maintenance tasks <ipb> .....   | 21          |
| 5.3.11.1.1 Index numbers .....  | 22          |
| 5.3.11.1.1.1 Index numbers for attaching parts .....  | 22          |
| 5.3.11.1.1.2 Part numbers.....  | 22          |
| 5.3.11.1.1.3 Description .....  | 26          |
| 5.3.11.1.1.4 Units per assembly .....   | 31          |
| 5.3.11.1.1.5 Usable on code .....   | 31          |
| 5.3.11.1.1.6 SM&R code.....   | 32          |
| 5.3.11.1.1.7 Work unit code (WUC).....  | 32          |
| 5.3.11.1.1.8 Detailed IPB technical content requirements .....  | 32          |
| 5.3.11.1.1.8.1 Nuclear hardness critical items [HCI] .....  | 32          |
| 5.3.11.1.1.8.2 Electrostatic discharge (ESD) sensitive parts.....   | 33          |
| 5.3.11.1.1.8.3 Index numbers on illustrations .....   | 33          |

## MIL-STD-3001-4A(AS)

## CONTENTS

| <u>PARAGRAPH</u>   | <u>PAGE</u> |
|--|-------------|
| 5.3.11.1.8.4 Attaching parts on illustrations.....                               | 33          |
| 5.3.11.1.8.5 Indexing assemblies .....   | 33          |
| 5.3.11.1.8.6 Items not having a logical maintenance sequence.....                | 33          |
| 5.3.11.1.8.7 Component boards.....   | 33          |
| 5.3.11.1.8.8 Polarity identification .....                                       | 34          |
| 5.3.11.1.8.9 Reference designations.....   | 34          |
| 5.3.11.2 Separate IPB work packages <ipbwp> (for paged-based manuals only) ..... | 34          |
| 5.3.11.2.1 IPB work package content.....   | 34          |
| 5.3.12 Wiring/cabling diagram work packages <wirediawp> .....                    | 34          |
| 5.3.13 Wire run lists work packages <wirelistwp> .....                           | 34          |
| 6. NOTES.....  | 34          |

| <u>FIGURES</u>  | <u>PAGE</u> |
|---|-------------|
| FIGURE 1. Example of task-oriented maintenance with IPB work package. ....                          | 35          |
| FIGURE 2. Example of inspection procedures.....   | 39          |
| FIGURE 3. Example of a dimensional calculation worksheet. ....                                      | 40          |
| FIGURE 4. Example of location of part number and serial number for service life limited items. .... | 41          |
| FIGURE 5. Example of dimensional data. ....   | 42          |
| FIGURE 6. Example of a local manufacturing and assembly work package.....                           | 43          |
| FIGURE 7. Example of a power plant build-up work package. ....                                      | 45          |
| FIGURE 8. Example of a probable cause / corrective action table.....                                | 49          |
| FIGURE 9. Example of a mandatory/recommended maintenance tasks table. ....                          | 50          |
| FIGURE 10. Example of a numerical index work package.....   | 51          |
| FIGURE 11. Example of a bracket installation. ....  | 52          |
| FIGURE 12. Example of external tubing, cabling, and clamping installation.....                      | 54          |
| FIGURE 13. Example of critical clearances.....  | 59          |
| FIGURE 14. Example of sequence control chart.....   | 60          |

## MIL-STD-3001-4A(AS)

## 1. SCOPE

1.1 Scope. This part of the standard establishes the technical content requirements for the preparation of maintenance information with illustrated parts breakdown (IPB) for aircraft weapon systems, aeronautical equipment, airborne weapons/equipment, and support equipment. This data can be used to develop TMs in a variety of output forms, including interactive screen presentations and page-based printed and screen displayed PDF TMs.

## 2. APPLICABLE DOCUMENTS

The applicable documents in Section 2 of MIL-STD-3001-1 apply to this Part.

## 3. DEFINITIONS

The definitions in Section 3 of MIL-STD-3001-1 apply to this Part.

## 4. GENERAL REQUIREMENTS

4.1 General. Sufficient maintenance information with IPB shall be developed for the aircraft weapon system, aeronautical equipment, airborne weapons/equipment or support equipment. Maintenance procedures and supporting illustrations shall be prepared so that maintenance personnel can perform all authorized operator through depot level maintenance. This information shall be contained in Maintenance Information Modules that are subdivided into WPs.

4.2 Maintenance level applicability. Requirements contained in this Part are applicable to all types and maintenance levels of TMs unless specifically noted in bold and in parentheses (i.e., **Support Equipment Manuals only, Depot Level only**, etc.).

4.3 Selective application and tailoring. This Part contains some requirements that may not be applicable to the preparation of all TMs. Selective application and tailoring of requirements contained in this Part shall be accomplished through the use of the Technical Manual Content Selection Matrixes contained in MIL-STD-3001-1, Appendix A. The applicability of some requirements is also designated by one of the following statements: unless specified otherwise by the requiring activity or as/when specified by the requiring activity.

4.4 Preparation of digital data for electronic delivery. TM data prepared and delivered digitally in accordance with this Part of the standard shall be XML-tagged and assembled using the modular Document Type Definition (DTD). Refer to MIL-STD-3001-1 for information on obtaining or accessing this modular DTD. XML tags used in the modular DTD are noted throughout the text of this Part in bracketed, bold characters (i.e., **<maintim>**) as a convenience for the TM author and to denote the appropriate tag to be used for this specific information when developing a document instance.

## MIL-STD-3001-4A(AS)

4.4.1 Use of the DTDs. The modular DTDs referenced in this Part interpret the technical content and structure for the functional requirements contained in this Part and are mandatory for use.

4.5 Technical content. Technical content requirements contained in this Part are considered mandatory and are intended for compliance. The content structure for the technical data being developed shall conform to the associated modular Document Type Definition (DTD) for maintenance information with Illustrated Parts Breakdown (IPB).

4.5.1 Types of work packages. There are basically two types of WPs. The first type is an information-oriented WP. It provides information such as general information about the printed TM or the IETM and specific information about the weapon system/equipment, such as principles of operation and operating instructions. The second type of WP is task-oriented. Task-oriented WPs reflect all required maintenance tasks, including testing and troubleshooting, at the assigned level of maintenance. Task-oriented WPs also contain supporting information such as required materials and support equipment required for each defined task. WPs are written to reflect the engineering design, Logistics Support Analysis (LSA) or Logistics Management Information (LMI), Level of Repair Analysis (LORA), approved maintenance plan, and the established repair concept (SM&R Codes).

4.5.2 Style and format requirements. For mandatory style and format requirements for WP technical manuals intended for a printed, page-oriented presentation, refer to MIL-STD-3001-1, Appendix B. For style and format requirements for the on-screen display of IETMs, refer to NAVAIRINST 4120.11, Policy for Preparation and Standardization of NAVAIR Interactive Electronic Technical Manuals (IETMs).

4.6 Standard tables and lists. Standard tables and lists are noted throughout the text of this standard in bold and in parentheses (i.e., **(standard table)**, **(standard list)**). The structure and titles of the column headings for these standard tables and lists shall have no deviations.

4.7 Electrostatic discharge (ESD) sensitive equipment. If the electronic equipment to be handled, inspected, repaired, or assembled is ESD sensitive, the [ESD] icon and the symbol [ESD] shall be incorporated into the applicable tasks and procedures of the technical publications to ensure that ESD sensitive parts are not degraded during handling or operation. The [ESD] icon shall precede the procedure title. The specific step(s) in the procedure addressing handling or operation which could damage ESD sensitive parts shall be labeled by placing the symbol [ESD] between the step number and the text.

4.8 Nuclear hardness. If the weapon system/equipment to be operated, maintained or overhauled has nuclear survivability requirements (e.g., overpressure and burst, thermal radiation, electromagnetic pulse (EMP), or transient radiation effects on electronics (TREE)), applicable warnings and Hardness-Critical Processes (HCP) symbols shall be incorporated into the applicable tasks and procedures of the technical publications to ensure the hardness of the equipment is not degraded during handling or operation. Caution shall be taken not to include classified information in an unclassified publication. When entire paragraphs, including subparagraphs, are considered hardness critical, only major paragraphs shall be marked. The

## MIL-STD-3001-4A(AS)

appropriate symbol [HCP], [HCI], [OCP], [OCI], [CSP], or [CSI] shall be placed between the paragraph number and title. When only certain processes/steps within a paragraph are hardness critical, only the applicable process/step shall be marked. The symbol (HCP), [HCI], [OCP], [OCI], [CSP], or [CSI] shall be placed between the step number and text. For the definitions of the acronyms contained in this paragraph, refer to Section 3 of MIL-STD-3001-1.

4.9 Ozone depleting substances (ODS). The continued use of ODS has been prohibited by Executive Order 12856. The use of ODS materials in NAVAIR manuals is prohibited. A listing of these substances will be provided by the requiring activity.

4.10 Special processes. Information shall be included for any special process required under extreme environmental or operational conditions within the limits of the equipment.

## 5. DETAILED REQUIREMENTS.

5.1 Preparation of maintenance information with IPB. Maintenance information shall be developed and contained in maintenance information modules <maintim>. These maintenance information modules shall be logically subdivided into task-oriented WPs to enable a technician to receive, process, test, and maintain the weapon system/equipment and associated components in accordance with the established maintenance concept (see [figure 1](#)).

5.2 Work package content. Each WP developed for maintenance information with IPB shall consist of the following:

- a. Title block.
- b. WP information.
- c. Required maintenance information with IPB.

5.2.1 Title block <titleblk>. For page-based TMs, refer to MIL-STD-3001-1, Appendix B, for WP title block content requirements. For IETMs, refer to MIL-STD-3001-1, Appendix C.

5.2.2 Work package information <wpinfo>. Each WP developed for maintenance information with IPB shall begin with a reference material list, a record of applicable technical directives (TDs), a support equipment required list, a facilities required list, and a materials required list, if applicable.

5.2.2.1 Reference material list <reflist>. Reference material required to complete a task or discussion within a WP shall be contained in a reference material list (**standard list**). If no reference material applies, the heading "Reference Material" shall be omitted from the WP. Guidelines for developing the reference material list are provided below:

- a. Only those publications required for performance of the task covered by the WP shall be included in the reference material list.



## MIL-STD-3001-4A(AS)

b. Publications such as guides or standards which are not directly needed to accomplish the task (backup informational material or bibliography) shall not be listed in the reference material list even if cited in the WP text.

c. Each entry in the list shall consist of:

(1) A title. Reference publications within the WP by title. If the reference is to a specific WP, the WP title shall be listed below the related publication title.

(2) A number. The appropriate publication or WP number.

d. The maintenance level of publications listed is not required.

e. Referenced publications shall be presented by title in alphabetical order. The publication title, WP title, and WP number shall also be identified. When two or more WPs are referenced in the same manual, they shall be listed in numerical sequence; repetition of the manual title and publication number is not required.

f. Additional WPs within the same manual that are required to complete the task or discussion shall be presented first in numerical sequence. The WP title and WP number shall also be identified. The publication number is not required.

g. Referenced publications not prepared in WP format shall be presented in numerical sequence. The title and publication number shall also be included.

5.2.2.2 Record of Applicable Technical Directives <ratd>. Technical directives applicable to a specific WP shall be listed in a record of applicable technical directives list (**standard list**). If no technical directives apply, the heading "Record of Applicable Technical Directives" shall be omitted from the WP. The record of technical directives shall be prepared in accordance with the following guidelines:

a. All issued technical directives having any impact on the WP shall be listed upon incorporation into the WP.

b. Approved engineering change proposals (ECPs) that have no effect on retrofit of the end item shall not be listed in the record of applicable technical directives (e.g., "no technical directive will be issued").

c. All technical directives and related ECPs or Rapid Action Minor Engineering Changes (RAMECs) shall be listed upon incorporation into the WP.

(1) "TD Type/No." - Enter the type and number of the technical directive, e.g., "F/A-18 AFC 126" or "AVC 102." Note: The "TD Type/No." is identified on the Change Control Board (CCB) formal letter of ECP or RAMEC approval. Refer to NAVAIR 00-25-300, Naval Air Systems Command Technical Directives System.

## MIL-STD-3001-4A(AS)

(2) "TD Date" - Enter the date of issue of the technical directive. If the number of the technical directive has been assigned but the directive has not been issued, a dash (-) shall be entered.

(3) "Title and ECP/RAMEC No." - The title of the technical directive and the ECP number or RAMEC, if applicable, shall be listed. If a technical directive listed is the direct result of an approved ECP or RAMEC, the acronym ECP or RAMEC and number shall be shown in parentheses following the technical directive title.

(4) "Date Inc." - The date the information affected by the technical directive or the ECP was incorporated into the WP.

(a) If the technical directive number has been assigned and the directive has not yet been issued (retrofit program), but the ECP that incorporates the change in the production program has been approved, the production ECP coverage shall be included, and the notation "Production coverage only" shall be entered under "Remarks."

(b) When the retrofit TD is approved and incorporated in a change or revision following the incorporation of the production ECP coverage, the TD date of issue shall be entered under "TD Date," the notation "Production coverage only" shall be removed from under "Remarks," and the date of retrofit coverage incorporation shall be listed under "Date Inc." (in lieu of the production ECP coverage incorporation date).

(5) "Remarks" - Enter any applicable remarks.

5.2.2.3 Support equipment required list <selist>. All support equipment (SE), including special tools required to perform operational type procedures, shall be listed (**standard list**) immediately following the record of applicable technical directive data. If no support equipment is required, the heading "Support Equipment Required" shall be omitted from the WP. Only those special tools (including torque wrenches) and equipment authorized for use at the level of maintenance covered shall be listed. Items shall be listed in alphabetical sequence by noun nomenclature. Standard hand tools shall not be listed. Illustrations shall not be prepared in support of such lists. When the manual is used by other services or commands that require usage restrictions, the item shall be identified by a symbol following the part number in parentheses. The usage of the symbol shall be explained in a notation (e.g., "(AF)=USAF only," "(NS)=NAVSEA only," "(MC)=MARINE CORPS only").

5.2.2.3.1 Each support equipment entry in the list shall be identified by "Nomenclature," "Part Number," and "CAGE (Commercial and Government Entity) Code." When more than one of the same item is required, the quantity shall follow the nomenclature in parentheses. If a "CAGE Code" is not available, a dash shall be substituted for the "CAGE Code".

5.2.2.3.2 If the WP contains multilevel maintenance procedures and any of the SE items are authorized for use at only certain level(s), the restrictive use shall be indicated by the use of an O, I, and/or D in parentheses following the item nomenclature. For **Aircraft Engine Manuals** the following special application codes to identify usage restrictions shall be used:

## MIL-STD-3001-4A(AS)

- a. "J" shall be used to indicate the first degree engine maintenance level,
- b. "8" shall be used to indicate the second degree engine maintenance level, and
- c. "9" shall be used to indicate the third degree engine maintenance.

5.2.2.4 Facilities required list <faclist>. All facilities needed to accomplish the maintenance procedures shall be listed (**standard list**) immediately following the support equipment required list. If no facilities are required, the heading "Facilities Required" shall be omitted from the WP. Each facilities entry in the list shall be identified by "Nomenclature," "Part Number," and "CAGE Code."

5.2.2.5 Materials required list <matlist>. All materials (consumable materials and/or expendable items) required to perform maintenance type procedures shall be listed (**standard list**). If no materials apply, the heading "Materials Required" shall be omitted from the WP. Items should be listed in alphabetical sequence by noun nomenclature. The materials required list shall be prepared in accordance with the following guidelines. If the material is a hazard material, the hazard material warning summary (HMWS) shall be included.

- a. Each material entry in the list shall be identified by "Nomenclature," "Specification/Part Number," and "HMWS Index Number," as applicable.

- (1) Unless alternate identification is approved by the requiring activity, materials shall be listed by Government specification.

- (2) If the WP contains multilevel maintenance procedures and any of the materials are authorized for use at only certain level(s), the restriction shall be indicated by the use of an O, I, and/or D in parentheses following the item nomenclature.

- (3) When more than one of the same item is required, the quantity shall follow the nomenclature in parentheses.

- b. Parts that require mandatory replacement (e.g., preformed packing) in the procedure shall be listed.

- c. An appropriate notation shall follow the item to explain each restriction and/or quantity requirement.

5.3 Required maintenance information with IPB. All WPs described in [5.3.1](#) through [5.3.9](#) may have an introduction <intro>. Maintenance information with IPB data shall be developed and divided into the below listed types of WPs:

- a. Maintenance WPs.
- b. General maintenance procedures WP.

## MIL-STD-3001-4A(AS)

- c. Servicing WP.
- d. Ground operations WP.
- e. Support equipment maintenance WP.
- f. Local manufacturing and assembly WP.
- g. Power plant build-up WPs.
- h. Preinduction and mandatory inspection WP.
- i. External tubing, cabling, and clamping WPs.
- j. Separate IPB WPs.
- k. Wiring/cabling diagram WPs.
- l. Wire run lists WPs.

5.3.1 Maintenance work packages <maintwp>. Maintenance information shall be functionally divided into individual maintenance WPs <maintwp>. The technical content structure for these WPs shall be consistent from WP to WP. IPB illustration(s) shall be utilized to support the procedural maintenance steps. Other maintenance illustrations shall be included where a critical measurement, dimension, alignment, or inspection location must be identified. Supporting schematics and diagrams shall also be included. Supporting wiring/cabling diagrams or wire run lists shall also be included or provided in separate WPs (refer to [5.3.12](#) and [5.3.13](#)).

- a. Maintenance WPs shall include all authorized maintenance tasks. Tasks shall consist of complete start-to-finish maintenance procedures in a logical order of work sequence. Maintenance tasks are described in [5.3.1.1](#).
- b. Normally a repairable assembly requires complete coverage in a separate WP. However, when testing and troubleshooting and additional tools and test equipment or materials are not required, coverage may be included within the WP for the next higher assembly. When coverage for the repairable assembly is co-located with the next higher assembly, procedures for the repairable assembly should stand alone.
- c. Maintenance instructions shall reference or contain all procedures required for any unusual or critical steps such as specifying Quality Assurance (QA) checks, care and handling of ESD sensitive items and all hazardous material, including prevention of deterioration due to rough handling, exposure to adverse weather conditions, or other hazards.
- d. When peculiar to the equipment, applicable corrosion control procedures shall be included, or the WP shall reference applicable corrosion control publications.

## MIL-STD-3001-4A(AS)

e. National stock numbers (NSNs) shall not be used in WPs. Part numbers shall not be used in procedural steps, illustrations, or legends, except when essential for identification.

f. Instructions shall be prepared for any special maintenance required under extreme temperature, altitude, and humidity conditions within the limits established by the design specification for the equipment.

g. Mandatory compliance standard shop practices and techniques available in general maintenance series manuals shall not be included. When applicable, appropriate reference shall be made to these manuals in accordance with MIL-STD-3001-1, Appendix B.

5.3.1.1 Maintenance tasks. WPs shall be developed in a logical order for the maintenance tasks listed below, as applicable:

- a. Preparation for use and assembly <**prepuse**>.
- b. Handling <**handling**>.
- c. Stowage <**stow**>.
- d. Removal <**remove**>.
- e. Disassembly <**dissam**>.
- f. Cleaning and corrosion control <**clncorr**>.
- g. Inspection <**insp**>.
- h. Service <**service**>.
- i. Repair <**repair**>.
- j. Alignment <**align**>.
- k. Painting <**paint**>.
- l. Lubrication <**lube**>.
- m. Assembly <**assem**>.
- n. Test and inspection <**test-inspect**>.
- o. Installation <**install**>.
- p. Rigging <**rig**>.

## MIL-STD-3001-4A(AS)

- q. Adjustment <**adjust**>.
- r. Calibration <**calibrate**>.
- s. Preparation for storage or shipment <**pss**>.
- t. Environmental conditioning <**envircond**>.
- u. Safety information <**safe**>.
- v. Engine start and run-up <**engstart**>.
- w. Software loading <**softload**>.
- x. Fabrication <**fabricate**>.
- y. Packing <**packing**>.
- z. Unpacking <**unpacking**>.
- aa. Preservation <**preserve**>.
- ab. Tracking <**track**>.
- ac. Fueling <**fuel**>.
- ad. Defueling <**defuel**>.
- ae. Canning <**canning**>.
- af. Decanning <**decanning**>.

To enhance usability and clarity, all authorized maintenance tasks for a specific system, subsystem, equipment, or component may be contained in a single WP, or may be provided in a series of WPs. For example, all authorized maintenance tasks may be placed in a single WP, or removal and installation may be included in one WP; and disassembly, inspection, and assembly may be placed in a second WP. Division of WPs or selection of coverage will depend on various factors including but not limited to:

a. A WP may be determined by the operational modes, complexity of the maintenance action, or level(s) of maintenance covered.

b. Two or more WPs for an identical maintenance task may be required because the task is performed differently due to differences in configurations.

## MIL-STD-3001-4A(AS)

c. Development of more than one WP because the reduction in the size of the WP would make it more usable.

d. Development of one WP consisting of information that should be kept together because dividing the information into several WPs would degrade the usability.

e. Separate WPs due to different initial setup information for a set of maintenance tasks for a repairable component.

5.3.1.1.1 Maintenance task requirements. Additional mandatory or unique technical information requiring additional explanations for the maintenance tasks listed in [5.3.1.1](#) above is described in [5.3.1.1.2](#) through [5.3.1.1.16](#). The following general requirements apply to most of the maintenance tasks listed in [5.3.1.1](#) above:

a. Instructions shall be prepared for any peculiar installation of lockwire, cotter pins and use of sealing compounds, lubricants, or corrosion prevention compounds.

b. If servicing (i.e., pressurizing and charging with gas, lubrication, etc.) is required upon completion of a maintenance task, include this information as part of the task.

c. Procedures or practices that, if not correctly followed, could result in injury to personnel, damage or destruction to the equipment, or improper system operation shall be highlighted by warnings, cautions, and notes.

d. Appropriate warnings shall be included when hazardous chemicals and adverse health factors in the environment cannot be eliminated. Such warnings shall be identified by the related approved icon. Complete warnings shall be provided in the Hazardous Materials Warning Summary (HMWS) for each hazardous material used in the manual.

e. Torque requirements, values, and sequences shall be indicated. Torque values shall be given for all structural attaching hardware, fluid couplings (fuel, oil, hydraulic, pneumatic, etc.), and connections. Torque values shall include torque correction factors as in crowfoot extensions, thread lubricants, cadmium-plated screws, etc. Torque values identified in the tasks must reflect torque wrenches authorized. Upon completion of torque action, instructions shall be included for any additional action, such as use of an orientation mark.

f. Such terms as "reverse removal procedure" or "assemble in reverse order of disassembly" shall not be used in any maintenance task.

g. Maintenance procedures or steps that are essential to equipment performance or safety of personnel are considered to be Quality Assurance procedures and shall be highlighted by the addition of the abbreviation "(QA)" following the procedure/step. The last procedural step of a procedure shall reference the next required action to ensure that all required tasks, including final testing of the end item (verification of repair), are accomplished prior to completion of work.

## MIL-STD-3001-4A(AS)

5.3.1.1.2 Preparation for use and assembly.

a. As applicable, special procedures shall be prepared for unpacking, removing protective coatings, depreservation, and setting up equipment furnished in a partially assembled state. When the equipment is intended to be anchored or mounted in a fixed location and installed by a supporting facility, installation procedures are not required. If containers are to be used again, kept for future use, turned in to supply, or require special disposition, the necessary procedures shall be prepared.

b. Assembly, pre-installation, and installation procedures shall be prepared when needed. These instructions shall be supported by illustrations. When applicable, instructions for pre-oiling and preparation for initial run for engines shall be included. All information required to make the equipment fully operable shall be included. Instructions for cabling or plumbing that must be made up from bulk items, tests required during installation, power requirements, connections, and initial control settings needed for installation purposes shall be prepared. A reference to the operational checkout of the equipment shall be included for Quality Assurance.

5.3.1.1.3 Handling.

5.3.1.1.3.1 Handling <handling>. Instructions and precautions for ground handling of the aircraft/equipment under adverse conditions such as extreme cold, heat, humidity, dust, and high winds shall be prepared. Instructions for handling, loading and unloading, moving, mooring, including tie-down in high winds and sea state, shall be included. Specific wind velocities that could damage the aircraft shall be identified. For the purposes of the transportation of aircraft, procedures for the loading and unloading of aircraft into approved cargo aircraft or other applicable means of transportation shall be developed. Procedures to prepare the aircraft for loading, such as clearance checks, servicing, and protection required, including all warnings and cautions, shall be included. Once loaded, any aircraft tie-down procedures required shall also be included. The following ground handling procedures shall be provided, as applicable:

- a. Folding and unfolding <fold>.
- b. Cockpit entry and safety check <cock>.
- c. Towing <tow>.
- d. Moving <move>.
- e. Parking <park>.
- f. Mooring <moor>.
- g. Jacking <jack>.
- h. Hoisting <hoist>.



## MIL-STD-3001-4A(AS)

- i. Leveling <level>.
- j. Protective covers <procover>.
- k. Ground safety locks and pins <safelock>.
- l. Carrier deck handling <cardckhdl>.
- m. Preparation for catapulting <prepcat>.
- n. Loading <load>.
- o. Unloading <unload>.
- p. Arrested landing operation <arrlndop>.
- q. Fueling <fuelproc>.
- r. Defueling <defuelproc>.

5.3.1.1.3.2 **Handling (engines, aeronautical equipment, airborne weapons/equipment, and support equipment)**. Handling procedures for the end item, its sections, and components shall be provided, as applicable. Special handling procedures for transporting to and from ready-service stowage shall be included, emphasizing the use of handling equipment. For engines, coverage shall include handling instructions for engine removal from and installation in the shipping container and maintenance stand. The coverage shall also include instructions for transferring an engine to and from a transport trailer and use of a standard Navy rail system.

5.3.1.1.4 **Removal**.

- a. Removal procedures shall be written for assemblies/components individually rather than included as part of the removal instructions for the next higher assembly.
- b. For major components such as engines, procedures shall be prepared for sequential dismantling of the engine in sections, modules or major assemblies. Instructions shall indicate that care must be exercised to prevent the entrance of dirt and other foreign materials into the component, and, whenever practical, temporary covers shall be used to seal all openings in the dismantled component.
- c. For the transportation of aircraft, any components that require modification or removal to assist in the transportability shall be provided in the sequence of accomplishment.
- d. For the transportation of aircraft, procedures for the removal of any transport fixtures used in the transportation of the aircraft shall be included.

## MIL-STD-3001-4A(AS)

5.3.1.1.5 Disassembly. For major components such as engines, instructions shall include sequential procedures for disassembly of sections, modules, and subassemblies into component parts. Disassembly of component parts shall be covered only to the extent required for the authorized level of maintenance. Precautions to be observed and critical dimensions to be recorded shall be included. For the transportation of aircraft, any disassembly of the aircraft required to load the aircraft aboard the transport shall be provided.

5.3.1.1.6 Cleaning and corrosion control.

a. Peculiar instructions for cleaning the equipment and components shall be prepared. Only approved cleaning materials shall be used. Precautions to be observed and hazardous materials warnings shall be included, as applicable.

b. Methods and procedures for aircraft cleaning and general upkeep shall be prepared.

c. For major components such as engines, specific instructions for parts and subassemblies and cleaning methods such as special agents, ultrasonic, and compressed air not covered in general manuals or standard practices WPs shall be prepared. References to these documents shall be made, as necessary. Precautions to be observed during cleaning shall be specified. Instructions relating to preservation of metal parts and surface treatment after cleaning shall be included.

5.3.1.1.7 Inspection.

a. Instructions shall be prepared for inspection of the equipment and components during maintenance to determine when parts shall be replaced or repaired. Inspection methods, equipment required, and measurable accept or reject requirements and standards shall be prepared.

b. For engines and other dynamic components (such as transmissions and rotor heads) procedures shall include the required inspection methods, support equipment, and instructions for inspection of engine parts within the scope of the applicable level of maintenance. When applicable, tables or charts shall be used to present inspection criteria with specific applicable rework required for each out of tolerance condition (see [figure 2](#)). Inspection instructions shall encompass: failure, wear, fluid sampling, damage, corrosion, leakage, pressure checks, aging, burning, malfunctioning, deformation, and deterioration that can be expected to occur during service. Allowable service limits and adequate standards for determining when parts should be repaired or replaced shall be included. Illustrations shall be prepared whenever necessary to augment inspection tables and shall be clearly identified to correlate table(s) to illustration(s). Procedures shall be included for performing special inspections required when the component has operated beyond permissible limits, such as overspeed, over temperature, over torque, or sudden stoppage. Any requirements for special inspection by nondestructive methods shall be specified.

## MIL-STD-3001-4A(AS)

5.3.1.1.8 Repair.

a. Instructions shall be prepared for the repair of the equipment and its components to the extent authorized by the approved maintenance plan to restore an item to a completely serviceable or fully mission capable status. Minor repair actions that do not affect the integrity of the item shall also be included (e.g., fuse, lamp, or knob replacement). Minor repair actions of this type are not considered "complete repair actions" and as such may not justify assignment of a Source, Maintenance, and Recoverability [SM&R] Code (see NAVAIRINST 4423.11). Tables of acceptable tolerances and limits shall be included.

b. For major components such as engines, instructions shall be included for necessary repair to restore the engine section, module, or major subassembly to a completely satisfactory condition. Repair methods shall be specified for the correction of all deficiencies and conditions considered repairable within the scope of the level of maintenance to which the WP applies. Specific data shall be included to adequately describe repairs, including material specifications.

5.3.1.1.9 Assembly.

a. Procedures required for assembly of component parts into assemblies, subassemblies, and components of the equipment shall be included. Assembly instructions shall contain all pertinent assembly criteria, including clearances, back-lash criteria, dimensions, torque values, and similar data. Procedures shall be included to describe required alignment, adjustment, rigging, lubrication, painting, etc.

b. For major components such as engines, instructions shall cover assembly of component parts into subassemblies, sections, and modules. The use of required corrosion preventive methods, special lubricants, gasket pastes, and other such applications shall be specified. Location of piping and cabling shall be provided. Peculiar lockwiring methods and locking devices shall be emphasized. Testing requirements and methods shall be included for in-work progress testing of subassemblies during repair and assembly. Precautions to be observed and quality assurance requirements shall be included. As required, a calculation worksheet in the form of a table shall be provided identifying critical dimensions to be recorded (see [figure 3](#)). For Service Life Limited Items, the location of part number and serial number, by specific life limited part, must be indicated (see [figure 4](#)). When a procedure (step) states "if outside of limits, go to step x," the procedure shall also direct "go to step y" if within limits.

(1) Coverage shall include dimensional limits to be used for determining and maintaining proper relationship between mating parts in any particular assembly. These limits shall include all such data as clearances, gear lash, and end play.

(2) Illustrations (see [figure 5](#)) shall be prepared when necessary. When such illustrations are used, they shall include reference numbers and tabulation of the limits instead of the data appearing in the text. Reference numbers on the illustrations shall have leaders to the points of clearance, gear lash, or endplay and shall be listed in numerical order.

## MIL-STD-3001-4A(AS)

(3) Torque values shall be called out in the text where utilized and shall be noted as a Quality Assurance (QA) procedure/step.

(4) Coordination is required for engine assembly instructions related to the quick engine change (QEC) configuration. A reference to applicable engine buildup documentation shall be included to ensure correct engine assembly.

c. For the transportation of aircraft, any assembly of the aircraft required after unloading the aircraft from the transport shall be provided.

5.3.1.1.10 Test and inspection. Procedures shall be prepared for testing and inspection during or after assembly to ensure proper assembly of the item. Correct methods of testing, procedures for tolerance checks, and procedures for inspection of distance measurements (e.g., clearance, endplay, backlash, etc.) shall be included.

5.3.1.1.11 Installation.

a. Instructions shall be prepared for assemblies and repair parts. As applicable, procedures shall be provided for pre-installation setup, alignment, adjustment, rigging and servicing, including environmental conditioning and lubrication. A Quality Assurance (QA) reference to testing or pre-testing requirements shall be included after the last procedural step (e.g., end item alignment in a different WP).

b. For **engines (intermediate and depot only)**, instructions shall be prepared for the final assembly of sections, modules, and major assemblies to form a complete engine prior to performance test. Assembly procedures to check, align, and adjust each section, module, assembly, or subassembly shall be included. Precautions to be observed and quality assurance requirements shall be included. These instructions shall contain a statement that the assembled engine is to receive a checkout in accordance with applicable test instructions. When a procedure (step) states "if outside of limits, go to step x," the procedure shall also direct "go to step y" if within limits.

c. For the transportation of aircraft, installation procedures for any components that must be reinstalled after the aircraft has been transported shall be included.

d. For the transportation of aircraft, procedures for the installation of any transport fixtures used in the transportation of the aircraft shall be included.

5.3.1.1.12 Calibration. Calibration procedures shall not be included in any maintenance TM. However, if calibration is applicable, a reference shall be made to any separate calibration procedures or appropriate calibration TMs.

5.3.1.1.13 Preparation for storage or shipment. As applicable, the following instructions shall be prepared:

## MIL-STD-3001-4A(AS)

- a. Special instructions or precautions relative to storage procedures such as corrosion prevention, draining fluids, purging, moisture barriers or desiccant materials which are peculiar to the component/equipment.
- b. Reference to standard packaging procedures contained in other manuals and related documentation.
- c. For packaging and preservation requirements for NAVSUP WSS and NAVAIR repairable assemblies, a reference to NAVSUP P700-CNP, the CD-ROM containing the Navy Packaging Program in MIL-STD-2073-1.
- d. For handling an item that is ESD sensitive, a reference to NAVAIR 01-1A-23, Standard Maintenance Practices for Miniature/Microminiature (2M) Electronic Assembly Repair.
- e. Instructions for use of special shipping containers.
- f. Directions or reference to instructions for applying special identifying, shipping, and cautionary markings to shipping containers, including security classification, special temperature requirements, and shelf life.
- g. For major aircraft components such as engines, coverage shall include handling instructions for removal from and installation in the shipping container and maintenance stand. The coverage shall also include instructions for transferring components to and from a transport trailer and use of a standard Navy rail system.
- h. For **engines**, information shall be included for corrosion control in the form of effective prevention, recognition, and elimination procedures. Instructions shall also be included for short-term storage. The overall dimensions and weight of the shipping and storage container with the engine and its sections, modules or components packed in the container shall also be included.

5.3.1.1.14 Safety information <safe>. Safety information required to perform all maintenance tasks on aircraft systems, engines, aeronautical equipment, airborne weapons/equipment, and support equipment shall be provided, as applicable. For the **General Aircraft Information Manual only**, instructions and special safety precautions to be observed for the following unusual aircraft conditions shall be prepared: after an in-flight engagement of arresting cables, hot brakes, emergency canopy opening, de-arming of ejection seat, and any other unusual events applicable to the aircraft.

5.3.1.1.15 Engine start and run-up <engstart>. Instructions shall be prepared for engine start and run-up required to perform engine cockpit check. Reference shall be made to the appropriate NATOPS preflight checklist engine and cockpit check, if applicable.

## MIL-STD-3001-4A(AS)

5.3.1.1.16 Fabrication. Procedures shall be included, when applicable, for the fabrication of any special fixtures required for the transportation of an aircraft. These procedures shall include the identification, purpose and use of the fixtures and supporting illustrations providing precise dimensions of the fixtures.

5.3.2 General maintenance procedures work package <genmaintwp>. This WP shall contain any maintenance procedures that are lengthy and common to several WPs and referenced in the specific maintenance WP. It shall not include maintenance and repair procedures that are covered in general engineering series manuals. Maintenance tasks listed in [5.3.1.1](#) may be included, as applicable.

5.3.3 Servicing work package <servicwp> (General Aircraft Information, Plane Captain's, or Line Maintenance Manual only). This WP shall include all routine replenishment of expendable materials used during the operation of the aircraft, its weapon systems, or equipment. It shall not include periodic or scheduled servicing of systems or equipment covered by the Planned Maintenance Systems (PMS). Unscheduled servicing procedures shall also be provided as required. Lubrication and other maintenance procedures involving expendable materials during assembly or test of equipment shall not be considered servicing. The following instructions may be prepared in narrative, chart or tabular form:

a. Servicing instructions for replenishing fuel, oil, hydraulic fluid, oxygen, tire and landing gear strut pressures, and all other required aircraft servicing. Precautions to be observed while servicing shall be included.

b. Information shall include tank and reservoir capacities in U.S., Imperial, and metric units and shall identify "AN" (Army/Navy) or other Government specifications and grades as applicable. Fuel and oil capacity shall also be given by weight. Expansion volume, total capacity, and net capacity for each tank shall be included.

5.3.4 Ground operations work package <grndopwp> (General Aircraft Information, Plane Captain's, or Line Maintenance, Manual only). Instructions and precautions for ground operations of the aircraft/equipment shall be prepared. Procedures such as engine run-up and shutdown, aircraft and engine washing, and auxiliary power plant starting and shutdown shall be included when applicable. Certain ground handling procedures described in [5.3.1.1.3.1](#) may also be applicable and may be included in this WP.

5.3.5 Support equipment maintenance work package <semaintwp>. Maintenance procedures shall be developed for support equipment for aircraft weapon systems, aeronautical equipment, airborne weapons/equipment, and support equipment that is not covered in separate maintenance manuals. Instructions for required fabrication of peculiar tools, when such fabrication is approved by the requiring activity, shall be included. Maintenance data shall include the maintenance tasks listed in [5.3.1.1](#), as applicable. End items of support equipment coded as technically nonrepairable shall be included, but shall be supported by an illustration and parts list only.

## MIL-STD-3001-4A(AS)

5.3.6 Local manufacturing and assembly work package <locmfgwp>. Fabrication procedures for items source coded as "Make From" (MO, MF, MH, MG, MD) or "Assemble From" (AO, AF, AH, AG, AD) at the appropriate maintenance level shall be provided (see [figure 6](#)). The data shall include identification of the exact material required. When multiple items have common coverage requirements, the items may be covered in the same WP or series of WPs (e.g., cable assemblies). Simple procedures, adequately depicted in the IPB, shall not be covered. For **engines**, information required for the fabrication of items source coded "Make From" (MO, MF, MH, MG, MD) and "Assemble From" (AO, AF, AH, AG, AD) shall be included unless the manufacture of the item is obvious. Only those items listed in the applicable IPB shall be considered. The data shall include identification of the exact material required.

5.3.7 Power plant build-up work packages. A series of WPs shall be developed covering the build-up requirements for a basic engine to meet the configuration required for aircraft installation (see [figure 7](#)). Power plant build-up instructions shall cover applicability and interchangeability of quick engine change (QEC) units, preparation of engine build-up, and ground handling of engines. When required, the engine test procedures shall be referenced. IPB data shall be included in the WPs described in [5.3.7.1](#) through [5.3.7.5](#). The IPB data shall identify the Quick Engine Change Kit (QECK) items in accordance with [5.3.11](#).

5.3.7.1 General information work package <geninfomaintwp>. This WP shall contain general procedures and precautions, lockwiring and cotter pin installation, fitting installations, and standard torque values required to perform engine build-up.

5.3.7.2 Quick Engine Change Kit (QECK) description work package <qeckdescwp>. This WP shall include a listing of the components and equipment which comprise the QECK. A brief description of the components and equipment shall be included.

5.3.7.3 Quick Engine Change Assembly (QECA) work packages <qecawp>. WPs shall be developed for the removal of the basic engine from the Quick Engine Change Stand (QECS) and the installation of the basic engine in the QECS. Additional WPs shall be developed, in appropriate order of sequence, covering the installation instructions of all QECK components on the basic engine. These instructions shall include all securing and QA check procedures.

5.3.7.4 Non-Quick Engine Change Assembly (non-QECA) work packages <nonqecawp>. A series of WPs shall be developed, in appropriate order of sequence, for the teardown (removal) and build-up (installation) of all non-QECA components. These procedures are required to make the QECA a complete specific aircraft power plant. Instructions shall include all securing and QA check procedures.

5.3.7.5 Additional power plant build-up work packages <bldupwp>. WPs shall be prepared for additional procedures that may be required to complete the power plant build-up. These additional procedures may include preservation, packaging, depreservation, corrosion control, and structural repair, as applicable.

5.3.8 Pre-induction and mandatory inspection work package (engines only) <preindinspwp>. Pre-induction and mandatory inspection requirements covering any engine inducted at

## MIL-STD-3001-4A(AS)

intermediate or depot maintenance level shall be prepared as a separate WP. The WP shall detail inspection/investigation procedures. The depth of inspection/investigation shall depend upon remaining engine life, operational requirements and economic feasibility. Applicable WPs shall be referenced for details of removal, cleaning, inspection, repair, assembly, installation, and testing. The probable cause/corrective action and mandatory/recommended maintenance tasks to be taken for correction of engine defects shall be presented in two tables. The entries in the first table shall reflect the reported/confirmed defects, probable cause and corrective action (see [figure 8](#)). The second table shall include the mandatory/recommended maintenance tasks. Major inspection requirements for complete engine repair shall be identified (see [figure 9](#)).

5.3.9 External tubing, cabling, and clamping work packages (engines only). A series of WPs shall be developed for maintaining the external tubing, cabling, and clamping of the engine. Procedures <proc> for installation, positioning and identification of external tubing, cables, clamping, and attaching hardware shall be included. The following WPs shall be provided, as applicable:

- a. Numerical index WP.
- b. Bracket installation WP.
- c. External components WP.
- d. External tubing, cabling, and clamping installation WP.
- e. Critical clearances WP.

5.3.9.1 Numerical index work package <compindwp>. This WP shall contain a numerical index of external parts by part number, cross-referenced to their installation sequence number (see [figure 10](#)).

5.3.9.2 Bracket installation work package <brktwp>. This WP shall contain illustrations identifying the engine flanges and views of each flange that brackets are secured to. Flange identification and view direction, spacer size and location, bracket part numbers, angle location and direction, bolt head direction, and torque values shall be provided (see [figure 11](#)).

5.3.9.3 External components work package <extcompwp>. This WP shall indicate what external components, such as gearboxes, pumps, valves, and controls, must be installed prior to installation of tubing and cables. Reference shall be made to the applicable maintenance WPs.

5.3.9.4 External tubing, cabling, and clamping installation work package <extubwp>. This WP shall contain illustrations of the sides, top, and bottom views of the engine showing all tubing, cabling, clamping, and attaching hardware as it would appear when properly and completely installed (see [figure 12](#)). Numbers shall reflect installation sequence of each external part. The sequence number, part number, nomenclature, and zone figure for detailed installation data shall be prepared in tabular form as indicated on [figure 12](#). Critical clearance items shall be identified.



## MIL-STD-3001-4A(AS)

5.3.9.4.1 Zone references. An illustration depicting the engine zones shall be prepared as shown on [figure 12](#).

5.3.9.4.2 Zone detail views. A detailed view of each engine zone shall be prepared as shown on [figure 12](#). These zone detail figures shall contain complete information necessary to install all external parts and attaching hardware. A key (see [figure 12](#)) shall be prepared for each detail view.

5.3.9.5 Critical clearances work package <critclwp>. This WP shall illustrate the specific critical clearance areas and identify the minimum allowable measurement that is required to ensure sufficient clearance exists in those areas (see [figure 13](#)).

5.3.10 Sequence control chart (engines only). When specified by the requiring activity, a sequence control chart (SCC) shall be prepared. The SCC shall be a graphic presentation that will program the accomplishment of complete engine repair (CER) in a logical order. The presentation shall contain the major CER tasks and their required sequence, oriented to actual work time and manpower utilization (see [figure 14](#)).

5.3.10.1 Upper portion SCC. The upper portion of the SCC shall contain the following:

a. A table including identification of crew members, their rating (RTG), Military Occupational Specialty (MOS), and applicable WPs.

(1) Crew member no. - Number assigned to each specialist (no. 1 is normally the crew leader).

(2) RTG/MOS - The type of rating and MOS shall be determined in accordance with NAVPERS 18068, Manual of Navy Enlisted Manpower and Personnel Classifications and Occupational Standards and MCO 1200.17, Military Occupational Specialties Manual.

(3) Applicable WPs - The WP numbers of tasks assigned to each specialist. The WPs are in the engine intermediate maintenance manual.

b. Work Area Chart - An illustration of the engine with a breakdown of work areas numbered and identified in a legend.

c. Title block with notation that chart is to be used with applicable WPs (WPs) in engine intermediate maintenance manual and other applicable TMs (corresponding MRCs and the applicable manuals containing tubing, piping, and clamping maintenance).

d. A table with blocks for job numbers, times, and dates for four engines.

e. A publication number, date, and supersedure notice, when applicable.

5.3.10.2 Middle portion of SCC. Blocks in the middle portion of the SCC shall be arranged to identify specific tasks in the logical sequence of accomplishment. The block width shall be lined up with the time brackets in the lower portion. The task title and number shall be the same as the intermediate maintenance manual. The WP number shall be placed in the upper right-hand

## MIL-STD-3001-4A(AS)

corner of each block. The work area number(s) shall be located in the lower right-hand corner. WPs which contain major engine inspection requirements shall be identified by placing an asterisk before the WP number. Task assignments to specific crew members shall be shown at the left. Identification of the major engine inspection asterisk shall be shown.

5.3.10.3 Lower portion SCC. A graph coordinate for TIME shall be divided into equal vertical increments of one hour, and each hourly increment should be subdivided in six equal parts rated at ten minutes each. The graph shall display the total clock hours required to process the engine and individual tasks. In addition, the time allowed each crew member to accomplish specific tasks will permit a computation of man-hours per task. If task time is excessive and could cause the length of the SCC to exceed 52 inches, a reduction of areas used to reflect time should be made by grouping large individual time lapses of more than two hours into smaller increments. The tasks shall be listed by WP number in parentheses with the left parenthesis located at the time the task will begin and the right parenthesis at the time the task will be completed. Blocks for engine identification number and supervisor and crew member number shall be included at the left of the lower portion. The lower portion shall include provisions that will permit tracking and recording of four engines.

5.3.11 Illustrated parts breakdown data (IPB) <ipbwp>. IPB data shall be prepared as an integral part of the maintenance tasks (refer to [5.3.11.1](#)) unless specified otherwise by the requiring activity. When specified by the requiring activity, IPB data can be prepared as separate WPs (refer to [5.3.11.2](#)).

5.3.11.1 IPB data prepared as an integral part of the maintenance tasks <ipb>. IPB data shall be prepared as an integral part of the maintenance tasks and shall be included after the last maintenance task contained in a maintenance WP. The IPB shall track the maintenance task and include parts provisioned for the applicable maintenance level support of the item. Only those parts necessary to perform the maintenance procedures shall appear on the illustration and be listed in the group assembly parts list (GAPL). IPB data shall consist of an introduction and a figure(s). Each IPB figure consists of an illustration and a related GAPL.

a. IPB illustration. Each illustration shall adequately identify and locate repair parts. Multiple-view and multiple-sheet illustrations may be used. All illustrations shall precede the GAPL and, for greater clarity, be integrated with the maintenance procedures.

b. IPB GAPL. The GAPL (**standard table**) shall be prepared as a tabular listing of all authorized repair parts for use in the performance of maintenance. Basic top-down breakdown sequence shall not be used in the development of the GAPL data, unless it matches the maintenance task to be performed. The GAPL entries are described in [5.3.11.1.1](#) through [5.3.11.1.7](#).

c. Master usable on code list. When usable on codes are needed to reflect multiple application of items in an individual GAPL, a master usable on code list shall be developed and placed at the bottom of the last tabular page of the GAPL (e.g., Effectivity, used to indicate that the item is applicable only after, or before, incorporation of a technical directive and/or specific serial number application). Refer to [5.3.11.1.5](#) for usable on code requirements.

## MIL-STD-3001-4A(AS)

5.3.11.1.1 Index numbers. The index numbers that appear in the associated supporting illustrations shall appear as an entry under the heading "INDEX NO." in numerical sequence beginning with the number 1. Index numbers shall be assigned to all parts listed in the GAPL that have maintenance or supply significance, except as otherwise noted herein. Index numbers shall be first assigned to the GAPL and then applied to the IPB illustrations to maintain the proper sequence in the breakdown. If the same part number is listed more than once in the breakdown, it shall be assigned a different index number for each listing. No index number shall be assigned to an assembly when all detail parts are indexed, unless such assembly is also illustrated completely assembled on the illustration.

5.3.11.1.1.1 Index numbers for attaching parts.

a. Normally, index numbers shall be assigned to all attaching parts.

b. Fastening groups used at the same location (e.g., a relay attached by multiple nuts, bolts, and washers) need not be individually illustrated or identified by index number, unless maintenance significant. When group callouts are used, they shall contain only one particular size, combination, or group of parts.

(1) Each size, combination, or group of parts shall be listed separately.

(2) If an identical part, appearing at several locations, is attached with different attaching parts, the part shall be indexed separately.

(3) If more than one size or type of attaching part is used at different points on the part being attached, each size (with the pertinent attaching parts such as washer and nut) shall be given a separate index number so that the location of the different sizes and types may be readily identified in the illustration.

5.3.11.1.2 Part numbers. All end items, repair parts, and items of support equipment provisioned for the applicable maintenance level support of the article shall be listed by part number. Part numbers assigned to the parts listed shall appear as an entry under the heading "PART NUMBER."

a. Parts not to be listed. The following parts shall not be listed:

(1) Assembly detail parts that are permanently joined together. Parts that lose their identity by being welded or joined to other pieces as a permanent unit. This does not include riveted items provisioned for the applicable maintenance level of the manual.

(2) Items made from bulk stock. Items made from raw (bulk) stock such as lockwire, bonding braid, upholstery cloth, and friction tape.

(3) Structural items. Structural items which serve no purpose in description of parts relationship or specification of significant procured parts such as stringers, stiffeners, skin, doublers, and gussets. These items may be listed when required to maintain next higher assembly

## MIL-STD-3001-4A(AS)

identity or to identify items having maintenance significance. Does not apply to structural repair IPBs.

(4) Detail parts for consumable items. Details of items SM&R coded for throwaway.

(5) Substitute item. A substitute item is an item which possesses such functional and physical characteristics as to be capable of being exchanged for another under specific conditions or for particular applications and without alteration of the item itself or those adjoining it. Degradation of equipment performance will result when substitute items are used. Substitute items shall not be listed, unless authorized by the requiring activity.

b. Items without part numbers.

(1) Equipment that have not been assigned part numbers shall have the type or model number placed in the "PART NUMBER" entry. Either the type or model number shall be entered (e.g., the one that corresponds to a national stock number (NSN) that has an assigned SM&R code).

(2) If a vendor's part number is listed in the "PART NUMBER" entry, the type number, if applicable, shall be identified in the description.

(3) Parts which have neither a part number nor a type and model number assigned shall have a dash (-) placed in the "PART NUMBER" entry.

(4) Hardware procurable from normal commercial sources that does not have a part number assigned shall be identified by the abbreviation "COML" in the "PART NUMBER" entry. Identifying information such as dimensions, material, and type shall be given after the description to enable replacement procurement from commercial sources.

c. Standard hardware provisioned for lowest level of maintenance usage.

(1) Standard hardware (such as bolts, studs, packing, hose clips, fasteners, clamps, resistors, capacitors, diodes, transistors, gaskets) which are manufactured to conform to the requirements of NAS, JAN, USAF, NAVAIR, AN or MS drawings shall be listed.

(2) When an item of standard hardware has been provisioned at the lowest level of support regardless of multilevel application, only the quantity of hardware required at the applicable level(s) of maintenance covered shall be listed and illustrated.

d. Oversize and undersize parts. When oversize or undersize parts are required and furnished and they are neither interchangeable with, nor within allowable production tolerances of the standard size part, they shall be listed by the part number specified in the contract drawing specification.

e. Matched parts. When two or more parts that would normally be procured as separate items have been machined to fit as a matched set or lapped assembly, or have been matched

## MIL-STD-3001-4A(AS)

electronically to meet circuit requirements, the set of items shall be assigned a separate part number.

f. Contractor standard parts. Contractor standard parts shall only be listed when the NSN is assigned to the contractor standard part.

g. Government standard parts. Government standard part numbers shall be listed in the "PART NUMBER" entry. The part number shall be complete, including prefixes and suffixes to the basic number. If more than one Government standard part number is listed on the contractor drawing specification for a single application, the preferred part number shall be listed.

h. Government standard items containing nonstandard detailed parts. Items covered by Government standard drawings that contain repair parts that are not designated by Government detailed designed drawing numbers shall be listed in organizational level manuals by the Government standard part number when the NSN is assigned to the Government standard item.

i. Altered or source-controlled items. If any Government standard or commercial item is altered, selected, or source controlled because of special fit, tolerance, weight, or reliability of performance, the identity of the activity responsible for the alteration, selection, or source control shall appear in the "PART NUMBER" entry. Repainting, re-identifying, or other insignificant operations shall not be considered alterations, selections, or source controls.

j. Similar assemblies. If right and left, top and bottom, front and rear, or other similar assemblies contain a majority of identical parts, the IPB for the similar assemblies shall be combined and identified in the GAPL.

k. Symmetrically opposite parts. Symmetrically opposite parts shall be listed separately and identified in accordance with the contract drawing specification.

l. Subcontractor or vendor items. Subcontractor or vendor items are defined as items that are used by the manufacturer of the item covered by the IPB exactly as produced by a subcontractor or vendor. Repainting, re-identifying, or other insignificant operations shall not be considered alterations, selections, or source controls. When subcontractor or vendor items are assigned the NSN, the item part number shall be listed in the "PART NUMBER" entry.

m. Redesigned parts. If the design or material of a part is changed to the extent that interchangeability or physical or functional performance is affected, the new part number assigned in accordance with the contract drawing specification shall be listed. The original part shall be omitted if not authorized for continued use. If the original part has continued application, the application shall be indicated in the GAPL.

n. Selected electronic components. If a component board contains detail part(s) which can be replaced from a selection of components of different values, the illustration shall show one part. The GAPL shall list the basic part number without the specific value (e.g., "RCO7GF---J"). If the selection is to be made after test, a note shall appear after the description of the part (e.g., "/Value determined at test/").

## MIL-STD-3001-4A(AS)

o. Alternate parts. An alternate part is defined as a part that is used when a preferable part is not available. Alternate parts shall be listed below the preferred part when assigned an NSN. The specific relationship shall be identified in the GAPL "DESCRIPTION" and "USABLE ON CODE" entries.

p. Equivalent parts. An equivalent part is defined as a part that is used interchangeably with one or more parts, none of which are preferable over the other. Equivalent parts shall be listed below the preferred part when assigned an NSN. The specific interchangeability shall be identified in the GAPL "USABLE ON CODE" entry.

q. Quick Engine Change Assembly (QECA). Following the breakdown of the quick engine change assembly, the part number and description of the Quick Engine Change Kit (QECK), shall be listed. All QECK parts shall be illustrated, indexed, and identified in the GAPL "DESCRIPTION" entry with the acronym "QEC."

r. Parts kits. When repair parts for the end item or for repairable units within the end item are to be supplied in the form of kits, a part number shall be assigned to each kit in accordance with contract drawing specification requirements.

(1) The kit(s) part numbers shall be placed last in the list of parts of the unit to which it applies and at the same indentation as the unit to which it applies. The kit components listed shall carry the appropriate kit SM&R code.

(2) Contents of the kit shall be listed at one indent below the kit description and shall not be assigned index numbers. Part number, description, quantity per kit, and SM&R code shall be included for each item in the kit.

(3) Lists of supplemental kits shall follow the list of original kits in the same manner as prescribed herein.

(4) Separate illustrations for kits shall not be prepared.

s. Markings.

(1) Decals, metalcals, and vinyl film markings, such as those that provide instructions, which require replacement or must be requisitioned separately, are considered to be parts. The identifying drawing number for each marking shall appear in the "PART NUMBER" entry.

(2) Locations of markings shall be illustrated; however, legible copy of the marking on the illustration shall not be required.

(3) It is not required to list or illustrate a marking if:

(a) It is attached to a part or a nonrepairable assembly merely to identify it.

## MIL-STD-3001-4A(AS)

(b) The parts or nonrepairable assemblies are stocked, stored, and issued with the marking attached.

(c) The parts, not the marking, are replaced.

(d) Such markings shall not be requisitioned separately.

(4) When the illustration of a part or nonrepairable assembly seems to be incomplete with the marking omitted, it is proper to show, but not list, the marking.

t. Support equipment.

(1) Support equipment items requiring breakdown. Breakdown of support equipment listed in support of an end item shall be included when:

(a) The support equipment is peculiar to support the end item.

(b) Provisioning documentation dictates repair of the support equipment at the maintenance level coverage of the end item.

(c) A separate publication is not available or has not been authorized.

(2) Logistically nonrepairable support equipment. An illustration, part number, description of the item and units per assembly shall be included for these types of end items.

5.3.11.1.3 Description. The description as obtained from engineering drawings of the part listed shall be listed as an entry under the heading "DESCRIPTION." Additional specific technical content requirements for parts description are provided in [5.3.11.1.3e](#) through [5.3.11.1.3ac](#). The systems, subsystems, equipment, support equipment, components, and parts of the end item shall be indented to show next higher assembly relationship as follows:

a. Indentions to show item relationship. The end item nomenclature shall not be indented and shall be flush with the left margin in the description. Parts that comprise the end item shall be listed using indentions to show next higher assembly relationship. Runover lines of nomenclature shall be indented an additional indentation from the first line of nomenclature. Indention shall be indicated by leaders (a series of periods or dots) with one leader equal to one indentation. Indention to show end item to assembly, subassembly, and detailed part relationships shall be presented as shown in the following example:

END ITEM (FIGURE COVERAGE)

Runover line of nomenclature for End Item (Figure coverage)

. Detailed parts for End Item (Figure coverage)

. ASSEMBLY

(ATTACHING PARTS)

. Attaching parts for ASSEMBLY

## MIL-STD-3001-4A(AS)

- \*---
- . . Detailed parts for ASSEMBLY
  - . . SUBASSEMBLY  
(ATTACHING PARTS)
  - . . Attaching parts for SUBASSEMBLY
- \*---
- . . . Detailed parts for SUBASSEMBLY
  - . . . SUB-SUBASSEMBLY  
(ATTACHING PARTS)
  - . . . Attaching parts for SUB-SUBASSEMBLY
- \*---
- . . . . Detailed parts for SUB-SUBASSEMBLY

b. Parts kits.

(1) A statement indicating parts(s) availability shall be included after the description of the item or unit for which the kit is supplied.

(2) The kit(s) part numbers shall be placed last in the list of parts of the unit to which it applies and at the same indentation as the unit to which it applies.

(3) Part kits shall be at the same indentation as to the unit to which it applies.

(4) Kit contents shall be at one indent below the kit description.

(5) Lists of supplemental kits shall follow the list of original kits in the same manner as prescribed herein.

c. Listing attaching parts. Attaching parts shall be listed beneath the item to be attached. They shall be listed, preceding any detailed parts of the item, at the same indentation as the part they attach. The caption "(ATTACHING PARTS)" shall be placed one indentation to the right of the nomenclature of the part to be attached, on the line immediately above the list of attaching parts. The symbol "---\*---" shall follow the attaching parts, to separate the list from subsequent listings of parts. The separation symbol shall have the same indentation as "(ATTACHING PARTS)."

(1) If common attaching parts are used for more than one item and each item is assigned a separate index number, the attaching parts heading shall be expanded to so indicate. For example, if two clamps (one indexed -3, the other -4) are attached by one bolt, the correct attaching parts heading is "(ATTACHING PARTS FOR INDEX NUMBERS 3 AND 4)."

(2) If the attaching parts are the same for a number of items and these items are indexed and listed separately one after the other, the attaching parts shall be listed following the last item, and the attaching parts heading shall be expanded to indicate this. For example, if six connectors, each having a different part number with the same attaching parts, are indexed -1 through -6, the



## MIL-STD-3001-4A(AS)

correct attaching parts heading is "(ATTACHING PARTS FOR EACH OF INDEX NUMBERS 1 THRU 6)."

d. Nomenclature consistency. Nomenclature of identical systems, subsystems, equipment, support equipment, components, and parts of the end item shall be consistent throughout the GAPL and from WP to WP. The correct nomenclature shall be derived from one of the following sources (listed in the order of precedence):

- (1) "AN" nomenclature,
- (2) Nameplate nomenclature,
- (3) H-6 assigned nomenclature, or
- (4) Nomenclature on the drawing from which the item was manufactured.

e. Identifying noun and noun modifiers. The identifying noun shall be the first word of the description. Modifiers shall be arranged in the sequence as necessary to indicate specifics, such as function and location, and to maintain consistency of nomenclature. Modifiers shall be added to the description of parts as required to assure positive identification (e.g., washer, flat and washer, lock). These modifiers need not appear on the preparing activity drawing.

f. Hardness critical items. When the part is identified as a hardness critical item (HCI), the symbol [HCI] shall precede the nomenclature of the part in the "DESCRIPTION" entry. It is preferred that the symbol be placed within brackets, that is, [HCI]; however, other methods of highlighting the symbol to call attention to its importance are acceptable.

g. Electrostatic discharge (ESD) sensitive parts. When a part is identified as an item that is sensitive to electrostatic discharge (ESD), the symbol shall precede the first word in the "DESCRIPTION" entry. It is preferred that the symbol be placed within brackets, that is, [ESD]; however, other methods of highlighting the symbol to call attention to its importance are acceptable.

h. Abbreviation "ASSY" or "INSTL". If the item is an assembly or installation, the abbreviation "ASSY" or "INSTL," as applicable, shall follow the noun.

i. Drawing modifiers. The identifying noun or "ASSY" or "INSTL" shall be followed by the modifiers included in the drawing title description, and, when applicable, modifiers such as "upper," "lower," "inner," "outer," "front," and "rear" shall follow.

j. Commercial and Government Entity (CAGE) codes. Manufacturers' codes (or complete name if no code has been assigned) and references to other manuals or figures shall follow the description of the item. Manufacturer's codes shall not be listed for Government standard parts.

## MIL-STD-3001-4A(AS)

k. Dimensions. Where units of measurement are the same, they shall not be repeated with each dimension (e.g., "1/8 by 21/32 inch"). A zero shall precede the decimal point of decimal values less than one (e.g., "0.5").

l. Capitalization. The entire description may be in upper case letters. As a minimum, the item name shall be in upper case letters and the first letter of the first word immediately following the item name, and the first letter of proper nouns shall be upper case.

m. Abbreviations. Abbreviations shall be held to a minimum. Abbreviations shall be consistent throughout WPs.

n. Leaders. Leaders (a series of periods or dots) shall be used to join the description and the "UNITS PER ASSY" column. When the description requires more than one line, leaders shall only be used on the first line.

o. Tolerances for electrical/electronic parts. Percentages or actual values or allowable tolerances for such items as nonmilitary standard resistors and capacitors shall be given as part of the description, expressed as plus and minus values.

p. Undrilled or untrimmed parts. Parts that require drilling or trimming on installation shall be identified by a notation to that effect in the description.

q. Make from instructions. Most parts source coded MO, MF, MH, or MG require manufacturing instructions in the maintenance WP. These parts shall not have "Make From" information in the description column but will reference the maintenance WP. M-Series parts requiring only length, width or thickness and not requiring special manufacturing instructions shall include the raw (bulk) stock and final dimensions in the description. The list of raw (bulk) stock shall not be included for parts to be fabricated at depot level (SM&R coded MD).

r. Items using liquid oxygen (LOX). Items using LOX shall be identified by the acronym LOX if hazardous conditions could result from lack of this information. The acronym shall be placed at the far right on the same line containing the nomenclature of the part.

s. Quick engine change assembly (QECA).

(1) Repair parts, Government-furnished equipment and approved contractor-furnished accessories of an aircraft engine that also are included in the Quick Engine Change Assembly (QECA) shall be identified by the acronym "QEC" following the description of each repair part. The acronym shall appear at the far right on the same line containing the nomenclature of the part.

(2) Following the breakdown of the quick engine change assembly, the part number and description of the Quick Engine Change Kit (QECK) shall be listed. All QECK parts shall be illustrated and indexed.

(3) Basic aircraft engine parts shall not be identified with the acronym "QEC."

## MIL-STD-3001-4A(AS)

t. Magnetic control items (MAG). Parts requiring test for magnetic inclusion shall be identified by the acronym "MAG" to assist in the identification of such parts when malfunctions could result because of the lack of this information. The acronym shall appear at the far right on the same line containing the nomenclature of the part.

u. Oversize and undersize parts (dimensional differences). When oversize or undersize parts are required and furnished and they are neither interchangeable with, nor within allowable production tolerances of the standard size part, they shall be listed by the part number specified in the contract drawing specification. All dimensional differences shall be included in the description.

v. Similar assemblies.

(1) Peculiar parts notation. Parts peculiar to only one assembly shall be identified by a note in the description.

(2) Different quantity notation. Identical parts that are used in different quantities on the assemblies shall be listed separately and identified by a note in the description.

w. Matched parts (notation and parts listing). When two or more parts that would normally be procured as separate items have been machined to fit as a matched set or lapped assembly, or have been matched electronically to meet circuit requirements, the set of items shall be assigned a separate part number. A notation in the description column shall indicate that the item consists of a matched set or matched pair. The part numbers and nomenclature of the items that make up the set shall be listed in the description.

x. Subcontractor or vendor items (identification and/or drawing number). The descriptions of such items shall include the type, model, or applicable Government specification and the applicable manufacturer's code. If the manufacturer's code is not available, the name and address of the manufacturer shall be given. If such items are illustrated on preparing activity specification control or envelope drawings, the specification control or envelope drawing number shall also be listed in the description.

y. Redesigned parts. If the original part has continued application, "Alternate for" or "Use until exhausted," as applicable, shall follow the description of the part.

z. Selected items. If a component board contains a detail part which can be replaced from a selection of components of different values, the description shall contain the basic part number without the specific value (e.g., "RCO7GF---J"). If the selection is to be made after test, a note shall appear after the description of the part (e.g., "/Value determined at test/").

aa. References to other manuals. If coverage of the end item is contained in another manual, the applicable end item shall be listed and reference made to the manual by publication number only. References outside the TM shall not be made by WP numbers. The reference shall appear after the item description in diagonals or parentheses (e.g., "/Breakdown, NAVAIR 01-85ADA-4-6/" or "(Breakdown NAVAIR 01-85ADA-4-6)").

## MIL-STD-3001-4A(AS)

ab. References to other figures in the same manual or volumes of the manual. If coverage is contained in another figure or WP, the applicable end item shall be listed and reference made to the figure number. If an item has additional maintenance coverage in another WP, the reference to that WP shall appear after the item description in diagonals or parentheses (e.g., "/Breakdown, F0011-00/" or "(Breakdown, F0026 00)").

ac. Next higher assembly references. Necessary reference shall be made to other figures for next higher assemblies. The reference shall appear after the item description in diagonals or parentheses (e.g., "/NHA, F0079-00/" or "(NHA, A1-F18AA-XXX-XXX F0081-00)").

5.3.11.1.4 Units per assembly. The number of units required per assembly, per subassembly, and per sub-subassembly, as applicable, shall be listed as an entry under a heading "UNITS PER ASSY."

- a. The entries under "UNITS PER ASSY" shall be aligned with the first line of multiple-line descriptions.
- b. If more than one assembly is required, the total of such assemblies shall be indicated.
- c. For detailed or subassembly parts of a major assembly, the quantity required for one major assembly shall be indicated.
- d. For oversize or undersize parts, the letters "AR" shall be placed in this column to indicate "as required."
- e. For items that are listed for reference, the letters "REF" (item listed elsewhere in the IPB) shall be placed in the column.
- f. Quantities of attaching parts shall be listed per unit (piece) only. For example, if two fittings are required for each preceding assembly and one bolt is required to attach both fittings, the correct listing is as follows:

| DESCRIPTION                              | UNITS<br>PER<br>ASSY |
|--|----------------------|
| FITTING ASSY, HINGE<br>(ATTACHING PARTS) | 2                    |
| BOLT                                     | 1                    |
| ---*---                                  |                      |

5.3.11.1.5 Usable on code. Usable on codes for assemblies and parts to indicate their specific usability with the end item to which the IPB figure applies shall be listed as an entry under a heading "USABLE ON CODE." Capital letters shall be used to identify the application of the items. If single letters of the alphabet are not sufficient to complete coding, double letters may be

## MIL-STD-3001-4A(AS)

used (i.e., AA, AB, etc.). The letters O and I shall not be used singularly or in pairs. No usable on code shall be used for assemblies and parts that are applicable to all end items.

a. Simple application. When different end item part numbers are identified, each end item shall be assigned a code in sequence and that code shall be listed for each peculiar item in the parts list. More than one code may be assigned to the same item (e.g., A, B or A, C).

b. Redesigned parts. If the original part has continued application, the applicable model, block numbers, and serial numbers of the items on which the part is usable shall be indicated by usable on codes.

c. Alternate parts. An alternate part is defined as a part that is used when a preferable part is not available. When an item is completely interchangeable but one part is preferable for use, the number of the preferred part shall be listed without a notation in the "USABLE ON CODE" entry and all alternate part numbers shall be listed with an asterisk (\*) in the "USABLE ON CODE" entry. When an item is completely interchangeable on certain end items, but one part number is preferable for use, the "USABLE ON CODE" entry shall carry the end item identification, with or without an asterisk (\*), as applicable.

d. Equivalent parts. An equivalent part is defined as a part that is used interchangeably with one or more parts, none of which are preferable over the other. All equivalent part numbers shall be listed with an asterisk (\*) in the "USABLE ON CODE" entry. When a part is interchangeable only on certain end items the "USABLE ON CODE" entry shall carry the end item identification in addition to the required asterisk (\*).

5.3.11.1.6 SM&R code. The source, maintenance, and recoverability (SM&R) code for every part for which one has been approved by the Government shall be listed as an entry under a heading "SM&R CODE."

5.3.11.1.7 Work unit code (WUC). When the equipment, assembly, subassembly, or component part has been assigned a WUC, the WUC shall be listed under this entry.

5.3.11.1.8 Detailed IPB technical content requirements. General guidelines for IPB GAPL and illustration development are provided in [5.3.11](#) through [5.3.11.1.7](#). Additional detailed technical content requirements for GAPL and illustration development are contained in [5.3.11.1.8.1](#) through [5.3.11.1.8.9](#).

5.3.11.1.8.1 Nuclear hardness critical items [HCI]. When survivability considerations are specified and Hardness Critical Items (HCI) are identified on drawings and parts lists, the items must be marked and identified in the "DESCRIPTION" entry of the Group Assembly Parts Lists (GAPL). All changes to or proposed substitutions of HCIs must be evaluated for hardness impacts by the engineering activity responsible for survivability. The Introduction (refer to MIL-STD-3001-1, Appendix B) shall include an explanation of the [HCI] symbol's usage and method of highlighting and other pertinent information as necessary to emphasize uniqueness of HCIs.

## MIL-STD-3001-4A(AS)

5.3.11.1.8.2 Electrostatic discharge (ESD) sensitive parts. If electronic equipment to be handled, inspected, repaired or assembled is ESD sensitive, the items must be marked and identified in the "DESCRIPTION" entry of the GAPL. The Introduction (refer to MIL-STD-3001-1, Appendix B) shall include an explanation of the [ESD] symbol's usage and method of highlighting and other pertinent information as necessary to emphasize uniqueness of ESD sensitive components.

5.3.11.1.8.3 Index numbers on illustrations. Index numbers, with leader lines to the parts to which they pertain, shall be used on all IPB illustrations. Index numbers are assigned in accordance with [5.3.11.1.1](#). The index numbers on each illustration shall agree with those in the GAPL. Additional nomenclature may be added to these illustrations in order to properly identify parts not listed and indexed in the GAPL in order to properly indicate the relationship of parts to assemblies and to better present the maintenance procedures.

5.3.11.1.8.4 Attaching parts on illustrations. Each part in a set of attaching parts (such as bolt, washer, nut) shall be assigned an index number. Sets of attaching parts shall be exploded when the assembly is hidden and sufficiently complex to merit explosion. The total quantity of each item listed in the GAPL shall be identified with index numbers in the illustration. To avoid cluttering an illustration with unnecessary index numbers, large quantity items need not be indexed more than once on the illustration or on each sheet of a multisheet illustration on which the part is shown. However, the location of the items must be obvious in the illustration. For example, multiple size rivets that are shown in various locations on the illustration need only be indexed once for each part number listed in the GAPL.

5.3.11.1.8.5 Indexing assemblies. Each assembly and subassembly of the end item shall be shown assembled and assigned an index number. Assemblies and subassemblies coded for assembly, manufacture, or repair at the applicable maintenance level shall also be shown exploded in a detail view on the main illustration or in a separate illustration, and index numbers shall be assigned to all detailed parts.

5.3.11.1.8.6 Items not having a logical maintenance sequence. For items not having a logical maintenance sequence (e.g., circuit card assembly), begin assigning index numbers at the top left-hand corner and continue clockwise.

5.3.11.1.8.7 Component boards. When a component board or bracket assembly that holds electrical components is presented orthographically, the reference designation may be placed within the view of the part, if space permits. Leader lines may be used to identify reference designations that cannot be placed within the view of the part. When the number of leader lines to indexed parts causes the illustration to become cluttered, the figure may contain a legend adjacent to the artwork or on a separate sheet. The listing shall contain an alphanumerical listing of the reference designations and their associated index numbers. Index numbers for items with reference designations shall be identified using the legend and not on the artwork. Index numbers will be used only to identify items that do not have reference designations.

## MIL-STD-3001-4A(AS)

5.3.11.1.8.8 Polarity identification. When applicable, the polarity of electronic components shall be identified on the component of all maintenance illustrations.

5.3.11.1.8.9 Reference designations. Illustrations that depict electrical components should include reference designation after the index number. If an orthographic view is prepared, the reference designation may be placed within the view of the part, if space permits.

5.3.11.2 Separate IPB work packages <ipbwp> (for paged-based manuals only). When specified by the requiring activity, a separate IPB WP or a series of IPB WPs shall be prepared. When more than one IPB WP is required, the IPB WPs may be presented immediately following each applicable maintenance WP, or all IPB WPs shall follow the last maintenance WP in the manual. An introduction for the IPB shall be included in the introduction to the manual.

5.3.11.2.1 IPB work package content. Each IPB WP shall consist of an illustration or a series of illustrations and the related Group Assembly Parts List (GAPL). When usable on codes are used in the GAPL, a list of the usable on codes and an explanation of each code shall be provided at the end of the GAPL. The technical content requirements for the GAPL are identical to those provided in [5.3.11.1b](#) through [5.3.11.1.8.9](#).

5.3.12 Wiring/cabling diagram work packages <wirediawp>. Wiring diagrams or cabling diagrams required to support the maintenance procedures may be included in separate WPs, especially when a large number of wiring or cabling diagrams are required. Wiring/cabling diagrams shall be developed that adequately contain the maintenance data required by the technician to complete the maintenance task for aircraft system, aircraft wiring or equipment maintenance. A series of wiring diagram WPs shall be developed, as required, to illustrate the wiring of all aircraft systems, subsystems, and equipment. When aircraft weapons systems provide separate wiring diagram manuals, a reference or link shall be made in lieu of creating a separate WP. Wiring diagram WPs shall have an introduction <intro>.

5.3.13 Wire run lists work packages <wirelistwp>. Wire run lists required to support the maintenance procedures may be included in separate WPs, especially when these wire run lists are large in size. Wire run list WPs shall contain tables listing all wires for the aircraft systems, subsystems, and equipment. Wire list WPs shall have an introduction <intro>. Wires shall be listed in alphanumeric sequence by system wire number or reference designation. At a minimum, the following data shall be provided for each wire listed.

- a. The wire from-to destination by item reference designation/pin number.
- b. Wire size.
- c. Wire number identification and part number, if applicable.
- d. Any pertinent remarks, if applicable.

## 6. NOTES

The notes in Section 6 of MIL-STD-3001-1 apply to this Part.

## MIL-STD-3001-4A(AS)

|   |                                  |                          |
|---|----------------------------------|--------------------------|
| <b>AN-500AC-510-000</b>   |                                  | <b>010 00</b>            |
| 15 January 1994   |                                  |                          |
| <b>INTERMEDIATE</b>   |                                  |                          |
| <b>MAINTENANCE WITH ILLUSTRATED PARTS BREAKDOWN</b>   |                                  |                          |
| <b>ELECTRONIC COMPONENTS ASSEMBLY, SYSTEM TIMING A1</b>   |                                  |                          |
| <b>PART NUMBER 3382W57G702</b>  |                                  |                          |
| <b>Reference Material</b>   |                                  |                          |
| Avionic Cleaning and Corrosion Prevention/Control .....   |                                  | NAVAIR 16-1-540          |
| Master Test Program Set Index (MTPSI) .....   |                                  | MTPSI F/A-18/484( )      |
| Standard Maintenance Practices Electronic Assembly Repair .....   |                                  | NAVAIR 01-1A-23          |
| <b>Support Equipment Required</b>   |                                  |                          |
| <b>Nomenclature</b>   | <b>Part Number</b>               | <b>CAGE Code</b>         |
| Torque Wrench   | 0-96 inch ounces                 |                          |
| <b>Materials Required</b>   |                                  |                          |
| <b>Nomenclature</b>   | <b>Specification/Part Number</b> | <b>HMWS Index Number</b> |
| Loctite C   | MIL S 22473 GRC                  |                          |
| <b>1-1. DISASSEMBLY.</b>  |                                  |                          |
| <b><u>CAUTION</u></b>   |                                  |                          |
| Electronic Components Assembly, System Timing A1 contains ESD. Failure to handle properly will result in damage to the equipment. Refer to NAVAIR 01-1A-23. |                                  |                          |
| 1-2. For disassembling Electronic Components Assembly, refer to 1 and NAVAIR 01-1A-23.  |                                  |                          |
| <b>2-1. CLEANING.</b>   |                                  |                          |
| <b><u>CAUTION</u></b>   |                                  |                          |
| Electronic Components Assembly, System Timing A1 contains ESD. Failure to handle properly will result in damage to the equipment. Refer to NAVAIR 01-1A-23. |                                  |                          |
| 2-2. Perform cleaning and corrosion prevention/control in accordance with NAVAIR 16-1-540.  |                                  |                          |
| <b>3-1. INSPECTION.</b>   |                                  |                          |
| <b><u>CAUTION</u></b>   |                                  |                          |
| Electronic Components Assembly, System Timing A1 contains ESD. Failure to handle properly will result in damage to the equipment. Refer to NAVAIR 01-1A-23. |                                  |                          |
| 1. Visually inspect for burned, brittle or cracked wiring insulation.   |                                  |                          |
| 2. Check for loose connectors, dirty or corroded contacts, bent or broken pins, or other physical damage.   |                                  |                          |
| <b>1</b>  |                                  |                          |

FIGURE 1. Example of task-oriented maintenance with IPB work package.



## MIL-STD-3001-4A(AS)

**AN-500AC-510-000****010 00**

4. Inspect all solder joints for corrosion.
5. Check all markings for legibility.
6. Check all electrical contacts for dirt and corrosion.

**4-1. REPAIR.****CAUTION**

Electronic Components Assembly, System Timing A1 contains ESD. Failure to handle properly will result in damage to the equipment. Refer to NAVAIR 01-1A-23.

1. For printed wiring board repair refer to NAVAIR 01-1A-23.

**5-1. ASSEMBLY.****CAUTION**

Electronic Components Assembly, System Timing A1 contains ESD. Failure to handle properly will result in damage to the equipment. Refer to NAVAIR 01-1A-23.

1. For assembling the Electronic Components Assembly, refer to 1 and NAVAIR 01-1A-23.



**Loctite Retaining Compounds 3**

2. Apply Loctite C to the threads of connector screws (8).
3. Torque connector screws (8) 80 inch ounces.

**6-1. ILLUSTRATED PARTS BREAKDOWN.**

6-2. The illustrated parts breakdown, 1, contains information necessary for identifying and ordering parts. An introduction to the IPB, explaining its use and application is contained in WP 002 00.

FIGURE 1. Example of task-oriented maintenance with IPB work package - Continued.

MIL-STD-3001-4A(AS)

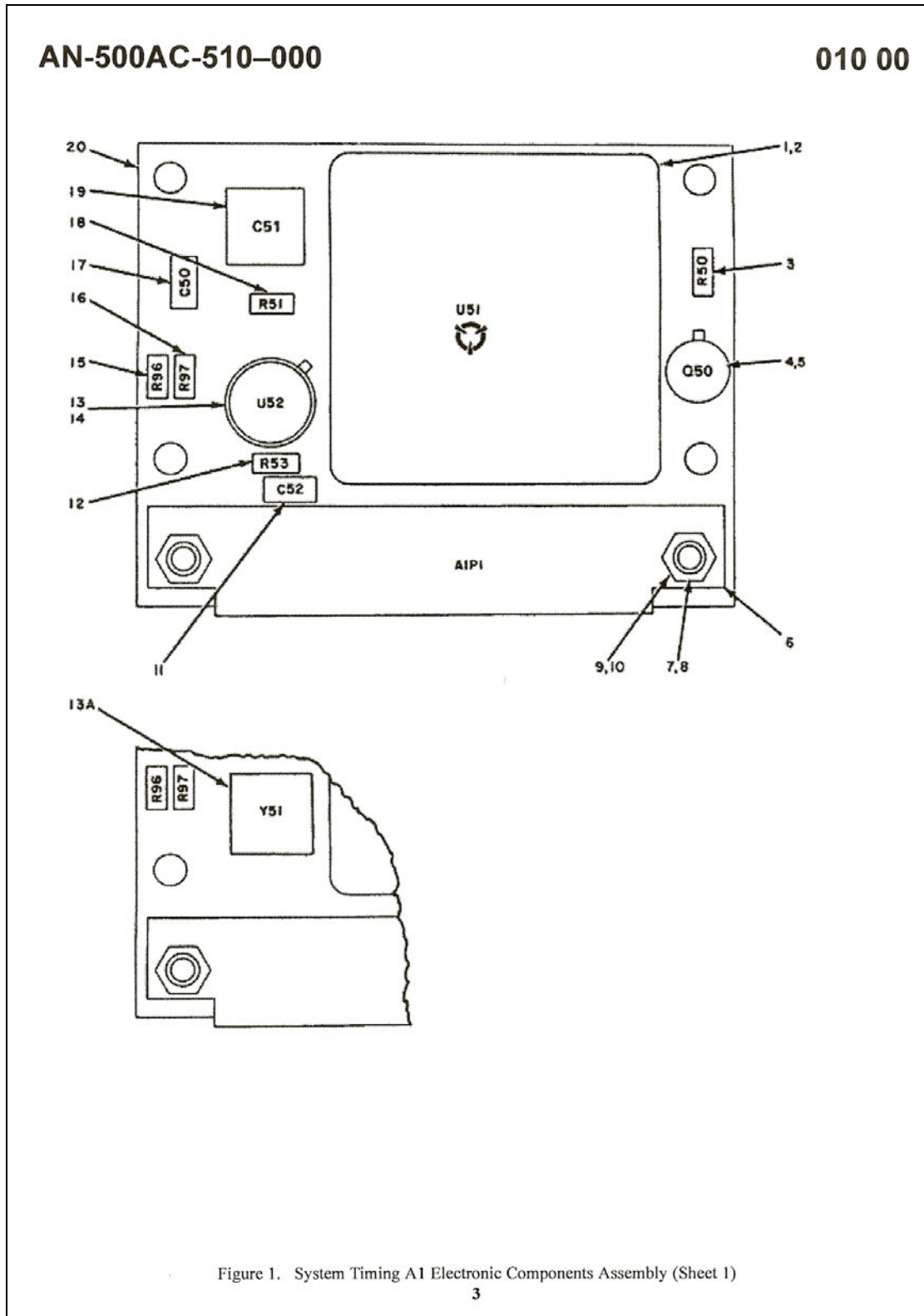

FIGURE 1. Example of task-oriented maintenance with IPB work package - Continued.

## MIL-STD-3001-4A(AS)

| AN-500AC-510-000  |                       |  | 010 00         |                |           |
|-------------------|-----------------------|--|----------------|----------------|-----------|
| Index No.         | Part Number           | Description<br>1 2 3 4 5 6 7   | Units per Assy | Usable On Code | SM&R Code |
|                   | 3382W57G702           | ELECTRONIC COMPONENTS ASSEMBLY, SYSTEM<br>TIMING A1 /NHA, WP00400/ ..... | REF            |                | PAGGD     |
| 1                 | 6900W60P002           | • INTEGRATED CIRCUIT.....  | 1              |                | PAGZZ     |
| 2                 | 4594W52P002           | • INSULATION.....  | 1              |                | PAGZZ     |
| 3                 | RCR05G103JS           | • RESISTOR.....  | 1              |                | PAGZZ     |
| 4                 | JANTXV2N2222A         | • TRANSISTOR.....  | 1              |                | PAGZZ     |
| 5                 | RM968                 | • INSULATION /08530/ /SCD 4594W11P002/.....                              | 1              |                | PAGZZ     |
| 6                 | M55302/57A26Y1        | • CONNECTOR.....   | 1              |                | PAGZZ     |
| (ATTACHING PARTS) |                       |  |                |                |           |
| 7                 | N248P9E-1             | • NUT.....   | 2              |                | PAGZZ     |
| 8                 | MS51957-15            | • SCREW.....   | 2              |                | PAGZZ     |
| 9                 | MS35338-135           | • WASHER, LOCK.....  | 2              |                | PAGZZ     |
| 10                | N400P5-1              | • WASHER.....  | 2              |                | PAGZZ     |
| ---*---           |                       |  |                |                |           |
| 11                | M39014/01-1357        | • CAPACITOR .....  | 1              | B              | PAGZZ     |
|                   | M39014/01-1237        | • CAPACITOR (alternate).....   | 1              | *B             | PAGZZ     |
| 12                | RCR05G392J2           | • RESISTOR.....  | 1              | B              | PAGZZ     |
| 13A               | 2865W10P034           | • CRYSTAL.....   | 1              | A              | PAGZZ     |
| 13                | M55310/09-B01A-800KHZ | • OSCILLATOR.....  | 1              | B              | PAGZZ     |
| 14                | 10230                 | • INSULATION /07047/ /SCD 4594W93P003/ .....                             | 1              |                | PAGZZ     |
| 15                | RLR05C1402GR          | • RESISTOR.....  | 1              |                | PAGZZ     |
| 16                | RLR05C1103GR          | • RESISTOR.....  | 1              |                | PAGZZ     |
| 17                | M39014/01-1593        | • CAPACITOR .....  | 1              |                | PAGZZ     |
| 18                | RCR05G102JS           | • RESISTOR.....  | 1              |                | PAGZZ     |
| 19                | M39014/02-1419        | • CAPACITOR .....  | 1              |                | PAGZZ     |
| 20                | 5852W57P002           | • PRINTED WIRING BOARD.....  | 1              |                | XAGZZ     |

| USABLE-ON-CODE LIST |              |                                    |
|---------------------|--------------|------------------------------------|
| Usable On Code      | Model Number | Remarks                            |
| A                   |              | Before Indicator Serial Number 350 |
| B                   |              | Indicator Serial Number 350 and Up |

Figure 1. System Timing A1 Electronic Components Assembly (Sheet 2)

4

FIGURE 1. Example of task-oriented maintenance with IPB work package - Continued.

## MIL-STD-3001-4A(AS)

| INSPECT                                       | MAX. SERVICEABLE LIMITS   | MAX. REPAIRABLE LIMITS | CORRECTIVE ACTION |
|---|---------------------------|------------------------|-------------------|
| 1. 1st stage bushings for:                    |                           |                        |                   |
| a. Wear                                       |                           |                        |                   |
| (1) Wall thickness                            | 0.0555 in. min. thickness | Not repairable         | Replace bushing   |
| (2) Outside diameter                          | 0.622 in. min. dia.       | Not repairable         | Replace bushing   |
| 2. 2nd stage bushing for:                     |                           |                        |                   |
| a. Wear                                       |                           |                        |                   |
| (1) Wall thickness                            | 0.056 in. min. thickness  | Not repairable         | Replace bushing   |
| 3. 3rd stage bushing for:                     |                           |                        |                   |
| a. Wear                                       |                           |                        |                   |
| (1) Flange thickness                          | 0.050 in. min. thickness  | Not repairable         | Replace bushing   |
| (2) Wall thickness                            | 0.055 in. min. thickness  | Not repairable         | Replace bushing   |
| (3) Outer diameter                            | 0.499 in. min.            | Not repairable         | Replace bushing   |
| (4) Bore diameter                             | Up to 0.389 in. dia.      | Not repairable         | Replace bushing   |
| b. Damage (other than detailed in this table) | Not serviceable           | Not repairable         | Replace bushing   |

FIGURE 2. Example of inspection procedures.

## MIL-STD-3001-4A(AS)

| ENGINE S/N:                          |  |                       |               |
|--------------------------------------|--|-----------------------|---------------|
| ENGINE MODEL NO: <b>F402-RR-404A</b> |  |                       |               |
| BUILD DATE:                          |  |                       |               |
| BUILD ACTIVITY:                      |  |                       |               |
| <b>LP COMPRESSOR SECTION</b>         |  |                       |               |
| <b>WORK PACKAGE</b>                  | <b>DIMENSION/CLEARANCE</b>             | <b>LIMIT (INCHES)</b> | <b>RECORD</b> |
| 129 00                               | BLADE TIP CLEARANCE<br>LPC3 / LPC CASE | 0.060 MIN.            |               |
| 129 00                               | LPC2 VANES                             |                       |               |
|                                      | DIMENSION <b>A</b>                     | 20.290 MIN.           |               |
|                                      | DIMENSION <b>B</b>                     | 20.420 MAX.           |               |
| 129 00                               | BLADE TIP CLEARANCE<br>LPC2 / LPC CASE | 0.080 MIN.            |               |
| 129 00                               | LPC1 VANES                             |                       |               |
|                                      | DIMENSION <b>A</b>                     | 16.908 MIN.           |               |
|                                      | DIMENSION <b>B</b>                     | 17.052 MAX.           |               |
| 129 00                               | BLADE TIP CLEARANCE<br>LPC1 / LPC CASE | 0.135 MIN.            |               |

FIGURE 3. Example of a dimensional calculation worksheet.

MIL-STD-3001-4A(AS)

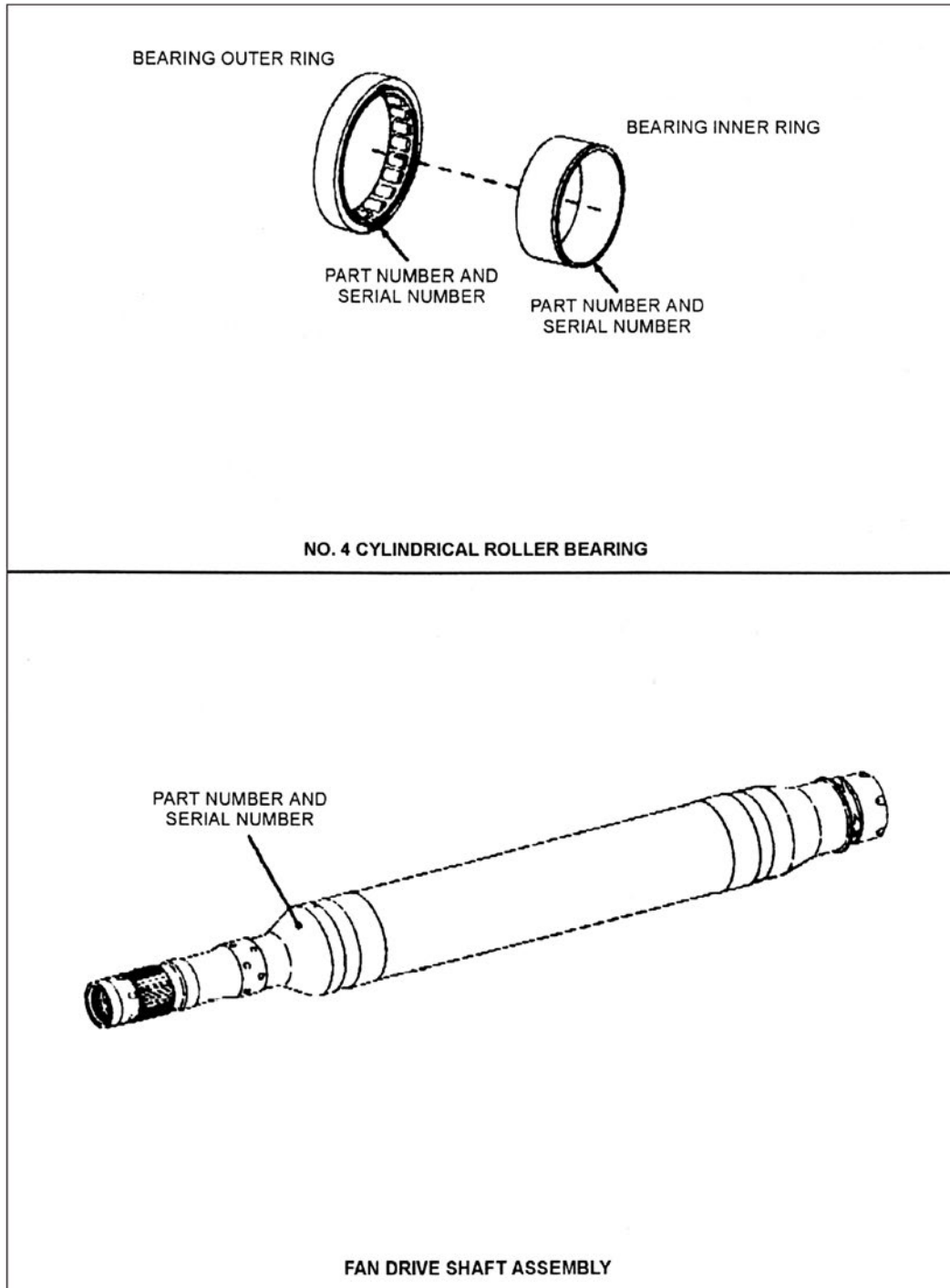

FIGURE 4. Example of location of part number and serial number for service life limited items.

## MIL-STD-3001-4A(AS)

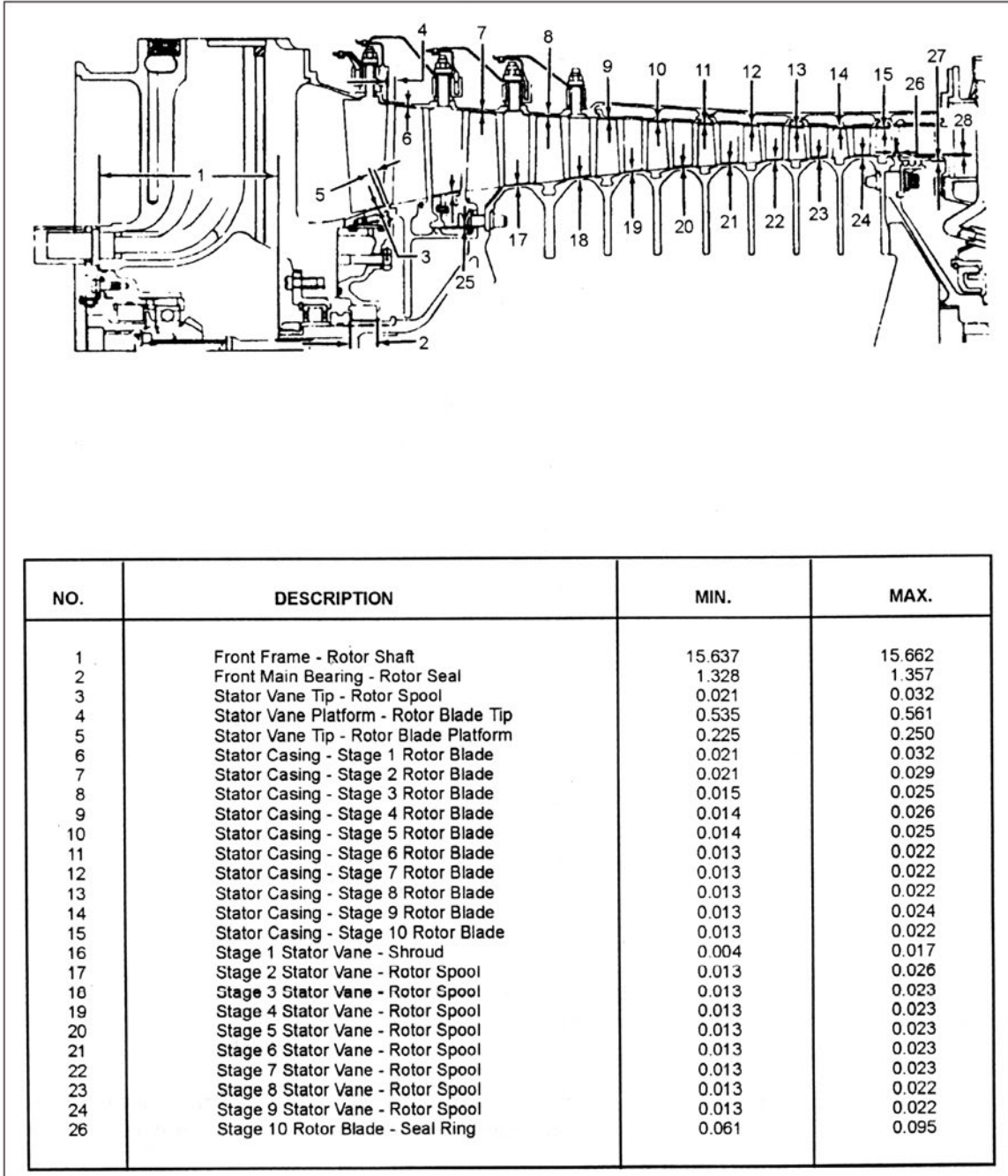

FIGURE 5. Example of dimensional data.

## MIL-STD-3001-4A(AS)

|   |               |
|---|---------------|
| <b>NAVAIR 02B-105AHE-6-1</b>  | <b>014 00</b> |
| 1 August 1996   |               |
| <hr/> <b>INTERMEDIATE MAINTENANCE</b><br><b>LOCAL MANUFACTURING AND ASSEMBLY</b><br><b>T58-GE-16 ENGINES</b><br><b>216001 AND SUBSEQUENT</b> <hr/>  |               |
| <b>Reference Material</b>   |               |
| Alphanumerical Listing of Support Equipment..... WP 013 00  |               |
| Standard Maintenance Practices Manual..... NAVAIR 02-1-20   |               |
| <b>1-1. INTRODUCTION.</b>   |               |
| 1-2. This Work Package (WP) contains instructions for the local manufacture of Support Equipment used at the intermediate levels of maintenance of the T58-GE-16 engines. A complete list of Support Equipment is available in WP 013 00. |               |
| <b>2-1. CARE AND MAINTENANCE.</b>   |               |
| 2-2. For instructions on the calibration, care and maintenance of Support Equipment, refer to NAVAIR 02-1-20.   |               |
| <b>3-1. LOCALLY MANUFACTURED TOOLS.</b>   |               |
| 3-2. The following tools shall be fabricated locally:   |               |
| <ol style="list-style-type: none"> <li>1. No. 2 bearing rear stationary seal support guiding pin (figure 1).</li> <li>2. Static fuel filter bowl removal and installation tool (figure 2).</li> </ol>                                     |               |
| 1   |               |

FIGURE 6. Example of a local manufacturing and assembly work package.



MIL-STD-3001-4A(AS)

NAVAIR 02B-105AHE-6-1

014 00

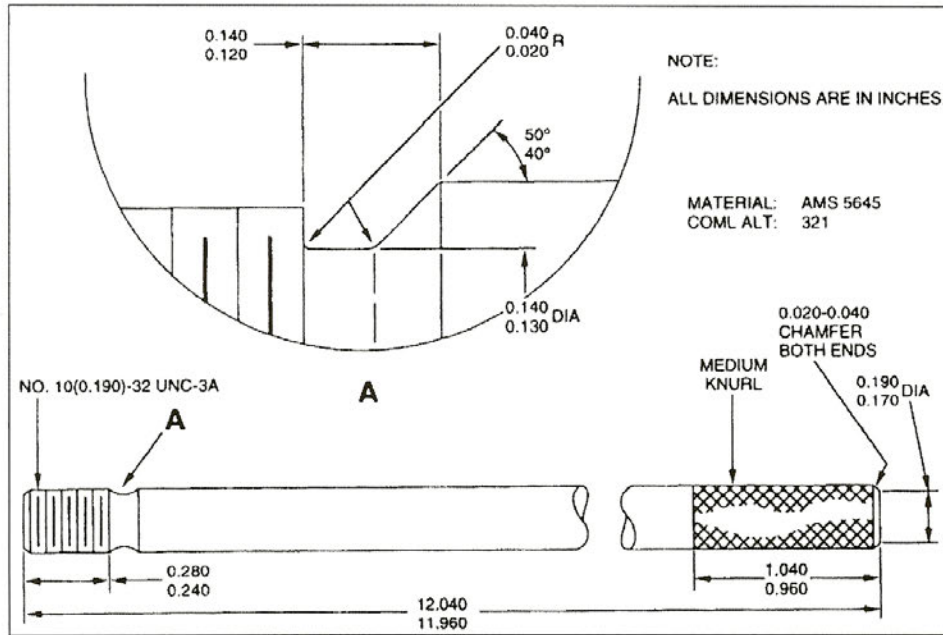

Figure 1. Seal Support Guiding Pin.

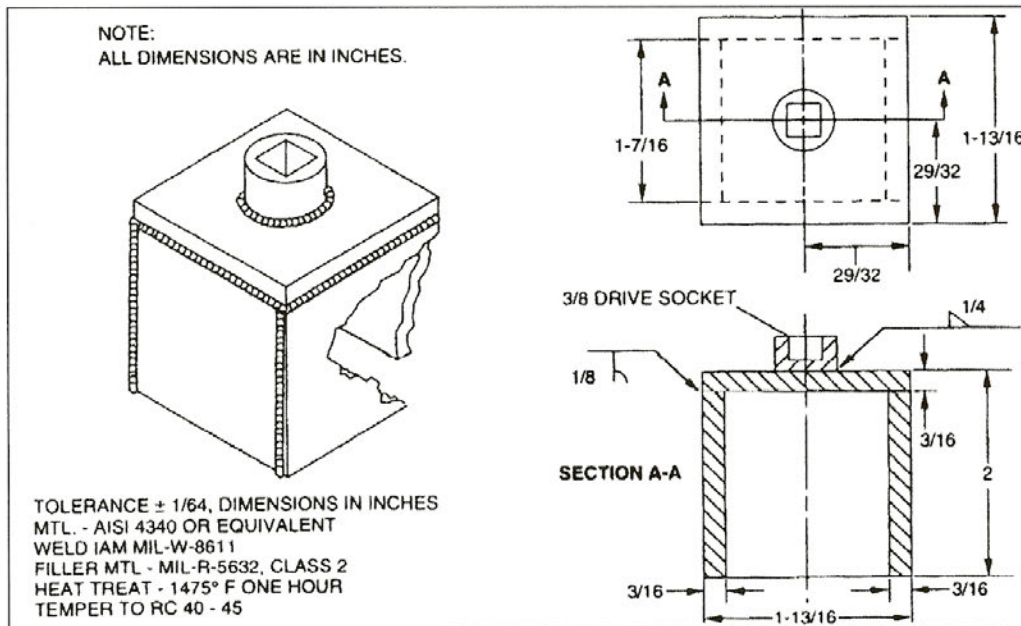

Figure 2. Static Fuel Filter Bowl Removal and Installation Tool.

FIGURE 6. Example of a local manufacturing and assembly work package - Continued.

## MIL-STD-3001-4A(AS)

|   |                                  |   |                          |
|---|----------------------------------|---|--------------------------|
| <b>A1-E2CA-QEC-000</b>  |                                  | <b>006 00</b>   |                          |
| 15 June 1988  |                                  |   |                          |
| <b>INTERMEDIATE MAINTENANCE</b>   |                                  |   |                          |
| <b>QUICK ENGINE CHANGE UNIT (QECU) REDUCTION GEAR — BUILDUP</b>   |                                  |   |                          |
| <b>E-2C (T56-A-425)</b>   |                                  |   |                          |
| <b>Reference Material</b>   |                                  |   |                          |
| Introduction .....  |                                  | WP 002 00   |                          |
| General Information.....  |                                  | WP 003 00   |                          |
| <b>Record of Applicable Technical Directives</b>  |                                  |   |                          |
| <b>TD</b>   | <b>TD Date</b>                   | <b>Title and EPC/RAMEC Number</b>   | <b>Date Incorporated</b> |
| <b>Type/Number</b>  |                                  |   | <b>Remarks</b>           |
| AFC 352   | 02/01/86                         | Deactivation of Propeller Gearbox<br>Vibration Monitoring System (RAMEC<br>17-85) | 06/15/88<br>-            |
| <b>Support Equipment Required</b>   |                                  |   |                          |
| <b>Nomenclature</b>   |                                  | <b>Part Number</b>  | <b>CAGE Code</b>         |
| Torque Wrench   |                                  | 0 to 100 inch-pounds (0 to 20 N-m)  | —                        |
| Torque Wrench   |                                  | 0 to 250 inch-pounds (0 to 30 N-m)  | —                        |
| <b>Materials Required</b>   |                                  |   |                          |
| <b>Nomenclature</b>   |                                  | <b>Specification/Part Number</b>  | <b>HMWS Index Number</b> |
| Lockwire  |                                  | MS20995NC32   | —                        |
| <b>1-1. INTRODUCTION.</b>   |                                  |   |                          |
| 1-2. This work package (WP) provides buildup procedures for the reduction gearbox. The reduction gearbox is part of the E-2C (T56-A-425) turboprop engine. Refer to WP 002 00 for sequence of engine buildup. Refer to WP 003 00 for general information. |                                  |   |                          |
| <b>2-1. REDUCTION GEAR FRONT HOUSING — COMPONENT INSTALLATION.</b>  |                                  |   |                          |
| <b>2-2. NEGATIVE TORQUE BRACKET ASSEMBLY.</b>   |                                  |   |                          |
| <b>Table 1. Buildup Components Required</b>   |                                  |   |                          |
| Figure/Index No.  | Nomenclature                     | Part Number   | Qty                      |
| 2/1   | Negative Torque Bracket Assembly | 753790-1  | 1                        |
| 2/2   | Screw                            | *   | 3                        |
| 2/3   | Washer                           | *   | 3                        |
| *Supplied with negative torque bracket assembly.  |                                  |   |                          |
| 1   |                                  |   |                          |

FIGURE 7. Example of a power plant build-up work package.

## MIL-STD-3001-4A(AS)

**A1-E2CA-QEC-000****006 00**

1. (QA) Position negative torque bracket assembly (31, figure 1) on negative torque bracket assembly mounting pad (6) on reduction gear front housing. Insert three screws (2, figure 2) and washers (3) through negative torque bracket assembly and into reduction gear front housing. Torque screws to 40 to 50 inch-pounds (4.5 to 5.6 N•m) and lockwire.
2. (QA) Adjust adjusting screw (4) to obtain 0.006 to 0.015 inch (0.152 to 0.381 mm), 0.008 inch (0.203 mm) optimum clearance between reduction gear plunger (5) and adjusting screw (4).

**2-3. TORQUE RETAINER (ANTI-ROTATION BRACKET).****Table 2. Buildup Components Required**

| Figure/Index No. | Nomenclature                            | Part Number | Qty |
|------------------|---|-------------|-----|
| 1/12             | Bolt                                    | *           | 2   |
| 1/30             | Torque Retainer (Anti-Rotation Bracket) | 543641      | 1   |

\*Supplied with torque retainer.

1. Position torque retainer (anti-rotation bracket) (30, figure 1) on torque retainer (anti-rotation bracket) mounting pad (7).
2. (QA) Secure torque retainer (anti-rotation bracket) (30) to torque retainer (anti-rotation bracket) mounting pad (7) with two bolts (12). Torque bolts to 155 to 165 inch-pounds (17.5 to 18.6 N•m) and lockwire bolts.

FIGURE 7. Example of a power plant build-up work package - Continued.

## MIL-STD-3001-4A(AS)

A1-E2CA-QEC-000

006 00

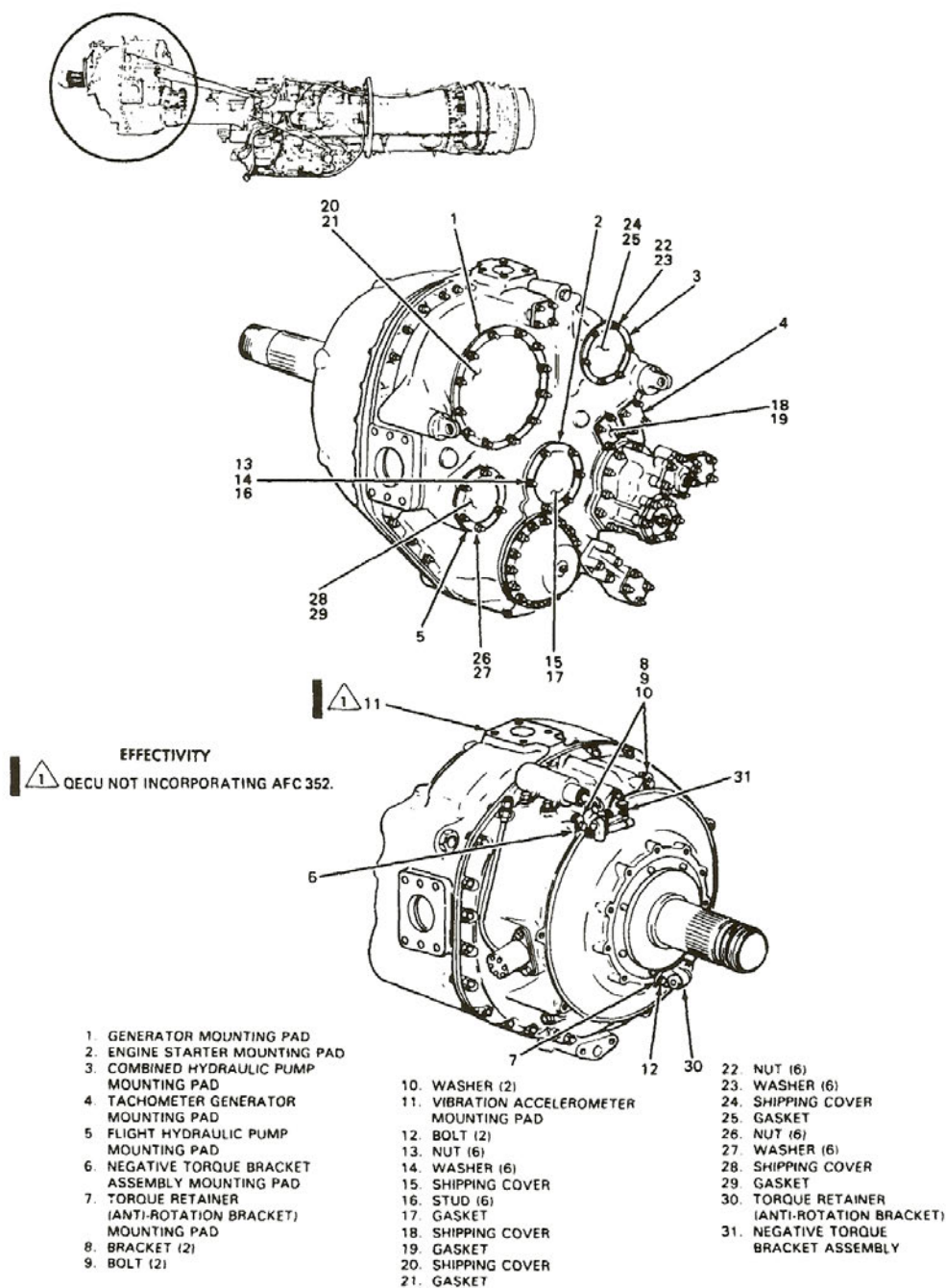

Figure 1. Reduction Gear - Component Mounting Locations.

3

FIGURE 7. Example of a power plant build-up work package - Continued.

MIL-STD-3001-4A(AS)

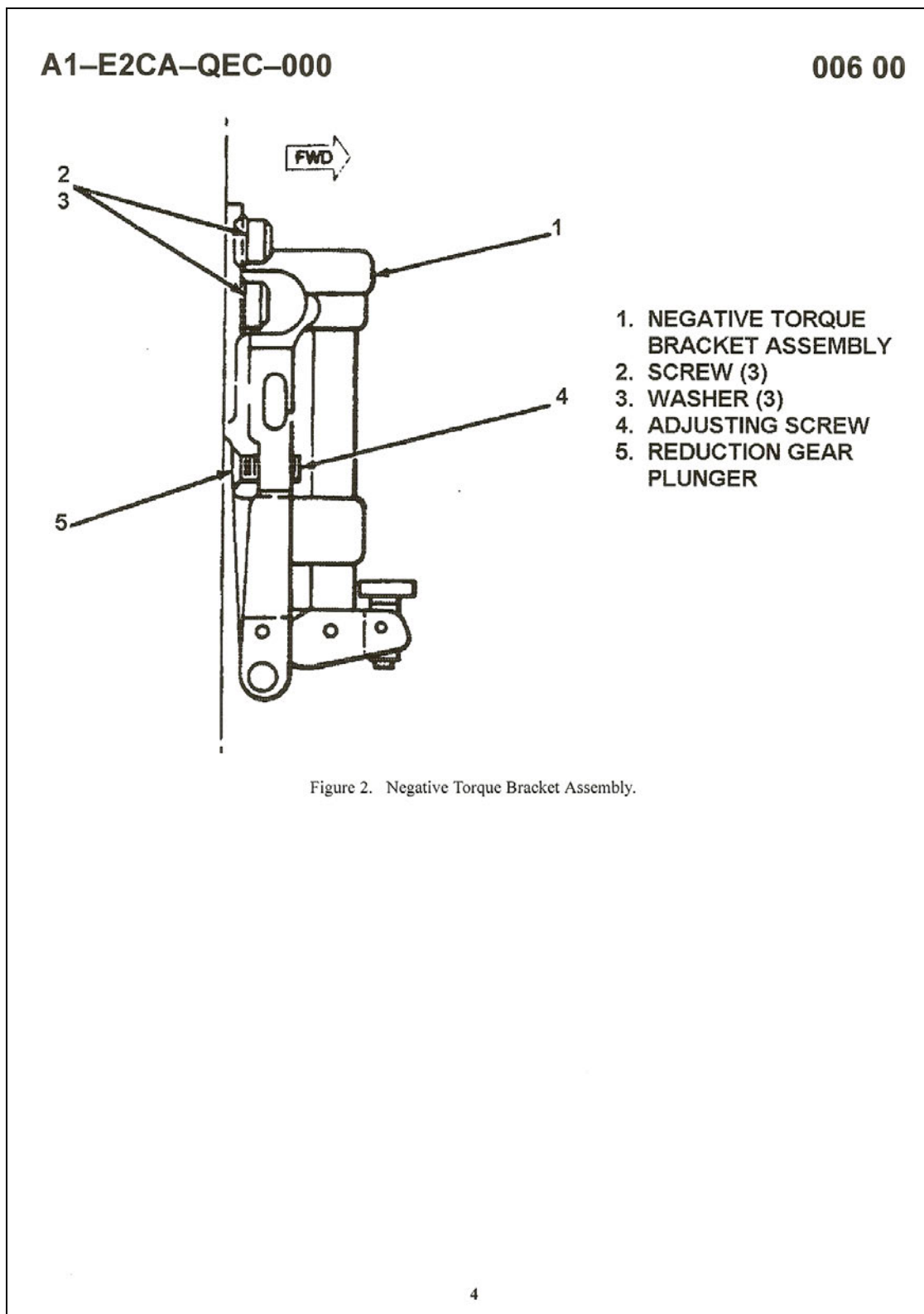

FIGURE 7. Example of a power plant build-up work package - Continued.

## MIL-STD-3001-4A(AS)

| REPORTED / CONFIRMED DEFECTS   | PROBABLE CAUSE  | CORRECTIVE ACTION  |
|--|---|--|
| 1. LP compressor, foreign object damage (FOD) / native object damage (NOD) | a. FOD: ingestion of harmful material (stones, gravel, birds, etc.) into engine<br>b. NOD: broken engine components (blade, disk, nut, bolt, bearing failure, etc.) | Perform maintenance tasks in table 2 as required to correct defect |
| 2. HP compressor FOD / NOD (rotor replacement not required)                | a. FOD: ingestion of harmful material (stones, gravel, birds, etc.) into engine<br>b. NOD: broken engine components (blade, disk, nut, bolt, bearing failure, etc.) | Perform maintenance tasks in table 2 as required to correct defect |
| 3. HP compressor FOD / NOD (rotor replacement required)                    | a. FOD: ingestion of harmful material (stones, gravel, birds, etc.) into engine<br>b. NOD: broken engine components (blade, disk, nut, bolt, bearing failure, etc.) | Perform maintenance tasks in table 2 as required to correct defect |
| 4. HP / LP turbine NOD   | Broken engine components (blade, disk, nut, bolt, bearing failure, etc.)  | Perform maintenance tasks in table 2 as required to correct defect |
| 5. Engine overtemperature  | a. Hot stagnated engine start on the ground or in the air<br>b. Unscheduled overfueling during flight or ground running   | Perform maintenance tasks in table 2 as required to correct defect |

FIGURE 8. Example of a probable cause / corrective action table.

MIL-STD-3001-4A(AS)

| TABLE 2. MANDATORY/RECOMMENDED MAINTENANCE TASKS |   |              | COMPLETE ENGINE REPAIR<br>(CER) | LP COMPRESSOR FOD/NOD | HP COMPRESSOR FOD/NOD<br>(Rotor replacement not required) | HP COMPRESSOR FOD/NOD<br>(Rotor replacement required) | HP/LP TURBINE NOD | ENGINE OVERTEMPERATURE | LOW HOVER PERFORMANCE<br>(High-JPT/low thrust) |
|--|---|--------------|---------------------------------|-----------------------|---|---|-------------------|------------------------|--|
| TASK No.   | TASK  | WORK PACKAGE |                                 |                       |   |   |                   |                        |  |
| 1.   | Inspect engine externaly for cracks, corrosion, fretting, oil leaks, fuel leaks, general condition, hose pressure dates and missing components: use visual (white-light) method (WP 007) of inspection. Record all defects and determine corrective actions to be performed.  |              | X                               | X                     | X   | X   | X                 | X                      | X  |
| 2.   | Inspect LP compressor internally (as far as possible) for general damage. If damage is found perform tasks listed under LP COMPRESSOR FOD/NOD.  |              |                                 |                       | X   |   |                   |                        | X  |
|  | <p style="text-align: center;"><b>WARNING</b></p> <p>Exercise extreme care when turning the rotor; the small clearances and considerable momentum could cause injury to personnel or damage equipment.</p> <p>Hand-turn LP compressor rotor assembly using hand-turning gear; be sure that rotor is not binding and listen for abnormal noises. If either, or both of these conditions exist, perform tasks listed under LP COMPRESSOR ROTOR SHAFT ASSEMBLY BINDING FAST RUNDOWN TIMES.</p> |              | X                               |                       |   |   |                   |                        | X  |
|  | Rotate HP compressor rotor assembly using hand-turning gear; be sure that rotor is not binding and listen for abnormal noises. If either, or both of these conditions exist, perform tasks listed under HP COMPRESSOR ROTOR BALANCED REPAIRABLE ASSEMBLIES BINDING FAST RUNDOWN TIMES.  | 042 00       | X                               |                       |   |   |                   |                        | X  |

FIGURE 9. Example of a mandatory/recommended maintenance tasks table.

## MIL-STD-3001-4A(AS)

**A1-720XX-MMI-000**

15 June 1996

**004 00**

---

**INTERMEDIATE MAINTENANCE  
NUMERICAL INDEX OF PART NUMBERS TO SEQUENCE  
F424 - W - 406 AIRCRAFT ENGINE**

---

**1-1 INTRODUCTION**

1-2 This work package contains the numerical index of external engine parts by part number, cross referenced to their installation sequence number. Once an installation number is known, refer to WP 005 00 to locate part and figure keys to locate applicable zone(s) for installation information.

| PN     | SEQUENCE | PN     | SEQUENCE |
|--------|----------|--------|----------|
| 659561 | (42)     | 672491 | (139)    |
| 659563 | (110)    | 672493 | (138)    |
| 659564 | (5)      | 675755 | (54)     |
| 659566 | (43)     | 675757 | (53)     |
| 659567 | (10)     | 676007 | (46)     |
| 659575 | (57)     | 676962 | (91)     |
| 659585 | (7)      | 677672 | (67)     |
| 659590 | (61)     | 678943 | (27)     |
| 661397 | (102)    | 678945 | (38)     |
| 661399 | (100)    | 678948 | (115)    |
| 661459 | (92)     | 679047 | (20)     |
| 661617 | (116)    | 679799 | (129)    |
| 661622 | (79)     | 679804 | (130)    |
| 661645 | (72)     | 679806 | (131)    |

FIGURE 10. Example of a numerical index work package.



## MIL-STD-3001-4A(AS)

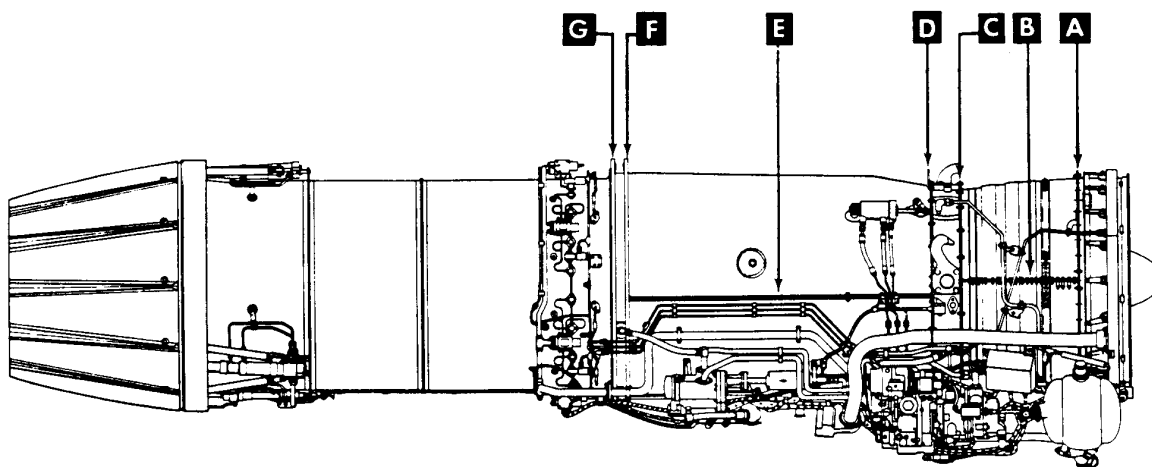

| FLANGE   |   | TORQUE VALUES                   |                          | FIG. NO. |
|----------|---|---------------------------------|--------------------------|----------|
|          |   | LB IN.                          | LB FT.                   |          |
| <b>A</b> | FRONT FRAME-TO-FAN STATOR CASE              | 105-115                         | 9-10                     | 2        |
| <b>B</b> | FAN STATOR CASE SPLITLINE                   | 105-115;<br>270-290;<br>380-400 | 1-10;<br>23-25;<br>31-33 | 3        |
| <b>C</b> | FAN STATOR CASE-TO-MIDFRAME                 | 105-115                         | 9-10                     | 3        |
| <b>D</b> | MIDFRAME-TO-OUTER BYPASS DUCT               | 150-160                         | 12-13                    | 4        |
| <b>E</b> | OUTER BYPASS DUCT SPLITLINE                 | 150-160                         | 12-13                    | 5        |
| <b>F</b> | OUTER BYPASS DUCT-TO-ENGINE REAR MOUNT RING | 230-245                         | 19-20                    | 6        |
| <b>G</b> | ENGINE REAR MOUNT RING-TO-AFTERBURNER       | 270-290                         | 23-25                    | 7        |

FIGURE 11. Example of a bracket installation.

MIL-STD-3001-4A(AS)

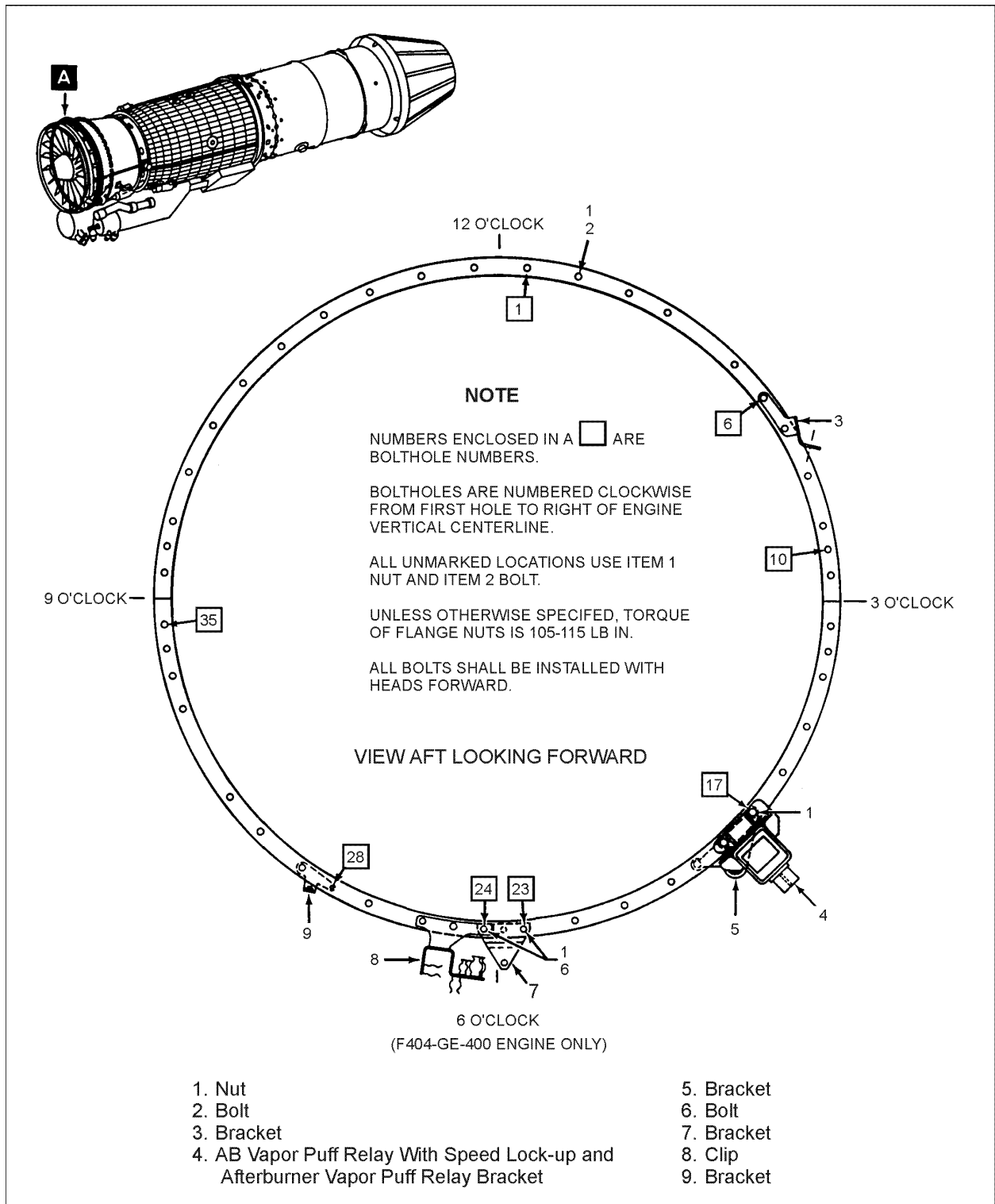

FIGURE 11. Example of a bracket installation - Continued.

MIL-STD-3001-4A(AS)

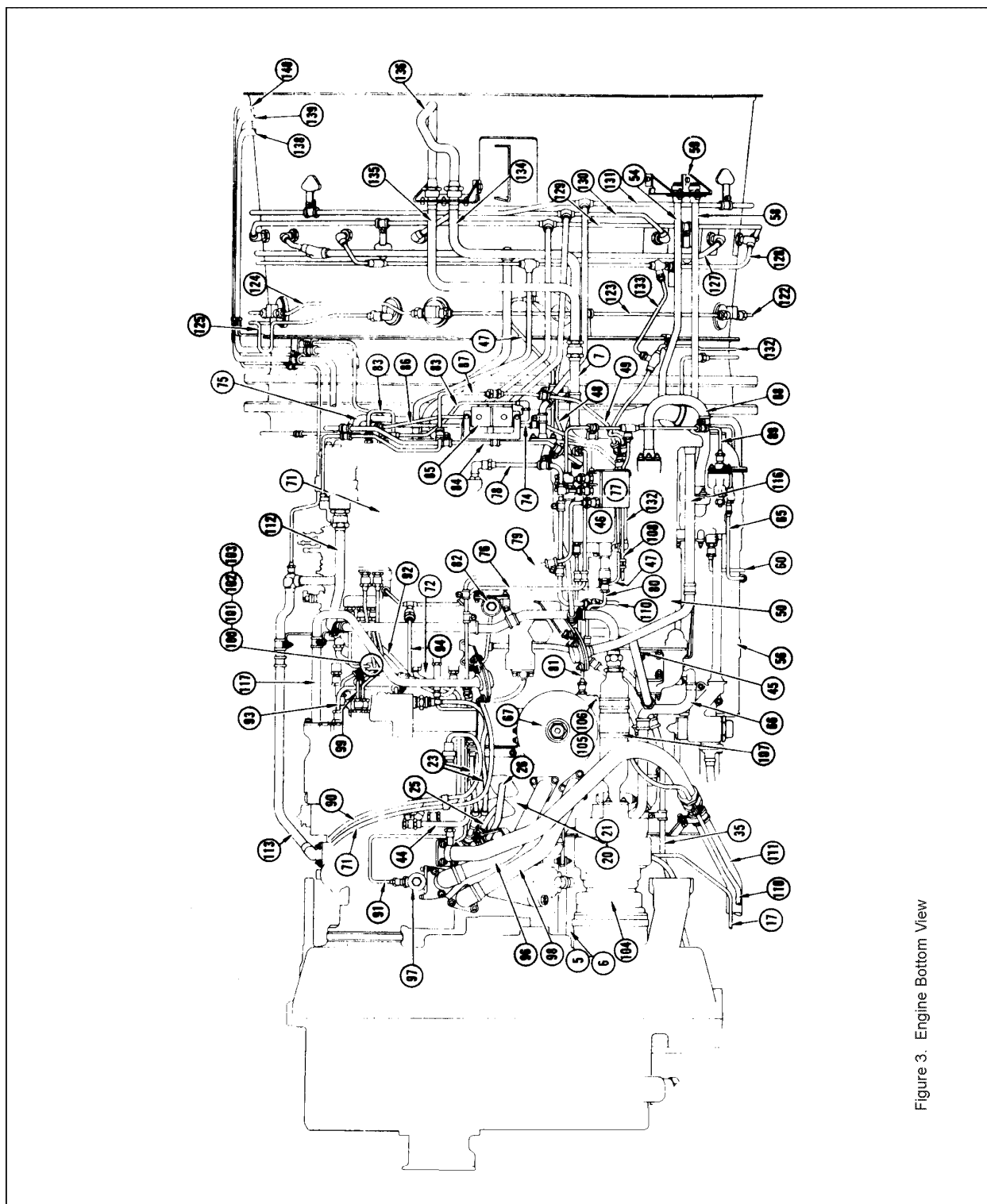

Figure 3. Engine Bottom View

FIGURE 12. Example of external tubing, cabling, and clamping installation.

## MIL-STD-3001-4A(AS)

## KEY TO FIGURE 1 (CONT.)

| SEQUENCE | PN                 | NOMENCLATURE  | ZONE FIGURES   |
|----------|--------------------|---|----------------|
| ①24      | 585543             | Left P <sub>t</sub> 7 tube lower (rear P <sub>t</sub> 7/T <sub>t</sub> 7 junctions) | 15, 16, 26     |
| ①25      | 585547             | P <sub>t</sub> 7 manifold (P <sub>t</sub> 7 forward system)                         | 15, 16, 17, 23 |
| ①26      | 628189             | No. 6 bearing oil pressure tubing   | 17, 22, 23     |
| ①27      | ★ 679809           | AB manifold, Zone 4   | 15, 16, 17, 22 |
| ①28      | ★ 679828<br>731434 | AB manifold, Zone 1   | 16, 17, 22, 26 |
| ①29      | ★ 679799           | AB manifold, Zone 2   | 16, 17, 23     |
| ①30      | ★ 679804           | AB manifold, Zone 3   | 22, 23, 26     |
| ①31      | ★ 679806           | AB manifold, Zone 5   | 17, 22, 23     |
| ①32      | 728048             | AB sensing manifold   | 15, 22         |
| ①34      | 666382             | Airframe oil cooler tube (upper right)  | 15, 22, 23     |
| ①35      | 666385             | Airframe oil cooler tube (lower left)   | 26             |
| ①36      | 618171             | Airframe oil cooler bypass tube   | 15, 16, 17     |
| ①37      | 648233             | P <sub>t</sub> 7tube (to ENC)   | 15, 16, 17, 26 |
| ①38      | 672493             | AB nozzle open tube   | 22, 26         |
| ①39      | 672491             | AB nozzle close tube  | 17, 23         |
| ①40      | 672489             | AB nozzle coolant (drain) tube  | 15, 16, 22     |

## NOTE

★ items indicate critical clearances must be maintained. See WP006 00 for specific areas.

FIGURE 12. Example of external tubing, cabling, and clamping installation - Continued.

MIL-STD-3001-4A(AS)

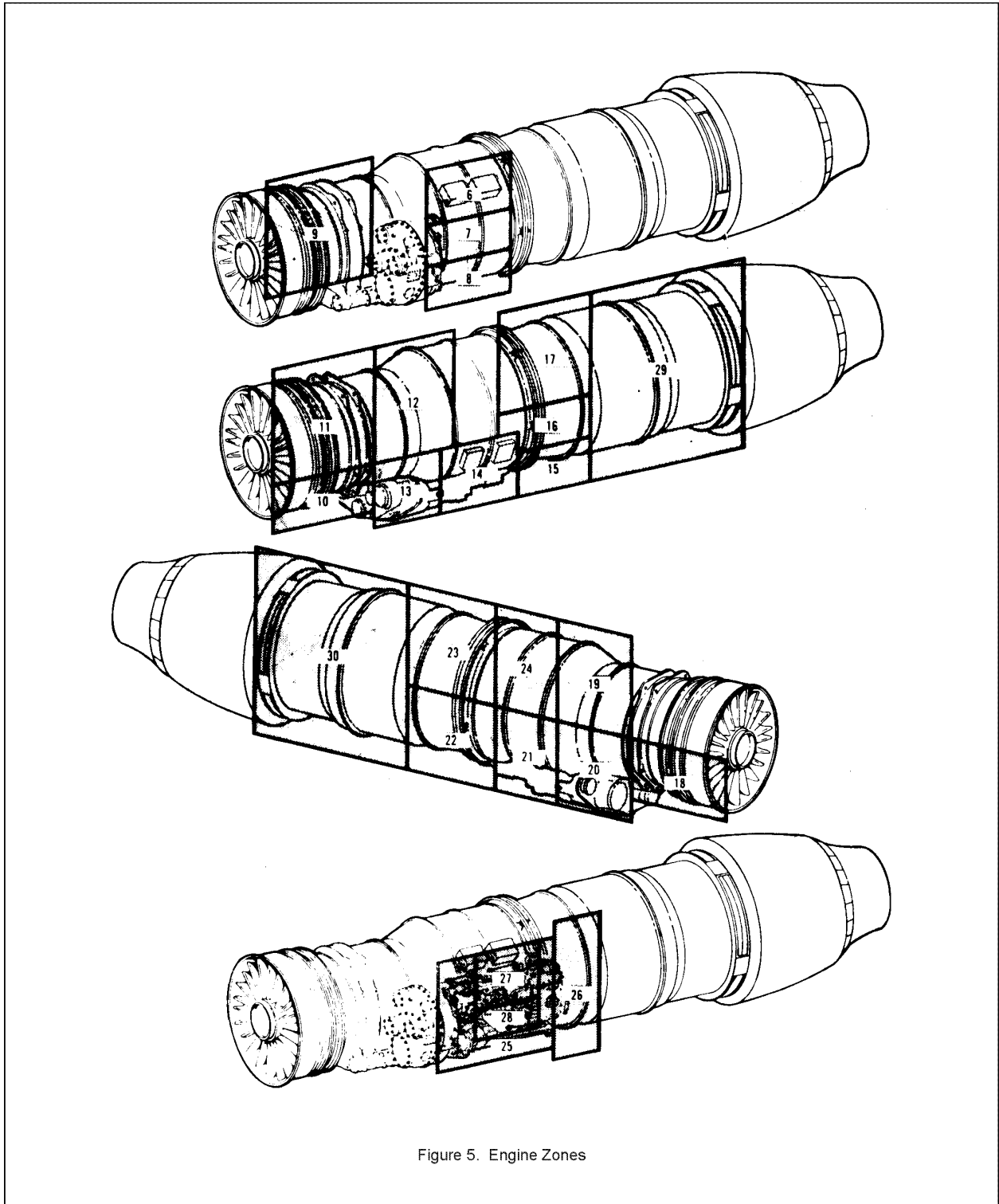

Figure 5. Engine Zones

FIGURE 12. Example of external tubing, cabling, and clamping installation - Continued.

MIL-STD-3001-4A(AS)

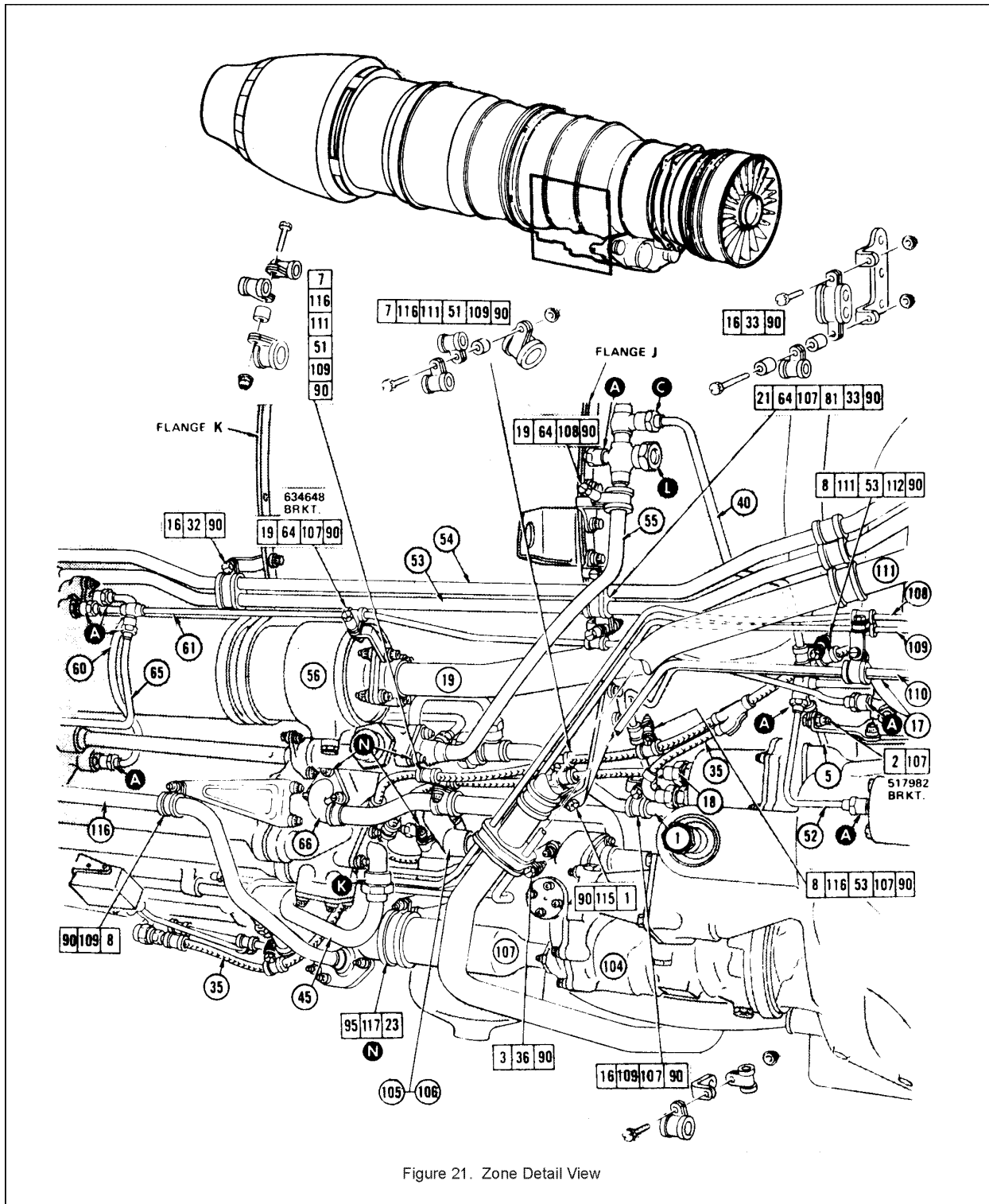

FIGURE 12. Example of external tubing, cabling, and clamping installation - Continued.

## MIL-STD-3001-4A(AS)

## KEY TO FIGURE 21

| INDEX CODE | PN               | NAME             | SPECIFICATIONS                 |
|------------|------------------|------------------|--------------------------------|
| 1          | 545962           | Screw            | 0.500 inch long                |
| 2          | 504578           | Screw            | 0.562 inch long                |
| 3          | 511105           | Screw            | 0.483 inch long                |
| 7          | 496366           | Screw            | 0.875 inch long                |
| 8          | 545964           | Screw            | 0.625 inch long                |
| 16         | 546286           | Screw            | 0.562 inch long                |
| 19         | 564738           | Screw            | 1.062 inch long                |
| 21         | 528085           | Screw            | 1.500 inch long                |
| 23         | 566462           | Screw            | 0.625 inch long (1/4 X 28)     |
| 32         | 567164<br>523824 | Clamp<br>Cushion | Qty (2)                        |
| 33         | 581862<br>523824 | Clamp<br>Cushion | Qty (2)<br>Qty (2)             |
| 36         | 523993<br>523992 | Clamp<br>Cushion |                                |
| 51         | 510275           | Spacer           | 0.238 inch long, 0.438 inch OD |
| 90         | 488589           | Nut              |                                |
| 95         | 564705           | Nut              |                                |
| 107        | 310612           | Loop clamp       |                                |
| 108        | 310622           | Loop clamp       |                                |
| 109        | 310623           | Loop clamp       |                                |
| 111        | 310614           | Loop clamp       |                                |
| 112        | 310621           | Loop clamp       |                                |
| 115        | 310630           | Loop clamp       |                                |
| 116        | 310637           | Loop clamp       |                                |
| 117        | 641689           | Loop clamp       |                                |
| A          |                  | Torque           | 90 - 100 lb-in.                |
| C          |                  | Torque           | 270 - 300 lb-in.               |
| K          |                  | Torque           | 900 - 1000 lb-in.              |
| L          |                  | Torque           | 200 - 200 lb-in.               |
| N          |                  | Torque           | 75 - 85 lb-in.                 |

## NOTE

All clamp screws/nuts, torque 36 - 40 pound-inches unless otherwise specified.

FIGURE 12. Example of external tubing, cabling, and clamping installation - Continued.

MIL-STD-3001-4A(AS)

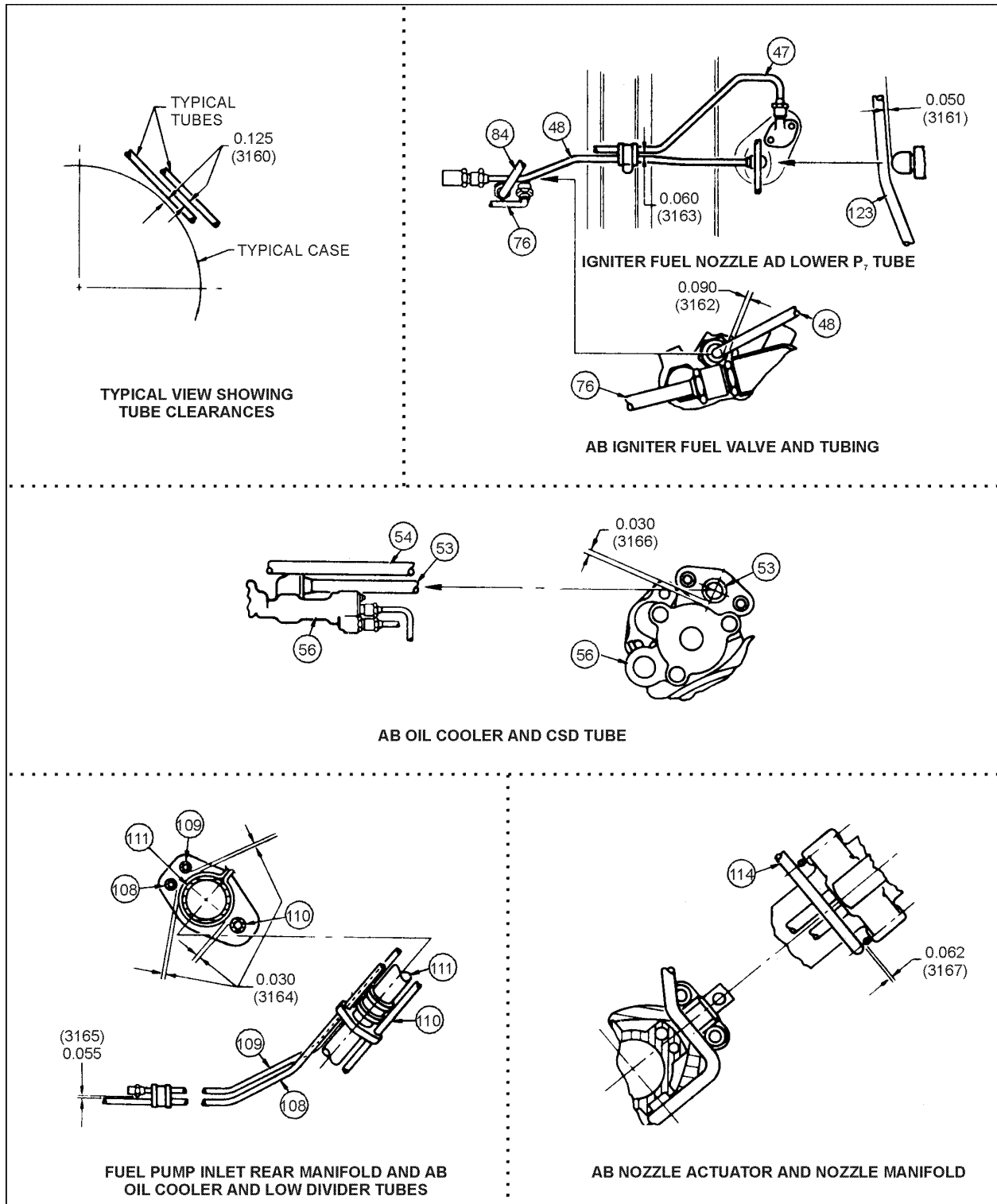

FIGURE 13. Example of critical clearances.



MIL-STD-3001-4A(AS)

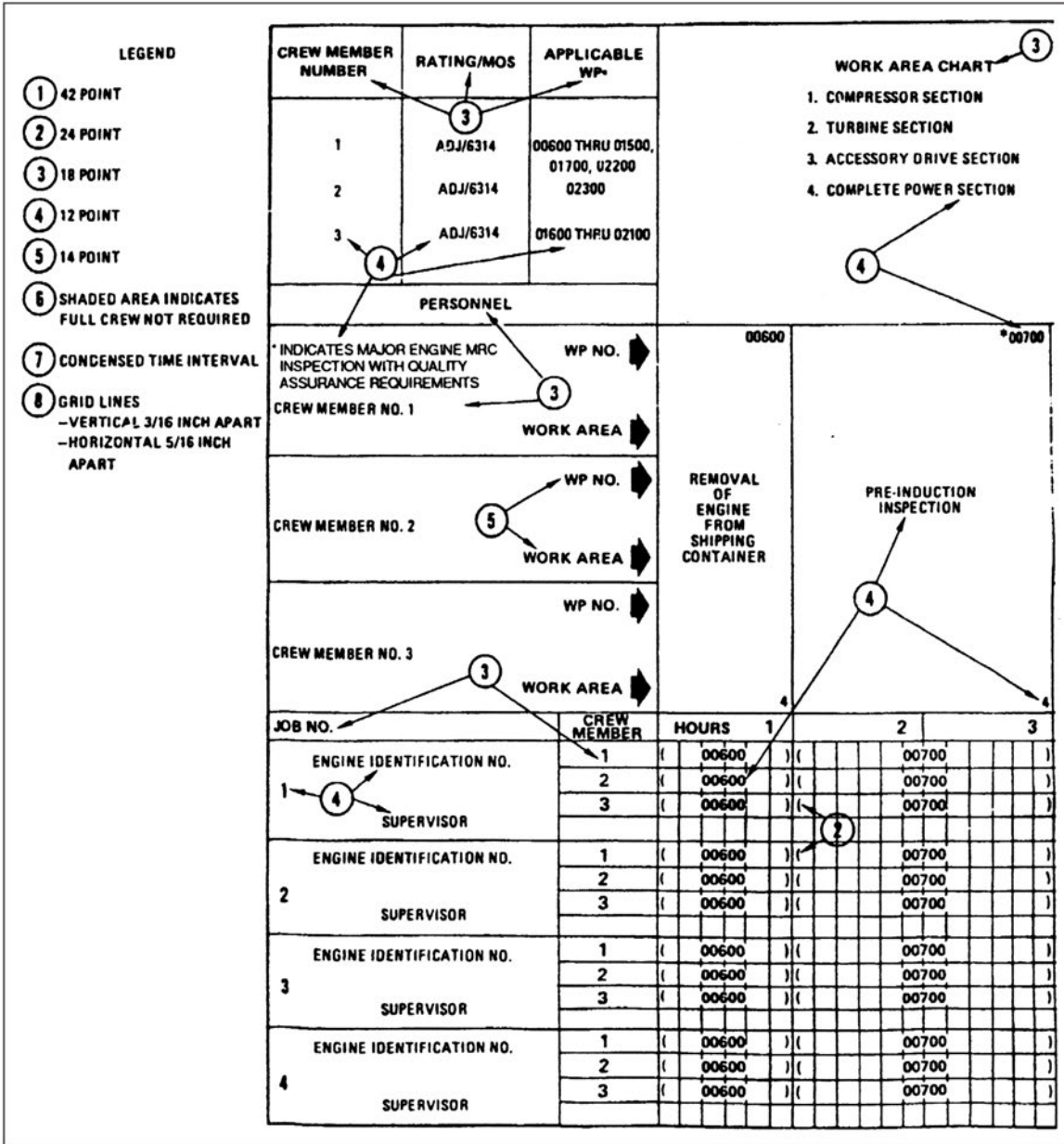

FIGURE 14. Example of sequence control chart.

MIL-STD-3001-4A(AS)

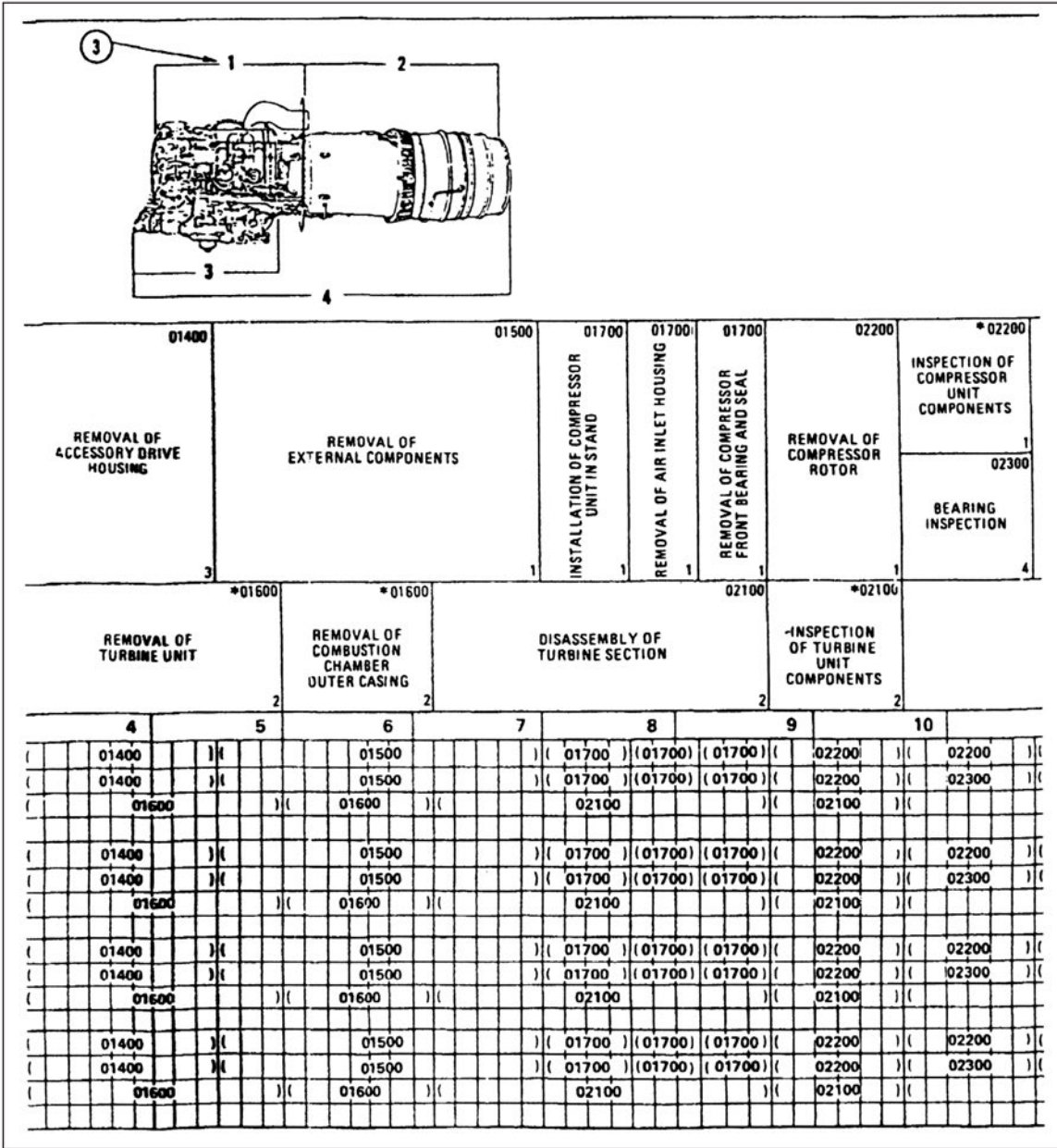

FIGURE 14. Example of sequence control chart - Continued.

MIL-STD-3001-4A(AS)

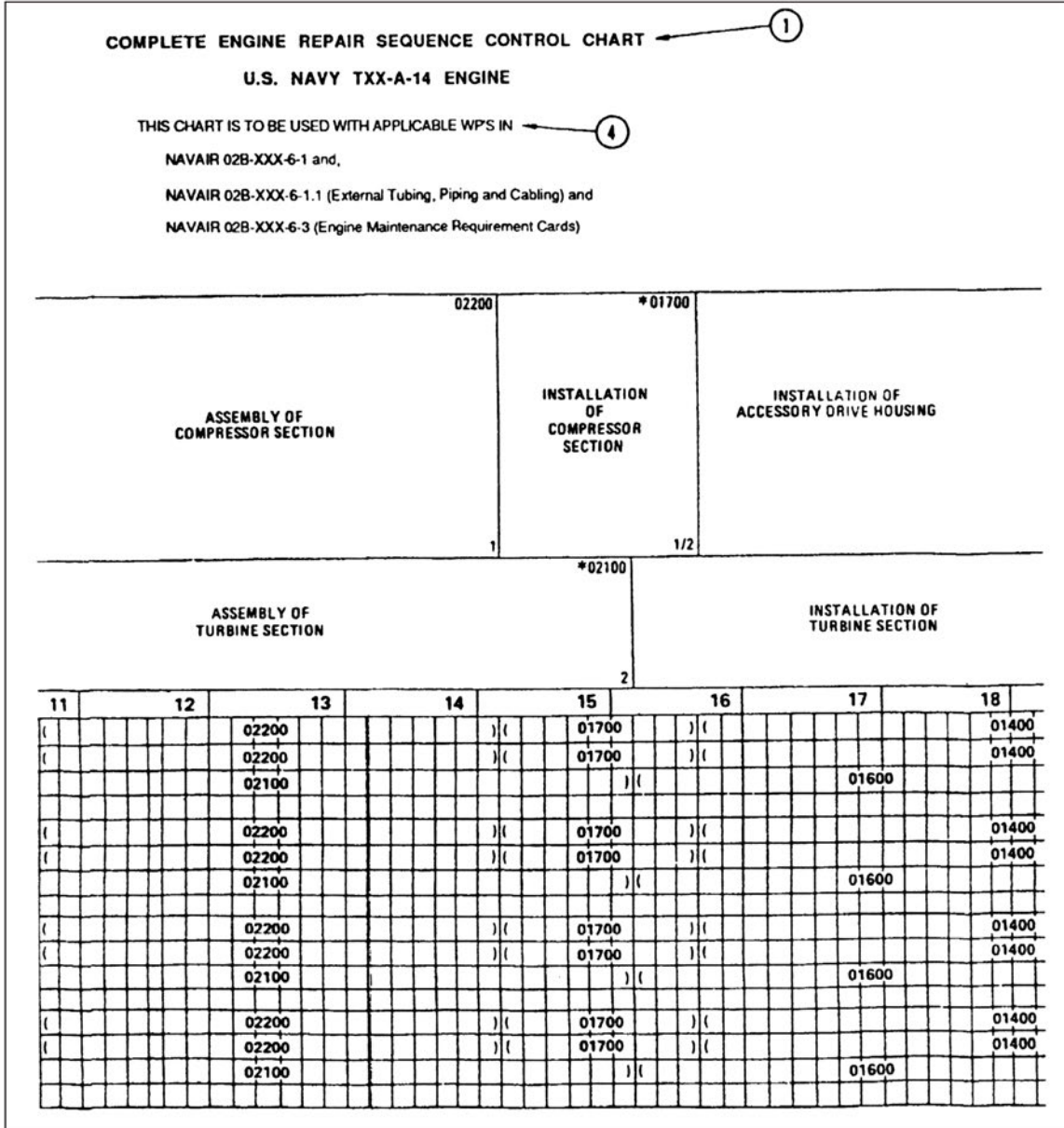

FIGURE 14. Example of sequence control chart - Continued.

MIL-STD-3001-4A(AS)

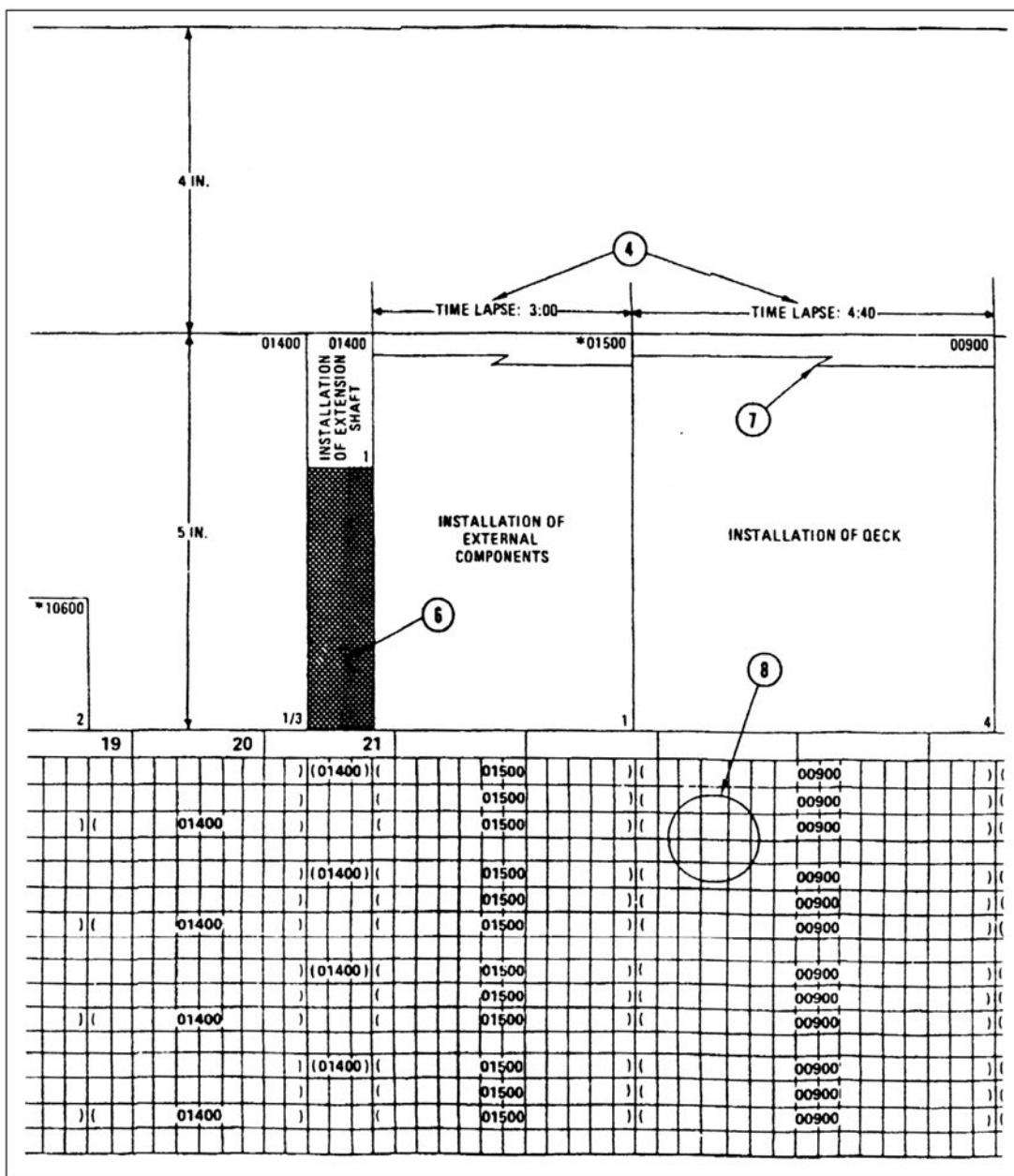

FIGURE 14. Example of sequence control chart - Continued.

MIL-STD-3001-4A(AS)

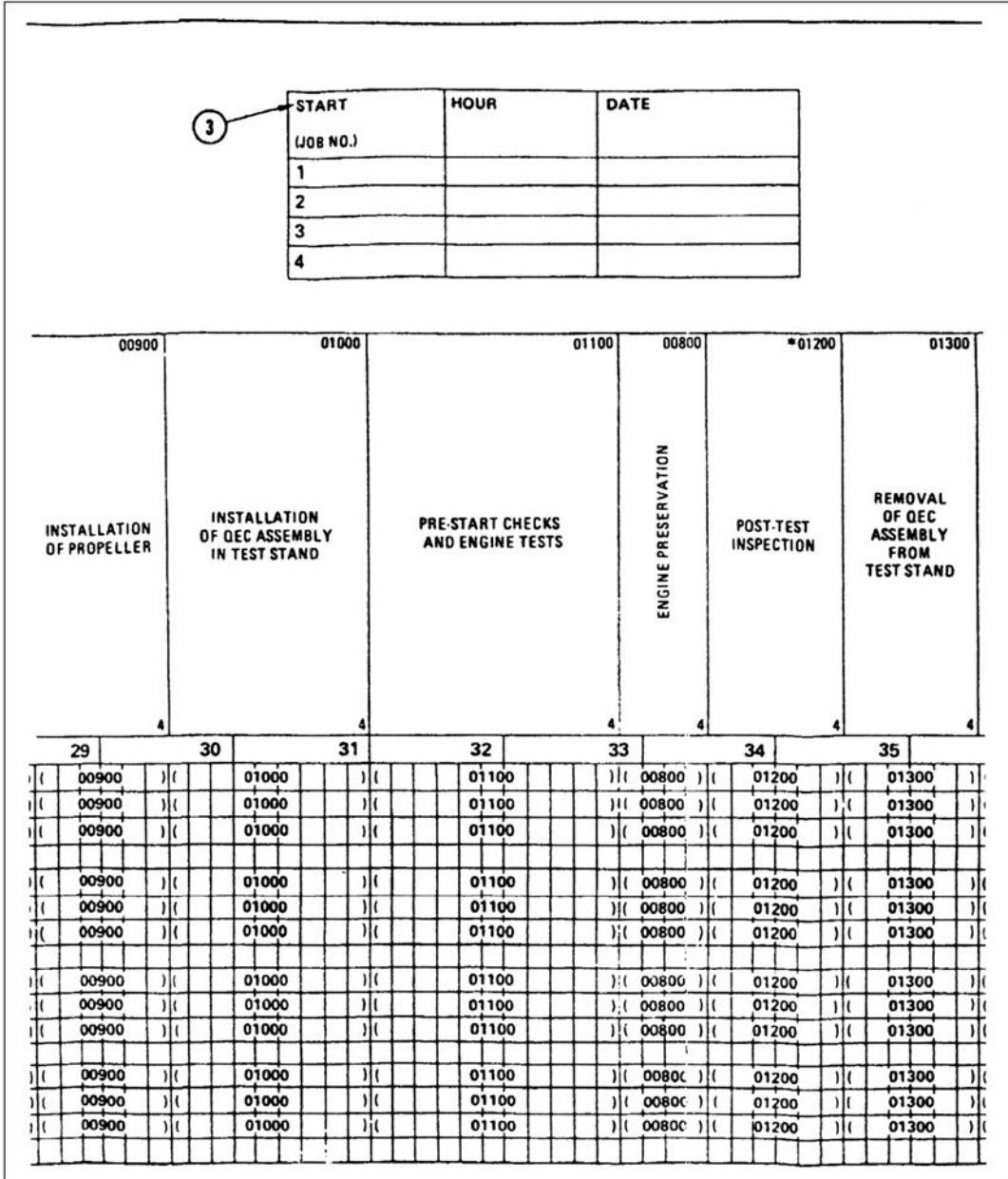

FIGURE 14. Example of sequence control chart - Continued.

MIL-STD-3001-4A(AS)

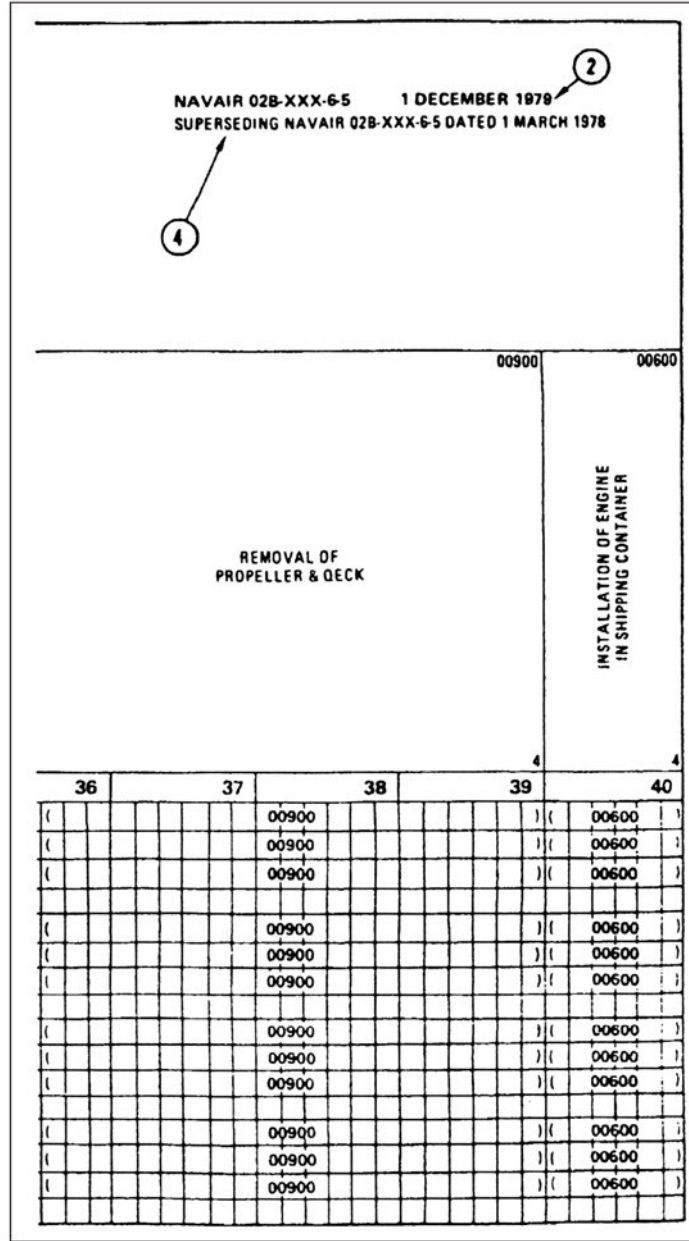

FIGURE 14. Example of sequence control chart - Continued.

MIL-STD-3001-4A(AS)

CONCLUDING MATERIAL

Custodian:  
Navy - AS

Preparing activity:  
Navy - AS  
(Project TMSS-2014-017)

NOTE: The activity listed above was interested in this document as of the date of this document. Since organizations and responsibilities can change, you should verify the currency of the information above using the ASSIST Online database at <https://assist.dla.mil>.