

**NOT MEASUREMENT
SENSITIVE**

**MIL-STD-3001-1A(AS)
w/CHANGE 1
01 December 2016
SUPERSEDING
MIL-STD-3001-1A(AS)
10 October 2014**

DEPARTMENT OF DEFENSE STANDARD PRACTICE

PREPARATION OF DIGITAL TECHNICAL INFORMATION FOR MULTI-OUTPUT PRESENTATION OF TECHNICAL MANUALS

(PART 1 OF 8 PARTS)



MIL-STD-3001-1A(AS) w/CHANGE 1

FOREWORD

1. This standard is approved for use by the Department of the Navy and is available for use by all Departments and Agencies of the Department of Defense.
2. This eight-part standard establishes the requirements needed to prepare digital technical information for multi-output presentation of NAVAIR work package (WP) Technical Manuals (TMs). The technical content and style and format requirements contained in this eight-part standard can be used to develop and assemble complete TMs for aircraft weapon systems, aeronautical equipment, airborne weapons/equipment, training systems, and support equipment WP TMs. The requirements are applicable for the output of printed paper and PDF screen displayed TMs. The requirements are also applicable for the display of Interactive Electronic Technical Manuals (IETMs) on any viewer that supports MIL-STD-3001-1.
3. MIL-STD-3001-1 is Part 1 of 8 parts and is incomplete without Parts 2 through 8. Part 1 contains general preparation requirements for the multi-output presentation of NAVAIR WP TMs. Appendix A of Part 1 contains matrixes that list all applicable technical content requirements for the development of complete TMs for aircraft weapon systems, aeronautical equipment, airborne weapons/equipment, training systems, and support equipment covering operation and maintenance at all maintenance levels through depot. Appendix B of Part 1 establishes the style, format, and front matter requirements necessary to assemble and print complete WP TMs in a page-oriented format. Appendix C of Part 1 establishes presentation requirements for the display of frame-based and scrollable TMs. Appendix D of Part 1 provides graphics (illustrations) guidelines and examples of the types of graphics used in NAVAIR TMs.
4. MIL-STD-3001-2 through MIL-STD-3001-8 contain specific functional technical content requirements for the preparation of all NAVAIR WP TMs and revisions. Parts 2 through 8 are identified below:

MIL-STD-3001-2	Description, Principles of Operation, and Operation Data
MIL-STD-3001-3	Testing and Troubleshooting Procedures
MIL-STD-3001-4	Maintenance Information with Illustrated Parts Breakdown (IPB)
MIL-STD-3001-5	Aircraft Wiring Information
MIL-STD-3001-6	Structural Repair Information
MIL-STD-3001-7	Periodic Maintenance Requirements
MIL-STD-3001-8	Illustrated Parts Breakdown (IPB)

5. Comments, suggestions, or questions on this document should be addressed to the Naval Air Systems Command (Commander, Naval Air Warfare Center Aircraft Division Lakehurst, Code 4.1.2.2, Route 547, Mail Stop 120-3, Joint Base MDL, NJ 08733-5100) or emailed to michael.sikora@navy.mil. Since contact information can change, you may want to verify the currency of this address information using the ASSIST online database at <https://assist.dla.mil>.

MIL-STD-3001-1A(AS) w/CHANGE 1

SUMMARY OF CHANGE 1 MODIFICATIONS

1. The requirements for the Numerical Index of Part Numbers (NIPN) work package were changed to allow the option to include Group Assembly Parts list (GAPL) part numbers listed in Attaching Parts in the NIPN work package. Added requirements for Training Systems. Added “Third Party Agreement” requirements for Technical Manuals (TMs) and Periodic Maintenance Requirements Card and Checklist title pages. Document Type Definition (DTD) tags were updated. Replaced figures to reflect current requirements and format. Editorial and format changes were made to text.

2. The following modifications to MIL-STD-3001-1A have been made:

Part/Paragraph	Modification
1-Foreword	Added
1-1.1	Added
1-3.1	Changed
1-4.3b	Added
1-5.1b	Changed
1-5.2	Added
1-6.1	Added
1-6.5	Changed
1-A.1.1b	Added
1-A.5.1	Changed
1-A.5.1a	Added
1-A.5.1b	Added
1-A.5.1c	Changed
1-A.5.1d	Changed
1-A.5.2	Changed
1-Table A-III	Changed
1-Table A-IV	Changed
1-Table A-XIII	Changed
1-Table A-XIV	Changed
1-Table A-XV	Changed
1-Table A-XVI	Changed
1-Table A-XVII	Changed
1-Table A-XVIII	Changed
1-Table A-XIX	Changed
1-Table A-XX	Changed
1-Table A-XXI	Changed
1-Table A-XXII	Changed

MIL-STD-3001-1A(AS) w/CHANGE 1

Part/Paragraph	Modification
1- Table A-XXIII	Changed
1-Table A-XXIV	Changed
1-Table A-XXV	Changed
1-Table A-XXVI	Changed
1-Table A-XXVII	Changed
1-Table A-XXIX	Changed
1-Table A-XXX	Added
1-Table A-XXXI	Changed
1-Table A-XXXII	Changed
1-Table A-XXXIII	Changed
1-Table A-XXXIV	Changed
1-Table A-XXXV	Added
1-Table A-XXXVI	Changed
1-B.1.1	Added
1-B.4.2.1	Added
1-B.5.2	Changed
1-B.5.3k	Added
1-B.5.3.1.1n	Added
1-B.5.3.1.1.2i	Added
1-B.5.3.1.1.3h	Added
1-B.5.3.1.1.3m	Changed
1-B.5.3.2.1.3.1c	Changed
1-B.5.3.2.1.3.6	Added
1-B.5.3.2.1.3f	Added
1-B.5.4.2	Changed
1-B.5.4.7.6	Changed
1-B.5.4.7.15.1.3	Changed
1-B.5.8.8	Added
1-Figure B-1	Changed
1-Figure B-2	Changed
1-Figure B-3	Changed
1-Figure B-4	Changed
1-Figure B-5	Changed
1-Figure B-6	Changed
1-Figure B-7	Changed
1-Figure B-8	Changed
1-Figure B-9	Changed

MIL-STD-3001-1A(AS) w/CHANGE 1

Part/Paragraph	Modification
1-Figure B-10	Changed
1-Figure B-11	Changed
1-Figure B-12 sheets 1 and 2	Changed
1-Figure B-13	Changed
1-Figure B-14 sheets 1 through 5	Changed
1-Figure B-15	Changed
1-Figure B-20 sheets 1 and 2	Changed
1-Figure B-21 sheets 1 and 2	Changed
1-C.5.2a	Added
1-C.5.4	Added
1-C.5.4g	Added
1-C.5.4.2b	Added
1-C.5.4.9	Added

MIL-STD-3001-1A(AS) w/CHANGE 1

CONTENTS

<u>PARAGRAPH</u>	<u>PAGE</u>
1. SCOPE	1
1.1 Scope.....	1
2. APPLICABLE DOCUMENTS.....	1
2.1 General.....	1
2.2 Government documents	1
2.2.1 Specifications, standards, and handbooks.....	1
2.2.2 Other Government documents and publications.....	2
2.3 Non-Government publications.....	5
2.4 Order of precedence	7
3. DEFINITIONS	7
3.1 Acronyms used in this standard	7
3.2 Definitions of selected terms.....	11
4. GENERAL REQUIREMENTS.....	21
4.1 General.....	21
4.2 Technical manual classifications	21
4.2.1 Organizational level.....	21
4.2.2 Intermediate and depot levels	21
4.2.3 Combined maintenance levels	21
4.3 Types of technical manuals.....	22
4.4 Maintenance level applicability	22
4.5 Selective application and tailoring.....	22
4.6 Style and format.....	23
4.7 Preparation of digital data for electronic delivery	23
4.8 Development of an XML source file	23
4.9 Use of the modular DTDs.....	23
4.10 Obtaining the modular DTDs.....	23
4.11 Standard tables and lists.....	24
4.12 Conflict between standards	24
4.13 Figures contained in this standard.....	24
4.14 Copyrights, proprietary names, and advertising	24
4.14.1 Copyright/copyright credit line.....	24
4.14.2 Proprietary names	24
4.14.3 Advertising.....	24
5. DETAILED REQUIREMENTS.....	24
5.1 Development of technical information	24
5.2 Work package development.....	25
5.2.1 Types of work packages.....	25

MIL-STD-3001-1A(AS) w/CHANGE 1

CONTENTS

<u>PARAGRAPH</u>	<u>PAGE</u>
5.3 Task analysis	26
5.3.1 Technical manual outline	26
6. NOTES	26
6.1 Intended use	26
6.2 Acquisition requirements	26
6.3 Tailoring guidance	26
6.4 Subject term (key word) listing.....	26
6.5 Changes from previous issue	27
APPENDIX A - TECHNICAL MANUAL CONTENT SELECTION MATRIXES.....	28
A.1 SCOPE	28
A.1.1 Scope	28
A.2 APPLICABLE DOCUMENTS.....	28
A.3 DEFINITIONS	29
A.4 GENERAL REQUIREMENTS.....	29
A.5 DETAILED REQUIREMENTS.....	29
A.5.1 General	29
A.5.2 Intended use	30
A.5.3 Acquisition requirements	30
APPENDIX B - PREPARATION REQUIREMENTS FOR PAGE-BASED PRINTED AND SCREEN DISPLAYED PDF TECHNICAL MANUALS.....	91
B.1 SCOPE.....	91
B.1.1 Scope	91
B.2 APPLICABLE DOCUMENTS	91
B.3 DEFINITIONS	91
B.4 GENERAL REQUIREMENTS	91
B.4.1 General	91
B.4.2 Development of technical information.....	91
B.4.2.1 Work package development	91
B.5 DETAILED REQUIREMENTS.....	91
B.5.1 General	91
B.5.2 Mandatory requirements	92
B.5.3 Front matter and supporting information organization	92
B.5.3.1 Front matter	92
B.5.3.1.1 Title page <titlepg>	92
B.5.3.1.1.1 Title page - classified work package manuals.....	95

MIL-STD-3001-1A(AS) w/CHANGE 1

CONTENTS

<u>PARAGRAPH</u>	<u>PAGE</u>
B.5.3.1.1.2 Title and cover cards (Periodic Maintenance Requirements Card Set Decks only).....	95
B.5.3.1.1.3 Checklist title page <fmcl>	97
B.5.3.1.2 Numerical index of effective work packages/pages (A page) <niewp>.....	99
B.5.3.1.2.1 List of current revisions.....	99
B.5.3.1.2.2 List of effective cards <lecds>.....	100
B.5.3.1.3 Technical publication deficiency reports (TPDR) incorporated pages <tpdrpg>	100
B.5.3.1.3.1 Development of the technical publication deficiency reports incorporated.....	100
B.5.3.1.3.2 Technical publication deficiency reports (TPDR) incorporated cards (Periodic Maintenance Requirements Card Set Decks only).....	100
B.5.3.1.4 Hazardous Materials Warning Summary (HMWS) work package <hmwswp>	101
B.5.3.1.4.1 Explanation of hazardous materials icons	101
B.5.3.1.4.2 Warnings applicable to hazardous materials card (HMWS card) (Periodic Maintenance Requirements Card Set Decks only).	101
B.5.3.1.4.2.1 Hazardous materials referenced in text	102
B.5.3.1.5 Alphabetical index work package <alphaindwp>	102
B.5.3.1.5.1 Development of the alphabetical index work package.....	103
B.5.3.1.6 Alphabetical index work package <alphaindwp> for multivolume TMs.....	103
B.5.3.2 Supporting information	104
B.5.3.2.1 Work package content.....	104
B.5.3.2.1.1 Title block <titleblk>.....	104
B.5.3.2.1.2 Fault isolation title block <fititleblk>.....	105
B.5.3.2.1.3 Required technical support information.....	105
B.5.3.2.1.3.1 Numerical index of part numbers work package <partnoindwp>.....	106
B.5.3.2.1.3.2 Numerical index of reference designations work package <refdesindwp>	107
B.5.3.2.1.3.3 Introduction work packages <introwp>	108
B.5.3.2.1.3.3.1 Introductory information for structural repair, corrosion control, and nondestructive inspection information.....	110
B.5.3.2.1.3.3.2 Introductory information for testing and troubleshooting procedures	111
B.5.3.2.1.3.3.3 Introductory information for illustrated parts breakdown (IPB) data	111
B.5.3.2.1.3.3.4 Introductory information for illustrated parts breakdown (IPB) manuals..	112
B.5.3.2.1.3.4 Consolidated lists for technical directives, support equipment, materials, and references work package <consolistwp>.....	112
B.5.3.2.1.3.4.1 Historical record of applicable technical directives <hratd>	112
B.5.3.2.1.3.4.2 Consolidated list of support equipment required <sereq>.....	113
B.5.3.2.1.3.4.3 Consolidated list of materials required <matreq>.....	114
B.5.3.2.1.3.4.4 Consolidated list of reference material <refmat>.....	114

MIL-STD-3001-1A(AS) w/CHANGE 1

CONTENTS

<u>PARAGRAPH</u>	<u>PAGE</u>
B.5.3.2.1.3.5 Maintenance allocation work package <maintalwp> (engine intermediate maintenance only)	114
B.5.3.2.1.3.6 Safety summary work package <safewp> (training systems only)	114
B.5.4 Style and format guidelines	114
B.5.4.1 Printed manuals	114
B.5.4.1.1 Page size of reproducible copy.....	115
B.5.4.1.2 Image area of reproducible copy	115
B.5.4.1.3 Authorized printed manual size by thickness.....	115
B.5.4.2 Type sizes and styles	116
B.5.4.3 Text development and placement.....	119
B.5.4.4 Placement of graphics	119
B.5.4.5 Marginal copy	119
B.5.4.6 Equations	120
B.5.4.7 Writing guidelines	121
B.5.4.7.1 Abbreviations and acronyms <abbrevlist>	121
B.5.4.7.2 Warnings, cautions, and notes.....	121
B.5.4.7.2.1 Format for warnings, cautions, and notes.....	121
B.5.4.7.3 Quality assurance procedures	122
B.5.4.7.4 Health hazard precaution data	122
B.5.4.7.4.1 Warnings applicable to hazardous materials	122
B.5.4.7.4.2 Hazardous materials referenced in text	123
B.5.4.7.5 Nuclear hardness	123
B.5.4.7.5.1 Hardness critical symbols.....	123
B.5.4.7.6 Electrostatic discharge (ESD) sensitive parts.....	123
B.5.4.7.7 Ozone depleting substances (ODS).....	123
B.5.4.7.8 Nomenclature consistency.....	124
B.5.4.7.8.1 Noun modifiers.....	124
B.5.4.7.8.2 Neutral terms	124
B.5.4.7.8.3 Military terms	124
B.5.4.7.8.4 Automatic electronic test and checkout terminology.....	124
B.5.4.7.8.5 Placard data	125
B.5.4.7.8.6 Designation of equipment	125
B.5.4.7.8.7 National stock numbers	125
B.5.4.7.8.8 Part numbers and reference designations	125
B.5.4.7.9 Symbols	125
B.5.4.7.10 Footnotes	126
B.5.4.7.11 References	126
B.5.4.7.11.1 Mandatory compliance maintenance procedures	126
B.5.4.7.11.2 Maintenance procedures contained in other manuals	126

MIL-STD-3001-1A(AS) w/CHANGE 1

CONTENTS

<u>PARAGRAPH</u>	<u>PAGE</u>
B.5.4.7.11.3 Tasks performed by other work centers	126
B.5.4.7.11.4 Quality assurance referencing	126
B.5.4.7.11.5 References to other manuals or volumes.....	127
B.5.4.7.11.6 References within a manual or volume	127
B.5.4.7.12 Typeface and type size	127
B.5.4.7.13 Numbering.....	127
B.5.4.7.13.1 Numerical index of effective work packages/pages (A page).....	127
B.5.4.7.13.2 Technical Publications Deficiency Reports (TPDR) incorporated pages	128
B.5.4.7.13.3 Warnings applicable to hazardous materials page(s)	128
B.5.4.7.13.4 Work package number	128
B.5.4.7.13.4.1 Work package numbering system	128
B.5.4.7.13.4.2 WP number assignment.....	128
B.5.4.7.13.4.3 Reserved WP numbers	128
B.5.4.7.13.4.4 Deleted WP numbers.....	129
B.5.4.7.13.4.5 Work package numbers - division into volumes.....	129
B.5.4.7.13.4.6 Work package page numbers	129
B.5.4.7.13.4.7 Work package foldout page numbers.....	129
B.5.4.7.13.4.8 Work package foldout figure numbers.....	129
B.5.4.7.13.5 Paragraph numbering	129
B.5.4.7.13.6 Procedural step numbers	130
B.5.4.7.14 Format for tables and lists	131
B.5.4.7.14.1 Table locations	131
B.5.4.7.14.2 Table numbering.....	131
B.5.4.7.14.3 Table titles	131
B.5.4.7.14.4 Table format	131
B.5.4.7.14.5 Footnotes to tables.....	132
B.5.4.7.14.6 Table readability and use.....	132
B.5.4.7.15 Lists	132
B.5.4.7.15.1 Wire list	133
B.5.4.7.15.1.1 Aircraft wire run list.....	133
B.5.4.7.15.1.2 Wiring reference designation list	133
B.5.4.7.15.1.4 Placement of wire run lists	133
B.5.4.7.15.2 List format	133
B.5.4.7.16 Format for figures/illustrations.....	133
B.5.4.7.16.1 Figure numbering	133
B.5.4.7.16.2 Figure titles.....	134
B.5.4.7.16.3 Legends	134
B.5.6 Changes/Revisions	134
B.5.6.1 Changes for TMs.....	134

MIL-STD-3001-1A(AS) w/CHANGE 1

CONTENTS

<u>PARAGRAPH</u>	<u>PAGE</u>
B.5.6.1.1 Change numbers	135
B.5.6.1.2 Renumbering in a work package	135
B.5.6.2 Change symbols	136
B.5.6.2.1 Change symbols for text and tables.....	136
B.5.6.2.2 Change symbols for illustrations.....	137
B.5.6.3 Pickup revisions	137
B.5.6.4 Complete revisions	137
B.5.6.5 Supersedure notice	137
B.5.6.5.1 Title page supersedure notice	137
B.5.6.5.2 WP title block supersedure notice.....	137
B.5.7 Comprehensibility	137
B.5.8 Security classification markings.....	138
B.5.8.1 General	138
B.5.8.2 Overall classification.....	138
B.5.8.3 Classification of alphabetical index	138
B.5.8.4 Classification of work packages.....	138
B.5.8.5 Classification of pages	138
B.5.8.6 Paragraph and table markings	139
B.5.8.7 Illustration markings	139
B.5.8.8 Downgrading/Declassification	139
APPENDIX C - PREPARATION REQUIREMENTS FOR INTERACTIVE ELECTRONIC TECHNICAL MANUALS	165
C.1 SCOPE	165
C.1.1 Scope	165
C.2 APPLICABLE DOCUMENTS.....	165
C.3 DEFINITIONS	165
C.4 GENERAL REQUIREMENTS	165
C.4.1 General	165
C.4.2 Development of work package IETMs	165
C.4.2.1 Use of style sheets	165
C.4.2.2 Use of a viewer other than NSIV	165
C.4.3 IETM definitions	166
C.4.3.1 Linear structured IETM.....	166
C.4.3.2 Hierarchical structured IETM	166
C.4.3.3 Integrated process IETM	166
C.4.3.4 Other types of IETMs.....	166

MIL-STD-3001-1A(AS) w/CHANGE 1

CONTENTS

<u>PARAGRAPH</u>	<u>PAGE</u>
C.5 DETAILED REQUIREMENTS.....	166
C.5.1 General	166
C.5.1.1 Level of detail.....	166
C.5.2 IETM divisions.....	167
C.5.3 Front matter	167
C.5.3.1 CD label and flyleaf data.....	168
C.5.3.2 Title page data	168
C.5.3.3 Revision summary data <revision-summary-info>	168
C.5.3.4 Table of contents	168
C.5.3.4.1 Display of the table of contents	168
C.5.3.4.2 Use of work package numbers	168
C.5.3.5 "How to Use this IETM" information <how-to-use-etm>	168
C.5.3.5.1 Display of "How to Use This IETM" information	169
C.5.3.6 Acronyms and abbreviations list <abbrevlist>	169
C.5.3.7 Effectivity information	169
C.5.4 Supporting information work packages <supportinfo>	169
C.5.4.1 Hazardous Materials Warning Summary (HMWS) <hmwswp>	170
C.5.4.1.1 Explanation of hazardous materials icons	170
C.5.4.2 Consolidated numerical index of part numbers work package <partnoindxwp>	170
C.5.4.3 Consolidated numerical index of reference designations work package <refdesindxwp>	170
C.5.4.4 Historical record of applicable technical directives <hratd>	171
C.5.4.5 Consolidated list of support equipment required <sereq>	171
C.5.4.6 Consolidated list of materials required <matreq>	171
C.5.4.7 Consolidated list of reference material <refmat>	171
C.5.4.8 Maintenance allocation work package <maintalwp> (engine intermediate maintenance only)	171
C.5.5 Style, format and display of work packages.....	172
C.5.5.1 Work packages	172
C.5.5.1.1 Work package content.....	172
C.5.5.1.2 Work package title	172
C.5.5.1.3 Work package initial setup information	172
C.5.5.2 Work package text and graphics	172
C.5.5.2.1 Abbreviations and acronyms	172
C.5.5.2.2 Nomenclature	172
C.5.5.2.2.1 Nomenclature consistency.....	172
C.5.5.2.2.2 Noun modifiers.....	173
C.5.5.2.2.3 Military terms	173
C.5.5.2.2.4 Automatic electronic test and checkout terminology.....	173

MIL-STD-3001-1A(AS) w/CHANGE 1

CONTENTS

<u>PARAGRAPH</u>	<u>PAGE</u>
C.5.5.2.2.5 Placard data	173
C.5.5.2.2.6 Designation of equipment	173
C.5.5.2.3 National stock numbers	173
C.5.5.2.4 Part numbers.....	173
C.5.5.2.5 Symbols	173
C.5.5.2.6 Footnotes	173
C.5.5.2.7 References	174
C.5.5.2.7.1 Mandatory compliance maintenance procedures	174
C.5.5.2.7.2 Maintenance procedures contained in other manuals.....	174
C.5.5.2.7.3 Tasks performed by other work centers	174
C.5.5.2.7.4 Post maintenance action referencing.....	174
C.5.5.2.7.5 References to other manuals or volumes.....	175
C.5.5.2.7.6 Referencing within the IETM.....	175
C.5.5.2.8 Equations	175
C.6 GRAPHICS REQUIREMENTS.....	175
C.6.1 Display of illustrations	175
C.7 REVISIONS AND UPDATES	175
C.7.1 Revisions and updates	175
C.7.1.1 Revisions	175
C.7.1.2 Updates.....	176
C.7.1.3 Change data/symbols.....	176
C.8 COMPREHENSIBILITY	176
C.9 SECURITY CLASSIFICATION REQUIREMENTS AND MARKINGS	176
C.9.1 Classified IETMs.....	176
C.9.2 Security classification markings.....	176
C.9.2.1 Display of security classification markings	176
APPENDIX D - GRAPHICS GUIDELINES AND EXAMPLES OF TYPES OF GRAPHICS USED IN WORK PACKAGE TECHNICAL MANUALS.....	177
D.1 SCOPE	177
D.1.1 Scope.....	177
D.2 APPLICABLE DOCUMENTS.....	177
D.3 DEFINITIONS	177
D.4 GENERAL REQUIREMENTS.....	177
D.4.1 Illustration preparation	177
D.4.1.1 Requirements for digital graphics files	177
D.4.1.2 Illustration style and format preparation.....	177

MIL-STD-3001-1A(AS) w/CHANGE 1

CONTENTS

<u>PARAGRAPH</u>	<u>PAGE</u>
D.4.1.2.1 Illustrations for the support of procedural data	177
D.4.1.2.2 Multiple use of illustrations	178
D.4.1.2.3 Illustration preparation for tools and test equipment	178
D.4.1.2.4 Electronic items.....	178
D.4.1.3 Illustration detail and size	178
D.4.1.3.1 Illustration detail	178
D.4.1.3.2 Line drawings quality.....	179
D.4.1.3.3 Scale	179
D.4.1.3.4 Letter size	179
D.4.1.3.5 Electrostatic discharge (ESD) sensitive acronym	180
D.4.2 Elements of illustrations.....	180
D.4.2.1 Border rules and boxes.....	180
D.4.2.2 Use of the human figure.....	180
D.4.2.3 Use of locator and detail views	180
D.4.2.3.1 Locator views	180
D.4.2.3.2 Detail views.....	180
D.4.2.4 Credit lines	180
D.4.2.5 Callouts	181
D.4.2.5.1 Index number callouts.....	181
D.4.2.5.2 Nomenclature callouts.....	182
D.4.2.5.3 Reference designator callouts	182
D.4.2.6 Legends	182
D.4.2.7 Leader lines and arrowheads	182
D.4.2.8 Sweep arrows	183
D.4.2.9 Color in illustrations.....	183
D.4.2.9.1 Page-based TMs	183
D.4.2.9.2 Frame-based TMs	183
D.5 DETAILED REQUIREMENTS	183
D.5.1 Types of illustrations.....	183
D.5.1.1 Photographs.....	183
D.5.1.1.1 Prescreened photographs.....	184
D.5.1.2 Engineering drawings	184
D.5.1.3 Multiview illustrations (page-based TMs only)	184
D.5.1.4 Foldout and multisheet illustrations (page-based TMs only).....	185
D.5.1.5 Exploded view illustrations.....	185
D.5.1.6 Cartoons	186
D.5.1.7 Pictorial illustrations	186
D.5.1.8 Combination illustrations	187

MIL-STD-3001-1A(AS) w/CHANGE 1

CONTENTS

<u>PARAGRAPH</u>	<u>PAGE</u>
D.5.1.9 Charts and graphs as illustrations.....	187
D.5.1.9.1 Line graphs.....	187
D.5.1.10 Diagrams	188
D.5.1.10.1 General preparation requirements.....	188
D.5.1.10.2 Specification requirements.....	188
D.5.1.10.3 General methods	188
D.5.1.10.4 Signal flow	190
D.5.1.10.4.1 Signal connections	190
D.5.1.10.4.1.1 Techniques within a single sheet of a diagram	190
D.5.1.10.4.1.2 Techniques between sheets of a diagram	191
D.5.1.10.4.1.3 Techniques between diagrams	192
D.5.1.10.4.2 Signal difference	192
D.5.1.10.4.3 Signal junctions.....	192
D.5.1.10.5 Schematic and functional flow diagrams	192
D.5.1.10.5.1 Circuit parameters	194
D.5.1.10.5.2 Test point identification symbols	194
D.5.1.10.5.3 Use of artificial test points	194
D.5.1.10.5.4 Components shown on schematic diagrams	195
D.5.1.10.6 Functional diagrams	195
D.5.1.10.7 Cutaway diagrams.....	196
D.5.1.10.8 Combination diagrams	196
D.5.1.10.9 Logic diagrams.....	196
D.5.1.10.10 Simplified diagrams	196
D.5.1.10.11 Partial diagrams.....	197
D.5.1.10.12 Test diagrams	197
D.5.1.10.13 Power distribution diagrams	197
D.5.1.10.14 Pyramid diagrams.....	197
D.5.1.10.15 Wiring diagrams/illustrations.....	197
D.5.1.10.15.1 Wiring diagrams.....	197
D.5.1.10.15.1.1 Wire bundle routing illustrations	198
D.5.1.10.16 Cable diagrams.....	198
D.5.1.10.17 Piping diagrams.....	199
D.5.1.10.18 Fluid power/gas diagrams	199
D.5.1.10.18.1 Arrangement of symbols	199
D.5.1.10.18.2 Conductors	199
D.5.1.10.18.2.1 Single lines	200
D.5.1.10.18.2.2 Double lines	200
D.5.1.10.18.2.3 Joining lines	200
D.5.1.10.18.2.4 Crossing lines	200

MIL-STD-3001-1A(AS) w/CHANGE 1

CONTENTS

<u>PARAGRAPH</u>	<u>PAGE</u>
D.5.1.10.19 Component data	200
D.5.1.10.20 Rotation	200
D.5.1.10.21 Direction of flow	201
D.5.1.10.22 Port identification.....	201
D.5.1.10.23 Pattern code.....	201
D.5.1.10.24 Component enclosure.....	201
D.5.1.10.25 Identifying components.....	201

MIL-STD-3001-1A(AS) w/CHANGE 1

CONTENTS

<u>FIGURES</u>	<u>PAGE</u>
FIGURE B-1. Example of a title page.	140
FIGURE B-2. Example of an aircraft, QECA or ALSS card deck title card.	141
FIGURE B-3. Example of an armament/special stores, support equipment or target (surface or aerial) card deck title card.	141
FIGURE B-4. Example of a PSE card deck title card.	142
FIGURE B-5. Example of phase/QEC/ALSS cover cards.	142
FIGURE B-6. Example of a PSE cover card.	143
FIGURE B-7. Example of a title / introduction / application page for checklists.	143
FIGURE B-8. Example of a numerical index of effective work packages/pages.	144
FIGURE B-9. Example of an "A" card.	145
FIGURE B-10. Example of a technical publication deficiency report (TPDR).	146
FIGURE B-11. Example of technical publications deficiency report (TPDR) card.	147
148	
FIGURE B-12. Example of hazardous materials warnings summary.	148
FIGURE B-13. Example of icons applicable to hazardous materials warnings.	150
FIGURE B-14. Example of warnings applicable to hazardous materials card.	151
FIGURE B-15. Example of an alphabetical index work package.	154
FIGURE B-16. Example of an alphabetical index work package for a multi-volume TM.	155
FIGURE B-17. Examples of a work package title block.	156
FIGURE B-18. Example of numerical index of part numbers work package.	157
FIGURE B-19. Example of a numerical index of reference designations work package.	158
FIGURE B-20. Example of consolidated lists of technical directives, support equipment, materials, and references work package.	159
FIGURE B-21. Example of a maintenance allocation work package.	161
FIGURE B-22. Example of a page image area.	163
FIGURE D-1. Example of an electronic component card illustration.	202
FIGURE D-2. Example of multiview, locator view and detail view illustrations.	203
FIGURE D-3. Example of an exploded view.	206
FIGURE D-4. Example of a pictorial.	207
FIGURE D-5. Example of point-to-point and highway method signal flow.	209
FIGURE D-6. Example of oval connectors to continue signals.	210
FIGURE D-7. Example of signal returns and breakoff symbols.	211
FIGURE D-8. Example of boat symbols, numerical identifiers, and pyramid method.	212
FIGURE D-9. Example of signal difference techniques.	213
FIGURE D-10. Example of subordinate and coordinate junctions.	214
FIGURE D-11. Example of a hardware schematic diagram.	215

MIL-STD-3001-1A(AS) w/CHANGE 1

CONTENTS

<u>FIGURES</u>	<u>PAGE</u>
FIGURE D-12. Example of a functional schematic.	216
FIGURE D-13. Example of a functional flow diagram.	217
FIGURE D-14. Example of uncrowded schematic diagram.	218
FIGURE D-15. Example of components drawn on a schematic.	219
FIGURE D-16. Example of a functional block diagram.	220
FIGURE D-17. Example of a cutaway diagram.	221
FIGURE D-18. Example of a logic diagram.	222
FIGURE D-19. Example of a truth table.	223
FIGURE D-20. Example of a timing diagram.	224
FIGURE D-21. Example of a simplified diagram.	225
FIGURE D-22. Example of a partial diagram.	226
FIGURE D-23. Example of a test diagram.	227
FIGURE D-24. Example of a test setup diagram.	228
FIGURE D-25. Example of a power distribution diagram.	230
FIGURE D-26. Example of a pyramid diagram.	231
FIGURE D-27. Example of a wiring diagram.	232
FIGURE D-28. Example of a wiring bundle routing illustration.	234
FIGURE D-29. Example of a cabling diagram with table.	235
FIGURE D-30. Example of a cable interconnect diagram.	236
FIGURE D-31. Example of a piping diagram.	237
FIGURE D-32. Example of port identification.	238
FIGURE D-33. Example of pattern codes.	239

MIL-STD-3001-1A(AS) w/CHANGE 1

1. SCOPE

1.1 Scope. This part of the standard establishes the technical content and mandatory style and format requirements to develop and assemble complete technical manuals (TMs) for aircraft weapon systems, aeronautical equipment, airborne weapons/equipment, training systems, and support equipment WP TMs. This data can be used to develop TMs in a variety of output forms, including interactive screen presentations and page-based printed and screen displayed portable document format (PDF) TMs. [Appendix A](#) contains the Technical Manual Content Selection Matrixes that can be used to tailor specific content for each type of TM covered by this standard. [Appendix B](#) contains the mandatory style and format requirements needed to produce both paper and digitally displayed page-oriented TMs. [Appendix C](#) provides the requirements for the display of IETMs on any viewer that supports MIL-STD-3001-1. [Appendix D](#) provides guidelines for and examples of the types of graphics used in the development of WP TMs. MIL-STD-3001-2 through MIL-STD-3001-8 contain specific functional technical content requirements for the preparation of all TMs and revisions covering maintenance and operation, at all levels through depot. The eight parts of this standard are listed below:

- a. MIL-STD-3001-1 Preparation of Digital Technical Information for Multi-output Presentation of Technical Manuals
- b. MIL-STD-3001-2 Description, Principles of Operation, and Operation Data
- c. MIL-STD-3001-3 Testing and Troubleshooting Procedures
- d. MIL-STD-3001-4 Maintenance Information with Illustrated Parts Breakdown (IPB)
- e. MIL-STD-3001-5 Aircraft Wiring Information
- f. MIL-STD-3001-6 Structural Repair Information
- g. MIL-STD-3001-7 Periodic Maintenance Requirements
- h. MIL-STD-3001-8 Illustrated Parts Breakdown (IPBs)

2. APPLICABLE DOCUMENTS

2.1 General. The documents listed in this section are specified in sections 3, 4, or 5 of MIL-STD-3001-1 through MIL-STD-3001-8. This section does not include documents cited in other sections of this eight-part standard or recommended for additional information or as examples. While every effort has been made to ensure the completeness of this list, document users are cautioned that they must meet all specified requirements of documents cited in sections 3, 4, or 5 of MIL-STD-3001-1 through MIL-STD-3001-8, whether or not they are listed.

2.2 Government documents

2.2.1 Specifications, standards, and handbooks. The following specifications, standards, and handbooks form a part of this document to the extent specified herein. Unless otherwise specified, the issues of these documents are those cited in the solicitation or contract.

MIL-STD-3001-1A(AS) w/CHANGE 1

FEDERAL STANDARD

FED-STD-313	Material Safety Data, Transportation Data and Disposal Data for Hazardous Materials Furnished to Government Activities
-------------	--

DEPARTMENT OF DEFENSE SPECIFICATIONS

MIL-PRF-28000	Digital Representation for Communication of Product Data: IGES Application Subsets and IGES Application Protocols
MIL-PRF-28002	Raster Graphics Representation in Binary Format, Requirements for
MIL-PRF-28003	Digital Representation for Communication of Illustration Data: CGM Application Profile

DEPARTMENT OF DEFENSE STANDARDS

MIL-STD-1309	Definition of Terms for Testing, Measurement, and Diagnostics
MIL-STD-2073-1	Standard Practice for Military Packaging
MIL-STD-31000	Technical Data Packages

(Copies of these documents are available online at <http://quicksearch.dla.mil>.)

2.2.2 Other Government documents and publications. The following other Government documents and publications form a part of this document to the extent specified herein. Unless otherwise specified, the issues of these documents are those cited in the solicitation or contract.

DEFENSE LOGISTICS INFORMATION SERVICE RESOURCES

H6	Federal Item Name Directory
----	-----------------------------

(The H6 is available at <https://www.dlis.dla.mil/H6/search.aspx> or <http://www.logisticsinformationservice.dla.mil/hseries.asp>.)

H4/H8	Commercial and Government Entity (CAGE) Codes
-------	---

(The H4 and H8 are available on CD-ROM/DVD via subscription from the Defense Logistics Agency (DLA) Logistics Information Service.)

DEPARTMENT OF DEFENSE PUBLICATIONS

DoD DIRECTIVES, INSTRUCTIONS, AND MANUALS

DoDM 5200.01-Volume 1	DoD Information Security Program: Overview, Classification, and Declassification
DoDM 5200.01-Volume 2	DoD Information Security Program: Marking of Classified Information
DoDM 5200.01-Volume 3	DoD Information Security Program: Protection of Classified Information

MIL-STD-3001-1A(AS) w/CHANGE 1

DoDM 5200.01-Volume 4	DoD Information Security Program: Controlled Unclassified Information (CUI)
DoD 5220.22M	National Industrial Security Program Operating Manual
DoDI 5230.24	Distribution Statements on Technical Documents
DoD 6050.05	DoD Hazard Communication Program

DEPARTMENT OF NAVY INSTRUCTION

SECNAV M-5510.36	Department of the Navy (DoN) Information Security Program (ISP) Manual
------------------	--

CHIEF OF NAVAL OPERATIONS INSTRUCTIONS

OPNAVINST 5090.1	Environmental Readiness Program
OPNAVINST 5100.19	Navy Safety and Occupational Health (SOH) Program Manual for Forces Afloat
OPNAVINST 5100.23	Navy Safety and Occupational Health Program Manual

(Copies of these instructions are available online from <http://www.dtic.mil/whs/directives>, <https://doni.daps.dla.mil>, or <http://ihserc.com> [account needed].)

COMMANDER NAVAL AIR FORCES INSTRUCTION

COMNAVAIRFORINST 4790.2	The Naval Aviation Maintenance Program (NAMP)
-------------------------	---

(Copies of this instruction are available at <http://www.navair.navy.mil/logistics/4790/>.)

NAVAL AIR SYSTEMS COMMAND INSTRUCTIONS

NAVAIRINST 4120.11	Policy for Preparation and Standardization of the Naval Air Systems Command Interactive Electronic Technical Manuals (IETMs)
NAVAIRINST 13120.1	Fixed Wing Aircraft Structural Life Limits
NAVAIRINST 13130.1	Rotary Wing Aircraft Structural Life Limits

(Copies of these instructions are available online at <http://www.dtic.mil/whs/directives>, <https://doni.daps.dla.mil>, or <http://ihserc.com> [account needed].)

FEDERAL EXECUTIVE ORDERS

EO 12196	Occupational Safety and Health Programs for Federal Employees
EO 12856	Federal Compliance with Right-to-Know Laws and Pollution Prevention Requirements
EO 13526	Classified National Security Information

(Copies of these documents are available online from the National Archives via the Federal Register at <http://www.archives.gov>.)

MIL-STD-3001-1A(AS) w/CHANGE 1

Joint Publication 1-02 Department of Defense Dictionary of Military and
Associated Terms

(The Joint Publication is available at http://www.dtic.mil/doctrine/new_pubs/jp1_02.pdf.)

DEPARTMENT OF LABOR

29 CFR 1910.1200 Hazard Communication

DEPARTMENT OF TRANSPORTATION

49 CFR Transportation

(Copies of the Code of Federal Regulations (CFRs) are available online at <http://www.ecfr.gov>.)

MARINE CORPS

MCO 1200.17 Military Occupational Specialties Manual (MOS Manual)

(Copies of this document are available online from <http://www.marines.mil/Portals/59/MCO%201200.17E.pdf>.)

NAVAL AIR SYSTEMS COMMAND

NAVAIR 00-25-100	Technical Manual Program
NAVAIR 00-25-300	Naval Air Systems Command Technical Directives System
NAVAIR 00-25-604	NAVAIR Systems Command Fleet Support/Integrated Program Team Acquisition and Sustainment of NAVAIR Technical Manuals
NAVAIR 01-1A-23	Standard Maintenance Practices for Miniature/ Microminiature (2M) Electronic Assembly Repair
NAVAIR 01-1A-505 Series	Installation Practices, Aircraft Electric and Electronic Wiring
NAVAIR 01-1A-509-1	Cleaning and Corrosion Control Volume. I, Corrosion Program and Corrosion Theory
NAVAIR 01-1A-509-2	Cleaning and Corrosion Control Volume. II Aircraft
NAVAIR 01-1A-509-4	Cleaning and Corrosion Control Volume. IV Consumable Materials and Equipment for Aircraft and Avionics
NAVAIR 17-600-117-6-2	Periodic Maintenance Requirements, Helicopter Engine, Aft Transmission Winch and Retainer Sub-Assembly, A02E5808-78

(Copies of these technical manuals are available online at <https://mynatec.navair.navy.mil/> [account needed] or by request to Commanding Officer, Naval Air Technical Data and Engineering Service Center, NAS North Island, Bldg. 90, P.O. Box 357031, San Diego, CA 92135-7031.)

MIL-STD-3001-1A(AS) w/CHANGE 1

NAVAL SEA SYSTEMS COMMAND

NAVSEA OD 30393	Design Principles and Practices for Controlling Hazards of Electro-Magnetic Radiation to Ordnance (HERO Design Guide)
NAVSEA	Standard Drawing 803-5001049 Symbols, Piping System

Copies of these documents are available from the Commander, Naval Sea Systems Command, ATTN: SEA 05B5, 1333 Isaac Hull Avenue, SE, Stop 5160, Washington Navy Yard DC 20376-5160 or by email at CommandStandards@navy.mil.

NAVAL SUPPLY SYSTEMS COMMAND

NAVICP P2300 Series	Data Set
NAVSUP P700-CNP	Common Naval Packaging Data (P700-CNP)
NAVSUPINST 5100.27	Navy Hazardous Material Control Program

(The P2300 series is part of NAVSUP Publication 600. Copies of NAVSUP 600D (for Government personnel) and NAVSUP 600F (for contractors) are available online at <https://tarp.navsisa.navy.mil>. (P700-CNP data is also available online at <https://tarp.navsisa.navy.mil>.) (The NAVSUPINST is available at <http://ihserc.com> [account needed].)

NAVY PERSONNEL COMMAND

NAVPERS 18068	Navy Enlisted Manpower and Personnel Classifications and Occupational Standards
---------------	---

(Copies of this document are available online at <http://www.public.navy.mil/bupers-npc/reference/nec/Pages/default.aspx>.)

OCCUPATIONAL SAFETY AND HEALTH ADMINISTRATION (OSHA)

Public Law 91-596	Occupational Safety and Health Act, dated December 29, 1970 with Executive Order 12196 (Occupational Safety and Health Programs for Federal Employees)
-------------------	--

(Copies of this document are available <https://www.osha.gov/law-regs.html>. The executive order is available at www.archives.gov.)

2.3 Non-Government publications. The following documents form a part of this document to the extent specified herein. Unless otherwise specified, the issues of these documents are those cited in the solicitation or contract.

AMERICAN NATIONAL STANDARDS INSTITUTE (ANSI)

ANSI Y14.2	Line Conventions and Lettering
ANSI/ISO 8879	Information Processing - Text and Office Systems – Standard Generalized Markup Language (SGML)

(Copies of these documents are available online at <http://www.ansi.org>.)

MIL-STD-3001-1A(AS) w/CHANGE 1

AMERICAN SOCIETY OF MECHANICAL ENGINEERS (ASME)

ASME Y14.5	Dimensioning and Tolerancing
ASME Y14.24	Types and Applications of Engineering Drawings
ASME Y14.34	Associated Lists
ASME Y14.35	Revision of Engineering Drawings and Associated Documents
ASME Y14.44	Reference Designations for Electrical and Electronics Parts and Equipment
ASME Y14.100	Engineering Drawing Practices

(Copies of these documents are available online at <http://www.asme.org>.)

AMERICAN SOCIETY FOR TESTING AND MATERIALS (ASTM INTERNATIONAL)

ASTM F856	Standard Practice for Mechanical Symbols, Shipboard—Heating, Ventilation, and Air Conditioning (HVAC)
-----------	---

(Copies of this document are available online at www.astm.org.)

INSTITUTE OF ELECTRICAL AND ELECTRONICS ENGINEERS (IEEE)

IEEE STD 91A/91	Graphic Symbols for Logic Functions
IEEE C95.1	Standard for Safety Levels with Respect to Human Exposure to Radio Frequency Electromagnetic Fields, 3 kHz to 300 GHz
IEEE C95.3	Recommended Practice for Measurements and Computations of Electric, Magnetic, and Electromagnetic Fields with Respect to Human Exposure to Such Fields, 0 Hz to 100 kHz
IEEE STD 260.1	Standard Letter Symbols for Units of Measurement (SI Units, Customary Inch-Pound Units, and Certain other Units)
IEEE 280	Standard Letter Symbols for Quantities Used in Electrical Science and Electrical Engineering
IEEE 315 SUPP	Supplement to Graphic Symbols for Electrical and Electronics Diagrams

(Copies of these documents are available online at <http://www.ieee.org>.)

INTERNATIONAL ORGANIZATION FOR STANDARDIZATION

ISO 1219-1	Fluid Power Systems and Components – Graphical Symbols and Circuit Diagrams – Part 1: Graphical Symbols for Conventional Use and Data-processing Applications
ISO 1219-2	Fluid Power Systems and Components – Graphical Symbols and Circuit Diagrams – Part 2: Circuit Diagrams

(Copies of these documents are available online at www.iso.org.)

MIL-STD-3001-1A(AS) w/CHANGE 1

SOCIETY OF AUTOMOTIVE ENGINEERS (SAE) INTERNATIONAL

SAE AS50881

Wiring Aerospace Vehicle

(Copies of this document are available online at <http://www.sae.org>.)

WORLD WIDE WEB CONSORTIUM (W3C)

REC-XML-20001006

Extensible Markup Language (XML) 1.0 (2nd Edition)(Copies of this document are available at <http://www.w3.org/TR/2000/REC-xml-20001006>.)

2.4 Order of precedence. Unless otherwise noted herein or in the contract, in the event of a conflict between the text of this document and the references cited herein, the text of this document takes precedence. Nothing in this document, however, supersedes applicable laws and regulations unless a specific exemption has been obtained.

3. DEFINITIONS

3.1 Acronyms used in this standard. The acronyms used in this standard are defined as follows:

AAE	Airborne Armament Equipment.
ALSS	Aviation Life Support Systems.
AMCM	Airborne Mine Countermeasure.
AMSC	Acquisition Management Systems Control.
AN	Army/Navy.
ANSI	American National Standards Institute.
APML	Assistant Project Manager, Logistics.
ARDC	Armament Research and Development Center.
ASCII	American Standard Code for Information Interchange.
ASME	American Society of Mechanical Engineers.
ASPA	Aircraft Service Period Adjustment.
ASSIST	Acquisition Streamlining and Standardization Information System.
ASSY	Assembly.
ATE	Automatic Test Equipment.
BCM	Beyond Capability of Maintenance.
BIT	Built-in Test.
BITE	Built-in Test Equipment.
CAC	Critical Alloy Code.
CAGE	Commercial and Government Entity.
CAGEC	Commercial and Government Entity Code.
CALS	Continuous Acquisition and Life-cycle Support.
CCB	Change Control Board.
CCITT	Consultative Committee for International Telegraphy and Telephony.
CD	Compact Disk.

MIL-STD-3001-1A(AS) w/CHANGE 1

CD-ROM	Compact Disk-Read Only Memory.
CER	Complete Engine Repair.
CFR	Code of Federal Regulations.
CGM	Computer Graphics Metafile.
COML	Commercial.
CRT	Cathode Ray Tube.
CSI	Critical Safety Items.
CSP	Critical Safety Process.
DFARS	Defense Federal Acquisition Regulation Supplement.
DIC	Direct Image Copy.
DoD	Department of Defense.
DORT	Daily Operational Readiness Tests.
DTD	Document Type Definition.
ECP	Engineering Change Proposal.
EMP	Electromagnetic Pulses.
EMT	Elapsed Maintenance Time
EO	Executive Order.
ESD	Electrostatic Discharge.
ESDS	Electrostatic Device Sensitive.
FAR	Federal Acquisition Regulations.
FOSI	Formatting Output Specification Instance.
FRC	Fleet Readiness Center
GAPL	Group Assembly Parts List.
GFE	Government Furnished Equipment.
GHz	Gigahertz.
HCI	Hardness Critical Items.
HCP	Hardness Critical Process.
HERO	Hazards of Electromagnetic Radiation to Ordnance.
HMC&M	Hazardous Material Control and Management.
HMIS	Hazardous Material Information System.
HMWS	Hazardous Materials Warning Summary.
HTML	HyperText Markup Language.
IEC	International Electrotechnical Commission.
IEEE	Institute of Electrical and Electronics Engineers.
IETM	Interactive Electronic Technical Manual.
IGES	Initial Graphics Exchange Specification.
ILS	Integrated Logistics Support.
IMM	Intermediate Maintenance Manual.
IMRL	Individual Material Readiness List.
INSTL	Installation.
IPB	Illustrated Parts Breakdown.

MIL-STD-3001-1A(AS) w/CHANGE 1

IPR	In-Process Review.
IRAC	Interim Rapid Action Change.
ISO	International Organization for Standardization.
JAN	Joint Army-Navy.
JTC	Joint Technical Committee.
kHz	Kilohertz.
LEM	Logistics Element Manager.
LMI	Logistics Management Information.
LORA	Level of Repair Analysis.
LOX	Liquid Oxygen.
LSA	Logistics Support Analysis.
LSAR	Logistics Support Analysis Record.
MAG	Magnetic Control Item.
MCO	Marine Corps Order.
MLG	Main Landing Gear.
MOS	Military Occupational Specialty.
MP	Maintenance Plan.
MRC	Maintenance Requirement Card.
MS	Military Standard.
MSDS	Material Safety Data Sheet.
NAS	Naval Air Station or National Aerospace Standards.
NATEC	Naval Air Technical Data and Engineering Service Command.
NATO	North Atlantic Treaty Organization.
NATSF	Naval Air Technical Services Facility.
NAVAIR	Naval Air Systems Command.
NAVAIRINST	Naval Air Systems Command Instruction.
NAVICP	Naval Aviation Inventory Control Point (now NAVSUP WSS).
NAVOSH	Navy Occupational Safety and Health.
NAVPERS	Naval Personnel Command.
NAVSEA	Naval Sea Systems Command.
NAVSUP	Naval Supply Systems Command.
NAVSUP WSS	Naval Supply Systems Command Weapon Systems Support.
NAVSUPINST	Naval Supply Systems Command Instruction.
NDI	Nondestructive Inspection.
NHA	Next Higher Assembly.
NIIN	National Item Identification Number.
NSA	National Security Agency.
NSIV	NAVAIR Standard IETM Viewer.
NSN	National Stock Number.
OCI	Observable Critical Items.
OCP	Observable Critical Process.

MIL-STD-3001-1A(AS) w/CHANGE 1

OD	Ordnance Directive.
ODS	Ozone Depleting Substances.
OJCS	Organization of the Joint Chiefs of Staff.
OLSP	Operational Logistics Support Plan.
OMM	Organization Maintenance Manual.
OPNAVINST	Chief of Naval Operations Instruction
OS	Output Specification.
OSD	Office of the Secretary of Defense.
OSHA	Occupational Safety and Health Act.
P/N	Part Number.
PAT	Powered Aerial Target.
PEMA	Portable Electronic Maintenance Aid.
PMIC	Precious Metal Indicator Code.
PMRC	Periodic Maintenance Requirements Card.
PMRM	Periodic Maintenance Requirements Manual.
PSE	Peculiar Support Equipment.
PST	Powered Surface Target.
QA	Quality Assurance.
QEC	Quick Engine Change.
QECA	Quick Engine Change Assembly.
QECK	Quick Engine Change Kit.
QECS	Quick Engine Change Stand.
RAC	Rapid Action Change.
RAM	Reliability, Availability, Maintainability.
RAMEC	Rapid Action Minor Engineering Change.
RCN	Report Control Number.
RTG	Rating.
SCC	Sequence Control Chart.
SE	Support Equipment.
SECNAV	Secretary of the Navy.
SGML	Standard Generalized Markup Language.
SM&R	Source, Maintenance and Recoverability.
SRA	Shop Replaceable Assembly.
SS	Special Stores.
STD	Standard.
STOL	Short Take Off and Landing.
TD	Technical Directive.
TM	Technical Manual.
TMCR	Technical Manual Contract Requirements.
TMINS	Standard Technical Manual Identification System.
TMQA	Technical Manual Quality Assurance.

MIL-STD-3001-1A(AS) w/CHANGE 1

TMSS	Technical Manuals Specifications and Standards.
TP	Technical Publication or Test Point.
TPDR	Technical Publication Deficiency Report.
TREE	Transient Radiation Effects on Electronics.
TS	Training System
TUE	Trainer Unique Equipment
UAV	Unmanned Aerial Vehicle.
USAF	United States Air Force.
VTOL	Vertical Take Off and Landing.
WP	Work Package.
WRA	Weapons Replaceable Assembly.
WUC	Work Unit Code.
XML	Extensible Markup Language.

3.2 Definitions of selected terms.

3.2.1 Adjust. To maintain or regulate within prescribed limits, by bringing into proper position, or by setting the operating characteristics to specified parameters.

3.2.2 Alert. An alert is any message, communication, notice, or output which requires acknowledgment from the user of the IETM.

3.2.3 Align. To adjust specified variable elements of an item to bring about optimum or desired performance.

3.2.4 American National Standards Institute (ANSI). A private sector organization which plans, develops, establishes or coordinates standards, specifications, handbooks or related documents.

3.2.5 Assembly. Two or more parts or subassemblies joined together to perform a specific function and capable of disassembly (e.g., brake assembly, fan assembly, audio frequency amplifier).

NOTE

The distinction between an assembly and subassembly is determined by the individual application. An assembly in one instance may be a subassembly in another where it forms a portion of an assembly.

3.2.6 Block diagram. A modified schematic diagram in which each group of maintenance-significant components that together perform one or more functions is represented by a single symbol or block. The block or symbol representing the group of components shows simplified relevant input and output signals pertinent to the subject diagram.

3.2.7 Built-in test equipment (BITE). Any identifiable device that is part of the supported end item and is used for testing that supported end item.

3.2.8 Calibrate. To determine and cause corrections or adjustments to be made to instruments or test, measuring, and diagnostic equipment used in precision measurement. Consists of

MIL-STD-3001-1A(AS) w/CHANGE 1

comparisons of two instruments, one of which is a certified standard of known accuracy, to detect and adjust any discrepancy in the accuracy of the instrument being compared.

3.2.9 Callout. Anything placed on an illustration to aid in identifying the objects being illustrated, such as index numbers, nomenclature, leader lines, and arrows.

3.2.10 CALS raster. Compressed scanned raster images (CCITT, Group 4) in accordance with MIL-PRF-28002.

3.2.11 Caution. A statement or some other notification about an operating or maintenance procedure, practice, or condition that, if not strictly observed, could result in damage to, or destruction of, equipment or loss of mission effectiveness.

3.2.12 Client area. The area between the menu bar and the footer bar of the window in an IETM.

3.2.13 Commercial and Government Entity (CAGE) Code. A five-character code assigned to commercial activities that manufacture or supply items used by the Federal Government and to Government activities that control design or are responsible for the development of certain specifications, standards, or drawings which control the design of Government items. CAGE codes can be accessed at www.SAM.gov.

3.2.14 Comprehensibility. The completeness with which a user in the target audience understands the information in the TM.

3.2.15 Computer Graphics Metafile (CGM). A standard digital form for vector graphics preparation as defined by MIL-PRF-28003.

3.2.16 Continuous Acquisition and Life-cycle Support (CAL S). A DoD initiative to transition from paper-intensive, non-integrated weapon systems design, manufacturing, and support processes to a highly automated and integrated mode of operation. This transition will be facilitated by acquiring, managing, and using technical data in standardized digital form.

3.2.17 Continuous tone photographs or drawings. Continuous tone photographs or drawings have a continuous gradation of tonal values ranging from light (white) to dark (black), including gray. These tonal values are not created by lines or dots.

3.2.18 Copy freeze date. A date set by the contracting activity after which no additions, deletions, or changes will be accepted to the publication material.

3.2.19 Data pane. Sub areas or a division of a frame on the Portable Electronic Maintenance Aid (PEMA).

3.2.20 Department of Defense (DoD). The Office of the Secretary of Defense (OSD) (including all boards and councils), the Military Departments (Army, Navy, and Air Force), the Organization of the Joint Chiefs of Staff (OJCS), the Unified and Specified Commands, the National Security Agency (NSA), and the Defense Agencies.

3.2.21 Deleted definition.

MIL-STD-3001-1A(AS) w/CHANGE 1

3.2.22 Depot-level maintenance. Maintenance done on material requiring major rework or a complete rebuild of parts, assemblies, subassemblies, and end items, including manufacture, modification, testing, and reclamation of parts as required. D-level maintenance serves to support lower levels of maintenance by providing technical assistance and performing maintenance beyond the responsibility of O-level and I-level maintenance. D-level maintenance provides stocks of serviceable equipment by using more extensive facilities for repair than are available in lower level maintenance activities.

3.2.23 Digital graphics forms. A standard graphics form acceptable for graphics preparation in accordance with graphic standards listed in MIL-STD-3001-1. These forms include CGM, CALS raster, and Initial Graphics Exchange Specification (IGES).

3.2.24 Direct image copy (DIC). One-on-one reproducible without paste-overs or mortises, suitable for use on a copier or making direct image masters. Quality should be such that if a negative were to be prepared, only the imperfection due to the quality of photolithographic film would require touch up before making the offset plates.

3.2.25 Disassemble. The step-by-step taking apart (or breakdown) of an assembly or subassembly to the lowest level of its parts identification as maintenance-significant (i.e., assigned an SM&R code for the category of maintenance under consideration).

3.2.26 Document Type Definition (DTD). The definition of the markup rules for a given class of documents. A DTD or reference to one should be contained in any XML conforming document.

3.2.27 Effectivity. The act or process of identifying weapon systems or end-items and their hardware and software system and subsystems by their associated usable on code (UOC), serial number, model number, tail numbers, BUNO number, part number (P/N), or software version. Effectivity is included to signify that certain configurations or modifications apply to a given weapon system/equipment.

3.2.28 Electromagnetic Pulse (EMP). A burst of electromagnetic radiation that results from an explosion (especially a nuclear explosion) and/or a suddenly fluctuating magnetic field. The resulting electric and magnetic fields may couple with electrical/electronic systems to produce damaging current and voltage surges.

3.2.29 Electrostatic Discharge (ESD). Static electricity: A transfer of electrostatic charge between objects of different potentials caused by direct contact or induced by an electrostatic field. Devices such as integrated circuits and discrete devices (e.g., resistors, transistors, and other semiconductor devices) are susceptible to damage from electrostatic discharge.

3.2.30 Expendable items. Items, other than repair parts, that are consumed in use (e.g., paint, lubricants, wiping rags, tape, cleaning compounds, sandpaper).

3.2.31 Extensible Markup Language (XML). A subset of SGML as specified in REC-XML-20001006. It enables generic SGML to be served, received, and processed on the internet in the way that is now possible with HTML. XML has been designed for ease of implementation and for interoperability with SGML.

MIL-STD-3001-1A(AS) w/CHANGE 1

3.2.32 Extensible Markup Language (XML) declaration. Defines which characters are used in a document instance, in which syntax the DTD is written, which XML features are used, etc.

3.2.33 Footer. One or more lines of text that appear at the bottom of each page (also called foot and running foot).

3.2.34 Formatting Output Specification Instance (FOSI). The FOSI interprets the style and formatting requirements of the Output Specification (OS). The FOSI can include font, leading, hyphenation characteristics, etc.

3.2.35 Frame. An area of the display screen with visible boundaries which displays the information in the IETM.

3.2.36 Frame-based interactive electronic technical manual (IETM). An IETM which has been designed to be displayed frame by frame.

3.2.37 Functional diagram. A type of illustration in which symbols are connected by lines to show relationships among the symbols. The symbols may be rectangles or other shapes, standard electronic symbols representing components or functions, or pictorials representing equipment or components. Where appropriate, voltage readings are shown. The lines may represent procedures or processes, such as signal or logic flow, and physical items, such as wires. A functional diagram includes schematics, wiring and piping diagrams, logic diagrams, flow charts, and block diagrams.

3.2.38 Graphic(s). Any type of presentation or representation which gives a clear visual impression.

3.2.39 Halftones. Halftones are the tonal values of gray and black created by lines or dots. It is a conversion of a continuous tone print.

3.2.40 Hardness Critical Item (HCI). A support item that provides the equipment with special protection from electromagnetic pulse (EMP) damage during a nuclear attack.

3.2.41 Hardness Critical Process (HCP). A process affecting a mission critical item which could degrade system survivability in a nuclear, biological, or chemical hostile environment if hardness were not considered. Nuclear HCPs are processes, finishes, specifications, manufacturing techniques, and/or procedures which are hardness critical, and which, if changed, could degrade nuclear hardness.

3.2.42 Header. One or more lines of standard text that appear at the top of each page (also called heads and running heads).

3.2.43 Horizontal (landscape) TM format. The positioning of TM content so that page horizontal (width) dimensions are greater than vertical (height) dimensions.

3.2.44 Hotspot. An area of the display which acts as a hidden button. Touching the hotspot selects designated information for display.

3.2.45 Icon. Pictorial representation (e.g., a visual image to give immediate recognition of a hazard, or to provide essential information).

MIL-STD-3001-1A(AS) w/CHANGE 1

3.2.46 Illustration. A general term meaning graphic presentations of all types. Illustrations include pictorials, functional diagrams, and line graphs. This term is used instead of such terms as figure, graphic, drawing, diagram, and artwork.

3.2.47 Index numbers and letters. A number or letter (on a figure or an illustration) usually attached to a line or an arrow which points to an object on the illustration. This number or letter corresponds to the same number or letter in a legend or text which defines or identifies the object in the illustration.

3.2.48 Initial Graphics Exchange Specification (IGES). A standard digital form for vector graphics preparation as defined by MIL-PRF-28000.

3.2.49 Inspect. To determine the serviceability of an item by comparing its physical, mechanical, and/or electrical characteristics with established standards through examination (e.g., by sight, sound, or feel).

3.2.50 Institute of Electrical and Electronics Engineers (IEEE). Membership organization that includes engineers, scientists and students in electronics and allied fields. Founded in 1963, it has over 300,000 members and is involved with setting standards for computers and communications.

3.2.51 Interactive electronic technical manual (IETM). An IETM is a TM, prepared (authored) by a contractor and delivered to the Government or prepared by a Government activity, in digital form on a suitable medium, by means of an automated authoring system; designed for electronic screen presentation to an end user; and may possess the following three characteristics: (1) The format and style of the presented information are optimized for screen presentation to assure maximum comprehension; that is, the information presented is frame-oriented or hyperlinked page-oriented; (2) The elements of technical information constituting the IETM are so interrelated that a user's access to the information he/she requires is facilitated to the greatest extent possible, and is achievable by a variety of paths; (3) The computer-controlled presentation of the IETM can function interactively (as a result of user request and information input) in providing procedural guidance, navigational directions, and supplemental information; and also in providing assistance in carrying out logistic support functions supplemental to maintenance.

3.2.52 Intermediate-level maintenance. Maintenance which is the responsibility of, and performed by, designated maintenance activities for direct support of using organizations. Its phases normally consist of calibration, repair or replacement of damaged or unserviceable parts, components, or assemblies; the emergency manufacture of nonavailable parts; and the provision of technical assistance to using organizations.

3.2.53 International Organization for Standardization (ISO). An organization that sets international standards, founded in 1946 and headquartered in Geneva. It deals with all fields except electrical and electronics, which are governed by the older International Electrotechnical Commission (IEC), also in Geneva. With regard to information processing, ISO and IEC created JTC1, the Joint Technical Committee for information technology.

3.2.54 Landscape mode. To print an image sideways on the page so that the longest edge of the form corresponds to the horizontal axis.

MIL-STD-3001-1A(AS) w/CHANGE 1

- 3.2.55 Legend. A tabular listing and explanation of the numbers or symbols on a figure or an illustration.
- 3.2.56 Logic text. Text that is composed of procedures and actions branching to a series of questions, that results in a "yes" or "no" answer leading to determination and resolution of the problem.
- 3.2.57 Logic tree. A diagram comprised of a branching series of questions, resulting in a "yes" or "no" answer, leading to determination and resolution of the problem.
- 3.2.58 Logistics Management Information (LMI). The selective application of scientific and engineering efforts undertaken during the acquisition process, as part of the systems engineering process, to assist in acquiring the required support; and providing the required support during the operational phase at minimum cost. Replaces Logistics Support Analysis (LSA).
- 3.2.59 Logistics Support Analysis (LSA). The selective application of scientific and engineering efforts undertaken during the acquisition process, as part of the systems engineering process, to assist in acquiring the required support; and providing the required support during the operational phase at minimum cost.
- 3.2.60 Lubricant. Any solid, fluid, or semifluid material that performs a lubricating or related specialty function. Such materials include lubricating oils, greases, hydraulic fluids, damping fluids, dielectric coolants, anti-seize compounds, corrosion preventatives, and bonded or unbonded solid films.
- 3.2.61 Maintenance level. Maintenance tasks divided into the number of levels required so common standards can be applied to the many and varied aircraft maintenance activities of the military establishment. They are increments of which all maintenance activities are composed. Joint Publication 1-02 defines the three levels as depot, intermediate, and organizational.
- 3.2.62 Maintenance step. A single maintenance action, such as setting a switch to the OFF position. Usually, a step has one action, but in certain cases, there may be a series of identical actions, such as removing seven bolts.
- 3.2.63 Marginal copy. Copy (generally headers and footers) placed outside that portion of the page used for either text, full page tabular data, or full page illustrations, but within the printing area dimensions of the page.
- 3.2.64 Menu bar. A region located directly under the title bar that displays selectable menu titles.
- 3.2.65 National item identification number (NIIN). The last nine digits of the National/NATO stock number. The first two digits of the NIIN identify the country assigning the number and the remaining seven digits are a serially assigned number.
- 3.2.66 National stock number (NSN). A 13-digit number assigned to a repair part to be used for requisitioning purposes.
- 3.2.67 Next higher assembly (NHA). An assembly or subassembly of which subject component(s) or subassembly are a subpart.

MIL-STD-3001-1A(AS) w/CHANGE 1

3.2.68 Nomenclature. The approved name or alphanumeric identifier assigned to an item, equipment, or component in agreement with an organized designation system.

3.2.69 Note. A statement or some other notification that adds, emphasizes, or clarifies essential information of special importance or interest.

3.2.70 Novice user. An IETM user who possesses only a general understanding of, and has had only limited training on, the system being operated, fault-isolated, or maintained.

3.2.71 Organizational-level maintenance. Maintenance which is the responsibility of, and performed by, a using organization on its assigned equipment. Its phases normally consist of inspecting, servicing, lubricating, adjusting, and replacing parts, minor assemblies, and subassemblies.

3.2.72 Overhaul. That maintenance effort (service/action) prescribed to restore an item to a completely serviceable/operational condition as required by maintenance standards in appropriate technical publications.

3.2.73 Ozone Depleting Substances (ODS). Compounds that contribute to the depletion of the earth's stratospheric ozone layer beyond natural cycles. ODS include chlorofluorocarbons (CFC), hydrochlorofluorocarbon (HCFC), halons, methyl bromide, carbon tetrachloride, and methyl chloroform.

3.2.74 Part number (P/N). A primary number used to identify an item used by the manufacturer (individual, company, firm, corporation, or Government activity) that controls the design, characteristics, and production of the item by means of engineering drawings, specifications, and inspection requirements.

3.2.75 Pictorial. A type of illustration showing the physical appearance of equipment or component parts. This term is used instead of such general terms as illustration, drawing, and diagram.

3.2.76 Portable electronic maintenance aid (PEMA). An electronic device on which display images can be represented; most often a CRT or a liquid-crystal device.

3.2.77 Pre-screening. A process in which a clear material with a dot pattern or crossing opaque lines is used through which an image is photographed in making a halftone.

3.2.78 Preventive maintenance (scheduled maintenance). The performance of scheduled inspections and maintenance functions necessary to keep the equipment in serviceable condition and ready for its primary mission.

3.2.79 Readability. Text comprehensibility measured by such variables as number of syllables, words, and sentences.

3.2.80 Reference designator. Letters or numbers, or both, used to identify and locate discreet units, portions thereof, and basic parts of a specific equipment, assembly, or subassembly.

3.2.81 Reliability, availability, maintainability (RAM). DoD guidance that addresses the essential elements of mission capability. Requirements are imposed on materiel systems to

MIL-STD-3001-1A(AS) w/CHANGE 1

ensure that they are operationally ready for use when needed, will successfully perform assigned functions, and can be economically operated and maintained within the scope of logistic concepts and policies.

3.2.82 Remove/install. To remove and install the same item when required to perform service or other maintenance functions. Install may be the act of emplacing, seating, or fixing into position a spare, repair part, or module (component or assembly) in a manner to allow the proper functioning of an equipment or system.

3.2.83 Repair. The application of maintenance services (inspect, test, service, adjust, align, calibrate, and/or replace), including fault location/troubleshooting, removal/installation, and disassembly/assembly procedures, and maintenance actions to identify troubles and restore serviceability to an item by correcting specific damage, fault, malfunction, or failure in a part, subassembly, module (component or assembly), end item, or system. Repair is authorized by the LSA/LMI and the assigned maintenance level is shown as the fourth position code of the SM&R code.

3.2.84 Repair part. Material capable of separate supply and replacement that is required for the maintenance, overhaul, or the repair of an end article, for example, airframe, accessories, instruments, engine, propeller, electrical, electronics, photographic, armament, and training equipment, including the repair parts of SE. This definition does not include the SE end items.

3.2.85 Replace. To remove an unserviceable part and install a serviceable counterpart in its place. Replace is authorized by the LSA/LMI and the assigned maintenance level is shown as the third position code of the SM&R code.

3.2.86 Requiring activity. The DoD component, activity, or organization of a using military service, or that organization delegated by a using service, that is responsible for the selection and determination of requirements for TMs.

3.2.87 Revision. A revision comprised corrected, updated or additional pages or WPs to the current edition of a manual. It consists of replacement WPs that contain new or updated technical information, or improves, clarifies, or corrects existing information in the current edition of the manual.

3.2.88 Scheduled maintenance (preventive maintenance). The performance of scheduled inspections and maintenance functions necessary to keep the equipment in serviceable condition and ready for its primary mission.

3.2.89 Schematic diagram. A graphic representation showing the interrelationship of each component or group of components in the equipment. The essential characteristic of these diagrams is that every maintenance-significant functional component is separately represented. Also, where appropriate, voltage readings can be shown.

3.2.90 Scrollable. The ability to move a text or graphics display up and down, or left and right, or both.

MIL-STD-3001-1A(AS) w/CHANGE 1

- 3.2.91 Sentence. A group of words conveying a complete thought and terminated by a semicolon, period, exclamation mark, or question mark. Headers, captions, and paragraph titles are not considered sentences.
- 3.2.92 Service. Operations required periodically to keep an item operating, i.e., to clean (includes decontaminate, when required), to preserve, to drain, to paint, or to replenish fuel, lubricants, chemical fluids, or gases.
- 3.2.93 Shop replaceable assembly (SRA). A generic term which includes all the packages within a weapons replaceable assembly (WRA) including chassis and wiring as a unit. (Sub-level mechanization or modular subdivisions within an SRA may occur.) Conversely, a WRA is composed of SRAs.
- 3.2.94 Source, maintenance, and recoverability (SM&R) code. A collective code assigned to items during the provisioning, source coding, or selection process to convey specific information to maintenance and supply personnel. The first two positions of the SM&R code determine how to get an item. The third position represents who can install, replace, or use the item. The fourth position dictates who can do complete repair on the item. The fifth position represents who determines disposition action on unserviceable items.
- 3.2.95 Spare part. Those support items that are an integral part of the end item or weapons system that are coded as repairable (i.e., repairable items).
- 3.2.96 Special tools. Those tools that have single or peculiar application to a specific end item/system.
- 3.2.97 Standard Generalized Markup Language (SGML). A language for document representation that formalizes markup and frees it of system and processing dependencies.
- 3.2.98 "Sticky". In reference to electronic tables, "sticky" infers that the title and column heads must be continually displayed throughout the scrolling process of the entire table.
- 3.2.99 Subassembly. Two or more parts that form a portion of an assembly or a component replaceable as a whole, but having a part or parts that is/are individually replaceable.
- 3.2.100 Task dialog. A pop-up display window by which the computer solicits user input such as a selection of choices.
- 3.2.101 Technical Manual Quality Assurance (TMQA) program. A systematic, coordinated effort to establish a high level of confidence that the TM product offered conforms to established, contractually defined technical requirements. A QA program includes efforts by the contracting activity and requiring activity, including, but not limited to, In-Process Reviews (IPRs), validation, and verification.
- 3.2.102 Technical manuals (TMs). Documents that contain instructions for the installation, operation, maintenance, and support of weapon systems, weapon system components, and support equipment. TM information may be presented, according to prior agreement between the contractor and the Government, in any form or characteristic, including hard printed copy, audio and visual displays, disks, other electronic devices, or other media. They normally include

MIL-STD-3001-1A(AS) w/CHANGE 1

operational and maintenance instructions, parts lists, and related technical information or procedures exclusive of administrative procedures.

3.2.103 Test. To verify serviceability by measuring the mechanical, pneumatic, hydraulic, electrical, or electronic characteristics of an item and comparing those characteristics with prescribed standards.

3.2.104 Text. The written parts of the technical sections excluding labels, legends, and callouts in illustrations.

3.2.105 Title bar. A region located directly above the menu bar that displays the title of the information on a PEMA.

3.2.106 Top-down breakdown. The pyramidal breakdown of an end item, with the top item being the complete end item. The process of breakdown is established from the engineering drawing structure in an NHA progression until the lowest repairable in each family tree group is identified. All nonrepairables can be identified in like manner to establish their NHA relationships.

3.2.107 Transient Radiation Effects on Electronics (TREE). Those effects occurring in electronic systems and associated circuitry as a result of transient radiation from a nuclear weapon detonation. The effects may be transient, semi-permanent, or permanent.

3.2.108 Update. Updates are changes to the initial version of the IETM or to the latest complete revision of an IETM. Updates are issued incrementally as necessary, or as required by the contract.

3.2.109 User. A person using the TM.

3.2.110 Validation. The process by which the contractor tests a TM for technical accuracy and adequacy, comprehensibility, and usability.

3.2.111 Verification. The final QA iteration by the Government for acceptance of the TM during which a TM is tested to determine its adequacy and operational suitability for operation and maintenance of equipment or systems using target audience personnel.

3.2.112 Vertical TM format. The positioning of TM content so that page horizontal (width) dimensions are less than vertical (height) dimensions.

3.2.113 Volume. A separately bound subdivision of a publication.

3.2.114 Warning. A statement or some other notification about an operating or maintenance procedure, practice, or condition that, if not strictly observed, could result in long term health hazard, injury to, or death of personnel performing the task prescribed in the TM.

3.2.115 Weapons replaceable assembly (WRA). A generic term which includes all the replaceable packages of an avionic equipment, pod, or system as installed in an aircraft weapon system with the exception of cables, mounts, and fuse boxes or circuit breakers.

MIL-STD-3001-1A(AS) w/CHANGE 1

3.2.116 Wiring diagram. A diagram illustrating signal flow or wiring connections. Where appropriate, voltage readings can be shown.

3.2.117 Word. Any string of characters (including letters, numbers, symbols, and groups of letters) separated from other strings by one or more spaces. Hyphenated words and contractions count as one word. For example, each of the following counts as one word: couldn't; GFE; i.e.; 32,008; 19-inch; +25°F; left-hand. Thus a sentence like "The left-hand MLG door shouldn't open more than 25°." consists of 9 words.

3.2.118 Work packages (WPs). The presentation of information functionally divided into individual task packages in the logical order of work sequence. These WPs should be stand-alone general information, descriptive, theory, operating, maintenance, troubleshooting, parts, and supporting information units containing all information required for directing task performance.

3.2.119 XML document instance. The document instance is the part of an XML document which contains the marked up textual data.

4. GENERAL REQUIREMENTS

4.1 General. The types of TMs that can be developed using the requirements provided in this standard are provided in subsequent paragraphs. General requirements for the preparation of these TMs in a digital format using Extensible Markup Language (XML) are also provided.

4.2 Technical manual classifications. The NAVAIR WP TMs covered by this standard are classified under the assigned maintenance level(s) described in [4.2.1](#) through [4.2.3](#).

4.2.1 Organizational level. WP organizational level manuals may be either a single manual or a series of manuals covering organizational level operations and maintenance and its associated illustrated parts breakdown (IPB) data. Organizational level information shall normally be defined as "on" aircraft or equipment tasks arranged on a systems concept. "Off" aircraft organizational level tasks include component and support equipment repair, manufacturing, and assembly.

4.2.2 Intermediate and depot levels. WP intermediate and depot level manuals shall be prepared as either individual maintenance level coverage, or combined maintenance level coverage manuals and associated IPB data, based on their application and the approved maintenance plan (MP), logistics support analysis (LSA) or logistics management information (LMI). The documents will normally cover "off" aircraft or "off" equipment tasks arranged by weapons replaceable assembly (WRA) and shop replaceable assembly (SRA). That is, component or assembly maintenance shall be covered instead of the system concept used at the organizational level.

4.2.3 Combined maintenance levels. WP manuals may consist of any combination of level coverage and associated IPB data, predicated on the approved MP or the LSA/LMI, facility requirements, support equipment required, and the volume of information to be presented. Combined maintenance level manuals are most practical when maintenance requirements at each level are fairly consistent, the same support equipment is applied, the same facility requirements are used, and when the overall data volume permits. Organizational level normally shall not be combined with intermediate or depot level data.

MIL-STD-3001-1A(AS) w/CHANGE 1

4.3 Types of technical manuals. TM content selection matrixes provided in Technical Manual Content Selection Matrixes, Appendix A, list the specific technical content requirements and applicable WPs for each type of TM, including multilevel TMs, covered by this standard. Each type of TM shall contain, in detail, the maintenance coverage prescribed for the applicable maintenance level(s) based on the maintenance concept in accordance with the LSA or LMI, the Level of Repair Analysis (LORA), or an approved MP. The following types of WP manuals are covered by the requirements of this standard:

a. Aircraft systems and equipment maintenance instruction manuals:

General aircraft information manual
 Plane captain's manual
 Line maintenance manual
 Principles of operation manual
 Functional flow diagram manual
 Testing and troubleshooting manual
 Fault reporting manual
 Fault isolation manual
 Integrated weapon systems testing and troubleshooting manual
 Maintenance instructions with IPB manual
 Structural repair manual
 Aircraft wiring diagram manual
 Aircraft wire bundle manual
 Aircraft wire connector repair manual
 Power plant build-up manual
 Periodic maintenance requirements card sets
 Illustrated parts breakdown manual.

b. Aeronautical equipment, airborne weapons/equipment, training systems, and support equipment operation and maintenance manuals:

Operation instructions manuals
 Operation and maintenance instructions with IPB manuals
 Maintenance instructions with IPB manuals.

c. Engine intermediate and depot maintenance manuals.

4.4 Maintenance level applicability. Requirements contained in this standard are applicable to all types and maintenance levels of TMs unless specifically noted in bold and in parentheses (e.g., **(Support Equipment Manuals only)**, **(Depot Level only)**, etc.)

4.5 Selective application and tailoring. This standard contains some requirements that may not be applicable to the preparation of all TMs. Selective application and tailoring of requirements contained in MIL-STD-3001-1 through MIL-STD-3001-8 shall be accomplished through the use of the Technical Manual Content Selection Matrixes contained in MIL-STD-3001-1,

MIL-STD-3001-1A(AS) w/CHANGE 1

[Appendix A](#). The applicability of some requirements is also designated by one of the following statements: unless specified otherwise by the requiring activity or as/when specified by the requiring activity.

4.6 Style and format. The technical content requirements contained in MIL-STD-3001-2 through MIL-STD-3001-8 have traditionally been used to produce and distribute TMs to the end user in page-oriented paper form. This data can now be printed on paper and also presented electronically in various formats; therefore, Parts 2 through 8 do not contain format direction (in the sense of arrangement of text and graphics on a page or screen display). For style and format requirements for the output of printed paper and PDF screen displayed TMs, refer to [Appendix B](#). [Appendix C](#) provides the requirements for the display of IETMs on any viewer that supports MIL-STD-3001-1. [Appendix D](#) provides guidance and examples for TM graphics.

4.7 Preparation of digital data for electronic delivery. TM information prepared in a WP structure and delivered digitally in accordance with this standard shall be XML-tagged using modular Document Type Definitions (DTDs). The DTDs are listed below and are available in digital format and can be obtained as instructed in [4.10](#):

- a. TM assembly DTD.
- b. Description, principles of operation, and operation data DTD.
- c. Testing and troubleshooting procedures DTD.
- d. Maintenance information with IPB DTD.
- e. Aircraft wiring information DTD.
- f. Structural repair information DTD.
- g. Periodic maintenance requirements DTD.
- h. Illustrated parts breakdown requirements DTD.

4.8 Development of an XML source file. An XML-tagged source file is composed of the applicable WP technical content in XML-coded ASCII, marked up (tagged) in accordance with the applicable modular DTD. In order to tag WP text appropriately, the author inserting the tags should be familiar with the DTD, or should provide the text file to a person who is experienced with the DTD and who understands the type of documentation being written, especially when content tags are used. For assistance on tagging refer to the MIL-STD-3001-1 XML Authoring and Tagging Guidelines. These guidelines are available when the NAVAIR Standard IETM Viewer is downloaded from the NATEC website at <https://mynatec.navair.navy.mil/>.

4.9 Use of the modular DTDs. The modular DTDs referenced in this standard interpret the technical content and structure for the functional requirements contained in this standard and are mandatory for use.

4.10 Obtaining the modular DTDs. The DTDs, and associated tag and attribute descriptions, which are XML constructs, may be obtained from the requiring activity.

MIL-STD-3001-1A(AS) w/CHANGE 1

4.11 Standard tables and lists. Standard tables and lists are noted throughout the text of MIL-STD-3001-1 through MIL-STD-3001-8 in bold and in parentheses (e.g., **(standard table)**, **(standard list)**). The structure and titles of the column headings for these standard tables and lists shall have no deviations.

4.12 Conflict between standards. When conflict exists between the referenced standards and the technical content requirements described herein, this standard shall take precedence. When conflict exists between the contract and this standard, the contract shall take precedence. If additional clarification or interpretation is required, contact the NAVAIR 6.8.5 Technical Manual National Competency Lead.

4.13 Figures contained in this standard. The examples within this standard show the style and format requirements and subject matter contained in various types of WPs. In an attempt to minimize the size of this standard, most of the technical content provided in the examples is in abbreviated form, and some figures and paragraphs referenced in the text of the example WPs have purposely been omitted. The font size, leading and vertical spacing of the text for the examples have been intentionally compressed to allow the data to fit within the boxed image area of the page.

4.14 Copyrights, proprietary names, and advertising.

4.14.1 Copyright/copyright credit line. TMs shall not contain copyrighted material except as specified in the Federal Acquisition Regulations (FAR) and Defense Federal Acquisition Regulation Supplement (DFARS). When copyrighted material is included in a TM, the developer must obtain prior written permission from the copyright owner or authorized agent for its use. The written permission must contain a statement declaring whether or not a copyright credit line is required.

4.14.2 Proprietary names. Do not use trade names, copyrighted names, or other proprietary names applying exclusively to the product of one company unless the items cannot be adequately described because of the technical involvement, construction, or composition. In such instances, list one, and, if possible, several commercial products, followed by the words "or equal." The same applies to manufacturers' part numbers or drawing numbers for minor parts where it is impractical to specify the exact requirements. If possible, define the particular characteristics required for the "or equal" products.

4.14.3 Advertising. Publication material shall not contain advertising matter.

5. DETAILED REQUIREMENTS

5.1 Development of technical information. The preparing activity must apply the requirements of aircraft, system, or equipment engineering design to the development of technical content information. Once developed, this data can be used to create NAVAIR TMs that can be arranged and formatted for screen display presentation or to produce page-oriented paper TMs and PDF screen displayed TMs. The data shall be organized by functional elements in a logical descriptive, operational, and maintenance task sequence. Technical information shall be derived and fully consistent with the maintenance concepts of the baseline documents described below, and in accordance with the technical content requirements contained in MIL-STD-3001-2 through -8.

MIL-STD-3001-1A(AS) w/CHANGE 1

a. Logistics Support Analysis (LSA) or Logistics Management Information (LMI). The technical data shall be developed in accordance with the LSA/LMI requirements and Department of Defense (DoD) requirements for Logistic Support Analysis Record (LSAR).

b. Approved maintenance plan (MP). The plan for maintenance is a critical requirement for completing in-depth task development. The prime source of maintenance planning information is the NAVAIR Assistant Program Manager, Logistics (APML). The APML is tasked by the Acquisition Program Manager (PM) for the coordination and preparation of maintenance planning information with the cooperation of the various Logistics Element Managers (LEMs). The level of effort performed depends on system complexity, magnitude, and projected cost.

(1) Small programs. Small projects do not require the elaborate planning necessary for the management and direction of a major weapon system. They do not require an extensive maintenance and repair program and do not need a large volume of TM information. Therefore, the APML, in conjunction with the LEMs, would develop an end item maintenance plan, or Operational Logistics Support Plan (OLSP). The OLSP identifies and defines known and anticipated logistics interface which would contribute to the ability to perform Documentation Requirements Analysis. A part of the OLSP is devoted to TMs that are an aid to task development.

(2) Large weapon system programs. Large weapon system projects will normally be supported by the Integrated Logistics Support (ILS) concept. This management approach includes a maintenance analysis known as LSA or LMI. The LSA/LMI is managed by the APML and the LEMs and is contractually controlled by a maintenance policy statement, or general maintenance plan, which stipulates the criteria for LSA/LMI. These documents define the manner in which the end item will be maintained, the maintenance level at which each support phase will be performed, and the depth and scope of the authorized repair.

c. Additional source data. Available engineering drawings shall be used with the other required data. Sound engineering principles and techniques, available engineering analyses service experience, performance data on the item and on similar items, and all other reliability, availability, and maintainability (RAM) data available shall be used in the preparation of specific technical information.

5.2 Work package development. Technical information developed in accordance with this standard shall be divided into individual, stand-alone units of information, hereafter referred to as WPs. A WP is specifically designed to respond to work tasks or to provide direct support of work tasks. WPs shall contain descriptive, operational, maintenance, testing and troubleshooting, support, and parts information for weapon systems, aeronautical equipment, airborne weapons/equipment, training systems, and support equipment. The technical information contained in these WPs shall be developed to the maintenance concepts described in [5.1](#).

5.2.1 Types of work packages. There are basically two types of WPs. The first type is an information-oriented WP. It provides information such as general information about the printed TM or the IETM and specific information about the weapon system/equipment, such as principles of operation and operating instructions. The second type of WP is task-oriented. Task-oriented WPs reflect all required maintenance tasks, including testing and troubleshooting, at the

MIL-STD-3001-1A(AS) w/CHANGE 1

assigned level of maintenance. Task-oriented WPs also contain supporting information such as required materials and support equipment required for each defined task. WPs are written to reflect the engineering design, LSA or LMI, LORA, approved maintenance plan, and the established repair concept (SM&R Codes).

5.3 Task analysis. The task development phase of TM preparation is critical because it will establish the organization and structure of the technical information and, together with the task analysis, will establish the depth and scope of the coverage. Based on maintenance requirements identified by the task analysis, all tasks and support data shall reflect end item operation and fault isolation/maintenance criteria at the appropriate level(s) of maintenance. The final output of the task development phase is the TM data outline.

5.3.1 Technical manual outline. The first step in the construction of a TM is the development of an outline to be reviewed and approved by the requiring activity. Refer to NAVAIR 00-25-604 for guidance on the preparation of a TM outline.

6. NOTES

(This section contains information of a general or explanatory nature that may be helpful, but is not mandatory.)

6.1 Intended use. TMs prepared in accordance with the requirements of MIL-STD-3001-1 through MIL-STD-3001-8 are intended for use in the repair of aircraft weapon systems, aeronautical equipment, airborne weapons/equipment, training systems, and support equipment at the organizational, intermediate, and depot maintenance levels.

6.2 Acquisition requirements. Acquisition documents should specify the following:

- a. Title, number, and date of this standard.

6.3 Tailoring guidance. The contracting activity should tailor any required options offered herein in accordance with [Appendix A](#).

6.4 Subject term (key word) listing. The following terms are to be used to identify the MIL-STD-3001-1 series documents during retrieval searches:

Card deck	Operational checkout
Description	Periodic maintenance requirements
Document type definition	Principles of operation
Graphics	Revisions
Hazardous materials warnings	Security classification
Icons	Structural repair
Illustrated parts breakdown	Testing
Illustrations	Troubleshooting information
Maintenance instructions	Wiring information
Operation instructions	Work package

MIL-STD-3001-1A(AS) w/CHANGE 1

6.5 Changes from previous issue. The margins of this standard are marked with vertical lines to indicate where changes from the previous issue were made. This was done as a convenience only and the Government assumes no liability whatsoever for any inaccuracies in these notations. Bidders and contractors are cautioned to evaluate the requirements of this document based on the entire content irrespective of the marginal notations and relationship to the previous issue.

MIL-STD-3001-1A(AS) w/CHANGE 1

APPENDIX A

APPENDIX A - TECHNICAL MANUAL CONTENT SELECTION MATRIXES**A.1 SCOPE**

A.1.1 Scope. This appendix contains tables that list all applicable technical content requirements for the development of the following maintenance level TMs. This Appendix is a mandatory part of this standard. The information contained herein is intended for compliance. Copies of the applicable tables will be completed and added as an attachment to the Technical Manual Contract Requirement (TMCR).

a. Aircraft systems and equipment maintenance instruction manuals.

General aircraft information manual

Plane captain's manual

Line maintenance manual

Principles of operation manual

Functional flow diagram manual

Testing and troubleshooting manual

Fault reporting manual

Fault isolation manual

Integrated weapon systems testing and troubleshooting manual

Maintenance instructions with IPB manual

Structural repair manual

Aircraft wiring diagram manual

Aircraft wire bundle manual

Aircraft wire connector repair manual

Power plant build-up manual

Periodic maintenance requirements card sets

Illustrated parts breakdown (IPB) manual.

b. Aeronautical equipment, airborne weapons/equipment, training systems, and support equipment operation and maintenance manuals.

Operation instructions manuals

Operation and maintenance instructions with IPB manuals

Maintenance instructions with IPB manuals.

c. Engine intermediate and depot maintenance manuals.

A.2 APPLICABLE DOCUMENTS

This section is not applicable to this appendix.

MIL-STD-3001-1A(AS) w/CHANGE 1

APPENDIX A

A.3 DEFINITIONS

This section is not applicable to this appendix.

A.4 GENERAL REQUIREMENTS

This section is not applicable to this appendix.

A.5 DETAILED REQUIREMENTS

A.5.1 General. [Tables A-I](#) through [A-XXXVI](#) simplify tailoring the technical content requirements of TMs prepared using this standard as a guide. The tables indicate which parts of MIL-STD-3001-1 are applicable and list the content requirements for each type of TM. The content requirements for each applicable TM shall be arranged in the order presented in the tables. Inclusion of the following applicable tables of this appendix is mandatory and is intended for compliance:

a. Aircraft systems and equipment maintenance instruction manuals.

General aircraft information manual ([Table A-I](#))

Plane captain's manual ([Table A-I](#))

Line maintenance manual ([Table A-I](#))

Description and principles of operation manual ([Table A-II](#))

Aircraft functional flow diagram manual ([Table A-III](#))

Aircraft testing and troubleshooting manual ([Table A-IV](#))

Integrated weapon systems testing and troubleshooting manual ([Table A-V](#))

Fault reporting manual ([Table A-VI](#))

Fault isolation manual ([Table A-VI](#))

Maintenance instructions with IPB manual ([Table A-VII](#))

Structural repair manual ([Table A-VIII](#))

Aircraft wiring diagram manual ([Table A-IX](#))

Aircraft wire bundle manual ([Table A-X](#))

Aircraft wire connector repair manual ([Table A-XI](#))

Power plant build-up manual ([Table A-XII](#))

Periodic maintenance requirements card sets:

Preoperational and turnaround checklist card decks ([Table A-XIII](#))

Phased maintenance card decks ([Table A-XIV](#))

Periodic maintenance information card decks ([Table A-XV](#))

Quick Engine Change (QEC) periodic maintenance requirements card decks ([Table A-XVI](#))

Powered Surface Target (PST) periodic maintenance requirements card decks ([Table A-XVII](#))

MIL-STD-3001-1A(AS) w/CHANGE 1

APPENDIX A

Aviation Life Support Systems (ALSS) periodic maintenance requirements card decks ([Table A-XVIII](#))

Aircraft daily, special, preservation, and conditional card decks ([Table A-XIX](#))

AAE or Special stores daily/special card decks ([Table XX](#))

Training Systems (TS)/Support Equipment (SE)/Automatic Test Equipment (ATE) daily, special, preservation, and conditional card decks ([Table A-XXI](#))

Airborne Mine Countermeasures (AMCM) daily and Unmanned Aerial Vehicle (UAV) daily inspect/daily inspect and servicing card decks ([Table A-XXII](#))

AMCM and UAV special, preservation, and conditional card decks ([Table A-XXIII](#))

SE/ATE, AMCM and UAV calendar, hour, and start card decks ([Table A-XXIV](#))

PAT prelaunch and post launch servicing card decks ([Table A-XXV](#))

Powered Aerial Target (PAT) acceptance/initial buildup card decks ([Table A-XXVI](#))

Illustrated Parts Breakdown (IPB) manual ([Table A-XXVII](#))

b. Aeronautical equipment, airborne weapons/equipment, training systems, and support equipment operation and maintenance manuals.

Operation instructions manual ([Table A-XXVIII](#))

Operation and maintenance instructions with IPB manual ([Table A-XXIX](#))

Training systems operation and maintenance instructions with IPB manual ([Table A-XXX](#))

Maintenance instructions with IPB manuals ([Table A-XXXI](#))

c. Engine intermediate and depot maintenance manual. ([Table A-XXXII](#))

d. Interactive electronic technical manuals (IETMs).

Aircraft systems and equipment maintenance IETMs ([Table A-XXXIII](#))

Aeronautical equipment, airborne weapons/equipment, and support equipment operation and maintenance IETMs ([Table A-XXXIV](#))

Training systems operation and maintenance IETMs ([Table A-XXXV](#))

Engine intermediate and depot maintenance IETMs ([Table A-XXXVI](#))

A.5.2 Intended use. Tables [A-I](#) through [A-XXXVI](#) may be used by the requiring activity or the weapons system contractor to tailor technical content requirements for individual TMs. In most instances, the approved maintenance plan (MP), logistics support analysis (LSA) or logistics management information (LMI) shall be used to determine what mandatory or optional requirements are to be included. The "REMARKS" column may be used to identify the TM content that is required (R) or not required (NR) by placing "R" or "NR" in that column.

A.5.3 Acquisition requirements. A properly executed Technical Manual Content Selection Matrix table may be used, filled out either by the requiring activity or the weapons system contractor, as a final TM outline.

MIL-STD-3001-1A(AS) w/CHANGE 1

APPENDIX A

TABLE A-I. GENERAL AIRCRAFT INFORMATION MANUAL, PLANE CAPTAIN'S MANUAL AND LINE MAINTENANCE MANUAL*

TM CONTENTS	MIL-STD-3001-1 REFERENCE	ELEMENT NAME	REMARKS
TM FRONT MATTER AND SUPPORTING INFORMATION	1-B.5.3.1		
Title page	1-B.5.3.1.1	<titlepg>	
Numerical index of effective work packages/pages (A page)	1-B.5.3.1.2	<niewp>	
TPDR page	1-B.5.3.1.3	<tpdrpg>	
HMWS WP	1-B.5.3.1.4	<hmwswp>	
Alphabetical index WP	1-B.5.3.1.5	<alphaindxwp>	
Introduction WP	1-B.5.3.2.1.3.3	<introwp>	
Consolidated lists for technical directives, support equipment, materials and references WP	1-B.5.3.2.1.3.4	<consolistwp>	
WORK PACKAGE FRONT MATTER			
Title block	2-5.2.1	<titleblk>	
Work package information	2-5.2.2	<wpinfo>	
Reference material list	2-5.2.2.1	<reflist>	
Record of applicable technical directives	2-5.2.2.2	<ratd>	
Support equipment required list	2-5.2.2.3	<selist>	
DESCRIPTION WORK PACKAGES	2-5.2.4		
Introduction	2-5.2.4.1	<intro>	
Aircraft general description work package	2-5.2.4.1.1	<acdescwp>	
Aircraft description	2-5.2.4.1.1.1	<acdesc>	
Aircraft dimensions	2-5.2.4.1.1.2	<acdim>	
Aircraft materials distribution	2-5.2.4.1.1.3	<acmats>	
Aircraft arrangement work package	2-5.2.4.1.2	<acarrgwp>	
Aircraft systems description work package	2-5.2.4.1.3	<acsysdescwp>	
Aircraft instrument panel location work package	2-5.2.4.1.4	<acpnlpwp>	
Danger areas and precautionary measures work package	2-5.2.4.1.5	<dangarwp>	
Aircraft stations work package	2-5.2.4.1.6	<acstawp>	
Aircraft dimensions work package	2-5.2.4.1.7	<acdimwp>	
Aircraft access and inspection panels and provisions work package	2-5.2.4.1.8	<acacesswp>	
Aircraft external power source connections work package	2-5.2.4.1.9	<acextpwrwp>	
ENGINE START AND RUN-UP WORK PACKAGE			
Introduction	4-5.3	<intro>	
Engine start and run-up	4-5.3.1.1.15	<engstart>	
GROUND OPERATIONS WORK PACKAGES	4-5.3.4	<grndopwp>	
Introduction	4-5.3	<intro>	
Handling	4-5.3.1.1.3.1	<handling>	
Folding and unfolding wings	4-5.3.1.1.3.1a	<fold>	
Cockpit entry and safety check	4-5.3.1.1.3.1b	<cock>	
Towing	4-5.3.1.1.3.1c	<tow>	
Moving	4-5.3.1.1.3.1d	<move>	
Parking	4-5.3.1.1.3.1e	<park>	
Mooring	4-5.3.1.1.3.1f	<moor>	
Jacking	4-5.3.1.1.3.1g	<jack>	
Hoisting	4-5.3.1.1.3.1h	<hoist>	
Leveling	4-5.3.1.1.3.1i	<level>	
Protective covers	4-5.3.1.1.3.1j	<procover>	
Ground safety locks and pins	4-5.3.1.1.3.1k	<safelock>	
Carrier deck handling	4-5.3.1.1.3.1l	<cardckhdl>	
Preparation for catapulting	4-5.3.1.1.3.1m	<prepcat>	

MIL-STD-3001-1A(AS) w/CHANGE 1

APPENDIX A

TABLE A-I. GENERAL AIRCRAFT INFORMATION MANUAL, PLANE CAPTAIN'S MANUAL AND LINE MAINTENANCE MANUAL*

TM CONTENTS	MIL-STD-3001-1 REFERENCE	ELEMENT NAME	REMARKS
Loading	4-5.3.1.1.3.1n	<load>	
Unloading	4-5.3.1.1.3.1o	<unload>	
Arrested landing operation	4-5.3.1.1.3.1p	<arrlndop>	
Fueling	4-5.3.1.1.3.1q	<fuelproc>	
Defueling	4-5.3.1.1.3.1r	<defuelproc>	
SAFETY WORK PACKAGES			
Introduction	4-5.3	<intro>	
Safety information	4-5.3.1.1.14	<safe>	
SERVICING WORK PACKAGES			
Introduction	4-5.3	<intro>	
Servicing work package	4-5.3.3	<servicewp>	

*The technical content provided in this matrix is normally used to develop a General Aircraft Information Manual, a Plane Captain's Manual and/or a Line Maintenance Manual; the requiring activity shall provide guidance as to the technical content of each manual.

MIL-STD-3001-1A(AS) w/CHANGE 1

APPENDIX A

TABLE A-II. AIRCRAFT DESCRIPTION AND PRINCIPLES OF OPERATION MANUAL

TM CONTENTS	MIL-STD-3001-1 REFERENCE	ELEMENT NAME	REMARKS
TM FRONT MATTER AND SUPPORTING INFORMATION	1-B.5.3.1		
Title page	1-B.5.3.1.1	<titlepg>	
Numerical index of effective work packages/pages (A page)	1-B.5.3.1.2	<niewp>	
TPDR page	1-B.5.3.1.3	<tpdrpg>	
Alphabetical index WP	1-B.5.3.1.5	<alphaindxwp>	
Introduction WP	1-B.5.3.2.1.3.3	<introwp>	
Consolidated lists for technical directives, support equipment, materials, and references WP	1-B.5.3.2.1.3.4	<consolistwp>	
WORK PACKAGE FRONT MATTER			
Title block	2-5.2.1	<titleblk>	
Work package information	2-5.2.2	<wpinfo>	
Reference material list	2-5.2.2.1	<reflist>	
Record of applicable technical directives	2-5.2.2.2	<ratd>	
AIRCRAFT SYSTEM, SUBSYSTEM AND COMPONENT DESCRIPTION WORK PACKAGES	2-5.2.4.2.1	<descwp>	
Introduction	2-5.2.4.2	<intro>	
System description	2-5.2.4.2.1	<sysdesc>	
Subsystem description	2-5.2.4.2.1	<sysdesc>	
Component description	2-5.2.4.2.1	<sysdesc>	
Controls and indicator descriptions	2-5.2.4.2.1.1	<ctrlinddesc>	
PROGRAMMING SOFTWARE DESCRIPTION WORK PACKAGES	2-5.2.4.2.4	<softwp>	
Introduction	2-5.2.4.2.4	<intro>	
Stimulus and measurement programming	2-5.2.4.2.4	<stim-measdesc>	
Programming statements	2-5.2.4.2.4	<statedesc>	
Programming tests or self tests	2-5.2.4.2.4	<progtstdesc>	
PRINCIPLES OF OPERATION WORK PACKAGES	2-5.2.5		
Aircraft weapon systems principles of operation work packages	2-5.2.5.1	<popwp>	
Introduction	2-5.2.5.1	<intro>	
System description	2-5.2.4.2.1	<sysdesc>	
Weapon system principles of operation	2-5.2.5.1	<systhy>	
Subsystem description	2-5.2.4.2.1	<sysdesc>	
Subsystem principles of operation	2-5.2.5.1	<systhy>	
Component description	2-5.2.4.2.1	<sysdesc>	
Component principles of operation	2-5.2.5.1	<systhy>	
SCHEMATIC DIAGRAM WORK PACKAGES	2-5.2.5.4	<schemwp>	
Introduction	2-5.2.5.4	<intro>	

MIL-STD-3001-1A(AS) w/CHANGE 1

APPENDIX A

TABLE A-III. AIRCRAFT FUNCTIONAL FLOW DIAGRAM MANUAL

TM CONTENTS	MIL-STD-3001-1 REFERENCE	ELEMENT NAME	REMARKS
TM FRONT MATTER AND SUPPORTING INFORMATION	1-B.5.3.1		
Title page	1-B.5.3.1.1	<titlepg>	
Numerical index of effective work packages/pages (A page)	1-B.5.3.1.2	<niewp>	
TPDR page	1-B.5.3.1.3	<tpdrpg>	
Alphabetical index WP	1-B.5.3.1.5	<alphaindxwp>	
Introduction WP	1-B.5.3.2.1.3.3	<introwp>	
Consolidated lists for technical directives, support equipment, materials, and references WP	1-B.5.3.2.1.3.4	<consolistwp>	
WORK PACKAGE FRONT MATTER			
Title block	3-5.3.1	<titleblk>	
Work package information	3-5.3.2	<wpinfo>	
Reference material list	3-5.3.2.1	<reflist>	
Record of applicable technical directives	3-5.3.2.2	<ratd>	
FUNCTIONAL FLOW DIAGRAM DATA			
Functional flow diagram WPs	3-5.3.4.7	<ffdiagwp>	
Functional flow diagram technical content requirements	3-5.3.4.7.1	<ffdiagram>	

MIL-STD-3001-1A(AS) w/CHANGE 1

APPENDIX A

TABLE A-IV. AIRCRAFT TESTING AND TROUBLESHOOTING MANUAL

TM CONTENTS	MIL-STD-3001-1 REFERENCE	ELEMENT NAME	REMARKS
TM FRONT MATTER AND SUPPORTING INFORMATION	1-B.5.3.1		
Title page	1-B.5.3.1.1	<titlepg>	
Numerical index of effective work packages/pages (A page)	1-B.5.3.1.2	<niewp>	
TPDR page	1-B.5.3.1.3	<tpdrpg>	
HMWS WP	1-B.5.3.1.4	<hmwswp>	
Alphabetical index WP	1-B.5.3.1.5	<alphaindxwp>	
Introduction WP	1-B.5.3.2.1.3.3	<introwp>	
Consolidated lists for technical directives, support equipment, materials, and references WP	1-B.5.3.2.1.3.4	<consolistwp>	
WORK PACKAGE FRONT MATTER	3-5.3		
Title block	3-5.3.1	<titleblk>	
Work package information	3-5.3.2	<wpinfo>	
Reference material list	3-5.3.2.1	<reflist>	
Record of applicable technical directives	3-5.3.2.2	<ratd>	
Support equipment required list	3-5.3.2.3	<selist>	
Facilities required list	3-5.3.2.4	<facelist>	
Materials required list	3-5.3.2.5	<matlist>	
TESTING AND TROUBLESHOOTING DATA	3-5.1, 3-5.1.2, 3-5.2, 3-5.3.4		
OPERATIONAL CHECKOUT AND TROUBLESHOOTING PROCEDURES	3-5.3.4.6		
Operational checkout WP	3-5.3.4.6.3	<opchkwp>	
Introduction	3-5.3.4.6.3a	<intro>	
General procedures and precautions	3-5.3.4.6.3b	<genproc>	
Pretest setup procedures	3-5.3.4.6.3c	<pretest>	
Operational checkout procedures	3-5.3.4.6.3d	<opchk>	
Post-operational shutdown procedures	3-5.3.4.6.3e	<shutdown>	
Schematic diagram WP	3-5.3.4.6.1	<schemwp>	
Introduction	3-5.3.4.6.1	<intro>	
Troubleshooting WP	3-5.3.4.6.4	<trblshtwp>	
Introduction	3-5.3.4.6.4a	<intro>	
General procedures and precautions	3-5.3.4.6.4b	<genproc>	
Troubleshooting procedures	3-5.3.4.6.4c	<trblsht>	
Post-operational shutdown procedures	3-5.3.4.6.4d	<shutdown>	
Schematic diagram WP	3-5.3.4.6.1	<schemwp>	
Introduction	3-5.3.4.6.1	<intro>	
Combined operational checkout and troubleshooting WP	3-5.3.4.6.5	<tst-trblwp>	
Introduction	3-5.3.4.6.5a	<intro>	
General procedures and precautions	3-5.3.4.6.5b	<genproc>	
Pretest setup procedures	3-5.3.4.6.5c	<pretest>	
Operational checkout and troubleshooting procedures	3-5.3.4.6.5d	<opck-trblproc>	
Post-operational shutdown procedures	3-5.3.4.6.5e	<shutdown>	
Schematic diagram WP	3-5.3.4.6.1	<schemwp>	
Introduction	3-5.3.4.6.1	<intro>	

MIL-STD-3001-1A(AS) w/CHANGE 1

APPENDIX A

TABLE A-V. INTEGRATED WEAPON SYSTEMS TESTING AND TROUBLESHOOTING MANUAL

TM CONTENTS	MIL-STD-3001-1 REFERENCE	ELEMENT NAME	REMARKS
TM FRONT MATTER AND SUPPORTING INFORMATION	1-B.5.3.1		
Title page	1-B.5.3.1.1	<titlepg>	
Numerical index of effective work packages/pages (A page)	1-B.5.3.1.2	<niewp>	
TPDR page	1-B.5.3.1.3	<tpdrpg>	
HMWS WP	1-B.5.3.1.4	<hmwswp>	
Alphabetical index WP	1-B.5.3.1.5	<alphaindswp>	
Introduction WP	1-B.5.3.2.1.3.3	<introwp>	
Consolidated lists for technical directives, support equipment, materials, and references WP	1-B.5.3.2.1.3.4	<consolistwp>	
WORK PACKAGE FRONT MATTER			
Title block	3-5.3.1	<titleblk>	
Work package information	3-5.3.2	<wpinfo>	
Reference material list	3-5.3.2.1	<reflist>	
Record of applicable technical directives	3-5.3.2.2	<ratd>	
Support equipment required list	3-5.3.2.3	<selist>	
Facilities required list	3-5.3.2.4	<facelist>	
Materials required list	3-5.3.2.5	<matlist>	
INTEGRATED WEAPON SYSTEMS TESTING AND TROUBLESHOOTING DATA	3-5.1, 3-5.1.2.2, 3-5.2, 3-5.3.4		
OPERATIONAL CHECKOUT AND TROUBLESHOOTING PROCEDURES	3-5.3.4.6		
Operational checkout WPs	3-5.3.4.6.3	<opchkwp>	
Introduction	3-5.3.4.6.3a	<intro>	
General procedures and precautions	3-5.3.4.6.3b	<genproc>	
Pretest setup procedures	3-5.3.4.6.3c	<pretest>	
Operational checkout procedures	3-5.3.4.6.3d	<opchk>	
Post-operational shutdown procedures	3-5.3.4.6.3e	<shutdown>	
Schematic diagram WPs	3-5.3.4.6.1	<schemwp>	
Introduction	3-5.3.4.6.1	<intro>	
Troubleshooting WPs	3-5.3.4.6.4	<trblshtwp>	
Introduction	3-5.3.4.6.4a	<intro>	
General procedures and precautions	3-5.3.4.6.4b	<genproc>	
Troubleshooting procedures	3-5.3.4.6.4c	<trblsht>	
Post-operational shutdown procedures	3-5.3.4.6.4d	<shutdown>	
Schematic diagram WPs	3-5.3.4.6.1	<schemwp>	
Introduction	3-5.3.4.6.1	<intro>	
Combined operational checkout and troubleshooting WPs	3-5.3.4.6.5	<tst-trblwp>	
Introduction	3-5.3.4.6.5a	<intro>	
General procedures and precautions	3-5.3.4.6.5b	<genproc>	
Pretest setup procedures	3-5.3.4.6.5c	<pretest>	
Operational checkout and troubleshooting procedures	3-5.3.4.6.5d	<opck-trblproc>	
Post-operational shutdown procedures	3-5.3.4.6.5e	<shutdown>	
Schematic diagram WPs	3-5.3.4.6.1	<schemwp>	
Introduction	3-5.3.4.6.1	<intro>	

MIL-STD-3001-1A(AS) w/CHANGE 1

APPENDIX A

TABLE A-VI. FAULT REPORTING MANUAL AND FAULT ISOLATION MANUAL

TM CONTENTS	MIL-STD-3001-1 REFERENCE	ELEMENT NAME	REMARKS
TM FRONT MATTER AND SUPPORTING INFORMATION	1-B.5.3.1		
Title page	1-B.5.3.1.1	<titlepg>	
Numerical index of effective work packages/pages (A page)	1-B.5.3.1.2	<niewp>	
TPDR page	1-B.5.3.1.3	<tpdrpg>	
Alphabetical index WP	1-B.5.3.1.5	<alphaindwp>	
Introduction WP	1-B.5.3.2.1.3.3	<introwp>	
Consolidated lists for technical directives, support equipment, materials, and references WP	1-B.5.3.2.1.3.4	<consolistwp>	
WORK PACKAGE FRONT MATTER			
Title block	3-5.3.1	<titleblk>	
Work package information	3-5.3.2	<wpinfo>	
Reference material list	3-5.3.2.1	<reflist>	
Record of applicable technical directives	3-5.3.2.2	<ratd>	
Support equipment required list	3-5.3.2.3	<selist>	
Facilities required list	3-5.3.2.4	<faclist>	
Materials required list	3-5.3.2.5	<matlist>	
FAULT REPORTING/FAULT ISOLATION WORK PACKAGES			
Maintenance code listing WP	3-5.3.4.1	<maintcdwp>	
Fault indications WP	3-5.3.4.2	<fltindwp>	
Fault descriptor WP	3-5.3.4.3	<fltdescrptwp>	
Symbology WPs	3-5.3.4.4	<symwp>	
Fault isolation troubleshooting procedure WPs	3-5.3.4.5	<fitrblwp>	

MIL-STD-3001-1A(AS) w/CHANGE 1

APPENDIX A

TABLE A-VII. MAINTENANCE INSTRUCTIONS WITH IPB MANUAL

TM CONTENTS	MIL-STD-3001-1 REFERENCE	ELEMENT NAME	REMARKS
TM FRONT MATTER AND SUPPORTING INFORMATION	1-B.5.3.1		
Title page	1-B.5.3.1.1	<titlepg>	
Numerical index of effective work packages/pages (A page)	1-B.5.3.1.2	<niewp>	
TPDR page	1-B.5.3.1.3	<tpdrpg>	
HMWS WP	1-B.5.3.1.4	<hmwswp>	
Alphabetical index WP	1-B.5.3.1.5	<alphaindxwp>	
Numerical index of part numbers WP	1-B.5.3.2.1.3.1	<partnoindxwp>	
Numerical index of reference designations WP	1-B.5.3.2.1.3.2	<refdesindxwp>	
Introduction WP	1-B.5.3.2.1.3.3	<introwp>	
Consolidated lists for technical directives, support equipment, materials, and references WP	1-B.5.3.2.1.3.4	<consolistwp>	
WORK PACKAGE FRONT MATTER			
Title block	4-5.2.1	<titleblk>	
Work package information	4-5.2.2	<wpinfo>	
Reference material list	4-5.2.2.1	<reflist>	
Record of applicable technical directives	4-5.2.2.2	<ratd>	
Support equipment required list	4-5.2.2.3	<selist>	
Facilities required list	4-5.2.2.4	<faclist>	
Materials required list	4-5.2.2.5	<matlist>	
MAINTENANCE INFORMATION WITH IPB	4-5.3		
Maintenance work packages	4-5.3.1	<maintwp>	
Introduction	4-5.3	<intro>	
Maintenance tasks	4-5.3.1.1		
Preparation for use and assembly	4-5.3.1.1a, 4-5.3.1.1.2	<prepuse>	
Handling	4-5.3.1.1b, 4-5.3.1.1.3	<handling>	
Stowage	4-5.3.1.1c	<stow>	
Removal	4-5.3.1.1d, 4-5.3.1.1.4	<remove>	
Disassembly	4-5.3.1.1e, 4-5.3.1.1.5	<dissam>	
Cleaning and corrosion control	4-5.3.1.1f, 4-5.3.1.1.6	<clncorr>	
Inspection	4-5.3.1.1g, 4-5.3.1.1.7	<insp>	
Service	4-5.3.1.1h	<service>	
Repair	4-5.3.1.1i, 4-5.3.1.1.8	<repair>	
Alignment	4-5.3.1.1j	<align>	
Painting	4-5.3.1.1k	<paint>	
Lubrication	4-5.3.1.1l	<lube>	
Assembly	4-5.3.1.1m, 4-5.3.1.1.9	<assem>	
Test and inspection	4-5.3.1.1n, 4-5.3.1.1.10	<test-inspect>	
Installation	4-5.3.1.1o, 4-5.3.1.1.11	<install>	
Rigging	4-5.3.1.1p	<rig>	
Adjustment	4-5.3.1.1q	<adjust>	
Calibration	4-5.3.1.1r, 4-5.3.1.1.12	<calibrate>	

MIL-STD-3001-1A(AS) w/CHANGE 1

APPENDIX A

TABLE A-VII. MAINTENANCE INSTRUCTIONS WITH IPB MANUAL

TM CONTENTS	MIL-STD-3001-1 REFERENCE	ELEMENT NAME	REMARKS
Preparation for storage or shipment	4-5.3.1.1s, 4-5.3.1.1.13	<pss>	
Environmental conditioning	4-5.3.1.1t	<envircond>	
Safety information	4-5.3.1.1u, 4-5.3.1.1.14	<safe>	
Engine start and run-up	4-5.3.1.1v, 4-5.3.1.1.15	<engstart>	
Software loading	4-5.3.1.1w	<softload>	
Fabrication	4-5.3.1.1x, 4-5.3.1.1.16	<fabricate>	
Packing	4-5.3.1.1y	<packing>	
Unpacking	4-5.3.1.1z	<unpacking>	
Preservation	4-5.3.1.1aa	<preserve>	
Tracking	4-5.3.1.1ab	<track>	
Fueling	4-5.3.1.1ac	<fuel>	
Defueling	4-5.3.1.1ad	<defuel>	
Canning	4-5.3.1.1ae	<canning>	
Decanning	4-5.3.1.1af	<decanning>	
General maintenance procedures work package	4-5.3.2	<genmaintwp>	
Support equipment maintenance work package	4-5.3.5	<semaintwp>	
Local manufacturing and assembly work package	4-5.3.6	<locmfgwp>	
IPB data (as applicable for maintenance WPs listed above)	4-5.3.11	<ipbwp>	
Wiring/cabling diagram work packages	4-5.3.12	<wirediawp>	
Wire run lists work packages	4-5.3.13	<wirelistwp>	

MIL-STD-3001-1A(AS) w/CHANGE 1

APPENDIX A

TABLE A-VIII. AIRCRAFT STRUCTURAL REPAIR MANUAL

TM CONTENTS	MIL-STD-3001-1 REFERENCE	ELEMENT NAME	REMARKS
TM FRONT MATTER AND SUPPORTING INFORMATION	1-B.5.3.1		
Title page	1-B.5.3.1.1	<titlepg>	
Numerical index of effective work packages/pages (A page)	1-B.5.3.1.2	<niewp>	
TPDR page	1-B.5.3.1.3	<tpdrpg>	
HMWS WP	1-B.5.3.1.4	<hmwswp>	
Alphabetical index WP	1-B.5.3.1.5	<alphaindxwp>	
Introduction WP	1-B.5.3.2.1.3.3	<introwp>	
WORK PACKAGE FRONT MATTER			
Title block	6-5.2.1	<titleblk>	
Work package information	6-5.2.2	<wpinfo>	
Reference material list	6-5.2.2.1	<reflist>	
Record of applicable technical directives	6-5.2.2.2	<ratd>	
Support equipment required list	6-5.2.2.3	<selist>	
Facilities required list	6-5.2.2.4	<faclist>	
Materials required list	6-5.2.2.5	<matlist>	
STRUCTURAL REPAIR INFORMATION WPs	6-5.2.3		
AIRCRAFT STRUCTURE VISUAL INDEX WP	6-5.2.3.1	<repindxwp>	
Introduction	6-5.2.3	<intro>	
Visual index	6-5.2.3.1	<repindx>	
GENERAL AIRCRAFT STRUCTURAL INFORMATION WP	6-5.2.3.2	<genstructwp>	
Introduction	6-5.2.3	<intro>	
Aircraft structural description	6-5.2.3.2.1	<structrepair>	
Aircraft leveling and alignment	6-5.2.3.2.2	<structrepair>	
Contour data	6-5.2.3.2.3	<structrepair>	
In-service tolerance	6-5.2.3.2.4	<structrepair>	
Common shop practices	6-5.2.3.2.5	<structrepair>	
Repair materials	6-5.2.3.2.6	<structrepair>	
Support of structure	6-5.2.3.2.7	<structrepair>	
Crash handling and shipping	6-5.2.3.2.8	<structrepair>	
TYPICAL REPAIR DATA WPs	6-5.2.3.3	<typreppwp>	
Introduction	6-5.2.3	<intro>	
Skin patch repair	6-5.2.3.3a	<typrepproc>	
Transparent panel repair	6-5.2.3.3b	<typrepproc>	
Honeycomb structure repair	6-5.2.3.3c	<typrepproc>	
Extrusion repair	6-5.2.3.3d	<typrepproc>	
Sealed area repair	6-5.2.3.3e	<typrepproc>	
Formed structure repair	6-5.2.3.3f	<typrepproc>	
Plastic repair	6-5.2.3.3g	<typrepproc>	
New/peculiar structure repair	6-5.2.3.3.1	<typrepproc>	
SPECIFIC REPAIR DATA WPs	6-5.2.3.4	<specrepwp>	
Introduction	6-5.2.3	<intro>	
Damage identification and evaluation data	6-5.2.3.4.1	<damage>	
Typical repair procedures	6-5.2.3.4.2	<typrepproc>	
Aircraft specific repair procedures	6-5.2.3.4.3	<specrepproc>	
Illustrated parts breakdown data	6-5.2.3.4.3.8, 6-5.2.6	<ipb-structdata>	
CORROSION CONTROL REPAIR INFORMATION	6-5.2.4		
CORROSION CONTROL MATERIALS REQUIREMENTS WP	6-5.2.4.1	<cormatwp>	
Introduction	6-5.2.4	<intro>	
Corrosion control materials list	6-5.2.4.1	<cormatlist>	

MIL-STD-3001-1A(AS) w/CHANGE 1

APPENDIX A

TABLE A-VIII. AIRCRAFT STRUCTURAL REPAIR MANUAL

TM CONTENTS	MIL-STD-3001-1 REFERENCE	ELEMENT NAME	REMARKS
GENERAL INFORMATION WP	6-5.2.4.2	<geninfowp>	
Introduction	6-5.2.4	<intro>	
Protective covers	6-5.2.4.2.1	<titledpara>	
Corrosion prone areas	6-5.2.4.2.2	<titledpara>	
CORROSION CONTROL PRACTICES WPs	6-5.2.4.3		
TYPICAL CORROSION CONTROL DATA WPs	6-5.2.4.3.1	<typcorwp>	
Introduction	6-5.2.4	<intro>	
Typical procedures	6-5.2.4.3.1	<titledpara>	
INSPECTION FOR CORROSION WP	6-5.2.4.3.2	<corinspwp>	
Introduction	6-5.2.4	<intro>	
Cleaning procedures	6-5.2.4.3.2a	<titledpara>	
Inspection by methods appropriate to the area on the aircraft	6-5.2.4.3.2b	<titledpara>	
References	6-5.2.4.3.2c	<titledpara>	
Criteria for recognizing and evaluating corrosion damage	6-5.2.4.3.2d	<titledpara>	
CLEANING WPs	6-5.2.4.3.3	<corclnwp>	
Introduction	6-5.2.4	<intro>	
Cleaning procedures	6-5.2.4.3.3	<structrepair>	
STRIPPING WPs	6-5.2.4.3.4	<stripwp>	
Introduction	6-5.2.4	<intro>	
Stripping procedures	6-5.2.4.3.4	<strip>	
CORROSION REMOVAL WPs	6-5.2.4.3.5	<corremwp>	
Introduction	6-5.2.4	<intro>	
Corrosion removal procedures	6-5.2.4.3.5	<proc>	
CHEMICAL TREATMENT OF METAL SURFACES WPs	6-5.2.4.3.6	<chemtrtwp>	
Introduction	6-5.2.4	<intro>	
Chemical treatment procedures	6-5.2.4.3.6	<structrepair>	
CORROSION CONTROL SEALS AND SEALANTS WPs	6-5.2.4.3.7	<corsealwp>	
Introduction	6-5.2.4	<intro>	
Seals and sealants procedures	6-5.2.4.3.7	<structrepair>	
PAINT SYSTEMS WPs	6-5.2.4.3.8	<paintsyswp>	
Introduction	6-5.2.4	<intro>	
Exterior marking	6-5.2.4.3.8.1	<titledpara>	
Interior markings	6-5.2.4.3.8.2	<titledpara>	
NONDESTRUCTIVE INSPECTION (NDI) DATA	6-5.2.5		
NDI GENERAL INFORMATION WP	6-5.2.5.1	<ndigeninfowp>	
Introduction	6-5.2.5	<intro>	
General information	6-5.2.5.1	<titledpara>	
NDI TYPICAL PROCEDURES WPs	6-5.2.5.2	<nditypwp>	
Introduction	6-5.2.5	<intro>	
Typical procedures	6-5.2.5.2	<structrepair>	
NDI INDEX WP	6-5.2.5.3	<ndindxwp>	
Introduction	6-5.2.5	<intro>	
NDI Index	6-5.2.5.3	<ndindx>	
NDI SPECIFIC PROCEDURES WPs	6-5.2.5.4	<ndispecwp>	
Introduction	6-5.2.5	<intro>	
Item nomenclature	6-5.2.5.4.1	<itemnom>	
Item description	6-5.2.5.4.2	<itemdesc>	
Defect description	6-5.2.5.4.3	<defdesc>	
Primary NDI procedure	6-5.2.5.4.4	<priproc>	
Backup NDI procedure	6-5.2.5.4.5	<bkupproc>	

MIL-STD-3001-1A(AS) w/CHANGE 1

APPENDIX A

TABLE A-IX. AIRCRAFT WIRING DIAGRAM MANUAL

TM CONTENTS	MIL-STD-3001-1 REFERENCE	ELEMENT NAME	REMARKS
TM FRONT MATTER AND SUPPORTING INFORMATION	1-B.5.3.1		
Title page	1-B.5.3.1.1	<titlepg>	
Numerical index of effective work packages/pages (A page)	1-B.5.3.1.2	<niewp>	
TPDR page	1-B.5.3.1.3	<tpdrpg>	
Alphabetical index WP	1-B.5.3.1.5	<alphaindwp>	
Introduction WP	1-B.5.3.2.1.3.3	<introwp>	
WIRING DIAGRAM IDENTIFICATION AND INFORMATION WP	5-5.2.3.2	<wdiawp>	
Title block	5-5.2.1	<titleblk>	
Introduction	5-5.2.3.2a	<intro>	
Reference designation system	5-5.2.3.2b	<titledpara>	
Individual cable numbering	5-5.2.3.2c	<titledpara>	
Electrical connector identification	5-5.2.3.2d	<titledpara>	
Splice area identification	5-5.2.3.2e	<titledpara>	
Ground point identification	5-5.2.3.2f	<titledpara>	
Individual wire identification	5-5.2.3.2g	<titledpara>	
WIRING DIAGRAM WPs	5-5.2.3.3	<wdiawp>	
WIRE LIST WPs	5-5.2.3.4		
Wire run list WP	5-5.2.3.4.1	<wrunlstwp>	
Wiring reference designation list WP	5-5.2.3.4.2	<wrefdeswp>	
Wire and connector component identification and location list WP	5-5.2.3.5	<wcomplstwp>	

MIL-STD-3001-1A(AS) w/CHANGE 1

APPENDIX A

TABLE A-X. AIRCRAFT WIRE BUNDLE MANUAL

TM CONTENTS	MIL-STD-3001-1 REFERENCE	ELEMENT NAME	REMARKS
TM FRONT MATTER AND SUPPORTING INFORMATION	1-B.5.3.1		
Title page	1-B.5.3.1.1	<titlepg>	
Numerical index of effective work packages/pages (A page)	1-B.5.3.1.2	<niewp>	
TPDR page	1-B.5.3.1.3	<tpdrpg>	
Alphabetical index WP	1-B.5.3.1.5	<alphaindxwp>	
Introduction WP	1-B.5.3.2.1.3.3	<introwp>	
WORK PACKAGE FRONT MATTER			
Title block	5-5.2.1	<titleblk>	
Work package information	5-5.2.2	<wpinfo>	
Reference material list	5-5.2.2.1	<reflist>	
Record of applicable technical directives	5-5.2.2.2	<ratd>	
Support equipment required list	5-5.2.2.3	<selist>	
Facilities required list	5-5.2.2.4	<faclist>	
Materials required list	5-5.2.2.5	<matlist>	
WIRING SYSTEM BUNDLE ASSEMBLY IDENTIFICATION AND INFORMATION WP	5-5.2.4.1	<bunidwp>	
Introduction	5-5.2.4.1a	<intro>	
Reference designator system	5-5.2.4.1b	<titledpara>	
Aircraft section identification	5-5.2.4.1c	<titledpara>	
Individual harness identification	5-5.2.4.1d	<titledpara>	
Individual cable numbering	5-5.2.4.1e	<titledpara>	
Electrical connector identification	5-5.2.4.1f	<titledpara>	
Splice area identification	5-5.2.4.1g	<titledpara>	
Ground point identification	5-5.2.4.1h	<titledpara>	
Individual wire identification	5-5.2.4.1i	<titledpara>	
Circuit identification	5-5.2.4.1j	<titledpara>	
ACCESS INFORMATION WP	5-5.2.4.2	<accessinfowp>	
Introduction	5-5.2.4.2	<intro>	
Access information	5-5.2.4.2	<accessinfo>	
WIRE BUNDLE ASSEMBLY ROUTINGS WPs	5-5.2.4.3	<bunroutewp>	
Introduction	5-5.2.4.3	<intro>	
Wire bundle assembly routing information	5-5.2.4.3	<titledpara>	
Bundle routing parts list	5-5.2.4.3	<bunroutepl>	

MIL-STD-3001-1A(AS) w/CHANGE 1

APPENDIX A

TABLE A-XI. AIRCRAFT WIRE CONNECTOR REPAIR MANUAL

TM CONTENTS	MIL-STD-3001-1 REFERENCE	ELEMENT NAME	REMARKS
TM FRONT MATTER AND SUPPORTING INFORMATION	1-B.5.3.1		
Title page	1-B.5.3.1.1	<titlepg>	
Numerical index of effective work packages/pages (A page)	1-B.5.3.1.2	<niewp>	
TPDR page	1-B.5.3.1.3	<tpdrpg>	
HMWS WP	1-B.5.3.1.4	<hmwswp>	
Alphabetical index WP	1-B.5.3.1.5	<alphaindxwp>	
Introduction WP	1-B.5.3.2.1.3.3	<introwp>	
WORK PACKAGE FRONT MATTER			
Title block	5-5.2.1	<titleblk>	
Work package information	5-5.2.2	<wpinfo>	
Reference material list	5-5.2.2.1	<reflist>	
Record of applicable technical directives	5-5.2.2.2	<ratd>	
Support equipment required list	5-5.2.2.3	<selist>	
Facilities required list	5-5.2.2.4	<faclist>	
Materials required list	5-5.2.2.5	<matlist>	
WIRING SYSTEMS REPAIR IDENTIFICATION AND INFORMATION WP	5-5.2.5.2	<wrepidwp>	
Introduction	5-5.2.5.2a	<intro>	
Reference designator system	5-5.2.5.2b	<titledpara>	
Electrical connector identification	5-5.2.5.2c	<titledpara>	
Splice area identification	5-5.2.5.2d	<titledpara>	
Ground point identification	5-5.2.5.2e	<titledpara>	
Individual wire identification	5-5.2.5.2f	<titledpara>	
WIRING SYSTEM COMPONENT REPAIR TOOL LIST WP	5-5.2.5.3	<comprelistwp>	
Introduction	5-5.2.5.1	<intro>	
Component repair tool list	5-5.2.5.3	<comprelist>	
AIRCRAFT SPECIFIC WIRING SYSTEMS REPAIR KIT WP	5-5.2.5.4	<reprkitwp>	
Introduction	5-5.2.5.1	<intro>	
Repair tool kit parts list	5-5.2.5.4	<reprkitlist>	
WIRE TYPE LIST WP	5-5.2.5.5	<wtypelistwp>	
Introduction	5-5.2.5.1	<intro>	
Wire type list	5-5.2.5.5	<wtypelist>	
AIRCRAFT SPECIFIC REPAIR TOOLS WP	5-5.2.5.6	<reptoolwp>	
Introduction	5-5.2.5.1	<intro>	
General description	5-5.2.5.6a	<intro>	
Repair procedures	5-5.2.5.6b	<maintproc>	
Adjustments	5-5.2.5.6c	<maintproc>	
Inspection	5-5.2.5.6d	<maintproc>	
Additional repair data	5-5.2.5.6e	<maintproc>	
WIRING SYSTEM CONNECTOR COMPONENT REPAIR WP	5-5.2.5.7	<wcomprewp>	
Introduction	5-5.2.5.1	<intro>	
Description	5-5.2.5.7	<wiringcompdesc>	
Maintenance procedures	5-5.2.5.7	<maintproc>	
AIRCRAFT CABLE ASSEMBLY PARTS DATA WP	5-5.2.5.8	<partswp>	
Introduction	5-5.2.5.1	<intro>	
Repair parts data	5-5.2.5.8	<partsdata>	

MIL-STD-3001-1A(AS) w/CHANGE 1

APPENDIX A

TABLE A-XII. AIRCRAFT POWER PLANT BUILD-UP MANUAL

TM CONTENTS	MIL-STD-3001-1 REFERENCE	ELEMENT NAME	REMARKS
TM FRONT MATTER AND SUPPORTING INFORMATION	1-B.5.3.1		
Title page	1-B.5.3.1.1	<titlepg>	
Numerical index of effective work packages/pages (A page)	1-B.5.3.1.2	<niewp>	
TPDR page	1-B.5.3.1.3	<tpdrpg>	
HMWS WP	1-B.5.3.1.4	<hmwswp>	
Alphabetical index WP	1-B.5.3.1.5	<alphaindxwp>	
Introduction WP	1-B.5.3.2.1.3.3	<introwp>	
Consolidated lists for technical directives, support equipment, materials and references WP	1-B.5.3.2.1.3.4	<consolistwp>	
WORK PACKAGE FRONT MATTER			
Title block	4-5.2.1	<titleblk>	
Work package information	4-5.2.2	<wpinfo>	
Reference material list	4-5.2.2.1	<reflist>	
Record of applicable technical directives	4-5.2.2.2	<ratd>	
Support equipment required list	4-5.2.2.3	<selist>	
Facilities required list	4-5.2.2.4	<faclist>	
Materials required list	4-5.2.2.5	<matlist>	
POWER PLANT BUILD-UP WORK PACKAGES	4-5.3.7		
General information WP	4-5.3.7.1	<geninfomaintwp>	
Quick engine change kit description WP	4-5.3.7.2	<qeckdescwp>	
Quick engine change assembly WP	4-5.3.7.3	<qecawp>	
Non-quick engine change assembly WPs	4-5.3.7.4	<nonqecawp>	
Additional power plant build-up WPs	4-5.3.7.5	<bldupwp>	
Illustrated parts breakdown data (as applicable for WPs listed above)	4-5.3.11	<ipbwp>	

MIL-STD-3001-1A(AS) w/CHANGE 1

APPENDIX A

TABLE A-XIII. PREOPERATIONAL AND TURNAROUND CHECKLIST CARD DECKS

TM CONTENTS	MIL-STD-3001-1 REFERENCE	ELEMENT NAME	REMARKS
TURNAROUND CHECKLIST REQUIREMENTS			
Aircraft	7-5.1.1.2	<turnchkst>	
Airborne mine countermeasure equipment	7-5.1.8.2	<turnchkst>	
Unmanned aerial vehicle	7-5.1.9.2	<turnchkst>	
PREOPERATIONAL CHECKLIST REQUIREMENTS			
Support equipment	7-5.1.4.1	<preopdk>	
Powered surface target	7-5.1.6.1	<preopdk>	
CHECKLIST FRONT MATTER			
Title and cover cards/Checklist title page	1-B.5.3.1 1-B.5.3.1.1.2, 1-B.5.3.1.1.3	<titlecd> <fmcl>	
INTRODUCTION AND APPLICATION STATEMENTS	7-5.2.3	<introaplcd>	
Introduction and application statements (turnaround checklist) card	7-5.2.3.1	<introaplcd>	
Introduction and application statements (preoperational checklist) card	7-5.2.3.2	<introaplcd>	
TASK CARDS (ALL CHECKLIST CARD DECKS)	7-5.2.19	<chkst>	

MIL-STD-3001-1A(AS) w/CHANGE 1

APPENDIX A

TABLE A-XIV. PHASED MAINTENANCE CARD DECKS

TM CONTENTS	MIL-STD-3001-1 REFERENCE	ELEMENT NAME	REMARKS
PHASED MAINTENANCE CARD DECK REQUIREMENTS	7-5.1.1.7	<phmaintdk>	
CARD DECK FRONT MATTER	1-B.5.3.1	<fmcds>	
Title card	1-B.5.3.1.1.2	<titlecd>	
List of effective cards	1-B.5.3.1.2.2	<lecds>	
TPDR card	1-B.5.3.1.3.2	<tpdracd>	
HMWS card	1-B.5.3.1.4.2	<hmwscard>	
INTRODUCTION AND APPLICATION STATEMENT	7-5.2.3	<introaplcd>	
Introduction and application statement card	7-5.2.3.4	<introaplcd>	
DECK CARDS			
Definitions	7-5.2.4	<defcd>	
Abbreviations, index, and checkflight requirements	7-5.2.10	<abindxcd>	
Special tools/support equipment lists	7-5.2.11	<secd>	
Consumable maintenance materials list	7-5.2.12	<consumcd>	
Replacement parts list	7-5.2.13	<rplcd>	
Work area or zone	7-5.2.14	<wrkareacd>	
		<zonecd>	
Zone title and description	7-5.2.15	<zonetltd>	
Zonal inspection criteria	7-5.2.16	<zoneinspcd>	
Access panels	7-5.2.17	<accpnlcd>	
Antenna location	7-5.2.18	<antcd>	
PHASE PACKAGE SUPPLEMENT			
Cover card	1-B.5.3.1.1.2		
Phase sequence control cards	7-5.2.20	<phscd>	
Task cards	7-5.2.22	<tskcd>	
Illustrations	7-5.2.23	<supported>	
QA	7-5.2.24	<qacd>	

MIL-STD-3001-1A(AS) w/CHANGE 1

APPENDIX A

TABLE A-XV. PERIODIC MAINTENANCE INFORMATION CARD DECKS

TM CONTENTS	MIL-STD-3001-1 REFERENCE	ELEMENT NAME	REMARKS
PERIODIC MAINTENANCE INFORMATION CARD SET	7-5.1	<pmrcset>	
Aircraft	7-5.1.1.1	<pmidk>	
Airborne armament equipment (AAE)	7-5.1.3.1	<pmidk>	
Airborne mine countermeasure equipment (AMCM)	7-5.1.8.1	<pmidk>	
Unmanned aerial vehicle (UAV)	7-5.1.9.1	<pmidk>	
CARD DECK FRONT MATTER	1-B.5.3.1	<fmcds>	
Title card	1-B.5.3.1.1.2	<titlecd>	
List of effective cards	1-B.5.3.1.2.2	<lecds>	
TPDR card	1-B.5.3.1.3.2	<tpdrcard>	
HMWS card	1-B.5.3.1.4.2	<hmwscard>	
INTRODUCTION	7-5.2.2		
Introduction (aircraft and AAE)	7-5.2.2.1	<introc>	
Introduction (AMCM and UAV)	7-5.2.2.2	<introc>	
PERIODIC MAINTENANCE INFORMATION DECK CARDS			
Removal/replacement schedule and special tracking requirements	7-5.2.5	<rrschtrkcd>	
Inspection requirements	7-5.2.6	<inspindcd>	
Conditional inspection listing (aircraft, AMCM, UAV only)	7-5.2.7	<condinsped>	
Phase change implementation (aircraft only)	7-5.2.8	<phchgcd>	

MIL-STD-3001-1A(AS) w/CHANGE 1

APPENDIX A

TABLE A-XVI. QUICK ENGINE CHANGE (QEC) PERIODIC MAINTENANCE REQUIREMENTS CARD DECKS

TM CONTENTS	MIL-STD-3001-1 REFERENCE	ELEMENT NAME	REMARKS
QUICK ENGINE CHANGE ASSEMBLY CARD SET	7-5.1.2	<qecaset>	
CARD DECK FRONT MATTER	1-B.5.3.1	<fmcds>	
Title card (PMRC)	1-B.5.3.1.1.2	<titlecd>	
List of effective cards	1-B.5.3.1.2.2	<lecds>	
TPDR card	1-B.5.3.1.3.2	<tpdrcard>	
HMWS card	1-B.5.3.1.4.2	<hmwscard>	
INTRODUCTION AND APPLICATION STATEMENT	7-5.2.3	<introaplcd>	
Introduction and application statement card	7-5.2.3.5	<introaplcd>	
DECK CARDS			
Definitions	7-5.2.4	<defcd>	
Abbreviations and index	7-5.2.9	<abindxcd>	
Special tools/support equipment list	7-5.2.11	<secd>	
Consumable maintenance material list	7-5.2.12	<consumcd>	
Replacement parts list	7-5.2.13	<rplcd>	
Work area	7-5.2.14	<wrkareacd>	
QECA sequence control	7-5.2.21	<qecacd>	
Tasks	7-5.2.22	<tskcd>	
Illustration	7-5.2.23	<supported>	
QA	7-5.2.24	<qacd>	
QEC cover	1-B.5.3.1.1.2	<sysnomen>	
QEC task	7-5.2.22	<tskcd>	
QEC illustration	7-5.2.23	<supported>	

MIL-STD-3001-1A(AS) w/CHANGE 1

APPENDIX A

TABLE A-XVII. POWERED SURFACE TARGET (PST) PERIODIC MAINTENANCE REQUIREMENTS CARD DECKS

TM CONTENTS	MIL-STD-3001-1 REFERENCE	ELEMENT NAME	REMARKS
POWERED SURFACE TARGET (PST) CARD SET Periodic Maintenance Requirements Card Deck Requirements	7-5.1.6 7-5.1.6.2	<pstset> <pmrkd>	
CARD DECK FRONT MATTER Title card (PMIC) List of effective cards TPDR card HMWS card	1-B.5.3.1 1-B.5.3.1.1.2 1-B.5.3.1.2.2 1-B.5.3.1.3.2 1-B.5.3.1.4.2	<fmcds> <titlecd> <lecds> <tpdrcard> <hmwscard>	
INTRODUCTION AND APPLICATION STATEMENT Introduction and application statement card	7-5.2.3 7-5.2.3.12	<introaplcd> <introaplcd>	
DECK CARDS Definitions Abbreviations and index Special tools/support equipment list Consumable maintenance material list Replacement parts list Work area or zone Access panel Antenna location Tasks (days, hours, events) Illustration QA	7-5.2.4 7-5.2.9 7-5.2.11 7-5.2.12 7-5.2.13 7-5.2.14 7-5.2.17 7-5.2.18 7-5.2.22 7-5.2.23 7-5.2.24	<defcd> <abindxcd> <secd> <consumcd> <rplcd> <wrkareacd> <zonecd> <accpnlcd> <antcd> <tskcd> <supported> <qacd>	

MIL-STD-3001-1A(AS) w/CHANGE 1

APPENDIX A

TABLE A-XVIII. AVIATION LIFE SUPPORT SYSTEMS (ALSS) PERIODIC MAINTENANCE REQUIREMENTS CARD DECKS

TM CONTENTS	MIL-STD-3001-1 REFERENCE	ELEMENT NAME	REMARKS
AVIATION LIFE SUPPORT SYSTEMS (ALSS) CARD SET	7-5.1.7	<alsset>	
Periodic Maintenance Requirements Card Deck Requirements	7-5.1.7.1	<pmrdk>	
CARD DECK FRONT MATTER	1-B.5.3.1	<fmcds>	
Title card	1-B.5.3.1.1.2	<titlecd>	
List of effective cards	1-B.5.3.1.2.2	<lecds>	
TPDR card	1-B.5.3.1.3.2	<tpdracd>	
HMWS card	1-B.5.3.1.4.2	<hmwscard>	
INTRODUCTION AND APPLICATION STATEMENT	7-5.2.3	<introaplcd>	
Introduction and application statement card	7-5.2.3.15	<introaplcd> <alssintroaplcd>	
DECK CARDS			
Definitions	7-5.2.4	<defcd>	
Abbreviations and index	7-5.2.9	<abindxcd>	
Special tools/support equipment list	7-5.2.11	<secd>	
Consumable maintenance material list	7-5.2.12	<consumcd>	
Replacement parts list	7-5.2.13	<rplcd>	
ALSS cover	1-B.5.3.1.1.2	<sysnomen>	
Tasks (days, hours)	7-5.2.22	<tskcd>	
Illustration	7-5.2.23	<supported>	
QA	7-5.2.24	<qacd>	

MIL-STD-3001-1A(AS) w/CHANGE 1

APPENDIX A

TABLE A-XIX. AIRCRAFT DAILY, SPECIAL, PRESERVATION, AND CONDITIONAL CARD DECKS

TM CONTENTS	MIL-STD-3001-1 REFERENCE	ELEMENT NAME	REMARKS
DAILY INSPECTION OR DAILY INSPECTION/ SERVICING REQUIREMENTS	7-5.1.1.3	<dayinspdk>	
SPECIAL INSPECTION REQUIREMENTS	7-5.1.1.4	<spinspdk>	
PRESERVATION/DEPRESERVATION REQUIREMENTS	7-5.1.1.5	<presdk>	
CONDITIONAL INSPECTION REQUIREMENTS	7-5.1.1.6	<condck>	
CARD DECK FRONT MATTER	1-B.5.3.1	<fmcds>	
Title card	1-B.5.3.1.1.2	<titlecd>	
List of effective cards	1-B.5.3.1.2.2	<lecds>	
TPDR card	1-B.5.3.1.3.2	<tpdrcard>	
HMWS card	1-B.5.3.1.4.2	<hmwscard>	
INTRODUCTION AND APPLICATION STATEMENT	7-5.2.3	<introaplcd>	
Introduction and application statement card	7-5.2.3.3	<introaplcd>	
DECK CARDS			
Definitions	7-5.2.4	<defcd>	
Abbreviations and index	7-5.2.9	<abindxcd>	
Special tools/support equipment list	7-5.2.11	<secd>	
Consumable maintenance material list	7-5.2.12	<consumcd>	
Replacement parts list	7-5.2.13	<rplcd>	
Work area or zone	7-5.2.14	<wrkareacd>	
Zone title and description (except daily card deck)	7-5.2.15	<zonetltd>	
Zonal inspection criteria (except daily card deck)	7-5.2.16	<zoneinspcd>	
Access panel	7-5.2.17	<accpnlcd>	
Antenna location (except daily card deck)	7-5.2.18	<antcd>	
Tasks (daily, special (day, hour, event), preservation, depreservation, and conditional)	7-5.2.22	<tskcd>	
Aircraft service period adjustment (ASPA) (special inspection card deck only)	7-5.1.1.4f	<tskcd>	
Illustration	7-5.2.23	<supported>	
QA	7-5.2.24	<qacd>	

MIL-STD-3001-1A(AS) w/CHANGE 1

APPENDIX A

TABLE A-XX. AAE OR SPECIAL STORES DAILY/SPECIAL CARD DECKS

TM CONTENTS	MIL-STD-3001-1 REFERENCE	ELEMENT NAME	REMARKS
DAILY/SPECIAL MAINTENANCE REQUIREMENTS	7-5.1.3.2	<dayinspdk>	
CARD DECK FRONT MATTER	1-B.5.3.1	<fmcds>	
Title card	1-B.5.3.1.1.2	<titlecd>	
List of effective cards	1-B.5.3.1.2.2	<lecds>	
TPDR card	1-B.5.3.1.3.2	<tpdrcard>	
HMWS card	1-B.5.3.1.4.2	<hmwscard>	
INTRODUCTION AND APPLICATION STATEMENT	7-5.2.3	<introaplcd>	
Introduction and application statement card	7-5.2.3.6	<introaplcd>	
DECK CARDS			
Definitions	7-5.2.4	<defcd>	
Abbreviations and index	7-5.2.9	<abindxcd>	
Special tools/support equipment list	7-5.2.11	<secd>	
Consumable maintenance material list	7-5.2.12	<consumcd>	
Replacement parts list	7-5.2.13	<rplcd>	
Work area or zone	7-5.2.14	<wrkareacd>	
		<zonecd>	
Tasks (daily, special (day, hour, event))	7-5.2.22	<tskcd>	
Illustration	7-5.2.23	<supported>	
QA	7-5.2.24	<qacd>	

MIL-STD-3001-1A(AS) w/CHANGE 1

APPENDIX A

TABLE A-XXI. TRAINING SYSTEMS (TS)/SUPPORT EQUIPMENT (SE)/AUTOMATIC TEST EQUIPMENT (ATE) DAILY, SPECIAL, PRESERVATION, AND CONDITIONAL CARD DECKS

TM CONTENTS	MIL-STD-3001-1 REFERENCE	ELEMENT NAME	REMARKS
DAILY INSPECTION OR DAILY INSPECTION/ SERVICING REQUIREMENTS	7-5.1.4.2	<dayinspdk>	
SPECIAL INSPECTION REQUIREMENTS	7-5.1.4.3	<spinspdk>	
PRESERVATION/DEPRESERVATION REQUIREMENTS	7-5.1.4.4	<presdk>	
CONDITIONAL INSPECTIONS REQUIREMENTS	7-5.1.4.5	<condck>	
CARD DECK FRONT MATTER	1-B.5.3.1	<fmcds>	
Title card	1-B.5.3.1.1.2	<titlecd>	
List of effective cards	1-B.5.3.1.2.2	<lecds>	
TPDR card	1-B.5.3.1.3.2	<tpdrcard>	
HMWS card	1-B.5.3.1.4.2	<hmwscard>	
INTRODUCTION AND APPLICATION STATEMENT	7-5.2.3	<introaplcd>	
Introduction and application statement card	7-5.2.3.7, 7-5.2.3.8	<introaplcd>	
DECK CARDS			
Definitions	7-5.2.4	<defcd>	
Abbreviations and index	7-5.2.9	<abindxcd>	
Special tools/support equipment list	7-5.2.11	<secd>	
Consumable maintenance material list	7-5.2.12	<consumcd>	
Replacement parts list	7-5.2.13	<rplcd>	
Work area or zone	7-5.2.14	<wrkareacd>	
Access panel	7-5.2.17	<accpnlcd>	
Antenna location	7-5.2.18	<antcd>	
Tasks (daily, special (day, start), preservation, depreservation, conditional)	7-5.2.22	<tskcd>	
Illustration	7-5.2.23	<supportedcd>	
QA	7-5.2.24	<qacd>	

MIL-STD-3001-1A(AS) w/CHANGE 1

APPENDIX A

TABLE A-XXII. AIRBORNE MINE COUNTERMEASURES (AMCM) DAILY AND UNMANNED AERIAL VEHICLE (UAV) DAILY INSPECT/DAILY INSPECT AND SERVICING CARD DECKS

TM CONTENTS	MIL-STD-3001-1 REFERENCE	ELEMENT NAME	REMARKS
DAILY, DAILY INSPECT/DAILY INSPECT AND SERVICING REQUIREMENTS AMCM daily requirements UAV daily inspection/daily inspection/servicing requirements	7-5.1.8.3 7-5.1.9.3	<dayinspdk> <dayinspdk>	
CARD DECK FRONT MATTER Title card List of effective cards TPDR card HMWS card	1-B.5.3.1 1-B.5.3.1.1.2 1-B.5.3.1.2.2 1-B.5.3.1.3.2 1-B.5.3.1.4.2	<fmcds> <titlecd> <lecds> <tpdrcard> <hmwscard>	
INTRODUCTION AND APPLICATION STATEMENT AMCM or UAV daily card deck	7-5.2.3 7-5.2.3.13	<introaplcd> <introaplcd>	
DECK CARDS Definitions Abbreviations and index Special tools/support equipment list Consumable maintenance material list Replacement parts list Access panel Antenna location Tasks Illustration QA	7-5.2.4 7-5.2.9 7-5.2.11 7-5.2.12 7-5.2.13 7-5.2.17 7-5.2.18 7-5.2.22 7-5.2.23 7-5.2.24	<defcd> <abindxcd> <secd> <consumcd> <rplcd> <accpnlcd> <antcd> <tskcd> <supportedcd> <qacd>	

MIL-STD-3001-1A(AS) w/CHANGE 1

APPENDIX A

TABLE A-XXIII. AMCM AND UAV SPECIAL, PRESERVATION, AND CONDITIONAL CARD DECKS

TM CONTENTS	MIL-STD-3001-1 REFERENCE	ELEMENT NAME	REMARKS
AMCM SPECIAL INSPECTION REQUIREMENTS	7-5.1.8.4	<spinspdk>	
AMCM PRESERVATION/DEPRESERVATION REQUIREMENTS	7-5.1.8.5	<presdk>	
AMCM CONDITIONAL INSPECTIONS REQUIREMENTS	7-5.1.8.6	<condck>	
UAV SPECIAL INSPECTION REQUIREMENTS	7-5.1.9.4	<spinspdk>	
UAV PRESERVATION/ DEPRESERVATION REQUIREMENTS	7-5.1.9.5	<presdk>	
UAV CONDITIONAL INSPECTIONS REQUIREMENTS	7-5.1.9.6	<condck>	
CARD DECK FRONT MATTER	1-B.5.3.1	<fmcds>	
Title card	1-B.5.3.1.1.2	<titlecd>	
List of effective cards	1-B.5.3.1.2.2	<lecds>	
TPDR card	1-B.5.3.1.3.2	<tpdrcard>	
HMWS card	1-B.5.3.1.4.2	<hmwscard>	
INTRODUCTION AND APPLICATION STATEMENT	7-5.2.3	<introapled>	
AMCM or UAV calendar or start/special/ preservation/ conditional card decks	7-5.2.3.14	<introapled>	
DECK CARDS			
Definitions	7-5.2.4	<defcd>	
Abbreviations and index	7-5.2.9	<abindxcd>	
Special tools/support equipment list	7-5.2.11	<secd>	
Consumable maintenance material list	7-5.2.12	<consumcd>	
Replacement parts list	7-5.2.13	<rplcd>	
Work area or zone	7-5.2.14	<wrkareacd>	
Access panel	7-5.2.17	<accpnlcd>	
Antenna location	7-5.2.18	<antcd>	
Tasks (calendar or start, special (day, hour, start), preservation, depreservation, conditional)	7-5.2.22	<tskcd>	
Illustration	7-5.2.23	<supportcd>	
QA	7-5.2.24	<qacd>	

MIL-STD-3001-1A(AS) w/CHANGE 1

APPENDIX A

TABLE A-XXIV. SE/ATE, AMCM AND UAV CALENDAR, HOUR, AND START CARD DECKS

TM CONTENTS	MIL-STD-3001-1 REFERENCE	ELEMENT NAME	REMARKS
SE/ATE CALENDAR/START INSPECTION REQUIREMENTS	7-5.1.4.6	<calendardk> <startdk>	
AMCM CALENDAR, HOUR, OR START MAINTENANCE REQUIREMENTS	7-5.1.8.7	<calendardk> <hourdk> <startdk>	
UAV CALENDAR, HOUR, OR START MAINTENANCE REQUIREMENTS	7-5.1.9.7	<calendardk> <hourdk> <startdk>	
CARD DECK FRONT MATTER	1-B.5.3.1	<fmcdds>	
Title card	1-B.5.3.1.1.2	<titlecd>	
List of effective cards	1-B.5.3.1.2.2	<lecds>	
TPDR card	1-B.5.3.1.3.2	<tpdracd>	
HMWS card	1-B.5.3.1.4.2	<hmwscard>	
INTRODUCTION AND APPLICATION STATEMENT	7-5.2.3	<introaplcd>	
SE/ATE calendar or start/special/preservation/ conditional card decks	7-5.2.3.7	<introaplcd>	
Aircraft peculiar support equipment (PSE) maintenance requirements card deck	7-5.2.3.8	<introaplcd>	
AMCM or UAV calendar or start/special/preservation/ conditional card decks	7-5.2.3.14	<introaplcd>	
DECK CARDS			
Definitions	7-5.2.4	<defcd>	
Abbreviations and index	7-5.2.9	<abindxcd>	
Special tools/support equipment list	7-5.2.11	<secd>	
Consumable maintenance material list	7-5.2.12	<consumcd>	
Replacement parts list	7-5.2.13	<rplcd>	
Work area or zone	7-5.2.14	<wrkareacd>	
Access panel	7-5.2.17	<accpnlcd>	
Tasks (days, hours, start, calendar)	7-5.2.22	<tskcd>	
Illustration	7-5.2.23	<supportcd>	
QA	7-5.2.24	<qacd>	

MIL-STD-3001-1A(AS) w/CHANGE 1

APPENDIX A

TABLE A-XXV. PAT PRELAUNCH AND POST LAUNCH/SERVICING CARD DECKS

TM CONTENTS	MIL-STD-3001-1 REFERENCE	ELEMENT NAME	REMARKS
PAT PRELAUNCH REQUIREMENTS	7-5.1.5.2	<prelnchdk>	
PAT POSTLAUNCH/SERVICING REQUIREMENTS	7-5.1.5.3	<postlnchdk>	
CARD DECK FRONT MATTER	1-B.5.3.1	<fmcds>	
Title card	1-B.5.3.1.1.2	<titlecd>	
List of effective cards	1-B.5.3.1.2.2	<lecds>	
TPDR card	1-B.5.3.1.3.2	<tpdrcard>	
HMWS card	1-B.5.3.1.4.2	<hmwscard>	
INTRODUCTION AND APPLICATION STATEMENT	7-5.2.3	<introaplcd>	
Powered aerial target (PAT) prelaunch card deck	7-5.2.3.10	<introaplcd>	
Powered aerial target (PAT) postlaunch card deck	7-5.2.3.11	<introaplcd>	
DECK CARDS			
Definitions	7-5.2.4	<defcd>	
Abbreviations and index	7-5.2.9	<abindxcd>	
Special tools/support equipment list	7-5.2.11	<secd>	
Consumable maintenance material (postlaunch/ servicing only)	7-5.2.12	<consumcd>	
Replacement parts list (postlaunch/servicing only)	7-5.2.13	<rplcd>	
Work area or zone	7-5.2.14	<wrkareacd>	
		<zonecd>	
Access panel	7-5.2.17	<accpnlcd>	
Antenna location	7-5.2.18	<antcd>	
Tasks	7-5.2.22	<tskcd>	
Illustration	7-5.2.23	<supported>	
QA	7-5.2.24	<qacd>	

MIL-STD-3001-1A(AS) w/CHANGE 1

APPENDIX A

TABLE A-XXVI. POWERED AERIAL TARGET (PAT) ACCEPTANCE/INITIAL BUILDUP CARD DECKS

TM CONTENTS	MIL-STD-3001-1 REFERENCE	ELEMENT NAME	REMARKS
ACCEPTANCE/INITIAL BUILDUP REQUIREMENTS	7-5.1.5.1	<acptbldupdk>	
CARD DECK FRONT MATTER	1-B.5.3.1	<fmcds>	
Title card	1-B.5.3.1.1.2	<titlecd>	
List of effective cards	1-B.5.3.1.2.2	<lecds>	
TPDR card	1-B.5.3.1.3.2	<tpdrcard>	
HMWS card	1-B.5.3.1.4.2	<hmwscard>	
INTRODUCTION AND APPLICATION STATEMENT	7-5.2.3	<introaplcd>	
Powered aerial target (PAT) acceptance/initial buildup card deck	7-5.2.3.9	<introaplcd>	
DECK CARDS			
Access panel	7-5.2.17	<accpnlcd>	
Antenna location	7-5.2.18	<antcd>	
Tasks	7-5.2.22	<tskcd>	
Illustration	7-5.2.23	<supported>	
QA	7-5.2.24	<qacd>	

MIL-STD-3001-1A(AS) w/CHANGE 1

APPENDIX A

TABLE A-XXVII. ILLUSTRATED PARTS BREAKDOWN (IPB) MANUAL

TM CONTENTS	MIL-STD-3001-1 REFERENCE	ELEMENT NAME	REMARKS
TM FRONT MATTER AND SUPPORTING INFORMATION	8-5.2	<ipbmanualfrnt>	
Title page	8-5.2.1	<titlepg>	
Numerical index of effective figures/pages (A page)	8-5.2.2	<niepage>	
TPDR page	8-5.2.3	<tpdrpg>	
Introduction WP	8-5.2.4	<introwp>	
Alphabetical index WP	8-5.3	<alphaindwp>	
Numerical index of part numbers WP	8-5.4	<partnoindwp>	
Numerical index of reference designations WP	8-5.5	<refdesindwp>	
GROUP ASSEMBLY PARTS LIST AND ASSOCIATED IPB FIGURES	8-5.6		
IPB Illustrations	8-5.6.1	<figure>	
IPB Group assembly parts lists	8-5.6.2	<gapl>	

MIL-STD-3001-1A(AS) w/CHANGE 1

APPENDIX A

TABLE A-XXVIII. OPERATION INSTRUCTIONS MANUAL (AERONAUTICAL EQUIPMENT, AIRBORNE WEAPONS/EQUIPMENT, AND SUPPORT EQUIPMENT)

TM CONTENTS	MIL-STD-3001-1 REFERENCE	ELEMENT NAME	REMARKS
TM FRONT MATTER AND SUPPORTING INFORMATION	1-B.5.3.1		
Title page	1-B.5.3.1.1	<titlepg>	
Numerical index of effective work packages/pages (A page)	1-B.5.3.1.2	<niewp>	
TPDR page	1-B.5.3.1.3	<tpdrpg>	
HMWS WP	1-B.5.3.1.4	<hmwswp>	
Alphabetical index WP	1-B.5.3.1.5	<alphaindxwp>	
Introduction WP	1-B.5.3.2.1.3.3	<introwp>	
Consolidated lists for technical directives, support equipment, materials and references WP	1-B.5.3.2.1.3.4	<consolistwp>	
WORK PACKAGE FRONT MATTER			
Title block	2-5.2.1	<titleblk>	
Work package information	2-5.2.2	<wpinfo>	
Reference material list	2-5.2.2.1	<reflist>	
Record of applicable technical directives	2-5.2.2.2	<ratd>	
Support equipment required list	2-5.2.2.3	<selist>	
Facilities required list	2-5.2.2.4	<faclist>	
Materials required list	2-5.2.2.5	<matlist>	
DESCRIPTION AND PRINCIPLES OF OPERATION WPs	2-5.2.4, 2-5.2.5		
Description WPs	2-5.2.4.2.2	<descwp>	
Introduction	2-5.2.4.2	<intro>	
System description	2-5.2.4.2.2	<sysdesc>	
Subsystem description	2-5.2.4.2.2	<sysdesc>	
Component description	2-5.2.4.2.2	<sysdesc>	
Controls and indicators descriptions	2-5.2.4.2.1.1	<ctrlinddesc>	
Programming software description work packages	2-5.2.4.2.4	<softwp>	
Introduction	2-5.2.4.2.4	<intro>	
Stimulus and measurement Programming	2-5.2.4.2.4	<stim-measdesc>	
Programming statements	2-5.2.4.2.4	<statedesc>	
Programming tests or self tests	2-5.2.4.2.4	<progtestdesc>	
Principles of operations WPs	2-5.2.5.2	<popwp>	
Introduction	2-5.2.5.2	<intro>	
System description	2-5.2.4.2.2	<sysdesc>	
Subsystem description	2-5.2.4.2.2	<sysdesc>	
Component description	2-5.2.4.2.2	<sysdesc>	
System principles of operation	2-5.2.5.2	<systhry>	
Subsystem principles of operation	2-5.2.5.2	<systhry>	
Component principles of operation	2-5.2.5.2	<systhry>	
SCHEMATIC DIAGRAM WORK PACKAGES	2-5.2.5.4	<schemwp>	
Introduction	2-5.2.5.4	<intro>	
OPERATION DATA	2-5.2.6		
Operating instruction WPs	2-5.2.6.1	<operwp>	
Introduction	2-5.2.6.1	<intro>	
Equipment preparation for use	2-5.2.6.1a	<prepuse>	
Pre-operational setup procedures	2-5.2.6.1b	<preop>	
Start-up procedures	2-5.2.6.1c	<startup>	
Controls and indicators descriptions	2-5.2.6.1d	<ctrlinddesc>	
Built-in-test or self-test procedures	2-5.2.6.1e	<bit-st-op>	
Operating procedures	2-5.2.6.1f	<op-proc>	
Emergency operation procedures	2-5.2.6.1g	<emerg-proc>	
Emergency shutdown procedures	2-5.2.6.1h	<emshut-proc>	
Post-operational shutdown procedures	2-5.2.6.1i	<post-op-proc>	
Software loading WPs	2-5.2.6.2	<softldwp>	

MIL-STD-3001-1A(AS) w/CHANGE 1

APPENDIX A

**TABLE A-XXIX. OPERATION AND MAINTENANCE INSTRUCTIONS WITH IPB MANUAL
(AERONAUTICAL EQUIPMENT, AIRBORNE WEAPONS/EQUIPMENT, AND SUPPORT EQUIPMENT)**

TM CONTENTS	MIL-STD-3001-1 REFERENCE	ELEMENT NAME	REMARKS
TM FRONT MATTER AND SUPPORTING INFORMATION	1-B.5.3.1		
Title page	1-B.5.3.1.1	<titlepg>	
Numerical index of effective work packages/pages (A page)	1-B.5.3.1.2	<niewp>	
TPDR page	1-B.5.3.1.3	<tpdrpg>	
HMWS WP	1-B.5.3.1.4	<hmwswp>	
Alphabetical index WP	1-B.5.3.1.5	<alphaindwp>	
Numerical index of part numbers work package	1-B.5.3.2.1.3.1	<partnoindwp>	
Numerical index of reference designations work package	1-B.5.3.2.1.3.2	<refdesindwp>	
Introduction WP	1-B.5.3.2.1.3.3	<introwp>	
Consolidated lists for technical directives, support equipment, materials and references WP	1-B.5.3.2.1.3.4	<consolistwp>	
WORK PACKAGE FRONT MATTER			
Title block	2-5.2.1	<titleblk>	
Work package information	2-5.2.2	<wpinfo>	
Reference material list	2-5.2.2.1	<reflist>	
Record of applicable technical directives	2-5.2.2.2	<ratd>	
Support equipment required list	4-5.2.2.3	<selist>	
Facilities required list	4-5.2.2.4	<faclist>	
Materials required list	4-5.2.2.5	<matlist>	
DESCRIPTION AND PRINCIPLES OF OPERATION WPs	2-5.2.4, 2-5.2.5		
Description WPs	2-5.2.4.2.2	<descwp>	
Introduction	2-5.2.4.2	<intro>	
System description	2-5.2.4.2.2	<sysdesc>	
Subsystem description	2-5.2.4.2.2	<sysdesc>	
Component description	2-5.2.4.2.2	<sysdesc>	
Controls and indicators descriptions	2-5.2.4.2.1.1	<ctrlinddesc>	
Programming software description work packages	2-5.2.4.2.4	<softwp>	
Introduction	2-5.2.4.2.4	<intro>	
Stimulus and measurement Programming	2-5.2.4.2.4	<stim-measdesc>	
Programming statements	2-5.2.4.2.4	<statedesc>	
Programming tests or self tests	2-5.2.4.2.4	<progtestdesc>	
Principles of operations WPs	2-5.2.5.2	<popwp>	
Introduction	2-5.2.5.2	<intro>	
System description	2-5.2.4.2.2	<sysdesc>	
Subsystem description	2-5.2.4.2.2	<sysdesc>	
Component description	2-5.2.4.2.2	<sysdesc>	
System principles of operation	2-5.2.5.2	<systhry>	
SCHEMATIC DIAGRAM WORK PACKAGES	2-5.2.5.4, 3-5.3.4.6.1	<schemwp>	
Introduction	2-5.2.5.4	<intro>	
OPERATION DATA	2-5.2.6		
Operating instruction WPs	2-5.2.6.1	<operwp>	
Introduction	2-5.2.6.1	<intro>	
Equipment preparation for use	2-5.2.6.1a	<prepuse>	
Pre-operational setup procedures	2-5.2.6.1b	<preop>	
Start-up procedures	2-5.2.6.1c	<startup>	
Controls and indicators descriptions	2-5.2.6.1d	<ctrlinddesc>	
Built-in-test or self-test procedures	2-5.2.6.1e	<bit-st-op>	
Operating procedures	2-5.2.6.1f	<op-proc>	

MIL-STD-3001-1A(AS) w/CHANGE 1

APPENDIX A

**TABLE A-XXIX. OPERATION AND MAINTENANCE INSTRUCTIONS WITH IPB MANUAL
(AERONAUTICAL EQUIPMENT, AIRBORNE WEAPONS/EQUIPMENT, AND SUPPORT EQUIPMENT)**

TM CONTENTS	MIL-STD-3001-1 REFERENCE	ELEMENT NAME	REMARKS
Emergency operation Emergency shutdown procedures Post-operational shutdown procedures Software loading WPs	2-5.2.6.1g 2-5.2.6.1h 2-5.2.6.1i 2-5.2.6.2	<emerg-proc> <emshut-proc> <post-op-proc> <softldwp>	
TESTING AND TROUBLESHOOTING DATA	3-5.1, 3-5.1.3, 3-5.2		
Testing and troubleshooting WPs	3-5.3.5		
Testing WPs	3-5.3.4.6.3	<opchkwp>	
Introduction	3-5.3.4.6.3a	<intro>	
General procedures and precautions	3-5.3.4.6.3b	<genproc>	
Pretest setup procedures	3-5.3.4.6.3c	<pretest>	
Testing procedures	3-5.3.4.6.3d	<opchk>	
Post-testing shutdown procedures	3-5.3.4.6.3e	<shutdown> <emergshtdn>	
Troubleshooting WPs	3-5.3.4.6.4	<trblshtwp>	
Introduction	3-5.3.4.6.4a	<intro>	
General procedures and precautions	3-5.3.4.6.4b	<genproc>	
Troubleshooting procedures	3-5.3.4.6.4c	<trblsht>	
Post-testing shutdown procedures	3-5.3.4.6.4d	<shutdown> <emergshtdn>	
Combined testing and troubleshooting WPs	3-5.3.4.6.5	<tst-trblwp>	
Introduction	3-5.3.4.6.5a	<intro>	
General procedures and precautions	3-5.3.4.6.5b	<genproc>	
Pretest setup procedures	3-5.3.4.6.5c	<pretest>	
Testing and troubleshooting procedures	3-5.3.4.6.5d	<opck-trblproc>	
Post-testing shutdown procedures	3-5.3.4.6.5e	<shutdown> <emergshtdn>	
MAINTENANCE INFORMATION WITH IPB	4-5.3		
Maintenance work packages	4-5.3.1	<maintwp>	
Introduction	4-5.3	<intro>	
Maintenance tasks	4-5.3.1.1		
Preparation for use and assembly	4-5.3.1.1a, 4-5.3.1.1.2	<prepuse>	
Handling	4-5.3.1.1b, 4-5.3.1.1.3	<handling>	
Stowage	4-5.3.1.1c	<stow>	
Removal	4-5.3.1.1d, 4-5.3.1.1.4	<remove>	
Disassembly	4-5.3.1.1e, 4-5.3.1.1.5	<dissam>	
Cleaning and corrosion control	4-5.3.1.1f, 4-5.3.1.1.6	<clncorr>	
Inspection	4-5.3.1.1g, 4-5.3.1.1.7	<insp>	
Service	4-5.3.1.1h	<service>	
Repair	4-5.3.1.1i, 4-5.3.1.1.8	<repair>	
Alignment	4-5.3.1.1j	<align>	
Painting	4-5.3.1.1k	<paint>	
Lubrication	4-5.3.1.1l	<lube>	
Assembly	4-5.3.1.1m, 4-5.3.1.1.9	<assem>	
Test and inspection	4-5.3.1.1n,	<test-inspect>	

MIL-STD-3001-1A(AS) w/CHANGE 1

APPENDIX A

**TABLE A-XXIX. OPERATION AND MAINTENANCE INSTRUCTIONS WITH IPB MANUAL
(AERONAUTICAL EQUIPMENT, AIRBORNE WEAPONS/EQUIPMENT, AND SUPPORT EQUIPMENT)**

TM CONTENTS	MIL-STD-3001-1 REFERENCE	ELEMENT NAME	REMARKS
Installation	4-5.3.1.1.10 4-5.3.1.1o, 4-5.1.1.1.11	<install>	
Rigging	4-5.3.1.1p	<rig>	
Adjustment	4-5.3.1.1q	<adjust>	
Calibration	4-5.3.1.1r, 4-5.3.1.1.12	<calibrate>	
Preparation for storage or shipment	4-5.3.1.1s, 4-5.3.1.1.13	<pss>	
Environmental conditioning	4-5.3.1.1t	<envircond>	
Safety information	4-5.3.1.1u, 4-5.3.1.1.14	<safe>	
Engine start and run-up	4-5.3.1.1v, 4-5.3.1.1.15	<engstart>	
Software loading	4-5.3.1.1w	<softload>	
Fabrication	4-5.3.1.1x, 4-5.3.1.1.16	<fabricate>	
Packing	4-5.3.1.1y	<packing>	
Unpacking	4-5.3.1.1z	<unpacking>	
Preservation	4-5.3.1.1aa	<preserve>	
Tracking	4-5.3.1.1ab	<track>	
Fueling	4-5.3.1.1ac	<fuel>	
Defueling	4-5.3.1.1ad	<defuel>	
Canning	4-5.3.1.1ae	<canning>	
Decanning	4-5.3.1.1af	<decanning>	
General maintenance procedures work package	4-5.3.2	<genmaintwp>	
Support equipment maintenance work package	4-5.3.5	<semaintwp>	
Local manufacturing and assembly work package	4-5.3.6	<locmfgwp>	
IPB data (as applicable for WPs listed above)	4-5.3.11	<ipbwp>	
Wiring/cabling diagram WP	4-5.3.12	<wirediawp>	
Wire run lists WP	4-5.3.13	<wirelistwp>	

MIL-STD-3001-1A(AS) w/CHANGE 1

APPENDIX A

TABLE A-XXX. OPERATION AND MAINTENANCE INSTRUCTIONS WITH IPB MANUAL (TRAINING SYSTEMS)

TM CONTENTS	MIL-STD-3001-1 REFERENCE	ELEMENT NAME	REMARKS
TM FRONT MATTER AND SUPPORTING INFORMATION	1-B.5.3.1		
Title page	1-B.5.3.1.1	<titlepg>	
Publication Number	1-B.5.3.1.1a	<tmidno>	
Former publication number	1-B.5.3.1.1b	<pretmidno>	
Publication date	1-B.5.3.1.1c	<pubdate>	
Change number and date	1-B.5.3.1.1d	<chgnum> <chgdate>	
Type of document	1-B.5.3.1.1e		
Publication title	1-B.5.3.1.1f	<prtitle>	
Level of maintenance	1-B.5.3.1.1f(1)	<maintlvl>	
Manual type (if applicable)	1-B.5.3.1.1f(2)	<manualtype>	
End item nomenclature	1-B.5.3.1.1f(3)	<sysnomen>	
Fleet readiness center notice	1-B.5.3.1.1g	<cfa>	
Supersedure notice	1-B.5.3.1.1h	<super>	
Cross reference notice	1-B.5.3.1.1i	<suppl>	
Continuation notice	1-B.5.3.1.1j	<continue>	
Interim rapid action change (IRAC)	1-B.5.3.1.1k	<irac>	
Distribution statement	1-B.5.3.1.1l	<distrib>	
Destruction notice	1-B.5.3.1.1m	<destr>	
Export control warning	1-B.5.3.1.1n	<export>	
Authority notice	1-B.5.3.1.1o	<authnote>	
National stock number	1-B.5.3.1.1p	<nsn>	
Title page (classified work package manuals)	1-B.5.3.1.1.1	<titlepg>	
Numerical index of effective work packages/pages (A page)	1-B.5.3.1.2	<niewp>	
TPDR page	1-B.5.3.1.3	<tpdrpg>	
HMWS WP	1-B.5.3.1.4	<hmwswp>	
Alphabetical index WP	1-B.5.3.1.5	<alphaindwp>	
Alphabetical index WP (multivolume manuals)	1-B.5.3.1.6	<alphaindwp>	
Supporting information	1-B.5.3.2		
Work package content	1-B.5.3.2.1		
Title block	1-B.5.3.2.1.1	<titleblk>	
Work package title	1-B.5.3.2.1.1a	<wptitle>	
Maintenance levels	1-B.5.3.2.1.1a(1)	<maintlvl>	
WP general title	1-B.5.3.2.1.1a(2)	<subject>	
End item nomenclature	1-B.5.3.2.1.1a(3)	<sysnomen>	
Effectivity notice	1-B.5.3.2.1.1b	<effect>	
Supersedure notice	1-B.5.3.2.1.1c	<super>	
Cross reference notice	1-B.5.3.2.1.1d	<suppl>	
Numerical index of part numbers WP	1-B.5.3.2.1.3.1	<partnoindwp>	
Numerical index of reference designations WP	1-B.5.3.2.1.3.2	<refdesindwp>	
Introduction WP	1-B.5.3.2.1.3.3	<introwp>	
Consolidated lists for technical directives, support equipment, materials and references WP	1-B.5.3.2.1.3.4	<consolistwp>	
Safety summary WP	1-B.5.3.2.1.3.6	<safewp>	
WORK PACKAGE FRONT MATTER			
Title block	2-5.2.1	<titleblk>	
Work package information	2-5.2.2	<wpinfo>	
Reference material list	2-5.2.2.1	<reflist>	
Record of applicable technical directives	2-5.2.2.2	<ratd>	
Support equipment required list	4-5.2.2.3	<selist>	

MIL-STD-3001-1A(AS) w/CHANGE 1

APPENDIX A

TABLE A-XXX. OPERATION AND MAINTENANCE INSTRUCTIONS WITH IPB MANUAL (TRAINING SYSTEMS)

TM CONTENTS	MIL-STD-3001-1 REFERENCE	ELEMENT NAME	REMARKS
Facilities required list	4-5.2.2.4	<faculist>	
Materials required list	4-5.2.2.5	<matlist>	
DESCRIPTION AND PRINCIPLES OF OPERATION WPs	2-5.2.4, 2-5.2.5		
Description WPs	2-5.2.4.2.2	<descwp>	
Introduction	2-5.2.4.2	<intro>	
System description	2-5.2.4.2.2	<sysdesc>	
Subsystem description	2-5.2.4.2.2	<sysdesc>	
Component description	2-5.2.4.2.2	<sysdesc>	
Controls and indicators descriptions	2-5.2.4.2.1.1	<ctrlinddesc>	
Programming software description WPs	2-5.2.4.2.4	<softwp>	
Introduction	2-5.2.4.2.4	<intro>	
Stimulus and measurement Programming	2-5.2.4.2.4	<stim-measdesc>	
Programming statements	2-5.2.4.2.4	<statedesc>	
Programming tests or self tests	2-5.2.4.2.4	<progtestdesc>	
Principles of operations WPs	2-5.2.5.2	<popwp>	
Introduction	2-5.2.5.2	<intro>	
System description	2-5.2.4.2.2	<sysdesc>	
Subsystem description	2-5.2.4.2.2	<sysdesc>	
Component description	2-5.2.4.2.2	<sysdesc>	
System principles of operation	2-5.2.5.2	<systhry>	
SCHEMATIC DIAGRAM WORK PACKAGES	2-5.2.5.4, 3-5.3.4.6.1	<schemwp>	
Introduction	2-5.2.5.4	<intro>	
OPERATION DATA	2-5.2.6		
Operating instruction WPs	2-5.2.6.1	<operwp>	
Introduction	2-5.2.6.1	<intro>	
Equipment preparation for use	2-5.2.6.1a	<prepuse>	
Pre-operational setup procedures	2-5.2.6.1b	<preop>	
Start-up procedures	2-5.2.6.1c	<startup>	
Controls and indicators descriptions	2-5.2.6.1d	<ctrlinddesc>	
Built-in-test or self-test procedures	2-5.2.6.1e	<bit-st-op>	
Operating procedures	2-5.2.6.1f	<op-proc>	
Emergency operation	2-5.2.6.1g	<emerg-proc>	
Emergency shutdown procedures	2-5.2.6.1h	<emshut-proc>	
Post-operational shutdown procedures	2-5.2.6.1i	<post-op-proc>	
Software loading WPs	2-5.2.6.2	<softldwp>	
TESTING AND TROUBLESHOOTING DATA	3-5.1, 3-5.1.3, 3-5.2		
Testing and troubleshooting WPs	3-5.3.5		
Troubleshooting WPs	3-5.3.4.6.4	<trblshtwp>	
Introduction	3-5.3.4.6.4a	<intro>	
General procedures and precautions	3-5.3.4.6.4b	<genproc>	
Troubleshooting procedures	3-5.3.4.6.4c	<trblsht>	
Post-testing shutdown procedures	3-5.3.4.6.4d	<shutdown> <emergshdn>	
MAINTENANCE INFORMATION WITH IPB	4-5.3		
Maintenance work packages	4-5.3.1	<maintwp>	
Introduction	4-5.3	<intro>	
Maintenance tasks	4-5.3.1.1		
Preparation for use and assembly	4-5.3.1.1a, 4-5.3.1.1.2	<prepuse>	
Handling	4-5.3.1.1b, 4-5.3.1.1.3	<handling>	

MIL-STD-3001-1A(AS) w/CHANGE 1

APPENDIX A

TABLE A-XXX. OPERATION AND MAINTENANCE INSTRUCTIONS WITH IPB MANUAL (TRAINING SYSTEMS)

TM CONTENTS	MIL-STD-3001-1 REFERENCE	ELEMENT NAME	REMARKS
Stowage	4-5.3.1.1c	<stow>	
Removal	4-5.3.1.1d, 4-5.3.1.1.4	<remove>	
Disassembly	4-5.3.1.1e, 4-5.3.1.1.5	<dissam>	
Cleaning and corrosion control	4-5.3.1.1f, 4-5.3.1.1.6	<clncorr>	
Inspection	4-5.3.1.1g, 4-5.3.1.1.7	<insp>	
Service	4-5.3.1.1h	<service>	
Repair	4-5.3.1.1i, 4-5.3.1.1.8	<repair>	
Alignment	4-5.3.1.1j	<align>	
Painting	4-5.3.1.1k	<paint>	
Lubrication	4-5.3.1.1l	<lube>	
Assembly	4-5.3.1.1m, 4-5.3.1.1.9	<assem>	
Test and inspection	4-5.3.1.1n, 4-5.3.1.1.10	<test-inspect>	
Installation	4-5.3.1.1o, 4-5.1.1.1.11	<install>	
Rigging	4-5.3.1.1p	<rig>	
Adjustment	4-5.3.1.1q	<adjust>	
Calibration	4-5.3.1.1r, 4-5.3.1.1.12	<calibrate>	
Preparation for storage or shipment	4-5.3.1.1s, 4-5.3.1.1.13	<pss>	
Environmental conditioning	4-5.3.1.1t	<envircond>	
Safety information	4-5.3.1.1u, 4-5.3.1.1.14	<safe>	
Software loading	4-5.3.1.1w	<softload>	
Packing	4-5.3.1.1y	<packing>	
Unpacking	4-5.3.1.1z	<unpacking>	
Preservation	4-5.3.1.1aa	<preserve>	
Tracking	4-5.3.1.1ab	<track>	
General maintenance procedures work package	4-5.3.2	<genmaintwp>	
Support equipment maintenance work package	4-5.3.5	<semaintwp>	
Local manufacturing and assembly work package	4-5.3.6	<locmfgwp>	
IPB data (as applicable for WPs listed above)	4-5.3.11	<ipbwp>	
Wiring/cabling diagram WP	4-5.3.12	<wirediawp>	
Wire run lists WP	4-5.3.13	<wirelistwp>	

MIL-STD-3001-1A(AS) w/CHANGE 1

APPENDIX A

TABLE -XXXI. MAINTENANCE INSTRUCTIONS WITH IPB MANUAL (AERONAUTICAL EQUIPMENT, AIRBORNE WEAPONS/EQUIPMENT, AND SUPPORT EQUIPMENT)

TM CONTENTS	MIL-STD-3001-1 REFERENCE	ELEMENT NAME	REMARKS
TM FRONT MATTER AND SUPPORTING INFORMATION Title page Numerical index of effective work packages/pages (A page) TPDR page HMWS WP Alphabetical index WP Numerical index of part numbers work package Numerical index of reference designations work package Introduction WP Consolidated lists for technical directives, support equipment, materials and references WP	1-B.5.3.1 1-B.5.3.1.1 1-B.5.3.1.2 1-B.5.3.1.3 1-B.5.3.1.4 1-B.5.3.1.5 1-B.5.3.2.1.3.1 1-B.5.3.2.1.3.2 1-B.5.3.2.1.3.3 1-B.5.3.2.1.3.4	<titlepg> <niewp> <tpdrpg> <hmwswp> <alphaindwp> <partnoindwp> <refdesindwp> <introwp> <consolistwp>	
WORK PACKAGE FRONT MATTER Title block Work package information Reference material list Record of applicable technical directives Support equipment required list Facilities required list Materials required list	4-5.2.1 4-5.2.2 4-5.2.2.1 4-5.2.2.2 4-5.2.2.3 4-5.2.2.4 4-5.2.2.5	<titleblk> <wpinfo> <reflist> <ratd> <selist> <faclist> <matlist>	
DESCRIPTION AND PRINCIPLES OF OPERATION WPs Description WPs Introduction System description Subsystem description Component description Controls and indicators descriptions Programming software description work packages Introduction Stimulus and measurement Programming Programming statements Programming tests or self tests Principles of operations WPs Introduction System description Subsystem description Component description Controls and indicators descriptions System principles of operation	2-5.2.4, 2-5.2.5 2-5.2.4.2.2 2-5.2.4.2 2-5.2.4.2.2 2-5.2.4.2.2 2-5.2.4.2.2 2-5.2.4.2.1.1 2-5.2.4.2.4 2-5.2.4.2.4 2-5.2.4.2.4 2-5.2.4.2.4 2-5.2.4.2.4 2-5.2.4.2.4 2-5.2.5.2 2-5.2.5.2 2-5.2.4.2.2 2-5.2.4.2.2 2-5.2.4.2.2 2-5.2.4.2.1.1 2-5.2.5.2	<descwp> <intro> <sysdesc> <sysdesc> <sysdesc> <ctrlinddesc> <softwp> <intro> <stim-measdesc> <statedesc> <progtestdesc> <popwp> <intro> <sysdesc> <sysdesc> <sysdesc> <ctrlinddesc> <systry>	
SCHEMATIC DIAGRAM WORK PACKAGES Introduction	2-5.2.5.4, 3-5.3.4.6.1 2-5.2.5.4	<schemwp> <intro>	
TESTING AND TROUBLESHOOTING DATA Testing and troubleshooting WPs Testing WPs Introduction General procedures and precautions Pretest setup procedures Testing procedures Post-testing shutdown procedures	3-5.1, 3-5.1.3, 3-5.2 3-5.3.5 3-5.3.4.6.3 3-5.3.4.6.3a 3-5.3.4.6.3b 3-5.3.4.6.3c 3-5.3.4.6.3d 3-5.3.4.6.3e	<opchkwp> <intro> <genproc> <pretest> <opchk> <shutdown>	

MIL-STD-3001-1A(AS) w/CHANGE 1

APPENDIX A

TABLE -XXXI. MAINTENANCE INSTRUCTIONS WITH IPB MANUAL (AERONAUTICAL EQUIPMENT, AIRBORNE WEAPONS/EQUIPMENT, AND SUPPORT EQUIPMENT)

TM CONTENTS	MIL-STD-3001-1 REFERENCE	ELEMENT NAME	REMARKS
Troubleshooting WPs	3-5.3.4.6.4	<emergshtdn>	
Introduction	3-5.3.4.6.4a	<trblshtwp>	
General procedures and precautions	3-5.3.4.6.4b	<intro>	
Troubleshooting procedures	3-5.3.4.6.4c	<genproc>	
Post-testing shutdown procedures	3-5.3.4.6.4d	<trblsht>	
Combined testing and troubleshooting WPs	3-5.3.4.6.5	<shutdown>	
Introduction	3-5.3.4.6.5a	<emergshtdn>	
General procedures and precautions	3-5.3.4.6.5b	<tst-trblwp>	
Pretest setup procedures	3-5.3.4.6.5c	<intro>	
Testing and troubleshooting procedures	3-5.3.4.6.5d	<genproc>	
Post-testing shutdown procedures	3-5.3.4.6.5e	<pretest>	
		<opck-trblproc>	
		<shutdown>	
		<emergshtdn>	
MAINTENANCE INFORMATION WITH IPB	4-5.3		
Maintenance work packages	4-5.3.1	<maintwp>	
Introduction	4-5.3	<intro>	
Maintenance tasks	4-5.3.1.1		
Preparation for use and assembly	4-5.3.1.1a,	<prepuse>	
	4-5.3.1.1.2		
Handling	4-5.3.1.1b,	<handling>	
	4-5.3.1.1.3		
Stowage	4-5.3.1.1c	<stow>	
Removal	4-5.3.1.1d,	<remove>	
	4-5.3.1.1.4		
Disassembly	4-5.3.1.1e,	<dissam>	
	4-5.3.1.1.5		
Cleaning and corrosion control	4-5.3.1.1f,	<clncorr>	
	4-5.3.1.1.6		
Inspection	4-5.3.1.1g,	<insp>	
	4-5.3.1.1.7		
Service	4-5.3.1.1h	<service>	
Repair	4-5.3.1.1i,	<repair>	
	4-5.3.1.1.8		
Alignment	4-5.3.1.1j	<align>	
Painting	4-5.3.1.1k	<paint>	
Lubrication	4-5.3.1.1l	<lube>	
Assembly	4-5.3.1.1m,	<assem>	
	4-5.3.1.1.9		
Test and inspection	4-5.3.1.1n,	<test-inspect>	
	4-5.3.1.1.10		
Installation	4-5.3.1.1o,	<install>	
	4-5.1.1.1.11		
Rigging	4-5.3.1.1p	<rig>	
Adjustment	4-5.3.1.1q	<adjust>	
Calibration	4-5.3.1.1r,	<calibrate>	
	4-5.3.1.1.12		
Preparation for storage or shipment	4-5.3.1.1s,	<pss>	
	4-5.3.1.1.13		
Environmental conditioning	4-5.3.1.1t	<envircond>	
Safety information	4-5.3.1.1u,	<safe>	
	4-5.3.1.1.14		
Engine start and run-up	4-5.3.1.1v,	<engstart>	

MIL-STD-3001-1A(AS) w/CHANGE 1

APPENDIX A

TABLE -XXXI. MAINTENANCE INSTRUCTIONS WITH IPB MANUAL (AERONAUTICAL EQUIPMENT, AIRBORNE WEAPONS/EQUIPMENT, AND SUPPORT EQUIPMENT)

TM CONTENTS	MIL-STD-3001-1 REFERENCE	ELEMENT NAME	REMARKS
Software loading	4-5.3.1.1.15		
Fabrication	4-5.3.1.1w	<softload>	
	4-5.3.1.1x,	<fabricate>	
	4-5.3.1.1.16		
Packing	4-5.3.1.1y	<packing>	
Unpacking	4-5.3.1.1z	<unpacking>	
Preservation	4-5.3.1.1aa	<preserve>	
Tracking	4-5.3.1.1ab	<track>	
Fueling	4-5.3.1.1ac	<fuel>	
Defueling	4-5.3.1.1ad	<defuel>	
Canning	4-5.3.1.1ae	<canning>	
Decanning	4-5.3.1.1af	<decanning>	
General maintenance procedures work package	4-5.3.2	<genmaintwp>	
Support equipment maintenance work package	4-5.3.5	<semaintwp>	
Local manufacturing and assembly work package	4-5.3.6	<locmfgwp>	
IPB data (as applicable for WPs listed above)	4-5.3.11	<ipbwp>	
Wiring/cabling diagram WP	4-5.3.12	<wirediawp>	
Wire run lists WP	4-5.3.13	<wirelistwp>	

MIL-STD-3001-1A(AS) w/CHANGE 1

APPENDIX A

TABLE A-XXXII. ENGINE INTERMEDIATE AND DEPOT MAINTENANCE MANUAL.

TM CONTENTS	MIL-STD-3001-1 REFERENCE	ELEMENT NAME	REMARKS
TM FRONT MATTER AND SUPPORTING INFORMATION	1-B.5.3.1		
Title page	1-B.5.3.1.1	<titlepg>	
Numerical index of effective work packages/pages (A page)	1-B.5.3.1.2	<niewp>	
TPDR page	1-B.5.3.1.3	<tpdrpg>	
HMWS WP	1-B.5.3.1.4	<hmwswp>	
Alphabetical index WP	1-B.5.3.1.5	<alphaindwp>	
Numerical index of part numbers work package	1-B.5.3.2.1.3.1	<partnoindwp>	
Numerical index of reference designations work package	1-B.5.3.2.1.3.2	<refdesindwp>	
Introduction WP	1-B.5.3.2.1.3.3	<introwp>	
Consolidated lists for technical directives, support equipment, materials and references WP	1-B.5.3.2.1.3.4	<consolistwp>	
Maintenance allocation WP (engine intermediate maintenance only)	1-B.5.3.2.1.3.5	<maintalwp>	
WORK PACKAGE FRONT MATTER			
Title block	4-5.2.1	<titleblk>	
Work package information	4-5.2.2	<wpinfo>	
Reference material list	4-5.2.2.1	<reflist>	
Record of applicable technical directives	4-5.2.2.2	<ratd>	
Support equipment required list	4-5.2.2.3	<selist>	
Facilities required list	4-5.2.2.4	<faclist>	
Materials required list	4-5.2.2.5	<matlist>	
DESCRIPTION WORK PACKAGES	2-5.2.3, 2-5.2.4		
Engine, engine systems, and engine component description WPs			
Engine description WP	2-5.2.4.2.3	<descwp>	
Introduction	2-5.2.4.2	<intro>	
Engine description	2-5.2.4.2.3	<sysdesc>	
Engine systems description WPs	2-5.2.4.2.3	<descwp>	
Introduction	2-5.2.4.2	<intro>	
Engine systems description	2-5.2.4.2.3	<sysdesc>	
Engine component description WPs	2-5.2.4.2.3	<descwp>	
Introduction	2-5.2.4.2	<intro>	
Engine component description	2-5.2.4.2.3	<sysdesc>	
SCHEMATIC DIAGRAM WORK PACKAGES	2-5.2.5.4	<schemwp>	
Introduction	2-5.2.5.4	<intro>	
ENGINE AND ENGINE SYSTEMS PRINCIPLES OF OPERATION WPs	2-5.2.5		
Engine principles of operation WP	2-5.2.5.3	<popwp>	
Introduction	2-5.2.5.3	<intro>	
Engine description	2-5.2.4.2.3	<sysdesc>	
Engine systems description	2-5.2.4.2.3	<sysdesc>	
Engine principles of operation	2-5.2.5.3	<systhry>	
Engine systems principles of operation WPs	2-5.2.5.3	<popwp>	
Introduction	2-5.2.5.3	<intro>	
Engine system description	2-5.2.4.2.3	<sysdesc>	
Component description	2-5.2.4.2.3	<sysdesc>	
Engine system principles of operation	2-5.2.5.3	<systhry>	
Component principles of operation	2-5.2.5.3	<systhry>	
Engine component principles of operation WPs	2-5.2.5.3	<popwp>	
Introduction	2-5.2.5.3	<intro>	
Component description	2-5.2.4.2.3	<sysdesc>	

MIL-STD-3001-1A(AS) w/CHANGE 1

APPENDIX A

TABLE A-XXXII. ENGINE INTERMEDIATE AND DEPOT MAINTENANCE MANUAL.

TM CONTENTS	MIL-STD-3001-1 REFERENCE	ELEMENT NAME	REMARKS
Component principles of operation	2-5.2.5.3	<systry>	
TESTING AND TROUBLESHOOTING WPs	3-5.1, 3-5.1.4, 3-5.3.3		
Engine testing and troubleshooting WPs	3-5.3.6		
Engine testing procedures WP	3-5.3.6.1	<engtestwp>	
Introduction	3-5.3.6.1a	<intro>	
General procedures and precautions	3-5.3.6.1b	<genproc>	
Standard charts and conversion tables	3-5.3.6.1c	<perfevaldata>	
Testing required after special repairs	3-5.3.6.1d	<specreptst>	
Test requirements	3-5.3.6.1e	<testreq>	
Engine inspection	3-5.3.6.1f	<enginspect>	
Abnormal conditions during operation	3-5.3.6.1g	<abnormcond>	
Engine operation under unusual conditions	3-5.3.6.1h	<unusualcond>	
Engine operating limits	3-5.3.6.1i	<oplimit>	
Engine start	3-5.3.6.1j	<engstart>	
Preparation for test	3-5.3.6.1k	<testprep>	
Engine test	3-5.3.6.1l	<engtest>	
Engine shutdown	3-5.3.6.1m	<shutdown>	
Engine post-test	3-5.3.6.1n	<postest>	
Engine troubleshooting WPs	3-5.3.6.2	<trblshtwp>	
Introduction	3-5.3.6.2a	<intro>	
General procedures and precautions	3-5.3.6.2b	<genproc>	
Troubleshooting procedures	3-5.3.6.2c	<trblsht>	
Post-operational shutdown procedures	3-5.3.6.2d	<shutdown>	
ENGINE MAINTENANCE WPs	4-5.3		
Maintenance work packages	4-5.3.1	<maintwp>	
Introduction	4-5.3	<intro>	
Maintenance tasks	4-5.3.1.1		
Preparation for use and assembly	4-5.3.1.1a, 4-5.3.1.1.2	<prepuse>	
Handling	4-5.3.1.1b, 4-5.3.1.1.3	<handling>	
Stowage	4-5.3.1.1c	<stow>	
Removal	4-5.3.1.1d, 4-5.3.1.1.4	<remove>	
Disassembly	4-5.3.1.1e, 4-5.3.1.1.5	<dissam>	
Cleaning and corrosion control	4-5.3.1.1f, 4-5.3.1.1.6	<clncorr>	
Inspection	4-5.3.1.1g, 4-5.3.1.1.7	<insp>	
Service	4-5.3.1.1h	<service>	
Repair	4-5.3.1.1i, 4-5.3.1.1.8	<repair>	
Alignment	4-5.3.1.1j	<align>	
Painting	4-5.3.1.1k	<paint>	
Lubrication	4-5.3.1.1l	<lube>	
Assembly	4-5.3.1.1m, 4-5.3.1.1.9	<assem>	
Test and inspection	4-5.3.1.1n, 4-5.3.1.1.10	<test-inspect>	
Installation	4-5.3.1.1o,	<install>	

MIL-STD-3001-1A(AS) w/CHANGE 1

APPENDIX A

TABLE A-XXXII. ENGINE INTERMEDIATE AND DEPOT MAINTENANCE MANUAL.

TM CONTENTS	MIL-STD-3001-1 REFERENCE	ELEMENT NAME	REMARKS
Rigging	4-5.1.1.1.11		
Adjustment	4-5.3.1.1p	<rig>	
Calibration	4-5.3.1.1q	<adjust>	
	4-5.3.1.1r,	<calibrate>	
Preparation for storage or shipment	4-5.3.1.1.12		
	4-5.3.1.1s,	<pss>	
Environmental conditioning	4-5.3.1.1.13		
Safety information	4-5.3.1.1t	<envircond>	
	4-5.3.1.1u,	<safe>	
Engine start and run-up	4-5.3.1.1.14		
	4-5.3.1.1v,	<engstart>	
Software loading	4-5.3.1.1.15		
Fabrication	4-5.3.1.1w	<softload>	
	4-5.3.1.1x,	<fabricate>	
	4-5.3.1.1.16		
Packing	4-5.3.1.1y	<packing>	
Unpacking	4-5.3.1.1z	<unpacking>	
Preservation	4-5.3.1.1aa	<preserve>	
Tracking	4-5.3.1.1ab	<track>	
Fueling	4-5.3.1.1ac	<fuel>	
Defueling	4-5.3.1.1ad	<defuel>	
Canning	4-5.3.1.1ae	<canning>	
Decanning	4-5.3.1.1af	<decanning>	
General maintenance procedures work package	4-5.3.2	<genmaintwp>	
Support equipment maintenance work package	4-5.3.5	<semaintwp>	
Local manufacturing and assembly work package	4-5.3.6	<locmfgwp>	
Preinduction and mandatory inspection WP	4-5.3.8	<preindinswp>	
External tubing, cabling and clamping WPs	4-5.3.9		
Numerical index WP	4-5.3.9.1	<compindwp>	
Bracket installation WP	4-5.3.9.2	<brktwp>	
External components WP	4-5.3.9.3	<extcompwp>	
External tubing, cabling and clamping installation WP	4-5.3.9.4	<extubwp>	
Critical clearances WP	4-5.3.9.5	<critclwp>	
IPB data (as applicable for WPs listed above)	4-5.3.11	<ipbwp>	
Wiring/cabling diagram WP	4-5.3.12	<wirediawp>	
Wire run lists WP	4-5.3.13	<wirelistwp>	

MIL-STD-3001-1A(AS) w/CHANGE 1

APPENDIX A

TABLE A-XXXIII. AIRCRAFT SYSTEMS AND EQUIPMENT MAINTENANCE IETMs.

TM CONTENTS	MIL-STD-3001-1 REFERENCE	ELEMENT NAME	REMARKS
FRONT MATTER AND SUPPORTING INFORMATION	1-C.5.3		
CD label and flyleaf data	1-C.5.3.1		
Title page	1-C.5.3.2	<titlepg>	
Revision summary data	1-C.5.3.3	<revision-summary-info>	
Table of contents	1-C.5.3.4		
How to use this IETM information	1-C.5.3.5	<how-to-use-etm>	
Acronyms and abbreviations list	1-C.5.3.6	<abbrevlist>	
Effectivity information	1-C.5.3.7	<consoleffectlist>	
Supporting information WPs	1-C.5.4	<supportinfo>	
Hazardous materials warning summary (HMWS) WP	1-C.5.4.1	<hmwswp>	
Consolidated numerical index of part numbers WP	1-C.5.4.2	<partnoindxwp>	
Consolidated numerical index of reference designations WP	1-C.5.4.3	<refdesindxwp>	
Historical record of applicable technical directives	1-C.5.4.4	<hratd>	
Consolidated list of support equipment required	1-C.5.4.5	<sereq>	
Consolidated list of materials required	1-C.5.4.6	<matreq>	
Consolidated list of reference material	1-C.5.4.7	<refmat>	
Maintenance allocation WP (engine intermediate maintenance only)	1-C.5.4.8	<maintalwp>	
<i>NOTE: As applicable, all work packages shall include work package title and setup information.</i>			
DESCRIPTION AND PRINCIPLES OF OPERATION DATA	2-5.1, 2-5.2.3		
DESCRIPTION WORK PACKAGES	2-5.2.4		
Aircraft general description work packages	2-5.2.4.1		
Introduction	2-5.2.4.1	<intro>	
Aircraft general description work package	2-5.2.4.1.1	<acdescwp>	
Aircraft description	2-5.2.4.1.1.1	<acdesc>	
Aircraft dimensions	2-5.2.4.1.1.2	<acdimm>	
Aircraft materials distribution	2-5.2.4.1.1.3	<acmats>	
Aircraft arrangement work package	2-5.2.4.1.2	<acarrgwp>	
Aircraft systems description work package	2-5.2.4.1.3	<acsysdescwp>	
Aircraft instrument panel location work package	2-5.2.4.1.4	<acpnlpwp>	
Danger areas and precautionary measures work package	2-5.2.4.1.5	<dangarwp>	
Aircraft stations work package	2-5.2.4.1.6	<acstawp>	
Aircraft dimensions work package	2-5.2.4.1.7	<acdimmwp>	
Aircraft access and inspection panels and provisions WP	2-5.2.4.1.8	<acacesswp>	
Aircraft external power source connections work package	2-5.2.4.1.9	<acextpwrwp>	
Aircraft system, subsystem, and component description WPs	2-5.2.4.2.1	<descwp>	
Introduction	2-5.2.4.2	<intro>	
System description	2-5.2.4.2.1	<sysdesc>	
Subsystem description	2-5.2.4.2.1	<sysdesc>	
Component description	2-5.2.4.2.1	<sysdesc>	
Controls and indicators descriptions	2-5.2.4.2.1.1	<ctrlinddesc>	
PROGRAMMING SOFTWARE DESCRIPTION WORK PACKAGES	2-5.2.4.2.4	<softwp>	
Introduction	2-5.2.4.2.4	<intro>	

MIL-STD-3001-1A(AS) w/CHANGE 1

APPENDIX A

TABLE A-XXXIII. AIRCRAFT SYSTEMS AND EQUIPMENT MAINTENANCE IETMs.

TM CONTENTS	MIL-STD-3001-1 REFERENCE	ELEMENT NAME	REMARKS
Stimulus and measurement programming	2-5.2.4.2.4	<stim-measdesc>	
Programming statements	2-5.2.4.2.4	<statedesc>	
Programming tests or self tests	2-5.2.4.2.4	<progtestdesc>	
PRINCIPLES OF OPERATION WORK PACKAGES	2-5.2.5		
Aircraft principles of operation work packages	2-5.2.5.1	<popwp>	
Introduction	2-5.2.5.1	<intro>	
System description	2-5.2.4.2.1	<sysdesc>	
System principles of operation	2-5.2.5.1	<systhry>	
Subsystem description	2-5.2.4.2.1	<sysdesc>	
Subsystem principles of operation	2-5.2.5.1	<systhry>	
Component description	2-5.2.4.2.1	<sysdesc>	
Component principles of operation	2-5.2.5.1	<systhry>	
SCHEMATIC DIAGRAM WORK PACKAGES	2-5.2.5.4,	<schemwp>	
	3-5.3.4.6.1		
Introduction	2-5.2.5.4	<intro>	
OPERATION INSTRUCTION WORK PACKAGES	2-5.2.6		
Operating instruction WPs	2-5.2.6.1	<operwp>	
Introduction	2-5.2.6.1	<intro>	
Equipment preparation for use	2-5.2.6.1a	<prepuse>	
Pre-operational setup procedures	2-5.2.6.1b	<preop>	
Start-up procedures	2-5.2.6.1c	<startup>	
Controls and indicators descriptions	2-5.2.6.1d	<ctrlinddesc>	
Built-in-test or self-test procedures	2-5.2.6.1e	<bit-st-op>	
Operating procedures	2-5.2.6.1f	<op-proc>	
Emergency operation	2-5.2.6.1g	<emerg-proc>	
Emergency shutdown procedures	2-5.2.6.1h	<emshut-proc>	
Post-operational shutdown procedures	2-5.2.6.1i	<post-op-proc>	
Software loading WPs	2-5.2.6.2	<softldwp>	
TESTING AND TROUBLESHOOTING DATA	3-5.1, 3-5.1.2,		
	3-5.2, 3-5.3.4		
Aircraft and aircraft systems testing and troubleshooting WPs	3-5.3.4		
Maintenance code listing WP	3-5.3.4.1	<maintcdwp>	
Fault indications WP	3-5.3.4.2	<fltindwp>	
Fault descriptor WP	3-5.3.4.3	<fltdescriptwp>	
Symbology WPs	3-5.3.4.4	<symwp>	
Fault isolation troubleshooting procedure WPs	3-5.3.4.5	<fitrblwp>	
Operational checkout WPs	3-5.3.4.6.3	<opchkwp>	
Introduction	3-5.3.4.6.3a	<intro>	
General procedures and precautions	3-5.3.4.6.3b	<genproc>	
Pretest setup procedures	3-5.3.4.6.3c	<pretest>	
Operational checkout procedures	3-5.3.4.6.3d	<opchk>	
Post-operational shutdown procedures	3-5.3.4.6.3e	<shutdown>	
Troubleshooting WPs	3-5.3.4.6.4	<trblshtwp>	
Introduction	3-5.3.4.6.4a	<intro>	
General procedures and precautions	3-5.3.4.6.4b	<genproc>	
Troubleshooting procedures	3-5.3.4.6.4c	<trblsht>	
Post-operational shutdown procedures	3-5.3.4.6.4d	<shutdown>	
Combined operational checkout and troubleshooting WPs	3-5.3.4.6.5	<emergshtdn>	
Introduction	3-5.3.4.6.5a	<tst-trblwp>	
General procedures and precautions	3-5.3.4.6.5b	<intro>	
		<genproc>	

MIL-STD-3001-1A(AS) w/CHANGE 1

APPENDIX A

TABLE A-XXXIII. AIRCRAFT SYSTEMS AND EQUIPMENT MAINTENANCE IETMs.

TM CONTENTS	MIL-STD-3001-1 REFERENCE	ELEMENT NAME	REMARKS
Pretest setup procedures	3-5.3.4.6.5c	<pretest>	
Operational checkout and troubleshooting procedures	3-5.3.4.6.5d	<opck-trblproc>	
Post-operational shutdown procedures	3-5.3.4.6.5e	<shutdown>	
Functional flow diagram WPs	3-5.3.4.7	<ffdiagwp>	
Functional flow diagrams	3-5.3.4.7, 3-5.3.4.7.1	<ffdiagram>	
MAINTENANCE INFORMATION WITH IPB	4-5.3		
Maintenance work packages	4-5.3.1	<maintwp>	
Introduction	4-5.3	<intro>	
Maintenance tasks	4-5.3.1.1		
Preparation for use and assembly	4-5.3.1.1a, 4-5.3.1.1.2	<prepuse>	
Handling	4-5.3.1.1b, 4-5.3.1.1.3	<handling>	
Stowage	4-5.3.1.1c	<stow>	
Removal	4-5.3.1.1d, 4-5.3.1.1.4	<remove>	
Disassembly	4-5.3.1.1e, 4-5.3.1.1.5	<dissam>	
Cleaning and corrosion control	4-5.3.1.1f, 4-5.3.1.1.6	<clncorr>	
Inspection	4-5.3.1.1g, 4-5.3.1.1.7	<insp>	
Service	4-5.3.1.1h	<service>	
Repair	4-5.3.1.1i, 4-5.3.1.1.8	<repair>	
Alignment	4-5.3.1.1j	<align>	
Painting	4-5.3.1.1k	<paint>	
Lubrication	4-5.3.1.1l	<lube>	
Assembly	4-5.3.1.1m, 4-5.3.1.1.9	<assem>	
Test and inspection	4-5.3.1.1n, 4-5.3.1.1.10	<test-inspect>	
Installation	4-5.3.1.1o, 4-5.1.1.1.11	<install>	
Rigging	4-5.3.1.1p	<rig>	
Adjustment	4-5.3.1.1q	<adjust>	
Calibration	4-5.3.1.1r, 4-5.3.1.1.12	<calibrate>	
Preparation for storage or shipment	4-5.3.1.1s, 4-5.3.1.1.13	<pss>	
Environmental conditioning	4-5.3.1.1t	<envircond>	
Safety information	4-5.3.1.1u, 4-5.3.1.1.14	<safe>	
Engine start and run-up	4-5.3.1.1v, 4-5.3.1.1.15	<engstart>	
Software loading	4-5.3.1.1w	<softload>	
Fabrication	4-5.3.1.1x, 4-5.3.1.1.16	<fabricate>	
Packing	4-5.3.1.1y	<packing>	
Unpacking	4-5.3.1.1z	<unpacking>	
Preservation	4-5.3.1.1aa	<preserve>	

MIL-STD-3001-1A(AS) w/CHANGE 1

APPENDIX A

TABLE A-XXXIII. AIRCRAFT SYSTEMS AND EQUIPMENT MAINTENANCE IETMs.

TM CONTENTS	MIL-STD-3001-1 REFERENCE	ELEMENT NAME	REMARKS
Tracking	4-5.3.1.1ab	<track>	
Fueling	4-5.3.1.1ac	<fuel>	
Defueling	4-5.3.1.1ad	<defuel>	
Canning	4-5.3.1.1ae	<canning>	
Decanning	4-5.3.1.1af	<decanning>	
General maintenance procedures work package	4-5.3.2	<genmaintwp>	
Ground operations work package	4-5.3.4	<grndopwp>	
Support equipment maintenance work package	4-5.3.5	<semaintwp>	
Local manufacturing and assembly work package	4-5.3.6	<locmfgrp>	
IPB data (as applicable for maintenance WPs listed above)	4-5.3.11	<ipbwp>	
Wiring/cabling diagram WP	4-5.3.12	<wirediawp>	
Wire run lists WP	4-5.3.13	<wirelistwp>	
POWER PLANT BUILD-UP WORK PACKAGES	4-5.3.7		
General information WP	4-5.3.7.1	<geninfomaintwp>	
Quick engine change kit description WP	4-5.3.7.2	<qeckdescwp>	
Quick engine change assembly WP	4-5.3.7.3	<qecawp>	
Non-quick engine change assembly WPs	4-5.3.7.4	<nonqecawp>	
Additional power plant build-up WPs	4-5.3.7.5	<bldupwp>	
Illustrated parts breakdown data (as applicable for WPs listed above)	4-5.3.11	<ipbwp>	
AIRCRAFT WIRING INFORMATION	5-5.2.3		
WIRING DIAGRAM INFORMATION			
Wiring diagram identification and information work package	5-5.2.3.2	<wdiawp>	
Introduction	5-5.2.3.2a	<intro>	
Reference designator system	5-5.2.3.2b	<titledpara>	
Individual cable numbering	5-5.2.3.2c	<titledpara>	
Electrical connector identification	5-5.2.3.2d	<titledpara>	
Splice area identification	5-5.2.3.2e	<titledpara>	
Ground point identification	5-5.2.3.2f	<titledpara>	
Individual wire identification	5-5.2.3.2g	<titledpara>	
Wiring diagram work packages	5-5.2.3.3	<wdiawp>	
Wire list work packages	5-5.2.3.4		
Wire run list WP	5-5.2.3.4.1	<wrunlstwp>	
Wiring reference designation list WP	5-5.2.3.4.2	<wrefdeswp>	
Wire and connector component identification and location list WP	5-5.2.3.5	<wcomplstwp>	
AIRCRAFT WIRE BUNDLE INFORMATION	5-5.2.4		
Wiring system bundle assembly identification and information WP	5-5.2.4.1	<bunidwp>	
Introduction	5-5.2.4.1a	<intro>	
Reference designator system	5-5.2.4.1b	<titledpara>	
Aircraft section identification	5-5.2.4.1c	<titledpara>	
Individual harness identification	5-5.2.4.1d	<titledpara>	
Individual cable numbering	5-5.2.4.1e	<titledpara>	
Electrical connector identification	5-5.2.4.1f	<titledpara>	
Splice area identification	5-5.2.4.1g	<titledpara>	
Ground point identification	5-5.2.4.1h	<titledpara>	
Individual wire identification	5-5.2.4.1i	<titledpara>	
Circuit identification	5-5.2.4.1j	<titledpara>	
Access information work package	5-5.2.4.2	<accessinfowp>	
Introduction	5-5.2.4.2	<intro>	
Access information	5-5.2.4.2	<accessinfo>	

MIL-STD-3001-1A(AS) w/CHANGE 1

APPENDIX A

TABLE A-XXXIII. AIRCRAFT SYSTEMS AND EQUIPMENT MAINTENANCE IETMs.

TM CONTENTS	MIL-STD-3001-1 REFERENCE	ELEMENT NAME	REMARKS
Wire bundle assembly routing WPs	5-5.2.4.3	<bunroutewp>	
Introduction	5-5.2.4.3	<intro>	
Wire bundle assembly routing information	5-5.2.4.3	<titledpara>	
Bundle routing parts list	5-5.2.4.3	<bunroutepl>	
AIRCRAFT WIRING CONNECTOR REPAIR IDENTIFICATION	5-5.2.5		
Wiring systems repair identification and information work package	5-5.2.5.2	<wrepidwp>	
Introduction	5-5.2.5.2a	<intro>	
Reference designator system	5-5.2.5.2b	<titledpara>	
Electrical connector identification	5-5.2.5.2c	<titledpara>	
Splice area identification	5-5.2.5.2d	<titledpara>	
Ground point identification	5-5.2.5.2e	<titledpara>	
Individual wire identification	5-5.2.5.2f	<titledpara>	
Wiring system component repair tool list WP	5-5.2.5.3	<comprelistwp>	
Introduction	5-5.2.5.1	<intro>	
Component repair tool list	5-5.2.5.3	<comprelist>	
Aircraft specific wiring systems repair kit WP	5-5.2.5.4	<reprkitwp>	
Introduction	5-5.2.5.1	<intro>	
Repair tool kit parts list	5-5.2.5.4	<reprkitlist>	
Wire type list WP	5-5.2.5.5	<wtypelistwp>	
Introduction	5-5.2.5.1	<intro>	
Wire type list	5-5.2.5.5	<wtypelist>	
Aircraft specific repair tools WP	5-5.2.5.6	<reptoolwp>	
Introduction	5-5.2.5.1	<intro>	
General description	5-5.2.5.6a	<intro>	
Repair procedures	5-5.2.5.6b	<maintproc>	
Adjustments	5-5.2.5.6c	<maintproc>	
Inspection	5-5.2.5.6d	<maintproc>	
Additional repair data	5-5.2.5.6e	<maintproc>	
Wiring system connector component repair WP	5-5.2.5.7	<wcomprepwp>	
Introduction	5-5.2.5.7	<intro>	
Description	5-5.2.5.7	<wiringcompdesc>	
Maintenance procedures	5-5.2.5.7	<maintproc>	
Aircraft cable assembly parts data WP	5-5.2.5.8	<partswp>	
Introduction	5-5.2.5.1	<intro>	
Repair parts data	5-5.2.5.8	<partsdata>	
STRUCTURAL REPAIR INFORMATION	6-5.2.3		
AIRCRAFT STRUCTURAL REPAIR DATA	6-5.2.3		
Aircraft structure visual index WP	6-5.2.3.1	<repindxwp>	
Introduction	6-5.2.3	<intro>	
Visual index	6-5.2.3.1	<repindx>	
General aircraft structural information work package	6-5.2.3.2	<genstructwp>	
Introduction	6-5.2.3	<intro>	
Aircraft structural description	6-5.2.3.2.1	<structrepair>	
Aircraft leveling and alignment	6-5.2.3.2.2	<structrepair>	
Contour data	6-5.2.3.2.3	<structrepair>	
In-service tolerance	6-5.2.3.2.4	<structrepair>	
Common shop practices	6-5.2.3.2.5	<structrepair>	
Repair materials	6-5.2.3.2.6	<structrepair>	
Support of structure	6-5.2.3.2.7	<structrepair>	
Crash handling and shipping	6-5.2.3.2.8	<structrepair>	
Typical repair data WPs	6-5.2.3.3	<typrepwp>	
Introduction	6-5.2.3	<intro>	

MIL-STD-3001-1A(AS) w/CHANGE 1

APPENDIX A

TABLE A-XXXIII. AIRCRAFT SYSTEMS AND EQUIPMENT MAINTENANCE IETMs.

TM CONTENTS	MIL-STD-3001-1 REFERENCE	ELEMENT NAME	REMARKS
Skin patch repair	6-5.2.3.3a	<typrepproc>	
Transparent panel repair	6-5.2.3.3b	<typrepproc>	
Honeycomb structure repair	6-5.2.3.3c	<typrepproc>	
Extrusion repair	6-5.2.3.3d	<typrepproc>	
Sealed area repair	6-5.2.3.3e	<typrepproc>	
Formed structure repair	6-5.2.3.3f	<typrepproc>	
Plastic repair	6-5.2.3.3g	<typrepproc>	
New/peculiar structure repair	6-5.2.3.3.1	<typrepproc>	
Specific repair data WPs	6-5.2.3.4	<specrepwp>	
Introduction	6-5.2.3	<intro>	
Damage identification and evaluation data	6-5.2.3.4.1	<damage>	
Typical repair procedures (when applicable)	6-5.2.3.4.2	<typrepproc>	
Specific repair procedures	6-5.2.3.4.3	<specrepwp>	
Illustrated parts breakdown data*	6-5.2.3.4.3.8, 6-5.2.6	<ipb-structdata>	
Structural group repair visual index illustrated WP (*included in all specific repairs for structural repair data)	6-5.2.3.4	<repindxwp>	
CORROSION CONTROL DATA	6-5.2.4		
Corrosion control materials requirements WP	6-5.2.4.1	<corformatwp>	
Introduction	6-5.2.4	<intro>	
Corrosion control materials lists	6-5.2.4.1	<corformatlist>	
General information WP	6-5.2.4.2	<geninfowp>	
Introduction	6-5.2.4	<intro>	
Protective covers	6-5.2.4.2.1	<titledpara>	
Corrosion prone areas	6-5.2.4.2.2	<titledpara>	
Typical corrosion control data WPs	6-5.2.4.3.1	<typcorwp>	
Introduction	6-5.2.4	<intro>	
Typical procedures	6-5.2.4.3.1	<titledpara>	
Inspection for corrosion WP	6-5.2.4.3.2	<corinspwp>	
Introduction	6-5.2.4	<intro>	
Cleaning procedures	6-5.2.4.3.2a	<titledpara>	
Inspection by methods appropriate to the area on the aircraft	6-5.2.4.3.2b	<titledpara>	
References	6-5.2.4.3.2c	<titledpara>	
Criteria for recognizing and evaluating corrosion damage	6-5.2.4.3.2d	<titledpara>	
Cleaning WPs	6-5.2.4.3.3	<corclnwp>	
Introduction	6-5.2.4	<intro>	
Cleaning procedures	6-5.2.4.3.3	<structrepair>	
Stripping WPs	6-5.2.4.3.4	<stripwp>	
Introduction	6-5.2.4	<intro>	
Stripping procedures	6-5.2.4.3.4	<proc>	
Corrosion removal WPs	6-5.2.4.3.5	<corremwp>	
Introduction	6-5.2.4	<intro>	
Corrosion removal procedures	6-5.2.4.3.5	<proc>	
Chemical treatment of metal surfaces WPs	6-5.2.4.3.6	<chemtrtwp>	
Introduction	6-5.2.4	<intro>	
Chemical treatment procedures	6-5.2.4.3.6	<structrepair>	
Corrosion control seals and sealants WPs	6-5.2.4.3.7	<corsealwp>	
Introduction	6-5.2.4	<intro>	
Seals and sealants procedures	6-5.2.4.3.7	<structrepair>	
Paint systems WPs	6-5.2.4.3.8	<paintsyswp>	
Introduction	6-5.2.4	<intro>	

MIL-STD-3001-1A(AS) w/CHANGE 1

APPENDIX A

TABLE A-XXXIII. AIRCRAFT SYSTEMS AND EQUIPMENT MAINTENANCE IETMs.

TM CONTENTS	MIL-STD-3001-1 REFERENCE	ELEMENT NAME	REMARKS
Exterior marking	6-5.2.4.3.8.1	<titledpara>	
Interior markings	6-5.2.4.3.8.2	<titledpara>	
NONDESTRUCTIVE INSPECTION (NDI) DATA	6-5.2.5	<ndigeninfowp>	
NDI general information WP	6-5.2.5.1	<intro>	
Introduction	6-5.2.5	<titledpara>	
General information	6-5.2.5.1	<nditywp>	
NDI typical procedures WPs	6-5.2.5.2	<intro>	
Introduction	6-5.2.5	<structrepair>	
Typical procedures	6-5.2.5.2	<ndindxwp>	
NDI index WP	6-5.2.5.3	<intro>	
Introduction	6-5.2.5	<ndindxlist>	
NDI index	6-5.2.5.3c	<ndispecwp>	
NDI specific procedures WPs	6-5.2.5.4	<intro>	
Introduction	6-5.2.5	<itemnom>	
Item nomenclature	6-5.2.5.4.1	<itemdesc>	
Item description	6-5.2.5.4.2	<defdesc>	
Defect description	6-5.2.5.4.3	<priproc>	
Primary NDI procedure	6-5.2.5.4.4	<bkupproc>	
Backup NDI procedure	6-5.2.5.4.5	<ipb-structdata>	
Illustrated parts breakdown data** (**included in all specific repairs for NDI data)	6-5.2.6		

MIL-STD-3001-1A(AS) w/CHANGE 1

APPENDIX A

TABLE A-XXXIV. AERONAUTICAL EQUIPMENT, AIRBORNE WEAPONS/EQUIPMENT, AND SUPPORT EQUIPMENT OPERATION AND MAINTENANCE IETMs.

TM CONTENTS	MIL-STD-3001-1 REFERENCE	ELEMENT NAME	REMARKS
FRONT MATTER AND SUPPORTING INFORMATION	1-C.5.3		
CD label and flyleaf data	1-C.5.3.1		
Title page	1-C.5.3.2	<titlepg>	
Revision summary data	1-C.5.3.3	<revision-summary-info>	
Table of contents	1-C.5.3.4		
How to use this IETM information	1-C.5.3.5	<how-to-use-etm>	
Acronyms and abbreviations list	1-C.5.3.6	<abbrevlist>	
Effectivity information	1-C.5.3.7	<consoleffectlist>	
Supporting information WPs	1-C.5.4	<supportinfo>	
Hazardous materials warning summary (HMWS) WP	1-C.5.4.1	<hmwswp>	
Consolidated numerical index of part numbers WP	1-C.5.4.2	<partnoindxwp>	
Consolidated numerical index of reference designations WP	1-C.5.4.3	<refdesindxwp>	
Historical record of applicable technical directives	1-C.5.4.4	<hratd>	
Consolidated list of support equipment required	1-C.5.4.5	<sereq>	
Consolidated list of materials required	1-C.5.4.6	<matreq>	
Consolidated list of reference material	1-C.5.4.7	<refmat>	
Maintenance allocation WP (engine intermediate maintenance only)	1-C.5.4.8	<maintalwp>	
<i>NOTE: As applicable, all work packages shall include work package title and setup information.</i>			
DESCRIPTION AND PRINCIPLES OF OPERATION DATA	2-5.1, 2-5.2.3		
DESCRIPTION WORK PACKAGES	2-5.2.4		
Aeronautical equipment, airborne weapons/equipment, and support equipment description WPs	2-5.2.4.2.2	<descwp>	
Introduction	2-5.2.4.2	<intro>	
System description	2-5.2.4.2.2	<sysdesc>	
Subsystem description	2-5.2.4.2.2	<sysdesc>	
Component description	2-5.2.4.2.2	<sysdesc>	
Controls and indicators descriptions	2-5.2.4.2.1.1	<ctrlinddesc>	
PROGRAMMING SOFTWARE DESCRIPTION WORK PACKAGES	2-5.2.4.2.4	<softwp>	
Introduction	2-5.2.4.2.4	<intro>	
Stimulus and measurement programming	2-5.2.4.2.4	<stim-measdesc>	
Programming statements	2-5.2.4.2.4	<statedesc>	
Programming tests or self tests	2-5.2.4.2.4	<progtestdesc>	
PRINCIPLES OF OPERATION WORK PACKAGES	2-5.2.5		
Aeronautical equipment, airborne weapons/equipment, and support equipment principles of operation work packages	2-5.2.5.2	<popwp>	
Introduction	2-5.2.5.2	<intro>	
System description	2-5.2.4.2.2	<sysdesc>	
System principles of operation	2-5.2.5.2	<systry>	
Subsystem description	2-5.2.4.2.2	<sysdesc>	
Subsystem principles of operation	2-5.2.5.2	<systry>	
Component description	2-5.2.4.2.2	<sysdesc>	
Component principles of operation	2-5.2.5.2	<systry>	

MIL-STD-3001-1A(AS) w/CHANGE 1

APPENDIX A

TABLE A-XXXIV. AERONAUTICAL EQUIPMENT, AIRBORNE WEAPONS/EQUIPMENT, AND SUPPORT EQUIPMENT OPERATION AND MAINTENANCE IETMs.

TM CONTENTS	MIL-STD-3001-1 REFERENCE	ELEMENT NAME	REMARKS
SCHEMATIC DIAGRAM WORK PACKAGES	2-5.2.5.4, 3-5.3.4.6.1	<schemwp>	
Introduction	2-5.2.5.4	<intro>	
OPERATION INSTRUCTION WORK PACKAGES	2-5.2.6		
Operating instruction WPs	2-5.2.6.1	<operwp>	
Introduction	2-5.2.6.1	<intro>	
Equipment preparation for use	2-5.2.6.1a	<prepuse>	
Pre-operational setup procedures	2-5.2.6.1b	<preop>	
Start-up procedures	2-5.2.6.1c	<startup>	
Controls and indicators descriptions	2-5.2.6.1d	<ctrlinddesc>	
Built-in-test or self-test procedures	2-5.2.6.1e	<bit-st-op>	
Operating procedures	2-5.2.6.1f	<op-proc>	
Emergency operation	2-5.2.6.1g	<emerg-proc>	
Emergency shutdown procedures	2-5.2.6.1h	<emshut-proc>	
Post-operational shutdown procedures	2-5.2.6.1i	<post-op-proc>	
Software loading WPs	2-5.2.6.2	<softldwp>	
TESTING AND TROUBLESHOOTING DATA	3-5.1, 3-5.1.3, 3-5.2		
Aeronautical equipment, airborne weapons/equipment, and support equipment testing and troubleshooting WPs	3-5.3.5		
Testing WPs	3-5.3.4.6.3	<opchkwp>	
Introduction	3-5.3.4.6.3a	<intro>	
General procedures and precautions	3-5.3.4.6.3b	<genproc>	
Pretest setup procedures	3-5.3.4.6.3c	<pretest>	
Testing procedures	3-5.3.4.6.3d	<opchk>	
Post-testing shutdown procedures	3-5.3.4.6.3e	<shutdown> <emergshdn>	
Troubleshooting WPs	3-5.3.4.6.4	<trblshwtp>	
Introduction	3-5.3.4.6.4a	<intro>	
General procedures and precautions	3-5.3.4.6.4b	<genproc>	
Troubleshooting procedures	3-5.3.4.6.4c	<trblsh>	
Post-testing shutdown procedures	3-5.3.4.6.4d	<shutdown> <emergshdn>	
Combined testing and troubleshooting WPs	3-5.3.4.6.5	<tst-trblwtp>	
Introduction	3-5.3.4.6.5a	<intro>	
General procedures and precautions	3-5.3.4.6.5b	<genproc>	
Pretest setup procedures	3-5.3.4.6.5c	<pretest>	
Testing and troubleshooting procedures	3-5.3.4.6.5d	<opck-trblproc>	
Post-testing shutdown procedures	3-5.3.4.6.5e	<shutdown> <emergshdn>	
MAINTENANCE INFORMATION WITH IPB	4-5.3		
MAINTENANCE WPs	4-5.3.1	<maintwp>	
Introduction	4-5.3	<intro>	
Maintenance tasks	4-5.3.1.1		
Preparation for use and assembly	4-5.3.1.1a, 4-5.3.1.1.2	<prepuse>	
Handling	4-5.3.1.1b, 4-5.3.1.1.3	<handling>	
Stowage	4-5.3.1.1c	<stow>	
Removal	4-5.3.1.1d, 4-5.3.1.1.4	<remove>	

MIL-STD-3001-1A(AS) w/CHANGE 1

APPENDIX A

TABLE A-XXXIV. AERONAUTICAL EQUIPMENT, AIRBORNE WEAPONS/EQUIPMENT, AND SUPPORT EQUIPMENT OPERATION AND MAINTENANCE IETMs.

TM CONTENTS	MIL-STD-3001-1 REFERENCE	ELEMENT NAME	REMARKS
Disassembly	4-5.3.1.1e, 4-5.3.1.1.5	<dissam>	
Cleaning and corrosion control	4-5.3.1.1f, 4-5.3.1.1.6	<clncorr>	
Inspection	4-5.3.1.1g, 4-5.3.1.1.7	<insp>	
Service	4-5.3.1.1h	<service>	
Repair	4-5.3.1.1i, 4-5.3.1.1.8	<repair>	
Alignment	4-5.3.1.1j	<align>	
Painting	4-5.3.1.1k	<paint>	
Lubrication	4-5.3.1.1l	<lube>	
Assembly	4-5.3.1.1m, 4-5.3.1.1.9	<assem>	
Test and inspection	4-5.3.1.1n, 4-5.3.1.1.10	<test-inspect>	
Installation	4-5.3.1.1o, 4-5.1.1.1.11	<install>	
Rigging	4-5.3.1.1p	<rig>	
Adjustment	4-5.3.1.1q	<adjust>	
Calibration	4-5.3.1.1r, 4-5.3.1.1.12	<calibrate>	
Preparation for storage or shipment	4-5.3.1.1s, 4-5.3.1.1.13	<pss>	
Environmental conditioning	4-5.3.1.1t	<envircond>	
Safety information	4-5.3.1.1u, 4-5.3.1.1.14	<safe>	
Engine start and run-up	4-5.3.1.1v, 4-5.3.1.1.15	<engstart>	
Software loading	4-5.3.1.1w	<softload>	
Fabrication	4-5.3.1.1x, 4-5.3.1.1.16	<fabricate>	
Packing	4-5.3.1.1y	<packing>	
Unpacking	4-5.3.1.1z	<unpacking>	
Preservation	4-5.3.1.1aa	<preserve>	
Tracking	4-5.3.1.1ab	<track>	
Fueling	4-5.3.1.1ac	<fuel>	
Defueling	4-5.3.1.1ad	<defuel>	
Canning	4-5.3.1.1ae	<canning>	
Decanning	4-5.3.1.1af	<decanning>	
General maintenance procedures work package	4-5.3.2	<genmaintwp>	
Support equipment maintenance work package	4-5.3.5	<semaintwp>	
Local manufacturing and assembly work package	4-5.3.6	<locmfgwp>	
IPB data (as applicable for maintenance WPs listed above)	4-5.3.11	<ipbwp>	
EQUIPMENT WIRING INFORMATION	5-5.2.3		
WIRING DIAGRAM INFORMATION			
Wiring diagram identification and information work package	5-5.2.3.2	<wdiaidwp>	
Introduction	5-5.2.3.2a	<intro>	
Reference designator system	5-5.2.3.2b	<titledpara>	
Individual cable numbering	5-5.2.3.2c	<titledpara>	
Electrical connector identification	5-5.2.3.2d	<titledpara>	

MIL-STD-3001-1A(AS) w/CHANGE 1

APPENDIX A

TABLE A-XXXIV. AERONAUTICAL EQUIPMENT, AIRBORNE WEAPONS/EQUIPMENT, AND SUPPORT EQUIPMENT OPERATION AND MAINTENANCE IETMs.

TM CONTENTS	MIL-STD-3001-1 REFERENCE	ELEMENT NAME	REMARKS
Splice area identification	5-5.2.3.2e	<titledpara>	
Ground point identification	5-5.2.3.2f	<titledpara>	
Individual wire identification	5-5.2.3.2g	<titledpara>	
Wiring diagram work packages	5-5.2.3.3	<wdiawp>	
Wire list work packages	5-5.2.3.4		
Wire run list WP	5-5.2.3.4.1	<wrunlstwp>	
Wiring reference designation list WP	5-5.2.3.4.2	<wrefdeswp>	
Wire and connector component identification and location list WP	5-5.2.3.5	<wcomplstwp>	

MIL-STD-3001-1A(AS) w/CHANGE 1

APPENDIX A

TABLE A-XXXV. TRAINING SYSTEMS OPERATION AND MAINTENANCE IETMs.

TM CONTENTS	MIL-STD-3001-1 REFERENCE	ELEMENT NAME	REMARKS
FRONT MATTER AND SUPPORTING INFORMATION	1-C.5.3		
CD label and flyleaf data	1-C.5.3.1		
Title page data	1-C.5.3.2	<titlepg>	
Revision summary data	1-C.5.3.3	<revision-summary-info>	
Table of contents	1-C.5.3.4		
How to use this IETM information	1-C.5.3.5	<how-to-use-etm>	
Acronyms and abbreviations list	1-C.5.3.6	<abbrevlist>	
Effectivity information	1-C.5.3.7	<consoleffectlist>	
Supporting information WPs	1-C.5.4	<supportinfo>	
Hazardous materials warning summary (HMWS) WP	1-C.5.4.1	<hmwswp>	
Consolidated numerical index of part numbers WP	1-C.5.4.2	<partnoindxwp>	
Consolidated numerical index of reference designations WP	1-C.5.4.3	<refdesindxwp>	
Historical record of applicable technical directives	1-C.5.4.4	<hratd>	
Consolidated list of support equipment required	1-C.5.4.5	<sereq>	
Consolidated list of materials required	1-C.5.4.6	<matreq>	
Consolidated list of reference material	1-C.5.4.7	<refmat>	
Safety summary WP	1-C.5.4.9	<safewp>	
<i>NOTE: As applicable, all work packages shall include work package title and setup information.</i>			
DESCRIPTION AND PRINCIPLES OF OPERATION DATA	2-5.1, 2-5.2.3		
DESCRIPTION WORK PACKAGES	2-5.2.4		
Description WPs	2-5.2.4.2.2	<descwp>	
Introduction	2-5.2.4.2	<intro>	
System description	2-5.2.4.2.2	<sysdesc>	
Subsystem description	2-5.2.4.2.2	<sysdesc>	
Component description	2-5.2.4.2.2	<sysdesc>	
Controls and indicators descriptions	2-5.2.4.2.1.1	<ctrlinddesc>	
PROGRAMMING SOFTWARE DESCRIPTION WORK PACKAGES	2-5.2.4.2.4	<softwp>	
Introduction	2-5.2.4.2.4	<intro>	
Stimulus and measurement programming	2-5.2.4.2.4	<stim-measdesc>	
Programming statements	2-5.2.4.2.4	<statedesc>	
Programming tests or self tests	2-5.2.4.2.4	<progtestdesc>	
PRINCIPLES OF OPERATION WORK PACKAGES	2-5.2.5		
Principles of operation work packages	2-5.2.5.2	<popwp>	
Introduction	2-5.2.5.2	<intro>	
System description	2-5.2.4.2.2	<sysdesc>	
System principles of operation	2-5.2.5.2	<systhry>	
Subsystem description	2-5.2.4.2.2	<sysdesc>	
Subsystem principles of operation	2-5.2.5.2	<systhry>	
Component description	2-5.2.4.2.2	<sysdesc>	
Component principles of operation	2-5.2.5.2	<systhry>	
SCHEMATIC DIAGRAM WORK PACKAGES	2-5.2.5.4, 3-5.3.4.6.1	<schemwp>	
Introduction	2-5.2.5.4	<intro>	
OPERATION INSTRUCTION WORK PACKAGES	2-5.2.6		
Operating instruction WPs	2-5.2.6.1	<operwp>	
Introduction	2-5.2.6.1	<intro>	
Equipment preparation for use	2-5.2.6.1a	<prepuse>	

MIL-STD-3001-1A(AS) w/CHANGE 1

APPENDIX A

TABLE A-XXXV. TRAINING SYSTEMS OPERATION AND MAINTENANCE IETMs.

TM CONTENTS	MIL-STD-3001-1 REFERENCE	ELEMENT NAME	REMARKS
Pre-operational setup procedures	2-5.2.6.1b	<preop>	
Start-up procedures	2-5.2.6.1c	<startup>	
Controls and indicators descriptions	2-5.2.6.1d	<ctrlinddesc>	
Built-in-test or self-test procedures	2-5.2.6.1e	<bit-st-op>	
Operating procedures	2-5.2.6.1f	<op-proc>	
Emergency operation	2-5.2.6.1g	<emerg-proc>	
Emergency shutdown procedures	2-5.2.6.1h	<emshut-proc>	
Post-operational shutdown procedures	2-5.2.6.1i	<post-op-proc>	
Software loading WPs	2-5.2.6.2	<softldwp>	
TESTING AND TROUBLESHOOTING DATA	3-5.1, 3-5.1.3, 3-5.2		
Testing and troubleshooting WPs	3-5.3.5		
Troubleshooting WPs	3-5.3.4.6.4	<trblshtwp>	
Introduction	3-5.3.4.6.4a	<intro>	
General procedures and precautions	3-5.3.4.6.4b	<genproc>	
Troubleshooting procedures	3-5.3.4.6.4c	<trblsht>	
Post-testing shutdown procedures	3-5.3.4.6.4d	<shutdown> <emergshtdn>	
MAINTENANCE INFORMATION WITH IPB	4-5.3		
Maintenance WPs	4-5.3.1	<maintwp>	
Introduction	4-5.3	<intro>	
Maintenance tasks	4-5.3.1.1		
Preparation for use and assembly	4-5.3.1.1a, 4-5.3.1.1.2	<prepuse>	
Handling	4-5.3.1.1b, 4-5.3.1.1.3	<handling>	
Stowage	4-5.3.1.1c	<stow>	
Removal	4-5.3.1.1d, 4-5.3.1.1.4	<remove>	
Disassembly	4-5.3.1.1e, 4-5.3.1.1.5	<dissam>	
Cleaning and corrosion control	4-5.3.1.1f, 4-5.3.1.1.6	<clncorr>	
Inspection	4-5.3.1.1g, 4-5.3.1.1.7	<insp>	
Service	4-5.3.1.1h	<service>	
Repair	4-5.3.1.1i, 4-5.3.1.1.8	<repair>	
Alignment	4-5.3.1.1j	<align>	
Painting	4-5.3.1.1k	<paint>	
Lubrication	4-5.3.1.1l	<lube>	
Assembly	4-5.3.1.1m, 4-5.3.1.1.9	<assem>	
Test and inspection	4-5.3.1.1n, 4-5.3.1.1.10	<test-inspect>	
Installation	4-5.3.1.1o, 4-5.1.1.1.11	<install>	
Rigging	4-5.3.1.1p	<rig>	
Adjustment	4-5.3.1.1q	<adjust>	
Calibration	4-5.3.1.1r, 4-5.3.1.1.12	<calibrate>	
Preparation for storage or shipment	4-5.3.1.1s, 4-5.3.1.1.13	<pss>	
Environmental conditioning	4-5.3.1.1t	<envircond>	

MIL-STD-3001-1A(AS) w/CHANGE 1

APPENDIX A

TABLE A-XXXV. TRAINING SYSTEMS OPERATION AND MAINTENANCE IETMs.

TM CONTENTS	MIL-STD-3001-1 REFERENCE	ELEMENT NAME	REMARKS
Safety information	4-5.3.1.lu, 4-5.3.1.1.14	<safe>	
Software loading	4-5.3.1.1w	<softload>	
Packing	4-5.3.1.1y	<packing>	
Unpacking	4-5.3.1.1z	<unpacking>	
Preservation	4-5.3.1.1aa	<preserve>	
Tracking	4-5.3.1.1ab	<track>	
General maintenance procedures work package	4-5.3.2	<genmaintwp>	
Support equipment maintenance work package	4-5.3.5	<semaintwp>	
Local manufacturing and assembly work package	4-5.3.6	<locmfgwp>	
IPB data (as applicable for maintenance WPs listed above)	4-5.3.11	<ipbwp>	
Wiring/cabling diagram WP	4-5.3.12	<wirediawp>	
Wire run lists WP	4-5.3.13	<wirelistwp>	

MIL-STD-3001-1A(AS) w/CHANGE 1

APPENDIX A

TABLE A-XXXVI. ENGINE INTERMEDIATE AND DEPOT MAINTENANCE IETMs.

TM CONTENTS	MIL-STD-3001-1 REFERENCE	ELEMENT NAME	REMARKS
FRONT MATTER AND SUPPORTING INFORMATION	1-C.5.3		
CD label and flyleaf data	1-C.5.3.1		
Title page	1-C.5.3.2	<titlepg>	
Revision summary data	1-C.5.3.3	<revision-summary-info>	
Table of contents	1-C.5.3.4		
How to use this IETM information	1-C.5.3.5	<how-to-use-etm>	
Acronyms and abbreviations list	1-C.5.3.6	<abbrevlist>	
Effectivity information	1-C.5.3.7	<consoleffectlist>	
Supporting information WPs	1-C.5.4	<supportinfo>	
Hazardous materials warning summary (HMWS) WP	1-C.5.4.1	<hmwswp>	
Consolidated numerical index of part numbers WP	1-C.5.4.2	<partnoindxwp>	
Consolidated numerical index of reference designations WP	1-C.5.4.3	<refdesindxwp>	
Historical record of applicable technical directives	1-C.5.4.4	<hratd>	
Consolidated list of support equipment required	1-C.5.4.5	<sereq>	
Consolidated list of materials required	1-C.5.4.6	<matreq>	
Consolidated list of reference material	1-C.5.4.7	<refmat>	
Maintenance allocation WP (engine intermediate maintenance only)	1-C.5.4.8	<maintalwp>	
<i>NOTE: As applicable, all work packages shall include work package title and setup information.</i>			
DESCRIPTION AND PRINCIPLES OF OPERATION DATA	2-5.1, 2-5.2.3		
DESCRIPTION WORK PACKAGES	2-5.2.3, 2-5.2.4		
Engine and engine systems description work packages	2-5.2.4.2.3	<descwp>	
Introduction	2-5.2.4.2	<intro>	
System description	2-5.2.4.2.3	<sysdesc>	
Subsystem description	2-5.2.4.2.3	<sysdesc>	
Component description	2-5.2.4.2.3	<sysdesc>	
Controls and indicators descriptions	2-5.2.4.2.1.1	<ctrlinddesc>	
PRINCIPLES OF OPERATION WORK PACKAGES	2-5.2.5		
Engine systems principles of operation work packages	2-5.2.5.3	<popwp>	
Introduction	2-5.2.5.3	<intro>	
System description	2-5.2.4.2.3	<sysdesc>	
System principles of operation	2-5.2.5.3	<systhry>	
Subsystem description	2-5.2.4.2.3	<sysdesc>	
Subsystem principles of operation	2-5.2.5.3	<systhry>	
Component description	2-5.2.4.2.3	<sysdesc>	
Component principles of operation	2-5.2.5.3	<systhry>	
SCHEMATIC DIAGRAM WORK PACKAGES	2-5.2.5.4	<schemwp>	
Introduction	2-5.2.5.4	<intro>	
TESTING AND TROUBLESHOOTING DATA	3-5.1, 3-5.1.4, 3-5.3.3		
Engine testing and troubleshooting WPs	3-5.1, 3-5.1.4, 3-5.3.3		
Engine testing and troubleshooting WPs	3-5.3.6		
Engine testing procedures WP	3-5.3.6.1	<engtestwp>	
Introduction	3-5.3.6.1a	<intro>	
General procedures and precautions	3-5.3.6.1b	<genproc>	
Standard charts and conversion tables	3-5.3.6.1c	<perfevaldata>	
Testing required after special repairs	3-5.3.6.1d	<specreptst>	

MIL-STD-3001-1A(AS) w/CHANGE 1

APPENDIX A

TABLE A-XXXVI. ENGINE INTERMEDIATE AND DEPOT MAINTENANCE IETMs.

TM CONTENTS	MIL-STD-3001-1 REFERENCE	ELEMENT NAME	REMARKS
Test requirements	3-5.3.6.1e	<testreq>	
Engine inspection	3-5.3.6.1f	<enginspect>	
Abnormal conditions during operation	3-5.3.6.1g	<abnormcond>	
Engine operation under unusual conditions	3-5.3.6.1h	<unusualcond>	
Engine operating limits	3-5.3.6.1i	<oplimit>	
Engine start	3-5.3.6.1j	<engstart>	
Preparation for test	3-5.3.6.1k	<testprep>	
Engine test	3-5.3.6.1l	<engtest>	
Engine shutdown	3-5.3.6.1m	<shutdown>	
		<emergshdn>	
Engine post-test	3-5.3.6.1n	<postest>	
Engine troubleshooting WPs	3-5.3.6.2	<trblshtwp>	
Introduction	3-5.3.6.2a	<intro>	
General procedures and precautions	3-5.3.6.2b	<genproc>	
Troubleshooting procedures	3-5.3.6.2c	<trblsht>	
Post-operational shutdown procedures	3-5.3.6.2d	<shutdown>	
		<emergshdn>	
MAINTENANCE INFORMATION WITH IPB	4-5.3		
MAINTENANCE WPs	4-5.3.1	<maintwp>	
Introduction	4-5.3	<intro>	
Maintenance tasks	4-5.3.1.1		
Preparation for use and assembly	4-5.3.1.1a,	<prepuse>	
	4-5.3.1.1.2		
Handling	4-5.3.1.1b,	<handling>	
	4-5.3.1.1.3		
Stowage	4-5.3.1.1c	<stow>	
Removal	4-5.3.1.1d,	<remove>	
	4-5.3.1.1.4		
Disassembly	4-5.3.1.1e,	<dissam>	
	4-5.3.1.1.5		
Cleaning and corrosion control	4-5.3.1.1f,	<clncorr>	
	4-5.3.1.1.6		
Inspection	4-5.3.1.1g,	<insp>	
	4-5.3.1.1.7		
Service	4-5.3.1.1h	<service>	
Repair	4-5.3.1.1i,	<repair>	
	4-5.3.1.1.8		
Alignment	4-5.3.1.1j	<align>	
Painting	4-5.3.1.1k	<paint>	
Lubrication	4-5.3.1.1l	<lube>	
Assembly	4-5.3.1.1m,	<assem>	
	4-5.3.1.1.9		
Test and inspection	4-5.3.1.1n,	<test-inspect>	
	4-5.3.1.1.10		
Installation	4-5.3.1.1o,	<install>	
	4-5.1.1.1.11		
Rigging	4-5.3.1.1p	<rig>	
Adjustment	4-5.3.1.1q	<adjust>	
Calibration	4-5.3.1.1r,	<calibrate>	
	4-5.3.1.1.12		
Preparation for storage or shipment	4-5.3.1.1s,	<pss>	
	4-5.3.1.1.13		
Environmental conditioning	4-5.3.1.1t	<envircond>	

MIL-STD-3001-1A(AS) w/CHANGE 1

APPENDIX A

TABLE A-XXXVI. ENGINE INTERMEDIATE AND DEPOT MAINTENANCE IETMs.

TM CONTENTS	MIL-STD-3001-1 REFERENCE	ELEMENT NAME	REMARKS
Safety information	4-5.3.1.1u, 4-5.3.1.1.14	<safe>	
Engine start and run-up	4-5.3.1.1v, 4-5.3.1.1.15	<engstart>	
Software loading	4-5.3.1.1w	<softload>	
Fabrication	4-5.3.1.1x, 4-5.3.1.1.16	<fabricate>	
Packing	4-5.3.1.1y	<packing>	
Unpacking	4-5.3.1.1z	<unpacking>	
Preservation	4-5.3.1.1aa	<preserve>	
Tracking	4-5.3.1.1ab	<track>	
Fueling	4-5.3.1.1ac	<fuel>	
Defueling	4-5.3.1.1ad	<defuel>	
Canning	4-5.3.1.1ae	<canning>	
Decanning	4-5.3.1.1af	<decanning>	
General maintenance procedures work package	4-5.3.2	<genmaintwp>	
Support equipment maintenance work package	4-5.3.5	<semaintwp>	
Local manufacturing and assembly work package	4-5.3.6	<locmfgwp>	
Preinduction and mandatory inspection WP	4-5.3.8	<preindinswp>	
External tubing, cabling and clamping WPs	4-5.3.9		
Numerical index WP	4-5.3.9.1	<compindwp>	
Bracket installation WP	4-5.3.9.2	<brktwp>	
External components WP	4-5.3.9.3	<extcompwp>	
External tubing, cabling and clamping installation WP	4-5.3.9.4	<extubwp>	
Critical clearances WP	4-5.3.9.5	<critclwp>	
IPB data (as applicable for maintenance WPs listed above)	4-5.3.11	<ipbwp>	
ENGINE WIRING INFORMATION	5-5.2.3		
WIRING DIAGRAM INFORMATION			
Wiring diagram identification and information work package	5-5.2.3.2	<wdiaidwp>	
Introduction	5-5.2.3.2a	<intro>	
Reference designator system	5-5.2.3.2b	<titledpara>	
Individual cable numbering	5-5.2.3.2c	<titledpara>	
Electrical connector identification	5-5.2.3.2d	<titledpara>	
Splice area identification	5-5.2.3.2e	<titledpara>	
Ground point identification	5-5.2.3.2f	<titledpara>	
Individual wire identification	5-5.2.3.2g	<titledpara>	
Wiring diagram work packages	5-5.2.3.3	<wdiawp>	
Wire list work packages	5-5.2.3.4		
Wire run list WP	5-5.2.3.4.1	<wrunlstwp>	
Wiring reference designation list WP	5-5.2.3.4.2	<wrefdeswp>	
Wire and connector component identification and location list WP	5-5.2.3.5	<wcomplstwp>	

MIL-STD-3001-1A(AS) w/CHANGE 1

APPENDIX B

APPENDIX B - PREPARATION REQUIREMENTS FOR PAGE-BASED PRINTED AND SCREEN DISPLAYED PDF TECHNICAL MANUALS**B.1 SCOPE**

B.1.1 Scope. This appendix establishes the style, format, and front matter requirements necessary to assemble and print or display complete WP TMs for aircraft weapon systems, aeronautical equipment, airborne weapons/equipment, training systems, and support equipment in a page-based format and screen displayed PDF format. This Appendix is a mandatory part of the standard. The information contained herein is intended for compliance.

B.2 APPLICABLE DOCUMENTS

The applicable documents in [Section 2](#) of MIL-STD-3001-1 apply to this appendix.

B.3 DEFINITIONS

The definitions in [Section 3](#) of MIL-STD-3001-1 apply to this appendix.

B.4 GENERAL REQUIREMENTS

B.4.1 General. The requirements for style and format, front matter, supporting information, and TM assembly instructions contained in this appendix can be used in conjunction with the technical content parts of this standard (MIL-STD-3001-2 through MIL-STD-3001-8) to assemble individual descriptive, operational, and task-oriented WPs into complete TMs. TMs and revisions to TMs prepared in accordance with these requirements can be printed and distributed on paper or can be presented in PDF on a computer screen.

B.4.2 Development of technical information. The preparing activity shall apply the requirements of aircraft, system, or equipment engineering design to the development of the technical information. Once developed, this data can be used to create NAVAIR TMs that can be arranged and formatted for screen display or printed, page-based presentation.

B.4.2.1 Work package development. Technical information developed in accordance with this standard shall be divided into individual, stand-alone units of information, hereafter referred to as WPs. A WP is specifically designed to respond to work tasks or to provide direct support of work tasks. WPs shall contain descriptive, operational, maintenance, testing and troubleshooting, support, and parts information for weapon systems, aeronautical equipment, airborne weapons/equipment, training systems, and support equipment. The technical information contained in these WPs shall be prepared and assembled in accordance with the requirements provided in this appendix.

B.5 DETAILED REQUIREMENTS

B.5.1 General. Requirements for front matter and supporting information are provided in [B.5.3](#) through [B.5.3.2](#). Style and format requirements for TMs containing WPs printed and distributed on paper or presented in page form on a computer screen are provided in [B.5.4](#) through [B.5.6](#).

MIL-STD-3001-1A(AS) w/CHANGE 1

APPENDIX B

B.5.2 Mandatory requirements. The requirements provided in this appendix for front matter and supporting information and style and format are mandatory and are intended for compliance. The requirements contained herein shall be followed to ensure that the conforming DTDs can be used to develop digital data. Additional graphics preparation guidance is contained in [Appendix D](#).

B.5.3 Front matter and supporting information organization. In addition to the technical content requirements contained in MIL-STD-3001-2 through MIL-STD-3001-8 of this standard, all TMs shall include front matter and additional supporting information that are necessary to produce these manuals in a page-based format. The front matter and supporting information are required to organize, assemble and locate the applicable technical content information provided in MIL-STD-3001-2 through MIL-STD-3001-7 into complete TMs. [Appendix A](#) of this standard provides detailed assembly and content requirements for all TMs covering operation, maintenance and parts data, at all maintenance levels through depot. The front matter identifies the manual and includes information on what is included in the manual, where the information is located and how to locate the technical information within the manual. The supporting information provides the user with an overview of the TM and an explanation of how the manual is used and how it is used with other manuals, when necessary. Front matter and supporting information consist of the following items:

- a. Title page.
- b. Numerical index of effective WPs/pages.
- c. TPDR page (revisions only).
- d. HMWS WP.
- e. Alphabetical index WP.
- f. Numerical index of part numbers WP.
- g. Numerical index of reference designations WP.
- h. Introduction WP.
- i. Consolidated lists for technical directives, support equipment, materials, and references WP.
- j. Maintenance allocation WP (**engine intermediate maintenance only**).
- k. Safety summary WP, as applicable (**training systems only**).

B.5.3.1 Front matter. Format and content requirements for page-based, printed and screen displayed PDF front matter are contained in [B.5.3.1.1](#) through [B.5.3.1.6](#).

B.5.3.1.1 Title page <titlepg>. A title page shall be prepared for all manuals. The format of the title page is shown in [figure B-1](#). The title page shall contain the following content information:

MIL-STD-3001-1A(AS) w/CHANGE 1

APPENDIX B

a. Publication number <tmidno>. The publication number assigned by the requiring activity shall be placed in the extreme upper left corner of the page. Each manual or volume thereof shall have a separate publication number assigned. If the manual is to be used jointly with other services, the “numberoftmidnos” attribute on the <manual> element shall indicate the number of services so that each publication number is formatted as a header on all TM pages. The requiring activity's publication number shall be placed above the other services' publication number(s).

b. Former publication number <pretmidno>. If the manual has been renumbered, the former publication number shall appear below the new number and shall be preceded by the word "Formerly." At the next revision, only the new number shall appear.

c. Publication date <pubdate>. The publication date or revision date shall be placed in the upper left corner, below the publication number, joint usage number, and/or former publication number.

d. Change number <chgnum> and date <chgdate>. The change number and date for a pickup revision, if applicable, shall be placed in the upper left corner, below the publication date.

e. Type of document. The words "TECHNICAL MANUAL" shall be centered on the page.

f. Publication title <prtitle>. The publication title shall consist of the level of maintenance, the manual type, and the end item nomenclature:

(1) Level of maintenance <maintlvl>. The level(s) of maintenance coverage, such as "ORGANIZATIONAL MAINTENANCE."

(2) Manual type <manualtype>. If applicable, the manual type such as "PRINCIPLES OF OPERATION" that is contained in the manual.

(3) End item nomenclature <sysnomen>. The end item nomenclature such as the system, subsystem, or equipment (including AN type designation), shall be centered below the type of manual. When applicable, the model(s), and part number(s) shall be placed below the nomenclature.

(a) Multiple AN type designations. When the manual covers more than one AN type designation, each AN type designation shall be placed sequentially below the end item nomenclature followed by the applicable model and/or part number, e.g.:

AN/ARC-300(V)1, MODEL NUMBER MXD 507, PART NUMBER 123456-801

AN/ARC-300(V)2, MODEL NUMBER MXD 508, PART NUMBER 123456-802

or

MIL-STD-3001-1A(AS) w/CHANGE 1

APPENDIX B

RT-2099/ARC-300 (V), P/N 45678-801

RT-2099/ARC-300 (V), P/N 45678-802.

If applicable, an effectivity statement reflecting tail numbers, BuNos, model numbers, serial numbers, etc., covered by the TM shall be added immediately following the end item nomenclature.

(b) **System coverage of multiple end items <syscomp>**. When a single manual is authorized to cover a system, all system components shall be listed below the system nomenclature. The caption "Consisting of" shall be centered below the system data. The system components shall be listed below the caption "Consisting of" in the same manner as the system data. AN type designations may be listed on the same line as the model and part numbers.

g. **Fleet readiness center notice <cfa>**. A notice, indicating the cognizant field activity responsible for the TM preparation, shall be included on the title page preceding the supersedure notice (e.g., "This manual prepared by NAVSURFWARCENDIV, Crane, IN, Code 8024.").

h. **Supersedure notice <super>**. When a manual is revised, a supersedure notice shall be placed below the end item nomenclature, designator, model, and/or part number(s). The notice shall always include the publication number and date, and if applicable, the revision number and date of the superseded manual (e.g., "This manual supersedes AE-172AA-720-100, dated 15 November 1978."). If a classified manual is being revised, the supersedure notice shall add the following statement: "which shall be destroyed in accordance with applicable security regulations."

i. **Cross-reference notices <suppl>**. When required, a cross-reference notice to supplements shall be placed below the supersedure notice or publication title.

j. **Continuation notice <continue>**. When a manual is divided into volumes, a continuation notice shall appear on the title page of each volume below the supersedure notice or publication title. The title page of each volume shall contain a statement that the applicable volume is incomplete without the other volume(s) of the set.

k. **Interim rapid action change (IRAC) <irac>**. A statement reflecting that IRACs have been incorporated into the TM.

l. **Distribution statement <distrib>**. All TMs shall have a distribution statement for each manual or revision, and it shall be placed above the authority notice. The appropriate distribution statement shall be provided by the requiring activity as selected from DoDI 5230.24.

(1) **Determination date**. The determination date shall be the date of the publication (basic or revision date, as applicable) when the distribution statement is applied.

(2) **Changed distribution statement**. If the distribution statement is changed, the determination date shall be the date of issue that effected the change.

MIL-STD-3001-1A(AS) w/CHANGE 1

APPENDIX B

m. Destruction notice <destr>. All TMs marked with distribution statements “B”, “C”, “D”, “E”, “F”, or “X” shall have a destruction notice provided by the requiring activity from DoDI 5230.24, and shall be placed directly below the distribution statement.

(1) For classified documents, follow the procedures in DoD 5220.22M, DoDM 5200.01-Volume 1, and SECNAV M-5510.36.

(2) For unclassified, limited documents, follow the procedures in DoDI 5230.24.

n. Third party agreement statement <thirdparty>. When a third party agreement statement is required on the title page of a TM, it shall be placed after the destruction notice. The appropriate third party agreement statement shall be provided by the requiring activity.

o. Export control warning <export>. All TMs with export controlled data shall be marked with the Export Control Warning provided by the requiring activity from DoDI 5230.24.

p. Authority notice <authnote>. The authority notice shall be centered directly below the destruction notice.

q. National stock number <nsn>. The national stock number (NSN) should be included immediately following the authority notice.

B.5.3.1.1.1 Title page - classified work package manuals. The title page of a classified manual shall show the classification of the equipment nomenclature as specified in DoD 5220.22M. The following additional data is applicable to classified manual title pages:

a. The security classification assigned by the requiring activity shall be placed on the top and bottom of the title page.

b. Classified text shall not appear on the last page of a classified manual. A blank page shall be furnished as the last page of a classified manual. The overall classification of the manual shall be placed at the top and bottom center of the back page.

c. Manuals classified Top Secret shall have the statement "This Publication consists of ___ Top Secret pages of ___ total pages. Copy No. ___ of ___ copies."

d. The applicable downgrading and declassification notation in accordance with DoD 5220.22M shall be placed at the bottom of the page below the classification marking. The notation shall be boxed.

B.5.3.1.1.2 Title and cover cards (Periodic Maintenance Requirements Card Set Decks only). A title card <titlecd> or cover card shall be prepared for all Periodic Maintenance Requirements Card (PMRC) decks. The format of the title card is shown in [figures |B-2](#), [|B-3](#), and [|B-4](#). The title page shall contain the following content information:

a. Publication number <tmidno>. The publication number assigned by the requiring activity shall be placed in the upper right corner of the card in large bold type. For Phase, QEC, ALSS and PSE cover cards, a 5/8-inch space measured from the top edge of the card down to the

MIL-STD-3001-1A(AS) w/CHANGE 1

APPENDIX B

top of the lettering shall be established to allow for drilling holes. The cover card shall not be numbered. It shall be printed on one side only.

b. Type of document. The words "CARD DECK" shall be centered in the upper portion of the card in large bold type.

c. Publication title <prtitle>. The publication title shall consist of the type of card deck and the end item nomenclature:

(1) Type of card deck <manualtype>. The type of card deck is a combination of the type(s) of coverage, if applicable, and functional element(s) contained in the card deck, e.g., "PHASED MAINTENANCE REQUIREMENTS CARD DECK," "DAILY INSPECTION CARD DECK," "DAILY INSPECTION/SERVICING CARD DECK" or other types of card decks, as identified in MIL-STD-3001-7. The type of card deck shall be centered on the card below the type of document in large bold type. For the Phase/QEC/ALSS card decks cover cards, identification shall be centered on the card as illustrated in [figure B-5](#). The PSE cover card shall show the PSE identification (type/model aircraft followed by "PECULIAR SUPPORT EQUIPMENT," nomenclature, and part number(s)) and shall be centered on the cover card as illustrated in [figure B-6](#). If the type equipment code is different from that listed on the card deck title card, then it, too, shall be included.

(2) End item nomenclature <sysnomen>. The end item nomenclature, such as the weapon system or equipment (including AN type designation), shall be centered below the type of card deck in large bold type. Spacing shall be determined by the number of additional items required on the title page. When applicable, the model(s) and part number(s) shall be placed below the nomenclature. The model(s) and part number(s) shall be in large bold type. If the card deck covers more than one model and/or part number and space considerations so dictate, the entries may be made in normal bold type, depending on the number of entries. For PSE PMRCs, the type/model of the applicable aircraft shall be followed by "PECULIAR SUPPORT EQUIPMENT."

d. Type equipment code <typeeqpcode>. The type equipment code shall be centered below the manufacturer's name on publications applicable to support equipment, peculiar support equipment (if applicable), surface or aerial targets, and airborne armament equipment or special stores.

e. Supersedure notice <super>. When a card deck is revised, a supersedure notice shall be centered below the end item nomenclature or type equipment code in normal bold type. The notice shall include the superseded publication number and its date plus all previously incorporated rapid action change numbers (e.g., "This card deck supersedes NAVAIR 17-600-117-6-2 dated 1 March 1980 through Change 2 dated 11 April 1981, including previously incorporated RACs 1 through 8."). The notice shall be deleted upon incorporation of the first change to the revised card deck. If a classified card deck is being revised, the supersedure notice shall add the following statement: "which shall be destroyed in accordance with applicable security regulations."

MIL-STD-3001-1A(AS) w/CHANGE 1

APPENDIX B

f. Interim rapid action change (IRAC) incorporation notice <irac>. A notice that an interim rapid action change (IRAC) has been incorporated, if applicable, shall be centered below the nomenclature or type equipment code (see [figure |B-2](#)).

g. Distribution statement <distrib>. The distribution statement shall be presented on all title cards as provided by the requiring activity as selected from DoDI 5230.24. The determination date shall be the date of the publication (basic, revision, change date, as applicable) when the distribution statement is applied. If the distribution statement is changed, the determination date shall be the date of the issue that effected the change.

h. Destruction notice <destr>. All card decks marked with distribution statements “B”, “C”, “D”, “E”, “F”, or “X” shall have a destruction notice provided by the requiring activity from DoDI 5230.24, and shall be placed directly below the distribution statement.

(1) For unclassified, limited documents, follow the procedures in DoDI 5230.24.

(2) For classified card decks, follow the procedures in DoD 5220.22M, DoDM 5200.01-Volume 1, and SECNAV M-5510.36.

i. Third party agreement statement <thirdparty>. When a third party agreement statement is required on the title card of a TM, it shall be placed after the destruction notice. The appropriate third party agreement statement shall be provided by the requiring activity.

j. Export control warning <export>. All card decks with export controlled data shall be marked with the Export Control Warning provided by the requiring activity from DoDI 5230.24.

k. Authority notice <authnote>. The publishing approval authority statement shall be presented in capital letters as follows:

"PUBLISHED BY DIRECTION OF THE COMMANDER, NAVAL AIR
SYSTEMS COMMAND"

l. Publication date <pubdate>. The publication (issue) date or revision date shall be placed in the lower right corner in large bold type. The right margin shall be aligned with that of the publication number. The publication date shall be the copy freeze date.

m. Change number <chgnum> and date <chgdate>. The change number and date, when applicable, shall be positioned below and aligned with the right margin of the issue or revision date. When the change is a formal RAC, the RAC number shall be included (see [figure |B-2](#)).

B.5.3.1.1.3 Checklist title page <fmcl>. The checklist title page (see [figure |B-7](#)) shall contain the following information:

a. Publication number <tmidno>. The publication number assigned by the requiring activity shall be placed in the upper right corner of the card.

MIL-STD-3001-1A(AS) w/CHANGE 1

APPENDIX B

b. Publication title <prtitle>. The publication title shall be centered below the publication number and consist of the following:

(1) Type of checklist. The type of checklist is a combination of the type(s) of coverage, if applicable, and functional element(s) contained in the manual, e.g., "TURNAROUND CHECKLIST," "PREOPERATIONAL CHECKLIST," or other types of checklists, as identified in MIL-STD-3001-7.

(2) End item nomenclature <sysnomen>. The end item nomenclature, such as the weapon system or equipment (including AN type designation), shall be centered below the type of checklist. When applicable, the model(s), and part number(s) shall be placed below the nomenclature. For SE preoperational checklists, when there are numerous items covered in the checklist and a type designator list is included in the checklist (refer to MIL-STD-3001-7), the statement "Refer to Type Designator List" may be placed below the overall nomenclature in lieu of listing each item by name and part number on the title page. For PSE checklists, the type/model of the aircraft applicable shall be followed by "PECULIAR SUPPORT EQUIPMENT."

c. Type equipment code <typeeqpcode>. The type equipment code shall be centered below the manufacturer's name on publications applicable to support equipment, peculiar support equipment (if applicable), surface or aerial targets, and airborne armament equipment or special stores.

d. Supersedure notice <super>. When a checklist is revised, a supersedure notice shall be centered below the end item nomenclature or type equipment code in normal bold type. The notice shall include the superseded publication number and its date plus all previously incorporated rapid action change numbers (e.g., "This checklist supersedes NAVAIR 17-600-117-6-2, dated 1 March 1980, through Change 2, dated 11 April 1981, including previously incorporated RACs 1 through 8.") (see [figure B-7](#)). The notice shall be deleted upon incorporation of the first change to the revised checklist. If a classified checklist is being revised, the supersedure notice shall add the following statement: "which shall be destroyed in accordance with applicable security regulations."

e. Interim rapid action change (IRAC) incorporation notice <irac>. A notice that an interim rapid action change (IRAC) has been incorporated, if applicable, shall be centered below the nomenclature or type equipment code.

f. Abbreviated distribution statement <distrib>. This statement shall be expressed as follows:

"DISTRIBUTION STATEMENT C. Distribution authorized to U.S. Government agencies and their contractors (*fill in reason*)(*date of determination*). Other requests for this document shall be referred to (*insert controlling DoD office*)."

MIL-STD-3001-1A(AS) w/CHANGE 1

APPENDIX B

g. Abbreviated destruction notice <destr>. This notice may be expressed as follows:

(1) For unclassified checklists:

"DESTRUCTION NOTICE - Destroy by any method that will prevent disclosure of contents or reconstruction of the document."

(2) For classified checklists:

"DESTRUCTION NOTICE - Follow procedures in SECNAV M-5510.36, Control of Classified Information."

h. Third party agreement <thirdparty>. When a third party agreement statement is required on the title page of a checklist, it shall be placed after the destruction notice. The appropriate third party agreement statement shall be provided by the requiring activity.

i. Export control warning <export>. All checklists with export controlled data shall be marked with the Export Control Warning provided by the requiring activity from DoDI 5230.24.

j. Authority notice <authnote>. The publishing approval authority statement shall be presented in capital letters as follows:

"PUBLISHED BY DIRECTION OF THE COMMANDER, NAVAL AIR SYSTEMS COMMAND"

k. Publication date <pubdate>. The publication (issue) date or revision date shall be placed in the lower right corner of the first page. The right margin shall be aligned with that of the publication number. The publication date shall be the copy freeze date.

l. Change number <chgnum> and date <chgdate>. The change number and date, when applicable, shall be positioned below and aligned with the right margin of the issue or revision date. When the change is a formal RAC, the RAC number shall be included (see [figure B-2](#)).

m. Introduction and application statement. An introduction and application statement, if applicable, shall follow the title page (see [figure B-7](#) and the introduction and application statement requirements in MIL-STD-3001-7).

B.5.3.1.2 Numerical index of effective work packages/pages (A page) <niewp>. A numerical index of effective WPs/pages shall be included for all manuals. When a manual is divided into volumes, each volume shall contain a numerical index of effective WPs/pages. The index for each volume shall include only the WPs/pages contained in the applicable volume. The "A" page shall back up the title page and shall be prepared as shown in [figure B-8](#).

B.5.3.1.2.1 List of current revisions. A list of current pickup revisions (designated as Change 1, Change 2, etc.) to the manual, including the basic issue or complete revision, shall be listed. The list of current revisions shall account for and include the numbers and dates of all rapid action changes (RACs) issued and all interim rapid action changes (IRACs) incorporated since the basic manual or its latest revision. All manual revisions shall reflect the cumulative status of all RACs

MIL-STD-3001-1A(AS) w/CHANGE 1

APPENDIX B

issued and incorporated. To maintain continuity of all issued RAC numbers, canceled RAC numbers, including those assigned but never issued, are to be included in the cumulative status of RACs incorporated.

B.5.3.1.2.2 List of effective cards <lecds> (Periodic Maintenance Requirements Card Set Decks only). A list of effective cards (see [figure B-9](#)) shall be prepared. This card shall back up the title card and shall be identified with the letter "A" in the lower left-hand corner. When additional space is required, "B", "C", etc., cards shall be added. The list of effective cards shall be a complete list of all cards, including the title card, "A" card, blank cards, deleted cards and added cards. The words "added," "deleted," or "blank" shall be placed alongside the cards so affected. Appropriate change numbers, including RAC numbers, shall be shown in the "Change No." column. A list of current changes to the card deck, including the basic issue or revision shall be identified by the word "Original", and the numeral "0" shall be listed. The list of current changes shall include the numbers and dates of all RACs incorporated since the basic card deck or its latest revision. The "A" card shall contain a statement confirming the total number of card faces in the card deck. A notice that an IRAC has been incorporated, if applicable, shall be inserted between the Note and the Dates of issue for original and changed cards.

B.5.3.1.3 Technical publication deficiency reports (TPDR) incorporated pages <tpdrpg>. A list of TPDRs incorporated shall be prepared for all revised manuals (see [figure B-10](#)). The TPDR list shall begin on the first right-hand page following the A-page (numerical index of effective WPs/pages). In multivolume sets, each volume shall contain a list of TPDRs incorporated for the volume.

B.5.3.1.3.1 Development of the technical publication deficiency reports incorporated. The list (**standard list**) shall reflect the data incorporated in the TM resulting from valid TPDRs. The "Identification No." column shall indicate the reporting activity and its TPDR file number. The "Location" column shall indicate the work package number (WP)/page number (pg)/paragraph number (p)/figure number (F)/table number (T), as appropriate, identifying the location in the manual where the data has been incorporated. The list shall reflect the data that has been incorporated in that particular issue. The list shall not be cumulative. The TPDR page shall be prepared at the first formal revision to the manual. If no TPDRs are to be incorporated, the word "None" shall be entered.

B.5.3.1.3.2 Technical publication deficiency reports (TPDR) incorporated cards (Periodic Maintenance Requirements Card Set Decks only). A list of TPDRs incorporated card **<tpdrcard>** (see [figure B-11](#)) shall be prepared for all changed/revised Periodic Maintenance Requirements Card Decks with the exception of 3 1/2" x 5 1/2" checklists and 5" x 8" single card checklists. The list (**standard list**) shall reflect the data incorporated in the card deck resulting from valid TPDRs. A double column format shall be used. Column headings shall be "Report Control Number (RCN)" and "Location." The RCN will be assigned by the reporting activity. Under the column heading "Location" the card number(s) shall be indicated as appropriate, identifying the location in the card deck where the data has been incorporated. The list shall reflect the data that has been incorporated in that particular issue. The list shall not be cumulative. The card(s) shall follow the List of effective cards ("A" card) and be numbered TPDR-1, TPDR-2, etc.

MIL-STD-3001-1A(AS) w/CHANGE 1

APPENDIX B

B.5.3.1.4 Hazardous Materials Warning Summary (HMWS) work package <hmwswp>. The complete warnings applicable to hazardous materials and related information shall be placed in the manual's front matter. The acronym "HMWS" (Hazardous Materials Warning Summary) shall be used to identify the warnings. The HMWS shall be placed in the manual starting on the first right-hand page following the A-page (initial issue of the TM) or TPDR pages (revised issue of the TM). The HMWS shall be prepared as shown in [figure |B-12](#).

B.5.3.1.4.1 Explanation of hazardous materials icons. Each of the nine authorized icons, with related explanation, shall be provided (see [figure |B-13](#)). Immediately following the explanation of the nine authorized icons, complete warnings shall be listed for all hazardous materials used in the manual. For multivolume sets, each volume shall contain a complete listing of the hazardous materials used in the multivolume set. The warnings shall be listed in the following manner:

a. Icons and material. Provide all applicable icons above the hazardous material's nomenclature and applicable specification.

b. Index number. Assign the hazardous material warning Arabic numeral identifier; either the manual's sequentially assigned index number or the contractor's database permanent numeric identifier as outlined below:

(1) Sequentially assigned numbers. Starting with the number 1, the warnings shall be sequentially numbered. Each hazardous material shall be assigned only one numeric identifier. Repeated use of a specific hazardous material shall reference the numeric identifier assigned at its initial appearance. Warnings added to the TM after the initial issue shall be assigned the next consecutive number regardless of the order of placement in the manual.

(2) Contractor-assigned numbers. Contractors having an automated publishing system may assign permanent numeric identifiers for hazardous materials warnings in their database. When contractor-assigned numbers are used, the introduction to the manual shall explain that the numeric identifiers may not appear in sequential order, since all warnings contained in the database may not appear in the manual.

c. Warning. Enter complete warning with appropriate personnel protective equipment requirements.

d. Multivolume set notation. If applicable, a note shall be placed at the bottom of the first page of the list of hazardous material warnings stating that not all numbered warnings may appear in all volumes of the manual.

e. Contractor's index number notation. If applicable, a note shall be placed at the bottom of the first page of the list of hazardous material warnings stating that the missing index numbers are not applicable to this manual.

B.5.3.1.4.2 Warnings applicable to hazardous materials card (HMWS card) (Periodic Maintenance Requirements Card Set Decks only). Hazardous material warning cards <hmwscard> (see [figure |B-14](#)) shall be prepared for all hazardous materials addressed in the card deck (not to include checklists). The cards shall be titled "WARNINGS APPLICABLE TO

MIL-STD-3001-1A(AS) w/CHANGE 1

APPENDIX B

HAZARDOUS MATERIALS" and shall be placed in the card deck immediately following the TPD card and shall be numbered in consecutive order, i.e., HMWS-1, HMWS-2, HMWS-3, etc.

- a. The following introductory paragraphs shall be verbatim as expressed below:

INTRODUCTION

"Warnings for hazardous materials listed in this manual are designed to warn personnel of hazards associated with such items when they come in contact with them by actual use. Additional information related to hazardous materials is provided in DoD 6050.05, OPNAVINST 5100.23, OPNAVINST 5100.19, and OPNAVINST 5090.1. For each hazardous material used within the Navy, a Material Safety Data Sheet (MSDS) must be available for review by users in Hazardous Materials Information Resource System (HMIRS). Consult your local safety and health staff concerning any questions on hazardous chemicals, MSDS, personal protective equipment requirements, and appropriate handling and emergency procedures and disposal guidance."

"Complete warnings for hazardous materials referenced in this card deck are identified by use of an icon, nomenclature, specification or part number of the material, and a numeric identifier. The numeric identifiers have been assigned to the hazardous materials in the order of their appearance in the card deck. Each hazardous material is assigned only one numeric identifier. Repeated use of a specific hazardous material references the numeric identifier assigned at its initial appearance. Warnings added to the card deck after the initial issue will be assigned the next consecutive number regardless of its placement in the card deck."

"In the text of the card deck, the WARNING caption will not be used for hazardous materials. Such warnings will be identified by an icon and numeric identifier. The material nomenclature will also be provided. The user is directed to refer to the corresponding numeric identifier listed below for the complete warning applicable to the hazardous material."

- b. Complete warnings shall be provided for all hazardous materials addressed in the card deck. The caption "HAZARDOUS MATERIALS WARNINGS" shall be centered on the first full page following the introductory paragraphs. The column headings "Index," "Material," and "Warning" shall appear below the caption (see [figure B-14](#)).

B.5.3.1.4.2.1 Hazardous materials referenced in text. In the text of the card deck (not to include checklists), the WARNING caption shall not be used for hazardous materials. Such warnings shall be identified by an icon, nomenclature of the material and a numeric identifier (see example of a task card in MIL-STD-3001-7). Complete warnings for each hazardous material shall be provided on the HMWS cards.

B.5.3.1.5 Alphabetical index work package <alphaindxwp>. The alphabetical index WP shall be the first WP and shall begin on the first right-hand page following the HMWS. This WP shall

MIL-STD-3001-1A(AS) w/CHANGE 1

APPENDIX B

be assigned WP number 001 00. The primary purpose of this index is to provide access to the technical content WPs contained in the manual and further to the primary technical content information contained within each WP (see [figure B-15](#)).

B.5.3.1.5.1 Development of the alphabetical index work package. The primary consideration in the development of the alphabetical index shall be the accessibility of the data. Entries shall be listed as follows:

a. WP end item's nomenclature. Each WP contained in the manual shall be listed by nomenclature and the applicable WP number. The WP end item's nomenclature shall be identical with the WP title block, except for arrangement of wording.

(1) Nomenclature for the assembly/subassembly shall be arranged with the noun name preceding the modifiers; e.g., "Power Driven Rotary Vacuum Pump" shall be listed as "Pump, Rotary, Vacuum, Power Driven."

(2) Nomenclature shall also be listed under significant modifiers as functional task or element cross-reference entries, e.g., "Vacuum Pump, Rotary, Power Driven."

(3) "AN" nomenclature shall not be used as a main entry, but shall be used as a subordinate (cross-reference entry); e.g., "Mount, Antenna, Coupler, UHF, MT-1995/A (34A1)" shall be listed as "MT-1995/A UHF Antenna Coupler Mount (34A1)."

(4) WP end item's reference designation shall not be used as a main entry, but shall be listed following applicable entries to improve access to data. This is extremely critical when more than one item has similar nomenclature.

b. Additional alphabetical index entries. The content of each WP shall be entered under the primary WP nomenclature. Content to be listed shall include, but not be limited to system, subsystem, equipment, and component name entries and each supporting information and maintenance task included in the WP. These subordinate content listings shall be listed alphabetically. For each entry, the WP number and page that the information can be found on shall be included.

c. Effectivity notice. The effectivity shall be listed as a subordinate entry when the same basic item is covered in more than one WP by effectivity (e.g., **EFFECTIVITY: Engine Serial No. 216001 and Subsequent**).

B.5.3.1.6 Alphabetical index work package <alphaindxwp> for multivolume TMs. When a TM is divided into volumes due to its thickness, the first volume of the set shall include a complete alphabetical index WP for the entire set. The primary purpose of this index is to provide access to the technical content WPs contained in all the volumes in the set. The alphabetical index WP content requirements are identical to those described in [B.5.3.1.5](#) and [B.5.3.1.5.1](#) except that a publication number column is required (see [figure B-16](#)). The alphabetical index WP for each subsequent volume of a multivolume set shall list only the WPs contained in the applicable volume, and the WP and the content requirements shall be identical to those described in [B.5.3.1.5.1](#) (see [figure B-15](#)).

MIL-STD-3001-1A(AS) w/CHANGE 1

APPENDIX B

B.5.3.2 Supporting information. Supporting information shall be logically subdivided into the support-oriented WPs that are required to supplement or complement the technical information and task-oriented WPs developed in accordance with this standard. The format and content requirements for supporting information are contained in [B.5.3.2.1](#) through [B.5.3.2.1.3.5](#).

B.5.3.2.1 Work package content. Each WP developed for supporting information shall consist of the following:

- a. Title block.
- b. Required technical support information.

B.5.3.2.1.1 Title block <titleblk>. The title block (see [figure |B-17](#)) shall contain the following data:

a. **Work package title <wptitle> data.** The WP title block shall contain the following title information:

(1) **Maintenance levels <maintlvl>.** The maintenance level(s) shall be stated (e.g., "INTERMEDIATE AND DEPOT").

(2) **WP general title <subject>.** The title shall describe the general subject or maintenance task and follow the maintenance level (e.g., "NUMERICAL INDEX OF PART NUMBERS"). For **Fault Isolation Manuals only**, the specific symptom or malfunction shall be used in lieu of a general subject or maintenance task.

(3) **End item nomenclature <sysnomen>.** The end item nomenclature such as the system, subsystem, or equipment (including AN type designation), shall follow the WP general title. When applicable, the model(s) and part number(s) shall be placed below the nomenclature. When the WP covers more than one model and/or part number, all models and/or part numbers shall be listed.

b. **Effectivity notice <effect>.** If applicable, an effectivity notice shall be included in the title block.

c. **Supersedure notice <super>.** If applicable, a supersedure notice shall be placed below the effectivity notice. If the WP supersedes a WP in the same manual, the supersedure notice shall be as follows: "This WP supersedes (*WP number*), (*date*)."
If the superseded WP is contained in another manual, the notice shall include the publication number as follows: "This WP supersedes (*WP number*), (*date*), contained in (*publication number*)."
If an unclassified or classified WP supersedes a classified WP, the notice shall be as follows: "This WP supersedes (*WP number*), (*date*), which shall be destroyed in accordance with applicable security regulations."

d. **Cross-reference notice <suppl>.** If applicable, cross-reference notes to supplements shall be included (e.g., "This WP is incomplete without WP 042 00 contained in confidential supplement, NAVAIR 16-30XYZ-20").

MIL-STD-3001-1A(AS) w/CHANGE 1

APPENDIX B

B.5.3.2.1.2 Fault isolation title block <fititleblk>. For **Fault Isolation Manuals only**, the title block (see [figure B-17](#)) shall contain the following data:

a. Work package title <wptitle> data. The WP title block shall contain the following title information:

(1) Maintenance levels <maintlvl>. The maintenance level(s) shall be stated (e.g., "INTERMEDIATE AND DEPOT").

(2) WP general title <subject>. The title shall describe the general subject or maintenance task and follow the maintenance level (e.g., "TROUBLESHOOTING PROCEDURE"). For **Fault Isolation Manuals only**, the specific symptom or malfunction <trblshtsym> shall supplement the subject.

(3) End item nomenclature <sysnomen>. The end item nomenclature, such as the system, subsystem, or equipment (including AN type designation), shall follow the WP general title. When applicable, the model(s) and part number(s) shall be placed below the nomenclature. When the WP covers more than one model and/or part number, all models and/or part numbers shall be listed.

b. Effectivity notice. If applicable, an effectivity notice shall be included in the title block.

c. Supersedure notice <super>. If applicable, a supersedure notice shall be placed below the effectivity notice. If the WP supersedes a WP in the same manual, the supersedure notice shall be as follows: "This WP supersedes (*WP number*), (*date*).". If the superseded WP is contained in another manual, the notice shall include the publication number as follows: "This WP supersedes (*WP number*), (*date*), contained in (*publication number*).". If an unclassified or classified WP supersedes a classified WP, the notice shall be as follows: "This WP supersedes (*WP number*), (*date*), which shall be destroyed in accordance with applicable security regulations."

d. Cross-reference notice <suppl>. If applicable, cross-reference notices to supplements shall be included (e.g., "This WP is incomplete without WP 042 00 contained in confidential supplement, NAVAIR 16-30XYZ-20").

B.5.3.2.1.3 Required technical support information. All WPs described in [B.5.3.2.1.3.1](#) through [B.5.3.2.1.3.5](#) may include some general explanatory information about the content of the WP. Technical support information shall be developed and divided into the following types of WPs:

- a. Numerical index of part numbers WP.
- b. Numerical index of reference designations WP.
- c. Introduction WP.
- d. Consolidated lists for technical directives, support equipment, materials, and references WP.

MIL-STD-3001-1A(AS) w/CHANGE 1

APPENDIX B

e. Maintenance allocation WP (**engine intermediate maintenance only**).

f. Safety summary WP, as applicable (**training systems only**).

B.5.3.2.1.3.1 Numerical index of part numbers work package <partnoindxwp>. This WP shall contain a complete list (**standard list**) of part numbers consolidated from all maintenance WPs containing group assembly parts lists (GAPLs) (see [figure B-18](#)). This WP shall be assigned WP number 001 01. In multivolume sets, the first volume of the set shall include a complete numerical index of part numbers WP for the entire set. Each subsequent volume shall contain a numerical index of part numbers WP for the volume. The primary purpose of this index is to provide direct access to the maintenance WP and figure related to a specific part number. The heading "NUMERICAL INDEX OF PART NUMBERS" shall appear in the title block of this WP. The list shall be prepared as described below:

a. For all maintenance manuals, parts contained in the maintenance WP GAPLs shall be listed by "PART NUMBER" and "WP/FIGURE/INDEX NUMBER."

b. For all maintenance manuals with an IPB divided into volumes, parts contained in the GAPLs shall be listed by "PART NUMBER," "VOLUME," and "WP/FIGURE/INDEX NUMBER." A sufficient portion of the publication number of the manual/volume in which each part number listed appears shall be identified. For example, if the publication number of the first manual is A1-F18AA-110-100 and the second manual is numbered A1-F18AA-120-100, only the numbers 110-100 and 120-100 would be listed. If the first volume is numbered A1-610AA-IMM-010 and the second volume is numbered A1-610AA-IMM-020, only the numbers 010 and 020 would be listed. The method of identification shall be explained in the applicable introduction.

c. All part numbers listed in the GAPL part number column of every IPB figure contained in the maintenance WPs shall be listed except for attaching parts. Attaching parts may be listed but are not mandatory. Superseded parts that have continued application shall be listed. Part numbers shall be listed in alphanumeric sequence as follows:

(1) First position of the part number in order of precedence: the letters A through Z, the numerals zero through nine.

(2) Second and succeeding positions of the part number in order of precedence, from left to right: space (blank position), diagonal (/), point (.), dash (-), letters A through Z, and numerals zero through nine.

(3) Items without part numbers (listed with a dash (-) in the GAPL part number column) shall be listed alphabetically, using the identifying noun in lieu of a part number.

d. The diagonal lines (/) in "WP/FIGURE/INDEX NUMBER" are used to separate the entries. When more than one entry is required for a part number, the entries shall be listed in the following order of precedence: WP number, figure number, and index number. When the entry is for the IPB figure's end item, the index number shall be left blank. Each entry shall list the WP

MIL-STD-3001-1A(AS) w/CHANGE 1

APPENDIX B

number first, followed by a diagonal line, the figure number second, followed by a diagonal line, and the index number.

B.5.3.2.1.3.2 Numerical index of reference designations work package <refdesindxwp>. This WP shall contain a complete list (**standard list**) of reference designations consolidated from all maintenance WPs containing GAPLs (see [figure B-19](#)). This WP shall be assigned WP number 001 02. In multivolume sets, the first volume of the set shall include a complete numerical index of reference designations WP for the entire set of volumes. Each subsequent volume shall contain a numerical index of reference designations WP for the volume. The primary purpose of this index is to provide direct access to the maintenance WP and figure related to a specific reference designation. The heading "NUMERICAL INDEX OF REFERENCE DESIGNATIONS" shall appear in the title block of this WP. The list shall be prepared as described below:

NOTE

If an existing legacy wire repair TM is being converted to XML and the format and packaging is retained, an option is provided to include a wire reference designation to work package index (**standard table**) in lieu of the numerical index of reference designations. All reference designations contained in the wire list shall be listed in the optional index by "REFERENCE DESIGNATION," "WORK PACKAGE NUMBER", and "ASSEMBLY IDENTIFICATION". For TMs divided into volumes, all reference designations contained in the wire list shall be listed in the optional index by "REFERENCE DESIGNATION," "VOLUME NUMBER," "WORK PACKAGE NUMBER," and "ASSEMBLY IDENTIFICATION."

a. All parts listed with a reference designation contained in the maintenance WP GAPLs shall be listed by "REF DES," and "WP/FIGURE/INDEX NUMBER." The entry "USABLE ON CODE" may be added (refer to [B.5.3.2.1.3.2 c. \(3\)](#)) if required.

b. For all maintenance manuals with an IPB divided into volumes, all parts listed with a reference designation in the GAPLs shall be listed by "REF DES," "VOLUME," and "WP/FIGURE/INDEX NUMBER." A sufficient portion of the publication number of the manual/volume in which each part number listed appears shall be identified. For example, if the publication number of the first manual is A1-F18AA-110-100 and the second manual is numbered A1-F18AA-120-100, only the numbers 110-100 and 120-100 would be listed. If the first volume is numbered A1-610AA-IMM-010 and the second volume is numbered A1-610AA-IMM-020, only the numbers 010 and 020 would be listed. The method of identification shall be explained in the applicable introduction.

c. Reference designations shall be listed in reference designation sequence.

(1) Multiple identical assemblies (same reference designations). When multiple reference designations apply to the same IPB figure (e.g., circuit card assembly), all detail part reference designations shall be listed in the first WP that they appear.

MIL-STD-3001-1A(AS) w/CHANGE 1

APPENDIX B

(a) Second and subsequent items may reference the first item to reduce unnecessary redundant entries in the index.

(b) The second and subsequent reference designations shall reference the end item breakdown figure and reference the first related item, e.g., "BKDN same as A3" or "See A3 for BKDN."

(2) Multiple end items. When more than one unit is covered by one manual, a unit reference designation shall be assigned or the same reference designation may apply to subassemblies of different end items.

(3) Effectivity difference. When a reference designation applies to more than one IPB figure (e.g., effectivity difference), a "USABLE ON CODE" may be added to the index. An explanation of the "USABLE ON CODE" application and usage shall be added to the WP. When usable on codes are used, the "USABLE ON CODE" entry shall be contained on all index pages. When figure-specific usable on codes are used in different IPB figures, a modified coding shall be used for this index.

d. The diagonal lines (/) in "WP/FIGURE/INDEX NUMBER" are used to separate the entries. When more than one entry is required for a reference designation, the entries shall be listed in the following order of precedence: WP number, figure number, and index number. When the entry is for the IPB figure's end item, the index number shall be left blank. Each entry shall list the WP number first, followed by a diagonal line, the figure number second, followed by a diagonal line, and the index number.

B.5.3.2.1.3.3 Introduction work packages <introwp>. An introduction shall be developed for all TMs. The primary purpose of the introduction is to provide information necessary to use the data provided in the TM and respective WPs as effectively as possible. The heading "INTRODUCTION" shall appear in the title block of this WP. The introduction WP shall include the following information, as applicable:

a. Purpose and scope <intropara>. The purpose and scope of the manual, including the subject matter being covered.

b. Description and designated nomenclature <intropara>. The designated nomenclature and a brief description of the end item. The introduction shall not include an illustration of the equipment.

c. Requisitioning and automatic distribution of NAVAIR technical publications <intropara>. The following statement relative to requisitioning and automatic distribution of NAVAIR technical publications shall be included:

"Procedures to be used by naval activities and other Department of Defense activities requiring NAVAIR TMs are defined in NAVAIR 00-25-100."

Additional information such as how to automatically receive future revisions and to order replacement or additional copies shall also be included.

MIL-STD-3001-1A(AS) w/CHANGE 1

APPENDIX B

- d. Manual issue date <intropara>. An explanation of the manual issue date.
- e. Effectivity information. If applicable, an explanation of the effectivities used throughout the TM may be included in a consolidated list of effectivity information <consoleffectlist> (**standard table**). A standard table shall be used to indicate configuration (effectivity) differences. If used, the standard table shall include an Effectivity Legend <effectlegend> column containing the legend that will be used throughout the WP text to consolidate or shorten the configuration identification. The legend shall use usable on code letters or numbers <effectcode> and shall appear within a box. In lieu of boxed letters or numbers, a graphic representation may be used to represent effectivity. Do not combine more than one number or letter in a legend box unless it results in significant page reduction. The second column, Configuration Identification <config>, shall list the actual configuration represented by the legend, such as tail numbers, BuNos, model numbers, serial numbers, part numbers, technical directive numbers, etc., covered by the TM. The third column, **Remarks <remarks>**, shall be a column required for any relative information about the configuration data, such as an ECP or AVC incorporated.
- f. Technical directives <intropara>. An explanation and purpose of technical directives.
- g. Technical publications deficiency report (TPDR) <intropara>. An explanation and purpose of the TPDR.
- h. Quality assurance requirements and highlighting techniques <intropara>. If applicable, an explanation of the quality assurance requirements and methods of highlighting QA provisions (refer to [B.5.4.7.3](#)).
- i. Support equipment availability statement <intropara>. If applicable, the statement "When an item of support equipment is not available, an approved alternate identified in the activity's Individual Material Readiness List (IMRL) may be substituted." shall be included.
- j. Abbreviations, symbols, new and unusual terms <intropara>. An explanation of the abbreviations, symbols, and new and unusual terms used in the WPs and not included in COMNAVAIRFORINST 4790.2 (e.g., LOX, QEC, MAG, HCP, HCI, ESD, etc.) shall be included.
- k. Safety precautions <intropara>. If applicable, a reference to other documents containing general safety precautions and an explanation of specific safety precautions used throughout the WPs.
- l. Nuclear Survivability Requirements <intropara>.
- (1) The introduction shall include an explanation of the pertinent information as necessary to emphasize uniqueness of Hardness Critical Items (HCI), and shall include the [HCI] symbol's usage and method of highlighting.
 - (2) The introduction shall include a caution statement explaining that the symbol establishes the requirement that all paragraphs and processes/steps in the WPs and items in the

MIL-STD-3001-1A(AS) w/CHANGE 1

APPENDIX B

GAPL identified by the symbol shall be followed as written to ensure nuclear hardness is not degraded.

m. Electrostatic discharge (ESD) sensitive parts <intropara>.

(1) The introduction shall include an explanation of the [ESD] symbol's usage and method of highlighting and other pertinent information as necessary to emphasize uniqueness of ESD sensitive components.

(2) The introduction shall include a caution statement explaining that the symbol establishes the requirement that all paragraphs and processes/steps in the maintenance WPs and items in the IPB identified by the symbol shall be followed as written to ensure ESD sensitive components are not degraded. The caution shall reference COMNAVAIRFORINST 4790.2 for standard maintenance practices and handling procedures and precautions.

n. Warnings, cautions, and notes <intropara>. An explanation of the use of warnings, cautions, and notes.

o. Other specific introductory information <intropara>. Additional introductory information related to a specific type of TM shall be included, as necessary.

p. How to use the manual <how-to-use-etm>. When necessary, an explanation of how to use the manual and how the manual is used with other manuals shall be provided. When authoring the introduction WP narrative, and it is expected that the publication will be used as an IETM as well as page-based, tailor the explanation as applicable. (Refer to Appendix C, [C.5.3.5](#) for IETMs.)

B.5.3.2.1.3.3.1 Introductory information for structural repair, corrosion control, and nondestructive inspection information. In addition to the introduction information contained in [B.5.3.2.1.3.3](#), the following additional introductory information shall be developed for structural repair, corrosion control, and nondestructive inspection information:

a. Terms <intropara>. Definitions for commonly used structural repair, corrosion control and nondestructive methods, symbols, and repair terms of a general nature.

b. Damage evaluation <intropara> (structural repair information only). Information on how to evaluate damage to structural areas.

c. Installation procedure symbols <intropara> (structural repair information only). Symbols used in skin, structural, and fastener indexes and repair and replacement procedures shall be explained and illustrated.

d. Dimensions <intropara>. An explanation of the use of dimensions and tolerances.

e. Nondestructive inspection (NDI) methods <intropara> (NDI information only). An explanation of NDI methods which may be applied to structure, parts, or material to determine its integrity without causing change in any of its physical characteristics.

MIL-STD-3001-1A(AS) w/CHANGE 1

APPENDIX B

B.5.3.2.1.3.3.2 Introductory information for testing and troubleshooting procedures. In addition to the introductory information contained in [B.5.3.2.1.3.3](#), the following additional introductory information shall be developed for all manuals containing testing and troubleshooting procedures:

a. Test procedures <intropara>. An explanation of how the test procedures are structured and how they are to be used in conjunction with the troubleshooting procedures.

b. Troubleshooting procedures <intropara>. An explanation of scope and how the troubleshooting procedures are structured and how they are to be used in conjunction with the testing procedures.

B.5.3.2.1.3.3.3 Introductory information for illustrated parts breakdown (IPB) data. All manuals containing WPs with one or more IPB figures shall include an explanation of the IPB listings and figures. The IPB explanation shall follow all other introductory information in the introduction WP ([B.5.3.2.1.3.3](#), [B.5.3.2.1.3.3.1](#) and [B.5.3.2.1.3.3.2](#)), except "How to use the manual." The IPB explanation shall include, but not be limited to, the following:

a. Joint Service requirements <intropara>. Complete identifying information is required if the IPB is to be used by another service that designates the end item by its own type, model or serial numbers.

b. Index Number entry <intropara>. Explain the sequencing of index numbers and their use in the IPB illustration.

c. Part Number entry. Explain the meaning of a dash (-) or "COML."

d. Description entry. Explain the following entries, if applicable:

(1) Indention to show relationship, numbers and leaders (periods).

(2) Preceding symbols (e.g., [HCI] or [ESD]).

(3) Manufacturer's code.

(4) Any "make-from" parts shall include specific part number and source for the source stock item.

(a) Appearance in listing, including suppression of the Government and/or prime contractor's codes. When the prime contractor's code is suppressed, the code shall be identified in the introduction.

(b) Reference shall be made to the H-4/H-8 catalog series for detailed information.

(5) Conditional acronym or abbreviation (e.g., LOX/QEC/MAG).

(6) Method of listing attaching parts.

MIL-STD-3001-1A(AS) w/CHANGE 1

APPENDIX B

- (7) Parts kits. Method of listing, including indention.
- (8) Amplifying information.
- e. Units per assembly entry. Any unusual entries.
- f. Usable on code entry. Application and Alternate/Equivalent/Redesigned parts.
- g. Source, maintenance, and recoverability (SM&R) codes <intropara>. An explanation of SM&R codes, with an appropriate supporting illustration, shall be included. Reference to the specific issue of the NAVAIR instruction to which the end item was provisioned shall be made. Explain the method of provisioning used for multiple applications of identical parts and the specific impact on the listed SM&R codes (e.g., first occurrence coding). In addition, the NAVICP P2300 series publications shall be cited as the source for the most current SM&R codes listed in an IPB, and if different than the manual, the manual requires an update to reflect any related maintenance instructions.
- h. Numerical indexes of part numbers and reference designations <intropara>. An explanation, including how to use the numerical index of part numbers and reference designations.

B.5.3.2.1.3.3.4 Introductory information for illustrated parts breakdown (IPB) manuals. All IPB manuals and all multi-volume IPB manuals shall have an introduction. The introduction shall consist of the applicable requirements described in [B.5.3.2.1.3.3](#) and [B.5.3.2.1.3.3.3](#).

B.5.3.2.1.3.4 Consolidated lists for technical directives, support equipment, materials, and references work package <consolistwp>. This WP shall contain a historical list of applicable technical directives and consolidated lists for support equipment required, materials required, and references (see [figure |B-20](#)). The heading "CONSOLIDATED LISTS FOR TECHNICAL DIRECTIVES, SUPPORT EQUIPMENT, MATERIALS, AND REFERENCES" shall appear in the title block of this WP. The data required for these lists are provided in [B.5.3.2.1.3.4.1](#) through [B.5.3.2.1.3.4.4](#).

B.5.3.2.1.3.4.1 Historical record of applicable technical directives <hrtad>. A consolidated historical list of the technical directives (**standard list**) applicable to all WPs shall be prepared. The historical record of technical directives shall be prepared in accordance with the following guidelines:

- a. An introduction shall precede the listings and shall include an explanation of the historical record of technical directives listing entries.
- b. A statement that approved technical directives affecting a specific WP shall be listed at the beginning of the applicable WP shall also be included.

MIL-STD-3001-1A(AS) w/CHANGE 1

APPENDIX B

c. The following entries are applicable for all technical directives and related engineering change proposals (ECPs) or Rapid Action Minor Engineering Changes (RAMEC):

(1) "TD Type/No." - Enter the type and number of the technical directive, e.g., "F/A-18 AFC 126" or "AVC 102."

NOTE

The "TD Type/No." is identified on the Change Control Board (CCB) formal letter of ECP or RAMEC approval. Refer to NAVAIR 00-25-300.

(2) "TD Date" - Enter the date of issue of the technical directive. If the number of the technical directive has been assigned but the directive has not been issued, a dash (-) shall be entered.

(3) "Title and ECP/RAMEC No." - The title of the technical directive and ECP number or RAMEC, if applicable, shall be listed. If a technical directive listed is the direct result of an approved ECP or RAMEC, the acronym ECP or RAMEC and number shall be shown in parentheses following the technical directive title.

(4) "Date Inc." - The date the information affected by the technical directive or the ECP was incorporated into the WP.

(a) If the technical directive number has been assigned and the directive has not yet been issued (retrofit program), but the ECP that incorporates the change in the production program has been approved, the production ECP coverage shall be included, and the notation "Production coverage only" shall be entered under "Remarks."

(b) When the retrofit TD is approved and incorporated in a change or revision following the incorporation of the production ECP coverage, the TD date of issue shall be entered under "TD Date," the notation "Production coverage only" shall be removed from under "Remarks," and the date of retrofit coverage incorporation shall be listed under "Date Inc." (in lieu of the production ECP coverage incorporation date).

(5) "Remarks" - Enter any applicable remarks.

B.5.3.2.1.3.4.2 Consolidated list of support equipment required <sereq>. A list of support equipment and special tools required (**standard list**) to perform the operational checkout, troubleshooting, and maintenance procedures contained in all WPs shall be prepared. The list shall be prepared in accordance with MIL-STD-3001-4 and the following additional requirements:

a. Total quantity. The total quantity is not applicable to the consolidated list of support equipment.

b. Alternate items. If an alternate item can be used, it shall be listed below the prime item to which they apply and shall be indented.

MIL-STD-3001-1A(AS) w/CHANGE 1

APPENDIX B

- (1) Alternate item nomenclature is not required to match the prime item.
- (2) The term "or equivalent" shall not be used to identify alternate part numbers.
- (3) The requirement to list alternates shall not be interpreted to mean the preparing activity shall perform research to include such alternates.
- (4) If information on an equivalent item is passed to the preparing activity for inclusion in the WPs, the item shall be listed as required above.

B.5.3.2.1.3.4.3 Consolidated list of materials required <matreq>. A list of all materials (consumable materials and/or expendable items) (**standard list**) required to perform maintenance type procedures contained in all WPs shall be prepared. The list shall be prepared in accordance with MIL-STD-3001-4, except the total quantity is not applicable to the consolidated list of materials required.

B.5.3.2.1.3.4.4 Consolidated list of reference material <refmat>. A complete list of reference material (**standard list**) consolidated from all technical content WPs shall be prepared. The list shall be prepared in accordance with MIL-STD-3001-4, except references to WPs in the same manual shall not be included.

B.5.3.2.1.3.5 Maintenance allocation work package <maintalwp> (engine intermediate maintenance only). This WP shall include identification of tasks applicable to each degree of intermediate maintenance for the engine and its assemblies and components. A table (**standard table**) shall be developed identifying "1st," "2nd," and "3rd" for each degree of intermediate maintenance (see [figure B-21](#)). The WP shall also include an explanation of the maintenance allocation headings and a statement that allowable maintenance shall be consistent with spare parts provisioning, support equipment and maintenance site capability, and that if these conditions are not met, the engine shall be declared beyond capability of maintenance (BCM) and shall be transferred to a maintenance activity having repair capability in accordance with COMNAVAIRFORINST 4790.2.

B.5.3.2.1.3.6 Safety summary work package <safewp> (training systems only). When required, a safety summary WP shall be prepared for TMs containing warnings and cautions. The safety summary is not a word-for-word repetition of all the precautions in the TM and should be limited to alerting the user of the different types of hazards, in general terms, that will be encountered in operating and maintaining the training system or equipment covered within the TM.

B.5.4 Style and format guidelines. The technical writing style and format guidelines provided in [B.5.4.1](#) through [B.5.8](#) are considered mandatory and are intended for compliance. The requirements contained herein shall be followed to ensure that the conforming DTDs can be used to develop digital data. Additional graphics preparation guidance is contained in [Appendix D](#).

B.5.4.1 Printed manuals. When manuals are intended to be printed and distributed on paper, the guidelines contained in [B.5.4.1.1](#) through [B.5.4.1.4](#) shall be followed.

MIL-STD-3001-1A(AS) w/CHANGE 1

APPENDIX B

B.5.4.1.1 Page size of reproducible copy. Table I lists the page sizes authorized for use in manuals prepared to this specification (see [figure B-22](#)). When authorized by the requiring activity, a page size of 3 x 5 inches for turnaround and preoperational checklists may be used.

B.5.4.1.2 Image area of reproducible copy. The image area (including marginal copy) for approved page sizes is provided in Table B-I. When authorized, the image area for a 3 x 5 inch page is 2 1/2 x 4 1/2 inches. The maximum printing area includes all printed matter on the page (e.g., text, illustration, revision bars, TM numbers, page numbers, etc.).

TABLE B-I. TM page sizes (in inches).

Style	Trim Size	Format	Maximum Printing Area
Standard	8 1/2 x 11	Vertical	7 x 10
	11 x 8 1/2	Horizontal	10 x 7
PMRCs (Phased Maintenance Requirements Cards)	5 x 8	Horizontal	4 x 6 1/4
	17 x 11		
Double		Horizontal Only	15 1/2 x 10

B.5.4.1.3 Authorized printed manual size by thickness. The thickness of a printed copy shall not exceed the following limits:

<u>Page Size</u> (Inches)	<u>Thickness</u> (Inches)	<u>Approximate Sheet Count</u> (Sheets of Paper)
8 1/2 x 11	3	750
17 x 11	1	150 (Heavy Stock Paper)

A manual that exceeds the above limits shall be subdivided into volumes.

For PMRCs prepared on heavy stock, there are no thickness limitations.

B.5.4.1.4 Table B-II lists manual trim sizes, foldout maximum page trim sizes, and foldout maximum image area for foldout pages. The minimum margin is 1/2-inch top and bottom and 1/2-inch on the side opposite the binding edge. Binding edge margin shall not be less than one inch. Foldouts shall only appear in 8 1/2 x 11 manuals.

MIL-STD-3001-1A(AS) w/CHANGE 1

APPENDIX B

TABLE B-II. Foldout page sizes (in inches).

Maximum Trim Size	Foldout Maximum Page Trim Size (Including Apron)	Foldout Maximum Image Area
8 1/2 x 11	45 x 11	36 x 10

B.5.4.2 Type sizes and styles. Table B-III lists preferred type sizes and styles. All type sizes may be plus or minus one point. Slight variations in spacing and leading are permitted. Except for pocket size TMs that may use 6-point type size, 8 point is the smallest permissible type size.

TABLE B-III. Style, capitalization, leading, and spacing.

Use	Preferred Type/Size	Capitalization	Leading	Vertical Spacing
Title Page: Security Classification	Same or larger than TM number	Upper case		
Title Page: TM Number	Sans serif bold 18-20	Upper case		
Title Page: Publication or Revision Number and Date	Sans serif bold 14	Initial caps		
Title Page: Technical Manual	Sans serif bold 14	Upper case		
Title Page: Type of Publication	Sans serif bold 18	Upper case		
Title Page: Maintenance Levels	Sans serif bold 18	Upper case		
Title Page: Nomenclature of Equipment	Sans serif bold 18-20	Upper case		
Title Page: Type, Model, Part Number, National Stock Number, or Subject	Sans serif bold 14-18	Upper case		
Title Page: Subtitle (Volume Title and Number)	Sans serif bold 14	Upper case		
Title Page: Supersedure Notice, Cross-reference Notice, Continuation Notice	Sans serif bold 10	Upper and lower case		
Title Page: Distribution Statement, Third Party Agreement Statement, Export Control Notice Warning, Destruction Notice	Sans serif bold 10 for header and sans serif 6 - 8 for text	Upper case for header and upper and lower case for text		
Title Page: Authority Notice (Service Nomenclature)	Sans serif bold 10	Upper case		
"A" Page (Header Information): Publication Number	Sans serif bold 18	Upper case		

MIL-STD-3001-1A(AS) w/CHANGE 1

APPENDIX B

TABLE B-III. Style, capitalization, leading, and spacing.

Use	Preferred Type/Size	Capitalization	Leading	Vertical Spacing
"A" Page (Header Information): Publication Date, Revision Number, and Page Identification	Sans serif bold 10	Initial caps		
"A" Page Title	Sans serif bold 10	Upper case		48 points below TM number; 18 points above text
TPDR and HMWS (Header Information): Publication Number, Security Classification	Sans serif bold 18	Upper case		
TPDR and HMWS (Header Information): Page Identification, Publication Date	Sans serif bold 10	Upper case. Date initial caps.		
TM Number	Sans serif bold 18	Upper case		30 points from top of page
Page Number	Sans serif bold 10			30 points centered from bottom of page
Revision Number	Sans serif bold 10	Upper case for first letter of revision		
Security Classification	Sans serif bold 18	Upper case		*30 points from top of page
Work Package Marginal: Publication Date or Revision Date, and Page Numbers	Sans serif bold 10	Initial caps		
Work Package: Title for Reference Material List, Record of Applicable Technical Directives, Support Equipment Required List, and Materials Required List	Sans serif bold 10	Initial caps		
Work Package Title Block: Maintenance Level, Subject	San serif bold 10	Upper case		12 additional points after each entry

MIL-STD-3001-1A(AS) w/CHANGE 1

APPENDIX B

TABLE B-III. Style, capitalization, leading, and spacing.

Use	Preferred Type/Size	Capitalization	Leading	Vertical Spacing
Paragraph Titles	Sans serif bold 10	All upper case or upper case for first letter of each principal word (depending upon emphasis)	2	12 points below title block bottom rule; 12 points above/below text, table, or illustration; 12 points above/below warning, caution, and note headers/text
Text (including Group Assembly Parts List (GAPL))	Serif 10	Upper and lower case. GAPL text upper case.		18 points below TM number, WP or other header; 12 points above/below table or illustration; 6 points above page no.; 6 points above/below warning, caution, and note headers
Emphasis	Italic bold 10	Upper and lower case	1	
Formulas and Equations	Italic 10	Upper and lower case	1	12 points above/below text, table, or illustration
Figure Number and Title	Serif 10	Upper case for first letter of each principal word	2	18 points below illustration (within the figure area)
Legend on Illustrations	Sans serif 8	Upper case for first letter of first word	1	As required
Illustration Callouts	Sans serif 8	Upper case		As required
Illustration Captions	Sans serif bold 10	Upper case	2	18 points below illustration
Table Number and Title	Serif 10	Upper case for first letter of each principal word	2	6 points above title
Column Headers	Serif bold 10	Upper case	1	
Table Text	Serif 10	Upper and lower case	2	

MIL-STD-3001-1A(AS) w/CHANGE 1

APPENDIX B

TABLE B-III. Style, capitalization, leading, and spacing.

Use	Preferred Type/Size	Capitalization	Leading	Vertical Spacing
List Headers	Sans serif bold 10	Upper case for first letter of each principal word	2	12 points above list
*When a TM is classified, the TM number is 48 points from the top of the page and the page number 48 points from the bottom of the page. All other spacing is adjusted accordingly.				

B.5.4.3 Text development and placement.

a. Except for description and principles of operation WPs, all text shall be single (page wide) column, single spaced (double spaced between procedural steps). Text for description and principles of operation shall be double column, single spaced. Both single and double column formatted WPs can be included in a single TM if it would make the data more readable or comprehensible; however, both formats shall not be used in the same WP. Text is single spaced (double spaces between procedural steps) left justified.

b. Widows and orphans are not allowed. For example, the last line of a paragraph shall not be placed at the top of a new page (widow); the first line of a paragraph shall not be located at the bottom of the page or column, and a title or header shall not be placed on the last line of a page or column (orphan).

c. Text shall be double-spaced between paragraphs, procedural steps, and before and after the headings "WARNING," "CAUTION," and "NOTE." IPB GAPL pages shall be considered text. Layout shall conserve space without lessening usability or clarity of material. Double spacing of text within a paragraph, or similar wastefulness, is unacceptable. Blank space on a page shall be avoided whenever possible unless clarity or readability is sacrificed.

d. Procedural step text shall not be placed on illustrations.

e. Text shall not be wrapped around an illustration.

B.5.4.4 Placement of graphics. Graphics shall be placed at the end of a WP, and foldout illustrations shall be placed after the standard size graphics.

B.5.4.5 Marginal copy. The marginal copy for all pages, except the TM title page, consists of the items listed below:

a. Classified markings (if applicable). The security classification markings for manuals shall be identified in accordance with DoDM 5200.01-Volume 2, DoD 5220.22M, SECNAV M-5510.36, and [B.5.8](#).

MIL-STD-3001-1A(AS) w/CHANGE 1

APPENDIX B

b. Publication number(s) (all pages). The publication number shall be assigned by the requiring activity and shall be placed in the extreme upper left corner of the reproduction area.

(1) Standard Technical Manual Identification System (TMINS). Publication numbers derived by utilizing "TMINS" shall not be preceded by the authorizing activity's acronym (e.g., A1-XXXXX-XXX-XXX).

(2) Joint usage publications. If the publication is jointly used, the requiring activity's publication number shall be placed as required above, and the other publication number(s) shall be placed below the requiring activity's publication number.

c. Publication date. The publication date shall be one of the following: (1) Basic (initial issue) date or (2) Basic date and change date. The publication date and change number shall be assigned by the requiring activity.

(1) WP title page (first page). The publication date shall be placed below the publication number. When change pages are prepared to WPs, only the first page of the affected WP (WP title block page) shall contain the change number and date below the publication number.

(2) Second and subsequent pages. All subsequent changed pages of the affected WP shall contain the publication number and change number. The basic or change date shall not appear on the page.

d. "Blank" page numbers. "Blank" pages shall be assigned a page number, but the number and the word "blank" shall appear in parentheses on the preceding page following the preceding page number in normal bold type (e.g., "**Page 15/(16 blank)**").

B.5.4.6 Equations. The use of equations shall be held to the minimum use required by the needs of the TM user.

NOTE

The MATHPACK 911001 DTD shall be used for preparing equations. The use of some equations may be limited by the Mathpack and the output system.

a. Connecting words. Place connecting words of explanation, such as "therefore" and "similarly," flush left either on the same line with the equation or on a separate line.

b. Spacing. Use clear space above and below equations as needed. Center and indent any complex or hard-to-read expressions in a clear space between the lines of text. Start a series of such expressions at the left margin or indent in any consistent manner. Center and indent any important expression, regardless of complexity, to introduce or emphasize it.

c. Numbering and referencing to equations. When it is necessary to reference equations in the text, give the equation a reference number. The reference number consists of EQ, followed by an Arabic numeral beginning with 1 within each WP (for example, EQ 1, EQ 2, etc.).

MIL-STD-3001-1A(AS) w/CHANGE 1

APPENDIX B

B.5.4.7 Writing guidelines.

B.5.4.7.1 Abbreviations and acronyms <abbrevlist>. The use of abbreviations or acronyms not listed in COMNAVAIRFORINST 4790.2 shall be held to a minimum, and each shall be defined the first time it appears in each WP. The complete technical expression shall be fully spelled out followed by the abbreviation or acronym in parentheses.

- a. Abbreviations or acronyms shall not be used in a publication title or WP title.
- b. When a phrase is abbreviated as an acronym, capitalize the first letter of each word and do not separate letters in the acronym by periods (for example, “Illustrated Parts Breakdown (IPB)”).
- c. Abbreviations and acronyms accepted as words, such as radar, sonar, laser, etc., need not be spelled out.
- d. Abbreviations and acronyms may be plural or possessive.
- e. Spell out abbreviations and acronyms used in tables, but not found in the text or other portion of the TM, in a note to the applicable table. Spell out abbreviations and acronyms used in illustrations or figures, but not found in the text or other portion of the TM, in a note on the applicable illustration or figure.
- f. When abbreviations or acronyms are used as markings on equipment (placarding), use the same abbreviation or acronym in the TM.

B.5.4.7.2 Warnings, cautions, and notes. Procedures or practices that, if not correctly followed, could result in injury to personnel, damage or destruction of equipment, or improper system operation, shall be highlighted by warnings, cautions, and notes.

- a. Warnings and cautions shall precede the text to which they apply.
- b. Notes shall normally be placed before the applicable text; however, the note may follow the applicable text, if required for clarity.
- c. Warnings, cautions, and notes shall not contain procedural steps or direct maintenance actions, nor shall they be numbered.
- d. When a warning, caution, or note consists of two or more paragraphs, the applicable heading shall not be repeated above each paragraph. If it is necessary to use a combination of data, it shall appear in this order: warning, caution, note. Such inserts in text shall be concise and shall be used to emphasize important and critical instructions.

B.5.4.7.2.1 Format for warnings, cautions, and notes.

- a. Standard warnings and cautions consist of four parts: a heading (WARNING, CAUTION), a statement of the hazard or precaution, minimum precautions to be taken, and a possible result if the warning or caution is disregarded.

MIL-STD-3001-1A(AS) w/CHANGE 1

APPENDIX B

- b. The header **WARNING**, **CAUTION**, or **NOTE** is bold and centered above the appropriate text. Headers are not numbered. When a warning, caution, or note consists of two or more paragraphs, the header **WARNING**, **CAUTION**, or **NOTE** is not repeated above each paragraph. Warnings, cautions, and notes on unrelated topics shall not be contained under one heading.
- c. Indent all lines of warnings, cautions, or notes five spaces or characters from both left and right margins.
- d. Bulleted lists are not allowed in warnings, cautions, or notes.
- e. Warnings, cautions, or notes are not divided so that first lines appear on one page and remaining lines appear on another page. Warnings, cautions, and notes are not separated from the text to which they apply.

B.5.4.7.3 Quality assurance procedures. Procedures that are essential to equipment performance or to safety of personnel are considered to be "Quality Assurance Procedures." It is necessary to ensure that all required tasks, including final testing of the end item (verification of repair), are accomplished prior to completion of work. Control of these required actions is accomplished by the following two methods:

- a. **Highlighting in-process QA inspections.** "In-process QA inspections" are those procedures that are essential to equipment performance or to safety of personnel. These procedures shall be observed or checked by a quality assurance inspector prior to the technician proceeding to the next step in the procedure. Therefore, quality assurance required procedures shall be highlighted by the addition of the abbreviation "**(QA)**" prior to the procedure/step. An explanation of the requirements and highlighting shall be given in the introduction to the data. Examples are: required gauge readings, torque readings (excluding torque limiting), and tasks that will be subsequently covered and the quality assurance requirements cannot be verified without disassembly.
- b. **Quality assurance referencing.** Reference to following actions (the last procedural step of a procedure) shall reference the next required action.

B.5.4.7.4 Health hazard precaution data. Procedures prescribed for the operation and maintenance of equipment shall be consistent with the safety standards established by the Occupational Safety and Health Act, Public Law 91-596 and Executive Order 12196. Appropriate warnings shall be included, when hazardous chemicals, adverse health factors in the environment, or use of the equipment cannot be eliminated; refer to [B.5.4.7.4.1](#). Warnings and cautions applicable to hazardous materials shall be based on information contained in Material Safety Data Sheets (MSDS). Under the provisions of FED-STD-313, MSDS are required to be submitted for hazardous materials. In turn, MSDS shall be entered into the Hazardous Material Information System as required under the provisions of DoD 6050.05 series and OPNAVINST 5100.23. Lists of appropriate personnel protective devices shall be included.

B.5.4.7.4.1 Warnings applicable to hazardous materials. Complete warnings applicable to all hazardous materials addressed in the WPs, including appropriate personnel protective equipment

MIL-STD-3001-1A(AS) w/CHANGE 1

APPENDIX B

requirements, shall be provided in the Hazardous Materials Warnings Summary (HMWS) (refer to [B.5.3.1.4](#)). The warnings shall be developed from information provided by chemical manufacturers in Material Safety Data Sheets (MSDS) required by 29 CFR 1910.1200. MSDSs used within DoD are required to be entered into the Hazardous Materials Information Resource System (HMIRS) which is addressed in DoD 6050.05 series publications. The DoD 6050.05 series publications contain MSDSs submitted under the provisions of Federal Standard No. 313, Material Safety Data, Transportation Data and Disposal Data for Hazardous Materials Furnished to Government Activities. Additional information related to hazardous material requirements is provided in OPNAVINST 5100.23, OPNAVINST 5100.19, and OPNAVINST 5090.1.

a. Warnings applicable to hazardous materials shall be presented in WPs by the use of:

- (1) Index number (Arabic numeral identifier),
- (2) Nomenclature and specification of the hazardous material, and
- (3) Icons (nonverbal graphic symbols).

b. Starting with the number 1, the warnings shall be sequentially numbered. Each hazardous material shall be assigned only one numeric identifier. Repeated use of a specific hazardous material shall reference the numeric identifier assigned at its initial appearance. Warnings added to the WPs after the initial issue shall be assigned the next consecutive number regardless of the order of placement in the manual.

B.5.4.7.4.2 Hazardous materials referenced in text. In WP text, the caption "WARNING" shall not be used for hazardous materials.

B.5.4.7.5 Nuclear hardness. If equipment to be operated, maintained or overhauled has nuclear survivability requirements such as Overpressure and Burst, Thermal Radiation, Electro Magnetic Pulses (EMP) and Transient Radiation Effects on Electronics (TREE), applicable warnings shall be incorporated into the WP to ensure that hardness of equipment is not degraded during operation and maintenance.

B.5.4.7.5.1 Hardness critical symbols. All hardness critical processes/steps/items shall be marked with the appropriate symbols [HCP]/[HCI]/[OCP]/[OCI]/[CSP]/[CSI].

B.5.4.7.6 Electrostatic discharge (ESD) sensitive parts. If the electronic equipment to be handled, inspected, repaired, or assembled is ESD sensitive, the symbol [ESD] shall be incorporated into the applicable tasks and procedures of the technical publications to ensure that ESD sensitive parts are not degraded during handling or operation. The symbol [ESD] shall precede the procedure title. The specific step(s) in the procedure addressing handling or operation which could damage ESD sensitive parts shall be labeled by placing the symbol [ESD] between the step number and the text.

B.5.4.7.7 Ozone depleting substances (ODS). The continued use of ozone depleting substances (ODS) has been prohibited by Executive Order 12856. Describing the use of ODS materials in

MIL-STD-3001-1A(AS) w/CHANGE 1

APPENDIX B

NAVAIR manuals is prohibited. A listing of these substances may be obtained from the requiring activity.

B.5.4.7.8 Nomenclature consistency. Nomenclature of identical systems, subsystems, equipment, support equipment, components, and parts of the end item shall be consistent throughout the manual. Other terms and names shall be consistent within a manual. Statements that explain applicability for individual items of equipment shall use specific serial numbers, block designations, model designations, or similar identification. Such terms as “on later equipment” and “on early serial numbers” shall not be used. The preparing activity shall develop official/approved nomenclature lists for associate preparing activities and sub-preparing activities to ensure consistency throughout the WPs. Shortened versions of the approved nomenclature are not considered deviations. Approved nomenclature shall be used whenever the use of a common name might be ambiguous. The correct nomenclature shall be derived from one of the following sources (listed in the order of precedence):

- a. "AN" nomenclature,
- b. Nameplate nomenclature,
- c. H-6 assigned nomenclature, or
- d. Nomenclature on the drawing from which the item was manufactured.

B.5.4.7.8.1 Noun modifiers. Noun modifiers shall be added to the description of parts as required to assure positive identification, such as cotter pins/taper pins. These modifiers need not appear on the preparing activity's drawing. Noun modifiers, once added for clarity, shall be used consistently throughout the technical data.

a. Simple identifying modifiers provided for parts may be dropped after the first full identification of the item in the WP. For example, “Remove attaching bolt” is acceptable and preferred to “Remove cadmium plated steel bolt,” unless specific identification of one bolt within a group of similar objects is required.

b. When an item is identified by a common name, both this name and the correct technical name shall be clearly identified the first time the item appears in the text of a WP. The listing of common names in IPB GAPLs is not required.

B.5.4.7.8.2 Neutral terms. TMs shall make no reference to age, sex, race, or national origin. Use sex neutral terms. Terms such as “airman” and “workman” are considered sex neutral. Terms such as male and female connectors, pins, etc., are acceptable.

B.5.4.7.8.3 Military terms. Military terms used shall be in accordance with Joint Publication 1-02, or any approved dictionary or glossary of Navy military terms.

B.5.4.7.8.4 Automatic electronic test and checkout terminology. Terms used for automatic electronic test and checkout shall be in accordance with MIL-STD-1309.

MIL-STD-3001-1A(AS) w/CHANGE 1

APPENDIX B

B.5.4.7.8.5 Placard data. If all or a portion of the name of a control or display appears as a label on the equipment, that portion shall be written exactly as on the label, except that the placard shall be written in all capital letters to distinguish it from surrounding text, e.g., "POWER switch" or "MAIN PWR circuit breaker." It is also permissible to spell out the word for a symbol that cannot be reproduced by the equipment used to prepare the data.

B.5.4.7.8.6 Designation of equipment. The official designation of equipment shall be expressed in specific terms such as model number, type, serial number range, or similar terms. Nomenclature corresponding to that appearing on the equipment in the form of nameplates, decals, engraved legends or other markings shall be stated in text using the same wording that appears on the hardware.

B.5.4.7.8.7 National stock numbers. National stock numbers shall not appear in WPs.

B.5.4.7.8.8 Part numbers and reference designations. Part numbers and reference designations shall not be used in text or on illustrations except when necessary for clarity. For example:

a. Part numbers identifying specific support equipment or materials required are acceptable in text and on illustrations when more than one item has the same nomenclature; for example, "Position clamp P/N 2469-10 over retaining fixture."

b. Part numbers identifying items contained in support equipment tool kits shall be used in text or illustrations. The tool kit part number shall be included in the "Support Equipment Required" list.

c. Part numbers may be included in legends on, or adjacent to, the associated artwork as an aid in identification.

d. When necessary for clarity, the specification, standard, or part number of consumable materials (lockwire, adhesive, sealant, etc.) may be included in text and on maintenance WP illustrations but not on IPB illustrations.

e. Part numbers may be used in figure titles to further identify the assembly or component being illustrated. Part numbers shall not be used when the Reference Designation has been used.

f. Reference Designations are encouraged to be used in text to couple the item or unit under discussion with the supporting schematic or marking on the equipment.

g. Reference Designations shall be included in figure titles to further identify the item, assembly or component illustrated.

h. Use of Reference Designations on schematics is appropriate and encouraged.

B.5.4.7.9 Symbols. Graphic symbols shall be used in accordance with the standards specified in Appendix D. If possible, new or unusual symbols shall be avoided. When new or unusual symbols are required, they shall be identified at each occurrence or in a key or legend on a diagram. It is permissible to spell out symbols that cannot be reproduced on the equipment on which the data is being prepared.

MIL-STD-3001-1A(AS) w/CHANGE 1

APPENDIX B

B.5.4.7.10 Footnotes. Footnotes shall not be used. Notes shall be used when applicable.

B.5.4.7.11 References. The use of references in text can create undue hardship and/or confusion for the user of the technical data. It is recognized that use of references is required to avoid inordinate duplication of data; however, references shall be kept to a minimum. A high amount of referencing in text frequently indicates improper task analysis or LSA/LMI.

a. Reference shall not be made to coverage contained in a higher maintenance level WP or NAVAIR manual from a lower maintenance level WP or NAVAIR manual (i.e., from an OMM to an IMM).

b. Reference shall not be made to coverage contained in other than NAVAIR manuals, except when the manual has been formally assigned a NAVAIR publication number.

NOTE

Commercial or joint usage manuals shall be formally reviewed and approved for use prior to use by NAVAIR activities. When approved, the manuals are assigned NAVAIR publication numbers. Information related to review, approval and assigned number status can be provided by the requiring activity. The NAVAIR number is normally added during the next update of the manual and may not be listed on existing copies of the manual. Clarification can be provided by the requiring activity.

B.5.4.7.11.1 Mandatory compliance maintenance procedures. Mandatory compliance maintenance practices contained in NAVAIR general series manuals shall be referenced (e.g., Aviation Hydraulics, Aviation Hose and Tube Repair, Cleaning and Corrosion Control, etc.).

B.5.4.7.11.2 Maintenance procedures contained in other manuals. Maintenance procedures that are required to complete maintenance tasks that are contained in another maintenance manual shall be referenced by publication number.

B.5.4.7.11.3 Tasks performed by other work centers. Procedures that require performance of tasks by technical personnel other than those normally assigned to the subject task shall be referenced on the WP title page and in the text. For example, if the primary task is removal of a component of the flight control system that is inaccessible without removal of the power plant, a preparatory step of the procedure would be, "Remove power plant (A1-F77AA-220-300)."

B.5.4.7.11.4 Quality assurance referencing. Reference to follow-up actions. The last procedural step of a procedure shall reference the next required action, when applicable, e.g.:

a. The last step of an installation procedure shall reference testing (Operational Checkout) or a required maintenance action, e.g., "Service hydraulic system (WP 017 00)," when the maintenance procedure (installation of a hydraulic system component) required an open line.

b. The last step of a required maintenance action shall reference testing (Operational Checkout) or an additional required maintenance action, e.g., when a hydraulic actuator is replaced.

MIL-STD-3001-1A(AS) w/CHANGE 1

APPENDIX B

B.5.4.7.11.5 References to other manuals or volumes. References in the text shall be made by the referenced task title as follows:

- a. For non-WP concept publications, reference shall be made by publication number.
- b. For WP format publications, reference shall be made by publication number only.
- c. Reference shall not be made to a paragraph, figure or table number.
- d. When reference is made to a classified supplement and the discussion is incomplete without the data contained in the supplement, the classified supplement shall be listed under the "Reference Material" list at the beginning of the WP.
- e. References to a WP in another volume of the set shall be made by TM number and the applicable WP number (e.g., Remove solenoid valve (NAVAIR 02B-105AHE-62)).

B.5.4.7.11.6 References within a manual or volume. References in the text shall be made by the referenced task title as follows:

- a. WP number.
- b. Paragraphs within a WP by paragraph title and number.
- c. Figures within a WP by number.
- d. Index numbers on illustrations. Detail view identification and sheet numbers shall be added for clarity.
- e. Tables within a WP by number (if assigned).
- f. Materials such as lubricants, cleaning fluid, or fuel by Government specification number.
- g. Government specifications and standards by the basic number unless it is essential to reference a specific revision to the specification or standard. Government specifications and standards shall not be referenced for completion of maintenance tasks.
- h. Parts on diagrams by complete reference designation.
- i. Switch positions and panel markings by name as marked on the equipment.

B.5.4.7.12 Typeface and type size. Typeface, type size and spacing shall be in accordance with [B.5.4.2](#). Type shall be proportionally spaced (non mono spaced). Setting text in capital letters shall be limited to appropriate uses, such as major headings, acronyms, and equipment markings.

B.5.4.7.13 Numbering.

B.5.4.7.13.1 Numerical index of effective work packages/pages (A page). The first page shall be numbered using the word "PAGE," followed by the upper case letter "A." The second and subsequent pages shall be numbered using the word "PAGE," followed by sequentially assigned

MIL-STD-3001-1A(AS) w/CHANGE 1

APPENDIX B

upper case letters, e.g., "PAGE A, PAGE B." Numbering shall be placed in the upper right corner of the page on the same line as the requiring activity's publication date.

B.5.4.7.13.2 Technical Publications Deficiency Reports (TPDR) incorporated pages. TPDR pages shall be numbered using the acronym "TPDR," followed by sequentially assigned Arabic numerals (e.g., "TPDR-1, TPDR-2, etc."). Numbering shall be placed in the upper right corner of the page on the same line as the requiring activity's publication date.

B.5.4.7.13.3 Warnings applicable to hazardous materials page(s). The warning pages shall be numbered using the acronym "HMWS" (hazardous materials warning summary) followed by sequentially assigned Arabic numerals (e.g., "HMWS-1, HMWS-2"). Numbering shall be placed in the upper right corner of the page on the same line as the requiring activity's publication date.

B.5.4.7.13.4 Work package number. Each WP shall be assigned a permanent number. The WP number shall be considered permanent upon distribution of the basic issue of the manual and shall not change. WP numbers may be changed only when a complete revision to a manual is authorized by the requiring activity. The WP number shall be placed on each page of the WP in the extreme upper right corner of the reproduction area. WP numbers for page-based IPB manuals are not assigned as described below. For assignment of WP numbers for page-based IPB manuals, refer to MIL-STD-3001-8.

B.5.4.7.13.4.1 Work package numbering system. Each WP number shall be a five-digit number, beginning with the number 001 00. There shall be one blank space between the third and fourth numerals. The basic WP number is identified by the first three digits of the WP number. The last two digits can be used to add WPs that reflect related coverage for the same basic descriptive information or operational or maintenance task when there is a permanent configuration difference, different support equipment, or preferred and alternate procedures required. Normally all technical content WP's last two digits shall be assigned "00," indicating all required coverage for the WP subject (task). If additional WPs are required to provide permanent configuration differences, different support equipment, or preferred and alternate procedures for the same WP subject contained in the "00" WP, the additional WPs shall be assigned a "01," "02," "03," etc.

B.5.4.7.13.4.2 WP number assignment. WP numbers 001 00 and WP 002 00 are used for front and introductory information for the applicable TM. WP 003 00 through WP 999 00 shall be used in sequence for the remaining technical content WPs. The last two digits of the WP number shall be "00" indicating that it is reserved during the preparation of the basic issue of the manual to permit expansion of the manual to incorporate changed or new configuration data without affecting the WP numbers previously assigned. The numerical index WPs (numerical index of effective WPs, numerical index of part numbers, numerical index of reference designations) are normally the only exceptions to the assignment of the last two digits of the WP number in the basic issue of a manual.

B.5.4.7.13.4.3 Reserved WP numbers. WP numbers may be reserved for future use for expansion purposes, provided that the numbers reserved are not titled and are accounted for and marked "Reserved" in the numerical index of effective WPs. If a WP number has been assigned a

MIL-STD-3001-1A(AS) w/CHANGE 1

APPENDIX B

title and technical content is not available at the time of distribution, the deficiency shall be noted in the numerical index of effective WPs by the statement "To Be Provided."

B.5.4.7.13.4.4 Deleted WP numbers. WPs deleted by a pickup revision shall be accounted for and marked "Deleted" in the numerical index of effective WPs. For complete revisions, WPs shall be renumbered and assigned new WP sequence numbers in consecutive order.

B.5.4.7.13.4.5 Work package numbers - division into volumes. When a TM is divided into two or more volumes, the WP number shall maintain the sequence order. The first volume shall contain the front matter, including a comprehensive index of all volumes, and as many WPs that comply with the TM size requirements for volumes (refer to Appendix B, [B.5.4.1.3](#)) beginning with WP 001 00. The WPs contained in the second and subsequent volumes shall be numbered consecutively beginning with the number immediately following the last WP number in the preceding volume. The second and subsequent volumes shall contain an alphabetical index for the volume and the WPs contained in the volume.

B.5.4.7.13.4.6 Work package page numbers. The page number shall be centered at the bottom of the page. The pages of each WP shall be numbered consecutively in Arabic numerals beginning with the number 1.

B.5.4.7.13.4.7 Work package foldout page numbers. Foldout illustrations shall be page numbered with Arabic numbers. The first foldout page of a WP shall be assigned the next number after the last standard size text or illustration page number of the WP. The page number for a foldout page shall be so placed that the number will be visible when the page is folded. The reverse side of foldout pages shall be blank. Each foldout page number shall include a blank page notation (e.g., "27/(28 blank)").

B.5.4.7.13.4.8 Work package foldout figure numbers. All foldout figures within a WP shall be identified by an Arabic numeral. Foldouts are placed at the end of each WP; therefore, foldout figure numbers shall start with the next number after the last standard size illustration figure number of the WP. When a foldout consists of more than one sheet, the sheets shall be numbered in consecutive order following the figure title.

B.5.4.7.13.5 Paragraph numbering. Primary paragraphs within a WP shall be numbered consecutively in Arabic numerals beginning with the number 1-1, 2-1, 3-1, etc. When subordinate paragraphs are required, they shall be assigned consecutive Arabic numerals under their primary paragraph (i.e., 1-2, 1-3, 2-2, 2-3, etc.).

a. Paragraphs and subparagraphs within a WP may have titles. If titled, the title shall begin at the left margin.

(1) A first level paragraph title stands alone and is in all capital letters.

(2) A second level paragraph title is run-in and is in all capital letters.

(3) A third level paragraph title stands alone and has the first letter of the first word and of each principle word capitalized.

MIL-STD-3001-1A(AS) w/CHANGE 1

APPENDIX B

(4) A fourth level paragraph title is run-in and has the first letter of the first word and of each principle word capitalized.

(5) Paragraph text after stand-alone paragraph titles begins flush left.

(6) Procedural paragraph titles within the <proc> element shall be listed as first or second level paragraphs only.

b. If additional title levels are necessary over and above the four levels, non-bold uppercase stand-alone and non-bold uppercase run-in capital letters shall be used. No more than six (6) levels shall be used.

c. All titles are in boldface type, except as indicated in [B.5.4.7.13.5b](#) above.

B.5.4.7.13.6 Procedural step numbers. Procedural steps shall be numbered consecutively in Arabic numerals beginning with the number 1. If different levels of substeps and subordinate substeps are required to enhance clarity, these substeps shall also be numbered. Each level of substep numbering used shall be different. Procedural steps are placed immediately after paragraph or subparagraph titles, or, if applicable, after a small paragraph that introduces the procedural steps as shown by the examples below. Procedural steps, when required, shall be divided into no more than six (6) levels as follows:

1. Primary procedural step numbers (e.g., 1, 2, 3, etc.) are flush left. Text begins two spaces after the period following the numeral. The text is blocked.
 - a. The first-level procedural substep step letters (e.g., a, b, c, etc.) are immediately below the text of the first-level procedural steps. Titles are not allowed. The text is blocked.
 - (1) The second-level procedural substep step numbers (e.g., (1), (2), (3), etc.) are immediately below the text of first-level procedural substeps. Titles are not allowed. The text is blocked.
 - (a) The third-level procedural substep step letters (e.g., (a), (b), (c), etc.) are immediately below the text of second-level procedural substeps. Titles are not allowed. The text is blocked.
 1. The fourth-level procedural substep step numbers (e.g., 1, 2, 3, etc.) are immediately below the text of third-level procedural substeps. Titles are not allowed. The text is blocked.
 - a. The fifth-level procedural substep step letters (e.g., a, b, c, etc.) are immediately below the text of fourth-level procedural substeps. Titles are not allowed. The text is blocked.

If additional substep letters are required, use aa, ab, etc., after z, or (aa), (ab), etc., after (z), or aa, ab, etc., after z.

MIL-STD-3001-1A(AS) w/CHANGE 1

APPENDIX B

B.5.4.7.14 Format for tables and lists.B.5.4.7.14.1 Table locations.

a. Tables are inserted in the TM on the same page or as soon after the first reference in the text as possible.

b. Full-page tables using a horizontal (landscape) format are positioned so that the page shall be rotated 90 degrees clockwise to be read. The table number and title are placed at the top of the table.

B.5.4.7.14.2 Table numbering. Tables are numbered consecutively within each WP in the order of their reference starting with Arabic number 1. If only one table is referenced in a WP, it shall be numbered. Tables that are not referenced except from an adjacent paragraph and are one column in width shall not be numbered. Tables that are referenced in two or more paragraphs and tables that are full page width shall be numbered.

B.5.4.7.14.3 Table titles. Each table has a title. The titles identify the contents or purpose of the table and distinguish that table from others in the TM.

a. The table title consists of the word "Table" followed by the table number, a period, two spaces, and the title. Capitalize the first letter of the first and each major word of the title (e.g., Table 1. Breakdown of Engine Maintenance for Intermediate Level Activities.).

b. Center table titles above the table. If the title is too long to fit on one line, align the second line with the first letter of the title.

c. Identify tables applicable to one Service only in a joint service TM (e.g., Table 3. Fuel Indicator Correction Factors (Navy Only)).

d. Identify tables applicable to more than one service in a joint service TM (e.g., Table 1. UHF Radio Controls (Navy and Air Force Only)).

B.5.4.7.14.4 Table format. Certain required tables in MIL-STD-3001-1 through MIL-STD-3001-8 are referred to as "standard tables." Tables designated as standard have no deviations to the number of columns and the titles in the column headings. The format and table headings are automatically generated by the applicable modular DTD and FOSI or style sheet used for the functional information. The following applies to all nonstandard tables developed for a TM:

a. Place a horizontal rule at the beginning (head) and at the end (foot) of a table. Make title columns in boldface, upper case letters. Place a horizontal rule under the column titles. All tables have outside vertical rules and, if required for clarity, vertical rules between columns.

b. b. When a table is continued on more than one page, the table number and title is repeated followed by the notation "Cont" in parentheses. The closing rule is omitted at the foot of a continued table; the opening rule is continued at the head of the continued portion along with the heading title data.

MIL-STD-3001-1A(AS) w/CHANGE 1

APPENDIX B

- c. Design tables so that related entries in different columns are aligned.
- d. Align data within one column of a table by one method only, i.e., left justified, left justified with substeps indented, centered, etc. However, different columns within the same table may be presented differently, i.e., one column may have the data left justified while another column may have the data centered.
- e. Tables may contain procedural steps and substeps, with a maximum of four levels. Number the steps in accordance with [B.5.4.7.13.6](#). When space allows, indent the substeps two spaces.
- f. Illustrations may be included within a table, if necessary.

B.5.4.7.14.5 Footnotes to tables. Footnotes in tables shall not be used. Notes may be placed in tables, but not at the bottom of a page, deliberately separated from the applicable table to which they apply.

B.5.4.7.14.6 Table readability and use.

- a. There shall be a clear space between columns. Row entries in tables may also be arranged in groups separated with clear space.
- b. Entries are aligned within columns as follows:
 - (1) For decimal data, decimal points are aligned.
 - (2) For scientific notation, multiplication signs are aligned.
 - (3) All other numeric data are aligned flush right.
 - (4) Alphabetic or alphanumeric data may be aligned flush left, flush right, or centered. Data may also be indented.
- c. Units of measure are identified in appropriate row entries or as separate column headings.
- d. The user shall not be required to interpolate (estimate between table values). Avoid interpolation by expanding the table or by presenting the data in a graph.

B.5.4.7.15 Lists. Lists may be used in lieu of tables, when appropriate. Lists may be unnumbered, numbered sequentially, or lettered alphabetically. Three types of lists are identified below:

- a. Definition list. The definition list consists of the term and the definition. It may have the headers, "**Term**" and "**Definition**" above the appropriate sections of the list.
- b. Random list. The random list consists of one or more items in a random order.

MIL-STD-3001-1A(AS) w/CHANGE 1

APPENDIX B

c. Sequential list. The sequential list consists of one or more items in a specified order, such as alphabetic, numeric, or alphanumeric.

B.5.4.7.15.1 Wire list. Two types of wire lists are used to support maintenance and on-aircraft troubleshooting of aircraft wiring systems. The first type is a wire run list. The second type is a wiring reference designation list. Detailed content requirements are provided in MIL-STD-3001-5. For aircraft systems wiring TMs, the lists are not used in lieu of wiring diagrams but are used to supplement the information provided on wiring diagrams. For aeronautical equipment, airborne weapons/equipment, and support equipment TMs, these lists may be used in lieu of preparing wiring diagrams, when authorized by the requiring activity.

B.5.4.7.15.1.1 Aircraft wire run list. The aircraft wire run list shall contain the technical content information as required by MIL-STD-3001-5 and include a list of all wires for the aircraft systems, subsystems, and equipment. Wires shall be listed in alphanumeric sequence by system wire number.

B.5.4.7.15.1.2 Wiring reference designation list. The wiring reference designation list WP shall contain a list of all wiring component reference designations and pin numbers.

B.5.4.7.15.1.3 Wire run list for aeronautical equipment, airborne weapons/equipment, training systems, and support equipment. For these types of equipment manuals, wire run lists can be used in lieu of wiring diagrams when approved by the requiring activity. When approved, computer generated wire run lists may be used.

B.5.4.7.15.1.4 Placement of wire run lists. Wire lists shall be contained in WPs. Aircraft wire run list WPs shall be placed in a separate aircraft system wiring diagram manual immediately following the aircraft systems wiring diagrams. Aircraft reference designation list WPs shall immediately follow the aircraft wire run lists. When wire run list WPs are developed for other types of equipment maintenance manuals, they shall be placed where appropriate for maximum usability.

B.5.4.7.15.2 List format. Certain required lists in MIL-STD-3001-1 through MIL-STD-3001-7 are referred to as "standard lists." Lists designated as standard have no deviations to the number of columns and the titles in the column headings. The format and list headings are automatically generated by the applicable modular DTD and FOSI or style sheet used for the functional information.

B.5.4.7.16 Format for figures/illustrations.

B.5.4.7.16.1 Figure numbering. Figures are placed at the end of each WP, and with the exception of foldouts, are numbered consecutively within each WP in the order of their reference starting with Arabic number 1. If only one figure is referenced in a WP, it shall be numbered. Foldouts are placed at the end of each WP after standard size illustrations. Foldout figure numbers shall start with the next number after the last standard size illustration figure number in the WP.

MIL-STD-3001-1A(AS) w/CHANGE 1

APPENDIX B

B.5.4.7.16.2 Figure titles.

- a. Illustrations shall be assigned a figure title. The figure title shall follow the figure number. "Figure" is in upper and lower case, followed by the figure number, a period, two spaces, and the title. Capitalize the first letter of the first and each major word of the title (e.g., Figure 1. Transmitter and Antenna Waveguide Assembly). Center figure titles on the graphic image area below the graphic and begin the title on the same line with the figure number.
- b. If the title of the figure is too long to fit on one line, align the second line with the first letter of the title.
- c. Identify illustrations applicable to one Service in a joint service TM (e.g., Figure 3. Fuel Indicator (Navy Only)).
- d. Identify illustrations applicable to more than one Service in a joint service TM (e.g., Figure 3. Fuel Indicator (Navy and Air Force Only)).
- e. Each sheet of a multi-sheet illustration shall be identified by a sheet number following the figure number and title (e.g., Sheet 1, Sheet 2, etc.).
- f. Figure titles of foldout illustrations shall be visible when the illustration is folded.

B.5.4.7.16.3 Legends. Legends are part of figures and not part of the text. Nomenclature use shall be identical in both the legend and in the supporting text.

B.5.5 Graphics guidelines. The following types of graphics shall be used (as applicable) in the preparation of TMs (refer to [Appendix D](#) for graphics guidelines and examples):

- a. Line drawings.
- b. Photographs.
- c. Engineering drawings.
- d. Diagrams.
- e. Charts and graphs.

B.5.6 Changes/Revisions. When updates to NAVAIR TMs are ordered, the deliverable product shall be change pages/WPs, a pickup revision or a complete revision of the TM. The requiring activity will determine the type of update required.

B.5.6.1 Changes for TMs. When directed by the requiring activity, a change shall be prepared to the manual. A change is used to incorporate appropriate new information or clarifies, corrects, or improves existing information in the TM. Front matter, WPs, and change pages shall conform to the style and format of the basic TM and shall incorporate all approved information.

MIL-STD-3001-1A(AS) w/CHANGE 1

APPENDIX B

a. A TM change package shall consist of the following, as applicable:

- (1) Transmittal page
- (2) Front matter
- (3) Change page(s)
- (4) Work package(s)

b. Changes may consist of one or more revised, added or changed WPs and/or specific changed pages along with the related WP title block page.

c. When required, WPs may be deleted from the manual during a change cycle. Since WPs are assigned permanent numbers, deleted WP numbers shall not be reassigned to added WPs. The numerical index of effective work packages/pages (A Page) shall account for all added, changed or deleted WPs affected by the change as well as previous changes to the manual, when applicable.

d. When updates to the front matter of a TM are required, all pages shall be revised and reissued, and included in the TM change package.

e. A changed WP shall consist of a changed WP title page and those pages affected by the change to the WP, including unchanged backup pages, when applicable.

B.5.6.1.1 Change numbers. Following the basic issue or a complete revision, each change to a TM shall be numbered in sequence beginning with Change 1 and shall not exceed ten change numbers. Subsequent changes shall be numbered consecutively until a complete revision is issued.

a. When change pages are prepared to WPs, only the first page of the affected WP (WP title block page) shall contain the change number and date below the publication number. All subsequent changed pages of the affected WP shall contain the publication number and current change number. Previous change information on a page(s) not affected by the current change shall be removed.

b. The change number and date of the current affected pages shall coincide with the change number and date of the TM title page located below the date of the basic or latest revision of the publication.

B.5.6.1.2 Renumbering in a work package.

a. Paragraphs, illustrations, tables, and index numbers on illustrations added between existing ones shall be assigned the preceding number plus consecutive capital letter suffixes; e.g., 3A and 3B may be added between existing numerals 3 and 4. Suffix letters I and O shall not be used. Other than the addition of suffix letters, existing identification numbers and suffixes shall not be changed. Paragraphs, illustrations, tables and index numbers with added suffix letters shall be eliminated for a complete revision.

MIL-STD-3001-1A(AS) w/CHANGE 1

APPENDIX B

b. Deleted paragraphs, procedural steps, or callouts following index numbers on illustrations shall be indicated by placing the word “Deleted” after the affected item; e.g.: “r. Deleted.” or “2 Deleted.” If a callout is deleted from an illustration, the word “Deleted” may be placed after the appropriate number in the legend, if applicable. If a callout is deleted from an illustration without a legend, such as those used to supplement a parts list, the word “Deleted” may be placed on the illustration at the end of the leader line.

c. Added material shall be placed in proper sequential order in the WP. If this causes an overrun, the material that will not fit on the existing page shall be placed on an added page. Pages shall not be added between a right hand (odd numbered) page and a left hand (even numbered) page. If additional copy is added to the right hand page, the overrun from this page shall flow onto the back page and the overrun from the back page shall be placed on an added page. Such added pages shall always be assigned even numbers such as 2A, 2B, etc. The last added even numbered page (2A, 2B) shall be followed by the next sequential odd numbered page (for example, 2B is followed by page 3).

d. If blank space is available on either the preceding or following page of the page affected, this space may be used for overrun material, as applicable. However, correct sequential order of material must be maintained.

B.5.6.2 Change symbols. Change symbols shall be inserted to identify technical updates in text, tables and illustrations.

a. All existing change symbols shall be eliminated from the pages affected by the current change. After removal of previous change symbols, new change symbols shall be inserted highlighting material changed or added during the current change.

b. Change symbols are not required for the Alphabetical Index, IPB illustrations, and the Numerical Index of: (1) Effective Work Packages/Pages, (2) Part Numbers, or (3) Reference Designations.

B.5.6.2.1 Change symbols for text and tables.

a. Changes to text and tables (including new material located on added pages) shall be indicated by a change bar in the outer margin of double-column, formatted material and in the outer margin (opposite binding edge) of single-column, formatted material.

b. A change bar shall be placed in the outer margin opposite the table title only if the table title is changed.

c. Change symbols from a previous revision shall be deleted when a page is subsequently updated. Symbols shall show current updates only.

d. Change symbols are not required for correction of minor inaccuracies, such as spelling, punctuation, relocation of material, renumbering, etc., unless such correction changes the meaning of the information.

MIL-STD-3001-1A(AS) w/CHANGE 1

APPENDIX B

B.5.6.2.2 Change symbols for illustrations.

a. A miniature pointing hand shall be used to highlight the area containing the modified material. An acceptable alternate method for use with an extensively changed full page illustration is the use of the words 'MAJOR CHANGE' enclosed in a box. The enclosed words shall be placed in a clear space in the lower left corner of the illustration image area.

b. A change bar may be used to indicate changed text within an illustration (e.g., list, legend).

c. A change bar shall be placed to the left of the figure title only when the title text is changed.

B.5.6.3 Pickup revisions. A pickup revision incorporates the basic issue or latest revision of a manual, all previous change pages/WPs, and the new change pages/WPs that would require the issuance of an additional revision. Only those updated or added change pages/WPs shall have the current change number and date, as applicable. If a page/WP has been previously changed and is not affected by the current change, the previous symbols, change number, and date shall be retained. When change pages/WPs are ordered, the deliverable product for printing and distribution may be a pickup revision. The requiring activity will determine when a pickup revision is required.

B.5.6.4 Complete revisions. A complete revision requires rewrite and reorganization of the technical content. All pages, paragraphs, illustrations and tables shall be renumbered to establish the correct sequence. All existing changes to the basic manual shall be merged. If applicable, WPs shall be renumbered and assigned new WP sequence numbers in consecutive order (see [B.5.4.7.13.4](#)). All existing change numbers, change bars, dates and change symbols shall be removed. Change symbols shall be inserted only on those pages incorporating new or changed data during the preparation of the complete revision. The revision date will be assigned by the requiring activity. A complete revision should be considered when a combination of new material and previous changes exceed 60 percent of the total pages in the manual. The requiring activity will decide when a complete revision is desired.

B.5.6.5 Supersedure notice. A supersedure notice is always required when a revision is issued and may be required when a TM issue supersedes other TMs or portions of TMs.

B.5.6.5.1 Title page supersedure notice. The supersedure notice is placed on the title page of the manual and shall be tailored to the application (refer to [B.5.3.1.1](#)).

B.5.6.5.2 WP title block supersedure notice. When a WP is completely revised, the supersedure notice is placed in the title block below the effectivity notice (refer to [B.5.3.2.1.1](#)).

B.5.7 Comprehensibility. TMs shall be written for the target audience. Reading grade level shall be as specified by the requiring activity.

MIL-STD-3001-1A(AS) w/CHANGE 1

APPENDIX B

B.5.8 Security classification markings

B.5.8.1 General. When preparation of a classified TM is specified by the requiring activity, the security classification markings shall be identified in accordance with DoDM 5200.01-Volume 2, DoD 5220.22M, SECNAV M-5510.36 and Executive Order 13526. Specific markings for classified manuals, pages, WPs, paragraphs, tables and illustrations are as prescribed herein. For guidance on security classification and handling restrictive markings on Compact Disk-Read Only Memory (CD-ROM), refer to DoDM 5200.01-Volume 2.

B.5.8.2 Overall classification. The overall classification assigned to all TMs shall agree with the highest classification assigned to any page therein. Place the overall classification assigned to a TM at the top and bottom of the title page. When this results in a title page being marked with a higher classification than that assigned to the contents of that page, provide an explanation of the higher classification on that page under the bottom classification marking. For example:

CONFIDENTIAL or SECRET
(This page is UNCLASSIFIED) (This page is CONFIDENTIAL)

B.5.8.3 Classification of alphabetical index. Every effort shall be made to use unclassified captions/titles in the alphabetical index. When classified captions/titles are used, place the security classification of the caption/title between the paragraph number and the caption/title. The classification marking is for the caption/title only and does not indicate classification of the content of WPs, tables, or illustrations. Do not mark unclassified titles.

B.5.8.4 Classification of work packages. Each WP is considered a stand-alone unit and for classification purposes is equivalent to a portion of the publication. Mark each page of the WP with the highest classification required for any element of the WP. When any page is marked with a higher classification than that assigned to its contents, provide an explanation on that page beneath the bottom classification marking. For example:

CONFIDENTIAL or SECRET
(This page is UNCLASSIFIED) (This page is CONFIDENTIAL)

B.5.8.5 Classification of pages. Mark each page (other than title page and WP pages) according to its highest content. When classifications of two pages of one sheet (two pages back to back) differ, use the higher classification on both pages. When two pages of one sheet are unclassified, mark each page unclassified. When any page is marked with a higher classification than that assigned to its contents, explain the higher classification on that page beneath the bottom classification marking. For example:

CONFIDENTIAL or SECRET
(This page is UNCLASSIFIED) (This page is CONFIDENTIAL)

If a blank page backs up a classified page, show the classification of the classified page on the blank page and explain the higher classification as described above. Blank pages backing up unclassified pages need not be marked. If the classification shown on the last page of a publication is not the same as that shown on the title page, then add a blank sheet to the back of

MIL-STD-3001-1A(AS) w/CHANGE 1

APPENDIX B

the publication showing the same classification as the title page. The last page, if blank, of the publication reflects the same classification as the title page (i.e., the highest classification of the publication).

B.5.8.6 Paragraph and table markings. Mark all paragraphs, subparagraphs, steps and tables to show the level of classification contained in or revealed by it, or that it is unclassified. Classification levels are shown by the appropriate classification symbols between the paragraph number, procedural step number or letter and the start of the text and between a table number and title. Use the following parenthetical symbols: (TS) for Top Secret, (S) for Secret, (C) for Confidential, and (U) for Unclassified. In marking warnings, cautions, or notes, place the appropriate marking immediately preceding and to the left of the warnings, cautions, or notes involved. The abbreviated classification markings are for internal content use only, not for overall marking of pages. These instructions apply to all new and revised publications.

B.5.8.7 Illustration markings. Mark illustrations, photographs, figures, graphs, drawings, charts and similar portions of classified documents to show their classification or unclassified status. Ensure that markings stand out and are placed within the illustration in the lower right corner. Mark captions, if used, on the basis of their content alone by placing the symbol "(TS)," "(S)," "(C)," or "(U)" immediately before the caption.

B.5.8.8 Downgrading/Declassification. The downgrading/declassification notice **<downgradenot>** on the title page and downgrading/declassification actions shall be in accordance with DoDM 5200.01-Volume 1, DoD 5220.22M and SECNAV M-5510.36.

MIL-STD-3001-1A(AS) w/CHANGE 1

APPENDIX B

A1-445AC-450-010

1 May 1995

TECHNICAL MANUAL

**ORGANIZATIONAL MAINTENANCE
PRINCIPLES OF OPERATION**

LANDING GEAR AND RELATED SYSTEMS

MODEL NUMBER F/A-18A/B/C/D

161353 AND SUBSEQUENT

This manual prepared by NAVSURFWARCENDIV, Crane, IN, Code 8024.

This manual supersedes A1-F18AC-130-100, dated 1 JUNE 1989, changed 1 October 1994.

DISTRIBUTION STATEMENT C. Distribution authorized to U.S. Government agencies only and their contractors to protect publications required for official use or for administrative or operational purposes only, determined on 1 May 1995. Other requests for this document shall be referred to Commanding Officer, Naval Air Technical Data and Engineering Service Command, Naval Air Station North Island, P.O. Box 357031, Building 90 Distribution, San Diego, CA 92135-7031.

DESTRUCTION NOTICE - For unclassified, limited documents, destroy by any method that will prevent disclosure of contents or reconstruction of the document.

Published by Direction of the Commander, Naval Air Systems Command

NSN 0801LP3105060

FIGURE B-1. Example of a title page.

MIL-STD-3001-1A(AS) w/CHANGE 1

APPENDIX B

A1-AV8BB-MRC-300	
CARD DECK PHASED MAINTENANCE REQUIREMENTS CARDS NAVY MODEL	
AV-8B 61573 and Subsequent TAV-8B 162747 and Subsequent	
THIS CHANGE INCLUDES IRAC 93 AND IRAC 94.	
<u>DISTRIBUTION STATEMENT C.</u> Distribution authorized to U.S. Government Agencies only and their contractors to protect publications required for official use or for administrative or operational purposes only, determined on 1 July 1994. Other requests for this document shall be referred to Commanding Officer, Naval Air Technical Data and Engineering Service Command, Naval Air Station North Island, P.O. Box 357031, Building 90 Distribution, San Diego, CA 92135-7031.	
<u>DESTRUCTION NOTICE</u> - For unclassified, limited documents, destroy by any method that will prevent disclosure of contents or reconstruction of the document.	
PUBLISHED BY DIRECTION OF THE COMMANDER, NAVAL AIR SYSTEMS COMMAND	
0801LP1036618	15 SEPTEMBER 2001 Change 15 - 1 October 2004

FIGURE B-2. Example of an aircraft, QECA or ALSS card deck title card.

NAVAIR 17-600-117-6-2	
CARD DECK PERIODIC MAINTENANCE REQUIREMENTS CARDS HELICOPTER ENGINE AND AFT TRANSMISSION WINCH	
A02E5808-43 AMERICAN CHAIN AND CABLE COMPANY, INC. GMAC	
THIS CHANGE INCORPORATES IRAC 93 AND IRAC 94.	
<u>DISTRIBUTION STATEMENT C.</u> Distribution authorized to U.S. Government agencies and their contractors to protect publications required for official use or for administrative or operational purposes only, determined on 15 April 1999. Other requests for this document shall be referred to Commanding Officer, Naval Air Technical Data and Engineering Service Command, Naval Air Station North Island, P.O. Box 357031, Building 90 Distribution, San Diego, CA 92135-7031.	
<u>DESTRUCTION NOTICE</u> - For unclassified, limited documents, destroy by any method that will prevent disclosure of contents or reconstruction of the document.	
PUBLISHED BY DIRECTION OF THE COMMANDER, NAVAL AIR SYSTEMS COMMAND	
	1 OCTOBER 2002 Change 20 - 1 May 2005

FIGURE B-3. Example of an armament/special stores, support equipment or target (surface or aerial) card deck title card.

MIL-STD-3001-1A(AS) w/CHANGE 1

APPENDIX B

AG-500QA-MRC-000

**CARD DECK
PERIODIC MAINTENANCE REQUIREMENTS CARDS
SH-60B PECULIAR SUPPORT EQUIPMENT**

THIS CHANGE INCLUDES IRAC 93 AND IRAC 94.

DISTRIBUTION STATEMENT C. Distribution authorized to U.S. Government Agencies only and their contractors to protect publications required for official use or for administrative or operational purposes only, determined on 1 July 1994. Other requests for this document shall be referred to Commanding Officer, Naval Air Technical Data and Engineering Service Command, Naval Air Station North Island, P.O. Box 357031, Building 90 Distribution, San Diego, CA 92135-7031.

DESTRUCTION NOTICE - For unclassified, limited documents, destroy by any method that will prevent disclosure of contents or reconstruction of the document.

PUBLISHED BY DIRECTION OF THE COMMANDER, NAVAL AIR SYSTEMS COMMAND

1 OCTOBER 2002
Change 20 - 1 May 2005

FIGURE B-4. Example of a PSE card deck title card.

NAVAIR 01-XXX-6-4
PHASED MAINTENANCE REQUIREMENT CARDS PHASE A
OR
NAVAIR 02B-XXX-6-3
QUICK ENGINE CHANGE MAINTENANCE REQUIREMENT CARDS MODEL A-4E AIRCRAFT

FIGURE B-5. Example of phase/QEC/ALSS cover cards.

MIL-STD-3001-1A(AS) w/CHANGE 1

APPENDIX B



FIGURE B-6. Example of a PSE cover card.

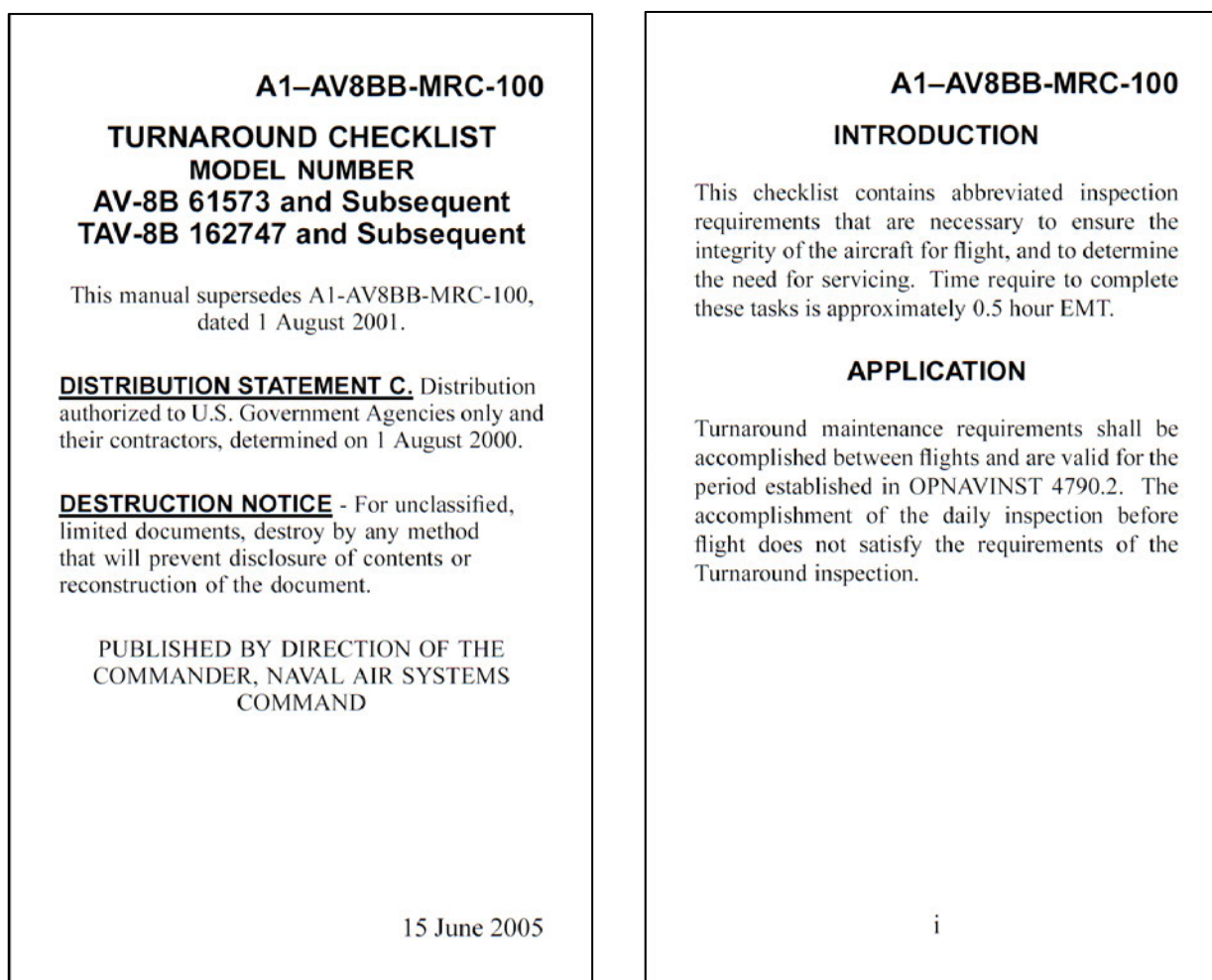

FIGURE B-7. Example of a title/introduction/application page for checklists.

MIL-STD-3001-1A(AS) w/CHANGE 1

APPENDIX B

NAVAIR A1-SRRPV-MMI-250**PAGE A**

Change 4 - 4 September 2008

NUMERICAL INDEX OF EFFECTIVE WORK PACKAGES/PAGES

List of Current Changes

Original 0	1 March 1996	2	1 June 1999	4	4 September 2008
1	1 March 1996	3	1 March 2004		

Only those work packages/pages assigned to the manual are listed in this index. If changed work packages or pages are issued, insert the changed work package/pages and dispose of the superseded work package/pages, including classified data, in accordance with applicable regulations. The portion of the text affected by the change is indicated by change bars in the outer text margin. Changes to illustrations are indicated by pointing hands or the use of the words "MAJOR CHANGE" enclosed in a box, as applicable. A change bar adjacent to an illustration figure title indicates that only the title of the illustration has changed.

Total number of pages assigned to this manual is 46 consisting of the following:

WP/Page No.	Change No.	WP/Page No.	Change No.	WP/Page No.	Change No.
Title	4	004 00/2-A	1	011 00/1	0
A	0	004 00/2-B Blank	0	011 00/2 Blank	0
TPDR-1	1	004 00/3	2	012 00/1	2
TPDR-2 Blank	1	004 00/4 Blank	0	012 00/2 Blank	0
HMWS-1	0	005 00/1	0	013 00/1	0
HMWS-2	0	005 00/2 Blank	0	013 00/2 Blank	0
HMWS-3	0	006 00/1	0	014 00/1	0
HMWS-4	0	006 00/2 Blank	0	014 00/2 Blank	0
001 00/1	1	007 00/1	0	015 00/1	0
001 00/2	0	007 00/2 Blank	0	015 00/2 Blank	0
002 00/1	4	008 00/1	0	016 00/1	0
002 00/2 Blank	0	008 00/2 Blank	0	016 00/2 Blank	0
003 00/1	0	009 00/1	1	017 00/1	0
003 00/2 Blank	0	009 00/2 Blank	0	017 00/2 Blank	0
004 00/1	2	010 00/1	0		
004 00/2	2	010 00/2 Blank	0		

FIGURE B-8. Example of a numerical index of effective work packages/pages.

MIL-STD-3001-1A(AS) w/CHANGE 1

APPENDIX B

						NAVAIR 17-600-117-6-2	
LIST OF EFFECTIVE CARDS							
Insert latest changed cards; dispose of superseded cards in accordance with applicable regulations.							
NOTE: On a changed card, the portion of the text affected by the latest change is indicated by a vertical line, or other change symbol, in the outer margin of the card,							
Dates for issue for original and changed cards are:							
0.....1 Oc 02	(IRAC 86 and IRAC 87 inc.)	9.....1 Jun 03	16.....15 Mar 04				
(Including previously incorporated IRAC 1 through 80.)	4.....15 Jan 03	(IRAC 90 inc.)	17.....15 Jul 04				
(IRAC 81 cancelled.) (IRAC 82 through 85 inc.)	(IRAC 88 inc.)	10.....15 Jun 03	18.....1 Oct 04				
1.....1 Nov 02	5.....1 Feb 03	IRAC 91 inc.)	19.....15 Oct 04				
2.....1 Dec 02	(IRAC 89 inc.)	11.....1 Jul 03	(IRAC 92 inc.)				
3.....15 Dec 02	6.....15 Mar 03	12.....15 Aug 03	20.....1 May 05				
	7.....1 Apr 03	13.....15 Sep 03	(IRAC 93 and IRAC 94 inc.)				
	8.....15 April 03	14.....15 Oct 03					
Total number of cards in this set is 554 consisting of the following:							
CARD NO.	CHANGE NO.	CARD NO.	CHANGE NO.	CARD NO.	CHANGE NO.	CARD NO.	CHANGE NO.
Title.....	20	TPDR-2 Blank.....	20	1.1.....	20	1.5.....	20
A.....	20	HMWS-1.....	20	1.2.....	20	1.6.....	20
B.....	20	i.....	20	1.3.....	20	1.7.....	20
C Blank.....	20	ii.....	20	1.4.....	20	2.0.....	18
TPDR-1.....	20	1.0.....	20	1.4.....	20	2.1.....	18
A Change 20							

FIGURE B-9. Example of an "A" card.

MIL-STD-3001-1A(AS) w/CHANGE 1

APPENDIX B

AW394AC-750-000 1 February 1997	TPDR-1/(TPDR-2 blank)
INTERMEDIATE AND DEPOT MAINTENANCE WITH ILLUSTRATED PARTS BREAKDOWN	
LIST OF TECHNICAL PUBLICATION DEFICIENCY REPORTS INCORPORATED	
AIRCRAFT GUIDED MISSILE LAUNCHER LAU MODEL NUMBER 115/A PART NUMBERS 74A73051-1003, 74A73051-1007	
MODEL NUMBER 115A/A PART NUMBERS 74A73051-1009, 74A73051-1011	
MODEL NUMBER 115C/A PART NUMBERS 74A73051-1013, 74A73051-1015	
1. The TPDRs listed below have been incorporated in this issue.	
IDENTIFICATION NUMBER/ QA SEQUENCE NUMBER	LOCATION
NAVAL AIR STATION LEMOORE/N44321-92-0146	WP 008 00
NAWC WEAPONS DETACHMENT NAS MIRAMAR/R09111-96-025	WP 011 02
NAWC WEAPONS DETACHMENT NAS MIRAMAR/R09111-96-026	WP 011 02
NAWC WEAPONS DETACHMENT NAS MIRAMAR/R09111-96-027	WP 011 02
NAWC WEAPONS DETACHMENT NAS MIRAMAR/R09111-96-028	WP 011 02
USS THEODORE ROOSEVELT (CVN 71)/V21247-0049	WP 012 00

FIGURE B-10. Example of a technical publication deficiency report (TPDR).

MIL-STD-3001-1A(AS) w/CHANGE 1

APPENDIX B

CARD TPDR-1	NAVAIR 17-600-117-6-2 DATE 1 MAY 2005	CHANGE NO.	TECHNICAL PUBLICATION DEFICIENCY REPORTS
-----------------------	--	-----------------------------	--

LIST OF TECHNICAL PUBLICATION DEFICIENCY REPORTS INCORPORATED

<u>Identification No./QA Sequence No.</u>	<u>Location</u>
01211-2007-0001	Cards 2 thru 4
01223-2007-0006	Card 2
09412-2004-0013	Card 2
09412-2004-0014	Card 3
09412-2004-0015	Card 2

End of Card

(Card TPDR-2 Blank)

FIGURE B-11. Example of technical publications deficiency report (TPDR) card.

MIL-STD-3001-1A(AS) w/CHANGE 1

APPENDIX B





NAVAIR A1-F18AC-130-100 1 May 1995	HMWS-1
INTERMEDIATE MAINTENANCE WITH ILLUSTRATED PARTS BREAKDOWN	
WARNINGS APPLICABLE TO HAZARDOUS MATERIALS	
ELECTRICAL EQUIPMENT RACK MT-6809/APG-73 PART NUMBER 3525078-110 This WP supersedes HMWS WP, dated 15 March 1994.	
1-1. INTRODUCTION.	
<p>1-2. Warnings for hazardous materials listed in this manual are designed to warn personnel of hazards associated with such items when they come in contact with them by actual use. Additional information related to hazardous materials is provided in DOD 6050.05, DOD Hazard Communication Program, OPNAVINST 5100.23, Navy Occupation Safety and Health (NAVOSH) Program Manual, OPNAVINST 5100.19, NAVOSH for Forces Afloat, OPNAVINST 5090.1, Environmental Readiness Manual, and OPNAVINST 4110.2, Hazardous Material Control and Management (HMC&M). For each hazardous material used within the Navy, a Material Safety Data Sheet (MSDS) must be available for review by users in Hazardous Materials Information Resource System (HMIRS). Consult your local safety and health staff concerning any questions on hazardous chemicals, MSDS, personal protective equipment requirements, and appropriate handling and emergency procedures and disposal guidance.</p> <p>1-3. Complete warnings for hazardous materials referenced in this manual are identified by use of an icon, nomenclature, specification or part number of the material, and a numeric identifier. The numeric identifiers have been assigned to the hazardous materials in the order of their appearance in the manual. Each hazardous material is assigned only one numeric identifier. Repeated use of a specific hazardous material references the numeric identifier assigned at its initial appearance. Warnings added to the manual after the initial issue will be assigned the next consecutive number regardless of its placement in the manual. The approved icons and their application are shown on HMWS-2 through HMWS-4.</p> <p>1-4. In the text of the manual, the WARNING caption will not be used for hazardous materials. Such warnings will be identified by an icon and numeric identifier. The material nomenclature will also be provided. The user is directed to refer to the corresponding numeric identifier listed below for the complete warning applicable to the hazardous material.</p>	
EXPLANATION OF HAZARDOUS MATERIALS ICONS	
	
<p>Biological The abstract symbol shows that a material may contain bacteria or viruses that present danger to life or health.</p>	<p>Cryogenic The symbol of a hand in a block of ice shows that the material is extremely cold and can injure human skin or tissue.</p>
	
<p>Chemical Chemical The symbol of drops of a liquid onto a hand shows that the material will cause burns or irritation of human skin or tissue.</p>	<p>Explosion The rapidly expanding symbol shows that the material may explode if subjected to high temperatures, sources of ignition, or high pressure.</p>

FIGURE B-12. Example of hazardous materials warnings summary.

MIL-STD-3001-1A(AS) w/CHANGE 1

APPENDIX B

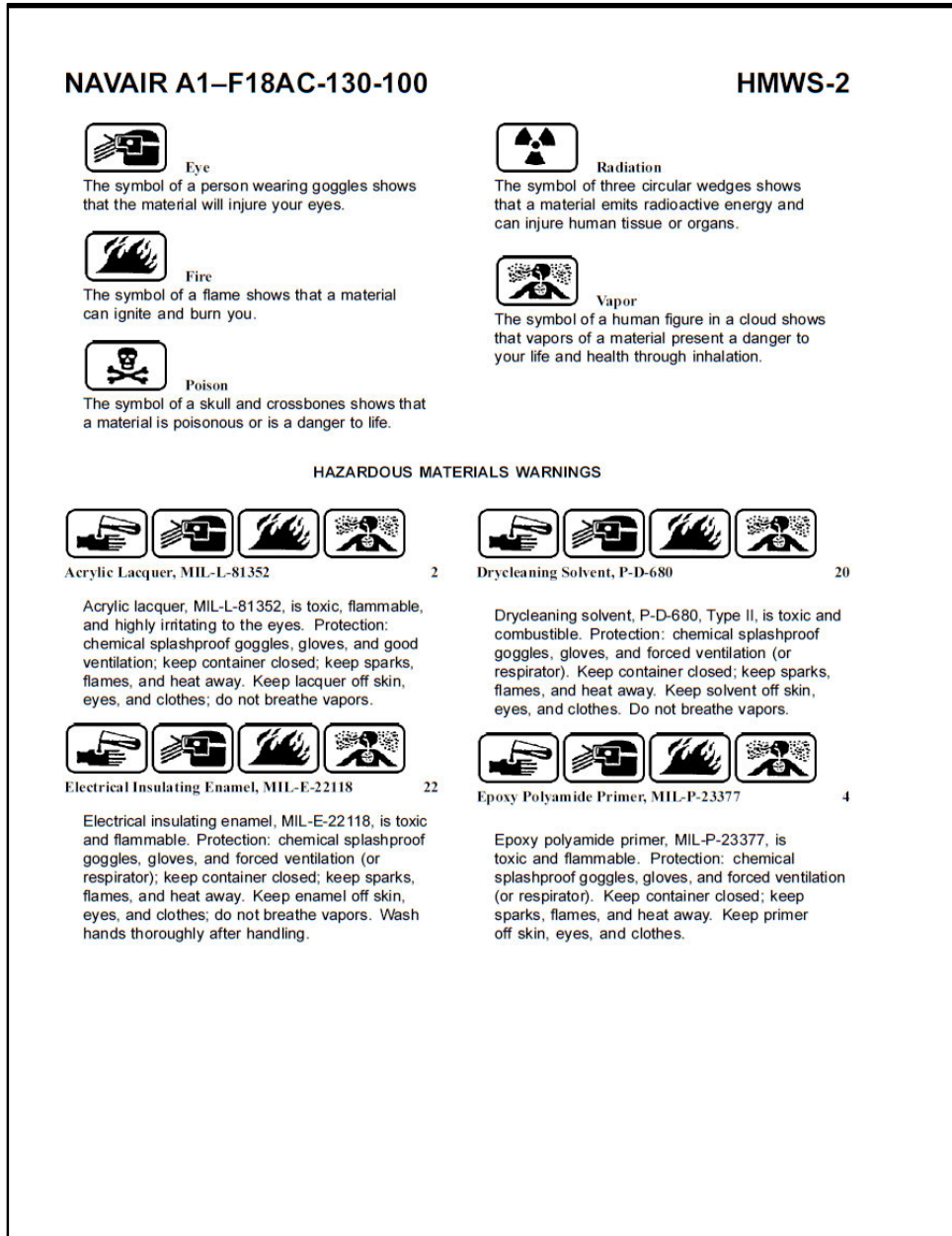

FIGURE B-12. Example of hazardous materials warnings summary. - Continued.

MIL-STD-3001-1A(AS) w/CHANGE 1

APPENDIX B









	<p>Biological</p> <p>The abstract symbol shows that a material may contain bacteria or viruses that present danger to life or health.</p>
	<p>Chemical</p> <p>The symbol of a liquid dripping onto a hand shows that the material will cause burns or irritation to human skin or tissue.</p>
	<p>Cryogenic</p> <p>The symbol of a hand in a block of ice shows that the material is extremely cold and can injure human skin or tissue.</p>
	<p>Explosion</p> <p>This rapidly expanding symbol shows that the material may explode if subjected to high temperature, sources of ignition, or high pressure.</p>
	<p>Eye Protection</p> <p>The symbol of a person wearing goggles shows that the material will injure the eyes.</p>
	<p>Fire</p> <p>The symbol of a fire shows that the material may ignite and cause burns.</p>
	<p>Poison</p> <p>The symbol of a skull and crossbones shows that the material is poisonous or is a danger to life.</p>
	<p>Radiation</p> <p>The symbol of three circular wedges shows that a material emits radioactive energy and can injure human tissue or organs.</p>
	<p>Vapor</p> <p>The symbol of a human figure in a cloud shows that material vapors present a danger to life or health.</p>

FIGURE B-13. Example of icons applicable to hazardous materials warnings.

MIL-STD-3001-1A(AS) w/CHANGE 1

APPENDIX B

CARD HMWS-1	A1-C3AAA-MRC-300 DATE 1 JANUARY 1982	CHANGE NO.	WARNINGS APPLICABLE TO HAZARDOUS MATERIALS
-----------------------	---	----------------------	--

INTRODUCTION

Warnings for hazardous materials listed in this manual are designed to warn personnel of hazards associated with such items when they come in contact with them by actual use. Additional information related to hazardous materials is provided in DoD 6050.05, OPNAVINST 5100.23, OPNAVINST 5100.19, OPNAVINST 5090.1, and OPNAVINST 4110.2. For each hazardous material used within the Navy, a Material Safety Data Sheet (MSDS) must be available for review by users in Hazardous Materials Information Resource System (HMIRS). Consult your local safety and health staff concerning any questions on hazardous chemicals, MSDS, personal protective equipment requirements, and appropriate handling and emergency procedures and disposal guidance.

Complete warnings for hazardous materials referenced in this card deck are identified by use of an icon, nomenclature, specification or part number of the material, and a numeric identifier. The numeric identifiers have been assigned to the hazardous materials in the order of their appearance in the card deck. Each hazardous material is assigned only one numeric identifier. Repeated use of a specific hazardous material references the numeric identifier assigned at its initial appearance. Warnings added to the card deck after the initial issue will be assigned the next consecutive number regardless of its placement in the card deck.

In the text of the card deck, the WARNING caption will not be used for hazardous materials. Such warnings will be identified by an icon and numeric identifier. The material nomenclature will also be provided. The user is directed to refer to the corresponding numeric identifier listed below for the complete warning applicable to the hazardous material

Continued

FIGURE B-14. Example of warnings applicable to hazardous materials card.

CARD HMWS-2	A1-C3AAA-MRC-300 DATE 1 JANUARY 1982	CHANGE NO.	WARNINGS APPLICABLE TO HAZARDOUS MATERIALS
-----------------------	---	----------------------	--

EXPLANATION OF HAZARD SYMBOLS

 **Biological**
The abstract symbol bug shows that a material may contain bacteria or viruses that present a danger to your life or health.

 **Chemical**
The symbol of drops of a liquid onto a hand shows that a material will cause burns or irritation of human skin or tissue.

 **Cryogenic**
The symbol of a human hand in a block of ice shows that the material is extremely cold and can injure human skin or tissue.

Continued

FIGURE B-14. Example of warnings applicable to hazardous materials card. - Continued.

MIL-STD-3001-1A(AS) w/CHANGE 1

APPENDIX B

CARD HMWS-3	A1-C3AAA-MRC-300 DATE 1 JANUARY 1982	CHANGE NO.	WARNINGS APPLICABLE TO HAZARDOUS MATERIALS
-----------------------	---	----------------------	--

 **Explosion**
The rapidly expanding symbol shows that the material may explode if subjected to high temperatures, sources of ignition, or high pressure.

 **Eye**
The symbol of a person wearing goggles shows that the material will injure your eyes.

 **Fire**
The symbol of a flame shows that a material can ignite and burn you.

Continued

FIGURE B-14. Example of warnings applicable to hazardous materials card. - Continued.

CARD HMWS-4	A1-C3AAA-MRC-300 DATE 1 JANUARY 1982	CHANGE NO.	WARNINGS APPLICABLE TO HAZARDOUS MATERIALS
-----------------------	---	----------------------	--

 **Poison**
The symbol of a skull and crossbones shows that a material is poisonous or is a danger to life.

 **Radiation**
The symbol of three circular wedges shows that a material emits radioactive energy and can injure human tissue or organs.

 **Vapor**
The symbol of a human figure in a cloud shows that vapors of a material present a danger to your life and health through inhalation.

Continued

FIGURE B-14. Example of warnings applicable to hazardous materials card.- Continued.

MIL-STD-3001-1A(AS) w/CHANGE 1

APPENDIX B

CARD HMWS-5	A1-C3AAA-MRC-300 DATE 1 JANUARY 1982	CHANGE NO.	WARNINGS APPLICABLE TO HAZARDOUS MATERIALS
HAZARDOUS MATERIALS WARNINGS			
Index	Material	Warning	
1	SOLVENT, DRY CLEANING, P-D-680 Type II 	<p>Dry cleaning solvent is combustible. Do not use near open flames, welding areas, or on hot surfaces. Prolonged contact on skin with liquid can cause dermatitis. Repeated inhalation of vapor can irritate nose and throat and can cause dizziness. If any liquid contacts skin or eyes, immediately flush affected areas with water. Remove solvent saturated clothing. If vapor causes dizziness, go to fresh air. When handling liquid or applying it in an air exhausted, partially covered tank, wear approved gloves. When handling liquid or applying in an unexhausted, uncovered tank or workbench, wear approved respirator and gloves.</p> <p style="text-align: right;">End of Card (Card HMWS-6 Blank)</p>	

FIGURE B-14. Example of warnings applicable to hazardous materials card. - Continued.

MIL-STD-3001-1A(AS) w/CHANGE 1

APPENDIX B

A1-F18AC-742-300		001 00
1 April 1995		
ORGANIZATIONAL MAINTENANCE		
SYSTEM MAINTENANCE WITH IPB		
ALPHABETICAL INDEX		
RADAR SYSTEM		
<u>Title</u>	<u>WP/Page</u> <u>Number</u>	
ANTENNA		
ILLUSTRATED PARTS BREAKDOWN; AS-3254/APG-65; 60E-A501	008 00	
INTRODUCTION.....	008 00/1	
ANTENNA HOLDING FIXTURE ILLUSTRATED PARTS BREAKDOWN.....	009 00	
INSTALLATION	010 00	
REMOVAL.....	011 00	
REPAIR.....	012 00	
GIMBAL BUMPER.....	012 00/1	
INSTALLATION.....	012 00/1	
REMOVAL.....	012 00/4	
UPPER/LOWER SHELL ASSEMBLY; 163985 AND UP	012 00/4	
INSTALLATION.....	012 00/4	
REMOVAL.....	012 00/4	
FLOOD REPAIR; 60E-A512	013 00	
ILLUSTRATED PARTS BREAKDOWN.....	013 00/2	
INSTALLATION.....	013 00/2	
REMOVAL.....	013 00/1	
ARRAY, PLANAR		
CABLE ASSEMBLY; 60W-A539	021 00	
ILLUSTRATED PARTS BREAKDOWN.....	021 00/4	
INSTALLATION.....	021 00/2	
REMOVAL.....	021 00/2	
CABLE ASSEMBLY; 60W-A523	025 00	
ILLUSTRATED PARTS BREAKDOWN.....	025 00/3	
INSTALLATION.....	025 00/2	
REMOVAL.....	025 00/2	
CABLE ASSEMBLY; 60W-A538	026 00	
ILLUSTRATED PARTS BREAKDOWN.....	026 00/3	
INSTALLATION.....	026 00/2	
REMOVAL.....	026 00/2	
FLEXIBLE WAVEGUIDES	022 00	
INSTALLATION.....	022 00/3	
REMOVAL.....	022 00/2	
REPAIR.....	024 00	
SCREW REPLACEMENT.....	024 00/1	
TORQUE REQUIREMENTS.....	024 00/2	
1/(2 blank)		

FIGURE B-15. Example of an alphabetical index work package.

MIL-STD-3001-1A(AS) w/CHANGE 1

APPENDIX B

NAVAIR 01-H1AAC-2-3.1		001 00
1 October 1990		
ORGANIZATIONAL MAINTENANCE		
ALPHABETICAL INDEX		
TESTING AND TROUBLESHOOTING POWER PLANT AND RELATED SYSTEMS		
<u>Title</u>	<u>01-H1AAC-2</u>	<u>WP/Page Number</u>
POWER PLANT AND RELATED SYSTEMS		
ENGINE ASSEMBLY	-3.1	004 00
GENERAL MAINTENANCE PROCEDURES AND PRECAUTIONS		004 00/01
LIST OF EQUIPMENT		004 00/01
TESTING/TROUBLESHOOTING		004 00/05
TROUBLESHOOTING CHECKS		004 00/03
POWER LEVER CONTROLS	-3.1	005 00
GENERAL MAINTENANCE PROCEDURES AND PRECAUTIONS		005 00/01
LIST OF EQUIPMENT		005 00/01
TESTING/TROUBLESHOOTING		005 00/04
DROOP COMPENSATOR CONTROLS	-3.1	006 00
GENERAL MAINTENANCE PROCEDURES AND PRECAUTIONS		006 00/01
LIST OF EQUIPMENT		006 00/01
TESTING/TROUBLESHOOTING		006 00/04
FUEL SUPPLY SYSTEM	-3.2	004 00
GENERAL MAINTENANCE PROCEDURES AND PRECAUTIONS		004 00/01
LIST OF EQUIPMENT		004 00/01
TESTING/TROUBLESHOOTING		004 00/04
COMBINING GEARBOX	-3.2	005 00
GENERAL MAINTENANCE PROCEDURES AND PRECAUTIONS		005 00/01
LIST OF EQUIPMENT		005 00/01
TESTING/TROUBLESHOOTING		005 00/04
TESTING AND TROUBLESHOOTING POWER PLANT AND RELATED SYSTEMS		
ALPHABETICAL INDEX	-3.1	001 00

1/(2 blank)

FIGURE B-16. Example of an alphabetical index work package for a multi-volume TM.

MIL-STD-3001-1A(AS) w/CHANGE 1

APPENDIX B

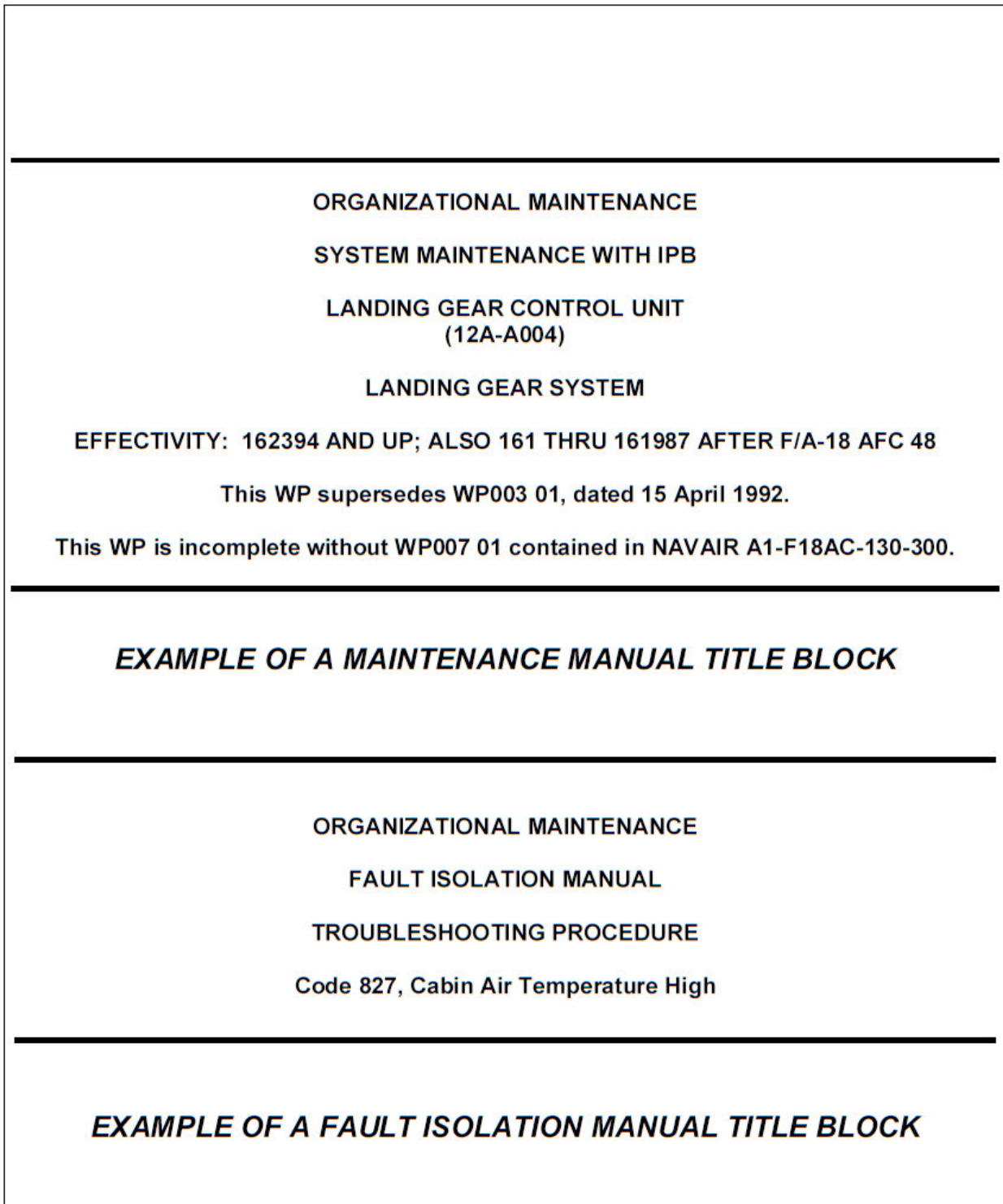

FIGURE B-17. Examples of a work package title block.

MIL-STD-3001-1A(AS) w/CHANGE 1

APPENDIX B

AW-394AC-750-000		001 01	
1 February 1997			
INTERMEDIATE AND DEPOT MAINTENANCE WITH ILLUSTRATED PARTS BREAKDOWN			
NUMERICAL INDEX OF PART NUMBERS			
AIRCRAFT GUIDED MISSILE LAUNCHER LAU-115/A PART NUMBERS 74A730351-1003 AND 74A730351-1007			
AIRCRAFT GUIDED MISSILE LAUNCHER LAU-115A/A PART NUMBERS 74A730351-1009 AND 74A730351-1011			
AIRCRAFT GUIDED MISSILE LAUNCHER LAU-115C/A PART NUMBERS 74A730351-1013 AND 74G730351-1015			
PART NUMBER	WP/FIGURE/ INDEX NUMBER	PART NUMBER	WP/FIGURE/ INDEX NUMBER
AIC-L-11V6-11	004 00 / 5/ 12 004 00 / 6/ 12 004 01 / 3/ 12	AIC-L-644-6-7	004 00 / 5/ 42 004 00 / 5/ 48 004 00 / 6/ 41
AIC-L-11V6-5	004 00 / 5/203 004 00 / 6/190 004 01 / 3/157 006 00 / 5/ 14 006 00 / 6/ 14 006 01 / 4/ 14	AIC-L-644-8-5	004 00 / 6/ 47 004 01 / 3/ 32 004 01 / 3/ 38 006 00 / 5/ 26 006 00 / 6/ 27 006 01 / 4/ 40
AIC-L-11V6-6	004 00 / 5/ 93 004 00 / 6/ 89 004 01 / 3/ 80 006 00 / 5/ 6 006 00 / 5/ 34 006 00 / 6/ 6 006 00 / 6/ 35 006 01 / 4/ 6 006 01 / 4/ 48	AIC763-4-22 AN316-4 AN565FC1032H3 AN565F1032H3 AN735D10 AN735D19	003 00 / 3/ 31 008 00 / 4/ 22 014 00 / 5/ 84 014 00 / 5/ 84 012 00 / 1/ 60 012 00 / 2/ 60 012 01 / 1/ 60 012 00 / 1/ 7 012 00 / 2/ 7 012 01 / 1/ 7
AIC-L-11V6-7	004 00 / 5/201 004 00 / 6/188 004 01 / 3/155	AN742D4 AN960-10L AN960-6L	014 00 / 5/ 16 005 00 / 2/ 66 014 00 / 5/ 12 014 00 / 5/ 18
AIC-L-11V6-8	006 00 / 5/ 9 006 00 / 5/ 41 006 00 / 6/ 9 006 00 / 6/ 42 006 01 / 4/ 9 006 01 / 4/ 55	AN960C10L	005 00 / 2/ 16 005 00 / 2/ 21 005 00 / 3/ 16 005 00 / 3/ 21
AIC-L-41-6-3	006 01 / 4/ 27		005 01 / 2/ 8
AIC-L-41-6-4	006 01 / 4/ 25 006 01 / 4/ 29 006 01 / 4/ 35	AN960C416	010 00 / 3/ 10 010 00 / 3/ 24 010 00 / 3/ 5

FIGURE B-18. Example of numerical index of part numbers work package.

MIL-STD-3001-1A(AS) w/CHANGE 1

APPENDIX B

AW-394AC-750-000**001 02**

1 February 1997

INTERMEDIATE AND DEPOT MAINTENANCE WITH ILLUSTRATED PARTS BREAKDOWN**NUMERICAL INDEX OF REFERENCE DESIGNATIONS****AIRCRAFT GUIDED MISSILE LAUNCHER LAU-115/A
PART NUMBERS 74A730351-1003 AND 74A730351-1007****AIRCRAFT GUIDED MISSILE LAUNCHER LAU-115A/A
PART NUMBERS 74A730351-1009 AND 74A730351-1011****AIRCRAFT GUIDED MISSILE LAUNCHER LAU-115C/A
PART NUMBERS 74A730351-1013 AND 74G730351-1015**

REF DES	WP/FIGURE/ INDEX NUMBER	REF DES	WP/FIGURE/ INDEX NUMBER	REF DES	WP/FIGURE/ INDEX NUMBER
GND7- W001	004 00/ 5/ 74	61B- W210-S3	014 00/ 5/ 69	61K- W211	012 00/ 2/107
61A- Y502	003 00/ 3/		014 00/ 5/ 69		012 01/ 1/ 98
	003 00/ 3/	61B- W210-S4	014 00/ 5/ 69	61K- W224	012 00/ 1/ 92
	003 00/ 3/		014 00/ 5/ 69		012 00/ 2/113
	003 00/ 3/	61J- W095A	012 00/ 1/ 47		012 01/ 1/104
	003 00/ 3/		012 00/ 2/ 47	61K- W225	012 00/ 1/ 92
	003 00/ 3/		012 01/ 1/ 47		012 00/ 2/113
61B- W210	007 00/ 4/ 24	61J- W095B	012 00/ 1/ 78		012 01/ 1/104
	007 00/ 4/ 24		012 00/ 2/ 78	61K- W226	012 00/ 1/ 88
	007 00/ 4/ 24		012 01/ 1/ 81		012 00/ 1/ 88
	014 00/ 5/	61J- W239	012 00/ 1/ 54		012 00/ 2/115
	014 00/ 5/		012 00/ 2/ 54		012 01/ 1/106
	014 00/ 5/		012 01/ 1/ 54	61K- W227	012 00/ 1/ 88
61B- W210-B1	014 00/ 5/ 37	61J- W253	012 00/ 2/ 86		012 00/ 1/ 88
61B- W210-E1	014 00/ 5/ 87		012 01/ 1/ 89		012 00/ 2/115
	014 00/ 5/ 87	61J- W254	012 00/ 2/ 86		012 01/ 1/106
61B- W210-S1	014 00/ 5/ 73		012 01/ 1/ 89	61K- W228	012 00/ 1/ 88
	014 00/ 5/ 73	61J- Y287	012 01/ 1/ 77		012 00/ 1/ 88
61B- W210-S2	014 00/ 5/ 73	61K- W211	012 00/ 1/ 90		012 00/ 2/113
	014 00/ 5/ 73		012 00/ 2/ 97		012 01/ 1/104

FIGURE B-19. Example of a numerical index of reference designations work package.

MIL-STD-3001-1A(AS) w/CHANGE 1

APPENDIX B

AW-394AC-750-000

1 February 1997

002 01**INTERMEDIATE AND DEPOT MAINTENANCE WITH ILLUSTRATED PARTS BREAKDOWN****CONSOLIDATED LISTS FOR TECHNICAL DIRECTIVES, SUPPORT EQUIPMENT,
MATERIALS, AND REFERENCES****AIRCRAFT GUIDED MISSILE LAUNCHER LAU-115/A
PART NUMBERS 74A730351-1003 AND 74A730351-1007****AIRCRAFT GUIDED MISSILE LAUNCHER LAU-115A/A
PART NUMBERS 74A730351-1009 AND 74A730351-1011****1-1. HISTORICAL RECORD OF APPLICABLE TECHNICAL DIRECTIVES.**

1-2. The Historical Record of Applicable Technical Directives is a list of all technical directives that have ever affected this manual. Current technical directives now affecting this manual are listed in the Record of Applicable Technical Directives of each affected work package. When a technical directive is rescinded, the before configuration is removed from the manual and the technical directive entry is removed from each affected work package.

Historical Record of Applicable Technical Directives

TD Type/Number	TD Date	Title and ECP/RAMEC Number	Date Incorporated	Remarks
AAC 855	31 May 91	Launcher Guided Missile Aircraft LAU-115/A, Modification of (ECP-MDA-F/A-18-00090C1)	1 Sep 84	
AAC 901	-	Missile Rail Launcher LAU-115A/A Relay/Diode Assembly, Addition of (ECP-MDA-F/A-18-00336R1)	15 Sep 92	
AAC 928	-	LAU-115A/A Missile Launcher AMRAAM Jettison Adapter, Installation of (ECP-MDA-F/A- 18-00422)	1 Jun 94	
IAAC 889	-	Positive Latch Addition to LAU-115/A Rail Launcher (ECP-MDA-F/A-18-00269R1)	15 May 88	

2-1. SUPPORT EQUIPMENT REQUIRED.

2-2. This list identifies all equipment required to support the procedures contained in the manual.

Support Equipment Required

Nomenclature	Part Number	CAGE Code
Shear Wafer, AIM-7 Dale Electronics	917AS8809 or 917AS9881 or QX32P-SW	09969
Socket, Spline Snap-On Tools Corp.	TES10	55719

3-1. MATERIALS REQUIRED.

3-2. This list identifies all materials required to support the procedures contained in the manual.

FIGURE B-20. Example of consolidated lists of technical directives, support equipment, materials, and references work package.

MIL-STD-3001-1A(AS) w/CHANGE 1

APPENDIX B

AW-394AC-750-000		002 01
Materials Required		
Nomenclature	Specification/Part Number	HMWS Index Number
Cloth, Cheesecloth	CCC-C-440 TYPE 1 CLASS 1	
Epoxy Primer Coating	MIL-P-23377 TY1	22
Epoxy Primer Coating	MIL-P-23377 TY2	22
Humidity Indicator Plug	MIL-I-26860, TYPE 2	
Lubricant, Solid Film	MIL-L-23398 TYPE 2	15
4-1. REFERENCE MATERIAL.		
4-2. This list identifies reference material required to support the manual.		
Reference Material		
Abbreviations for Use on Drawings, and in Specifications, Standards and		
Technical Documents.....		MIL-STD-12
Airborne Weapons and Associated Equipment.....		NAVAIR 01-1A-75
Aircraft Corrosion Control.....		A1-F18AC-SRM-500
Aircraft/Armament Monitor and Control.....		AE-199AG-580-000/(S)
Assignment and Application of Uniform Source, Maintenance, and		
Recoverability Codes.....		NAVAIRINST 4423.11
Aviation Supply Office Publications.....		P2300 (series)
Commercial and Government Entity (CAGE) Cataloging Handbook		H4/H6/H8
Distribution of NAVAIR Technical Publications		NAVAIRINST 5605.5A
2		

FIGURE B-20. Example of consolidated lists of technical directives, support equipment, materials, and references work package. - Continued.

MIL-STD-3001-1A(AS) w/CHANGE 1

APPENDIX B

NAVAIR 02B-105AH3-6-1

1 August 1996

002 02**INTERMEDIATE MAINTENANCE****MAINTENANCE ALLOCATION****ENGINE
SERIAL NO. 216001 AND SUBSEQUENT****Reference Material**

T58-GE-16 Maintenance Plan PMP-0007

1-1. INTRODUCTION.

1-2. This Work Package (WP) contains maintenance allocation information for Intermediate Maintenance Activities (IMA).

1-3. Maintenance allocation is divided into three maintenance levels - First degree, Second degree and Third degree. Table 1 lists the maintenance work which can be performed at each of these levels.

2-1. MAINTENANCE LEVEL DIFFERENCES.

2-2. Each maintenance level/degree is responsible for the functions of all lower level/degree maintenance. Maintenance levels/degrees at which specific maintenance function may be performed are defined in paragraphs 2-3 through 2-6.

2-3. FIRST DEGREE. This maintenance degree includes disassembly and repair to a depth which includes and goes beyond maintenance functions authorized for Second and Third Degree IMAs but not to the extent required to perform Depot Level Maintenance. First Degree Maintenance is Complete Engine Repair (CER) which includes capability of power turbine and compressor rotor replacement or disassembly to a degree that the power turbine rotor or compressor rotor assembly could be removed. Activities designated as First Degree Maintenance will be equipped to accomplish CER as well as lesser degrees of maintenance including incorporation of all technical directives (PPCs, PPBs, and SECs) below depot level of maintenance.

2-4. SECOND DEGREE. This maintenance degree includes restoration of a damaged or non-operating engine, its accessories or components to an acceptable operating condition, including repair or replacement of gas generator turbine rotor and combustion section. Also authorized is replacement of externally damaged, deteriorated or time-limited components, gearboxes, or accessories and conducting engine calendar (or equivalent) inspections. In addition, minor repair to the compressor section is authorized (replacement of compressor rotor blades with rotor installed and dressing nicks in compressor vanes and blades within limits specified in this manual).

Table 1. Breakdown of Engine Maintenance for Intermediate Level Activities

NOMENCLATURE	DEGREE OF INTERMEDIATE MAINTENANCE			FUNCTION	WP
	1	2	3		
FAN MODULE					
Fan Module	X			Assembly	056 00
	X			Disassembly	056 00
	X	X	X	Installation	027 00
	X	X	X	Removal	024 00
	X	X	X	Repair	056 00
Fan Stator Assembly	X			Assembly	059 00

FIGURE B-21. Example of a maintenance allocation work package.

MIL-STD-3001-1A(AS) w/CHANGE 1

APPENDIX B

NAVAIR 02B-105AH3-6-1

002 02

Table 1. Breakdown of Engine Maintenance for Intermediate Level Activities (Cont)

NOMENCLATURE	DEGREE OF INTERMEDIATE MAINTENANCE			FUNCTION	WP
	1	2	3		
	X			Disassembly	059 00
	X			Installation	056 00
	X			Removal	056 00
	X			Repair	056 00, 059 00
Fan Rotor Assembly	X			Installation	056 00
	X			Removal	056 00
	X			Repair	058 00
(Horizontal Maintenance)	X	X	X	Repair	062 00
Front Frame Assembly	X			Assembly	057 00
	X			Disassembly	057 00
	X			Installation	056 00
	X			Removal	056 00
	X			Repair	056 00, 057 00
(Horizontal Maintenance)	X	X	X	Repair	062 03
Fan Variable Geometry	X			Installation	056 00
	X			Removal	056 00
Fan Stator Case	X			Installation	056 00
	X			Removal	056 00
	X	X		Repair	056 00
No. 1 Bearing	X	X		Installation	056 00
	X	X		Removal	056 00
Fan Stages 1, 2, and 3 Vanes	X			Installation	059 00
	X			Removal	059 00
Inlet Guide Vanes	X	X		Installation	057 00
	X	X		Removal	057 00
Stage 1 Fan Rotor Blades	X	X		Installation	058 00
	X	X		Removal	058 00

FIGURE B-21. Example of a maintenance allocation work package. - Continued.

MIL-STD-3001-1A(AS) w/CHANGE 1

APPENDIX B

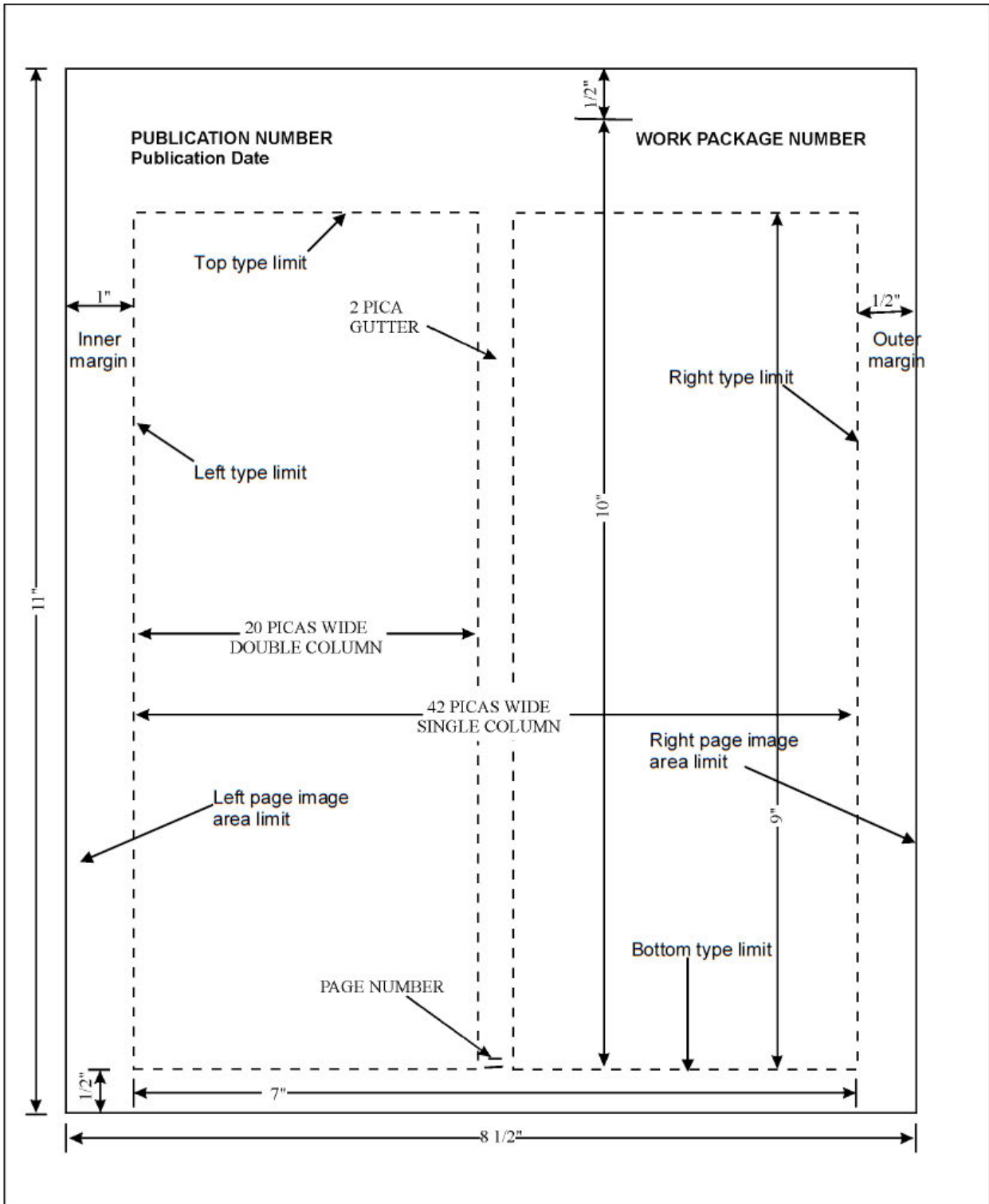

FIGURE B-22. Example of a page image area.

MIL-STD-3001-1A(AS) w/CHANGE 1

APPENDIX B

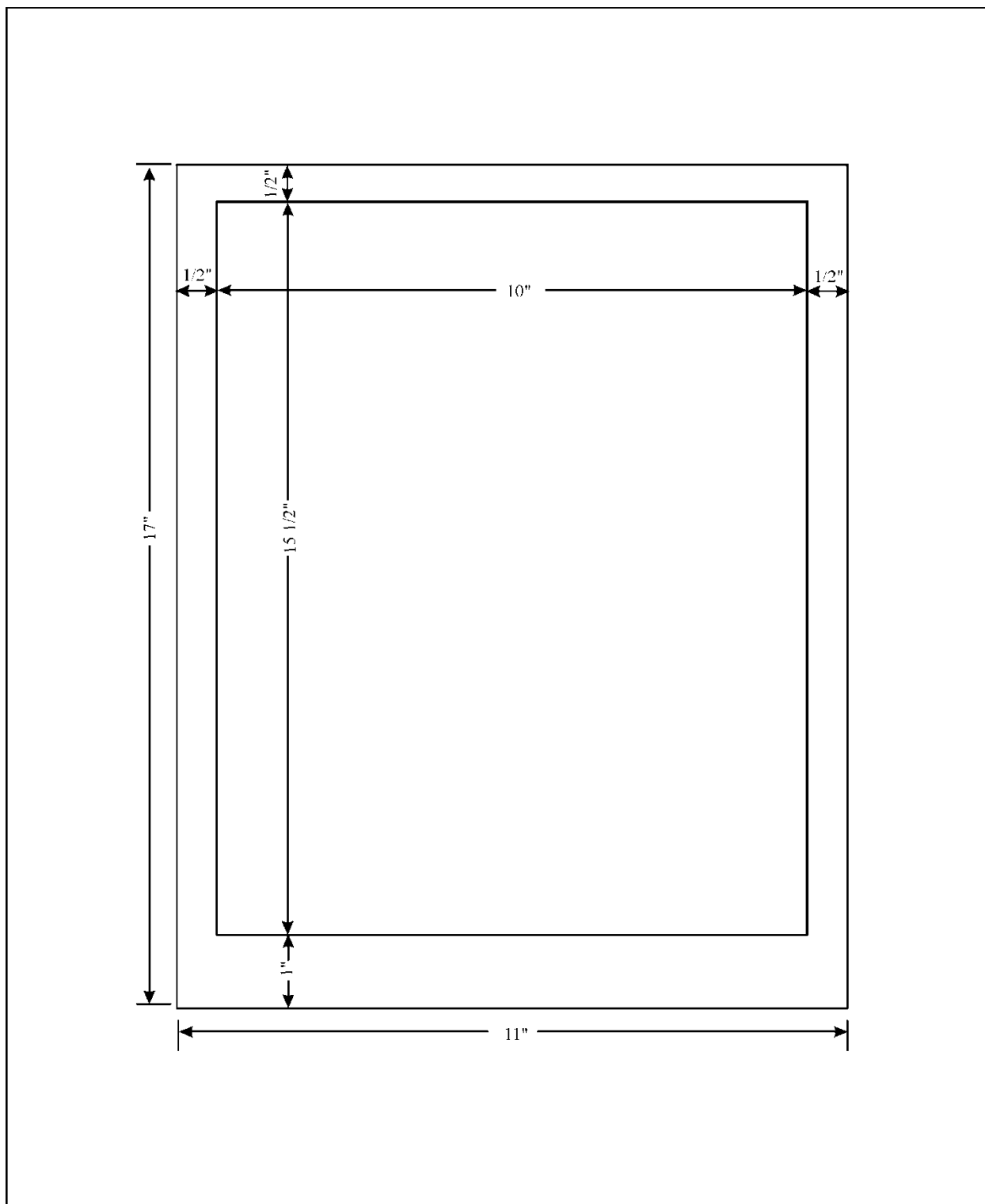

FIGURE B-22. Example of a page image area. - Continued.

MIL-STD-3001-1A(AS) w/CHANGE 1

APPENDIX C

APPENDIX C - PREPARATION REQUIREMENTS FOR INTERACTIVE ELECTRONIC TECHNICAL MANUALS**C.1 SCOPE**

C.1.1 Scope. This appendix establishes the style and format requirements for the display of Interactive Electronic Technical Manuals (hereafter referred to as IETMs) required to operate and maintain the various types of equipment and weapon systems within the Department of the Navy. IETMs are digital in form and designed for interactive display to maintenance technicians or system operator by means of a computer controlled Portable Electronic Maintenance Aid (PEMA). This Appendix is a mandatory part of the standard. The information contained herein is intended for compliance.

C.2 APPLICABLE DOCUMENTS

The applicable documents in Section 2 of MIL-STD-3001-1 apply to this appendix.

C.3 DEFINITIONS

The definitions in Section 3 of MIL-STD-3001-1 apply to this appendix.

C.4 GENERAL REQUIREMENTS

C.4.1 General. The mandatory style and format requirements provided in this appendix supplement the technical content requirements in the other parts of this 8-part standard. These requirements shall apply for the presentation of TM information in either a linear, scrollable or interactive, frame-based format on a computer display.

C.4.2 Development of work package IETMs. A WP IETM is specifically designed to support individual functional information or maintenance work tasks for a weapon system or equipment. TM data developed for IETMs shall be prepared in accordance with the requirements of MIL-STD-3001-1 through MIL-STD-3001-8. TM data shall be tagged using Extensible Markup Language (XML). This is accomplished by applying the applicable MIL-STD-3001-1 Document Type Definitions (DTDs). The DTDs interpret the technical content and structure of the functional requirements provided in MIL-STD-3001-1 through MIL-STD-3001-8. The DTDs are mandatory for use. The use of a specific style sheet will dictate the style and format as it appears on the display device. Style sheets shall be developed using the style and format requirements contained in this appendix.

C.4.2.1 Use of style sheets. The style and format of IETMs prepared in accordance with MIL-STD-3001-1 through MIL-STD-3001-8 are predefined using the style sheets developed for the NAVAIR Standard Interactive Electronic Technical Manual (IETM) Viewer (NSIV). The NSIV style sheets are based on the common look and feel (style and format) requirements provided in NAVAIRINST 4120.11.

C.4.2.2 Use of a viewer other than NSIV. For IETMs prepared in accordance with MIL-STD-3001-1 through MIL-STD-3001-8 that do not use the NSIV, development of style sheets in

MIL-STD-3001-1A(AS) w/CHANGE 1

APPENDIX C

accordance with NAVAIRINST 4120.11 common look and feel requirements will be required so that IETMs can be displayed on a suitable Portable Electronic Maintenance Aid (PEMA).

C.4.3 IETM definitions.Linear structured IETM. Interactive display of technical information which is marked-up (i.e., XML, SGML tagged, etc.) in accordance with a DoD approved IETM development standard and using a Hypertext presentation system for display. It is based on a linear document structure and not a hierarchically based data base.

C.4.3.2 Hierarchical structured IETM. Interactive electronic display of technical information specifically authored into and maintained in a non-redundant relational or object-oriented hierarchical data base. Data is packaged as a run-time data base for interactive frame-based presentation in accordance with the IETM specifications.

C.4.3.3 Integrated process IETM. Systems for interactive electronic display of the hierarchical structured IETMs described above, integrated with other processes including expert-system rules for the display of information designed to be displayed by those rules or processes and other user-applications such as diagnostics or computer-managed training. This type of IETM is intended to include future applications and features not yet developed or sufficiently mature for production use.

C.4.3.4 Other types of IETMs. In addition, thousands of paper legacy weapon systems TMs have already been converted to a digital form and classified as IETMs. These IETMs can be displayed on a computer screen but provide only a minimum of interactive or navigational capability. These IETMs are divided into two basic types:

a. Page-Image IETMs. Digitized page images of the existing legacy TM (Intelligent raster or Postscript format) intended for full page display using an automated intelligent index to the page images for user interaction.

b. Page-Oriented Hypertext IETMs. Interactive display of ASCII-encoded, page-oriented documents using an intelligent index and hypertext tags inserted into a tagged document file. This type of an IETM allows the user to navigate through the manual based on the amount of author-generated links provided in the document file.

C.5 DETAILED REQUIREMENTS

C.5.1 General. The style and format of IETMs prepared in accordance with MIL-STD-3001-1 through MIL-STD-3001-8 are predefined using the style sheets developed for the NSIV and are based on the common look and feel requirements (style and format) provided in NAVAIRINST 4120.11. For IETMs prepared in accordance with MIL-STD-3001-1 through MIL-STD-3001-8 that do not use the NSIV viewer, development of style sheets in accordance with NAVAIRINST 4120.11 common look and feel requirements will be required so that IETMs can be displayed on a suitable PEMA.

C.5.1.1 Level of detail. IETMs shall be authored and displayed to a level of detail suitable for the novice user. In this usage, novice means a technician with the lowest level of experience and

MIL-STD-3001-1A(AS) w/CHANGE 1

APPENDIX C

training who will be minimally qualified to perform and be assigned the functions described by the IETM. All IETM procedures shall be written for the novice technician level.

C.5.2 IETM divisions. The hierarchy of an IETM consists of front matter and a series of WPs that include the types of data listed below:

a. Supporting information. Supporting information includes information such as the Hazardous Materials Warnings Summary; Historical Record of Applicable Technical Directives; Consolidated Lists of Support Equipment, Materials, and References; Numerical Index of Part Numbers; Numerical Index of Reference Designations; Maintenance Allocation (**engines intermediate maintenance only**); and Safety Summary (**training systems only**). Supporting information is divided into the support-oriented WPs that are required to supplement or complement the technical information and task-oriented WPs developed in accordance with MIL-STD-3001-1 series.

b. Descriptive information. Descriptive information provides information on how system, subsystem, and components function or operate and is intended to provide the user with an understanding of the system process. This information may consist of physical arrangement, functions, processing, theory of operation, modes of operation, built-in-test (BIT), controls, indicators, and displays.

c. Testing and troubleshooting information. Testing and troubleshooting (fault isolation information) is the data necessary to isolate faults found in a system, equipment, or component. Fault data basically contains outcomes, faults, and corrective actions.

d. Procedural information (operator and maintenance tasks). Procedural information is primarily corrective or scheduled maintenance procedures, such as adjustment, servicing, inspection, removal, installation, and repair.

e. Parts information. Parts information is the necessary information required to identify and order a new part, generally called illustrated parts breakdowns (IPBs).

C.5.3 Front matter. The following IETM front matter is necessary to supplement the technical content WPs:

- a. CD label and flyleaf data (if applicable).
- b. Title page data.
- c. Revision summary data.
- d. Table of contents.
- e. "How To Use This IETM" information.
- f. Acronyms and abbreviations list.
- g. Effectivity information.

MIL-STD-3001-1A(AS) w/CHANGE 1

APPENDIX C

C.5.3.1 CD label and flyleaf data. The CD-ROM shall have a label and flyleaf prepared in accordance with NAVAIR 00-25-604.

C.5.3.2 Title page data. Title page requirements are identical to the title page requirements for page-based printed and screen displayed PDF TMs provided in Appendix B (refer to [B.5.3.1.1](#)).

C.5.3.3 Revision summary data <revision-summary-info>. When a revision to an IETM is issued, a revision summary should be provided. The revision summary shall contain a list of WPs by title <title> that have been revised and for each WP listed, a brief description <desc> of the major changes shall be provided. The titles of revised WPs listed in the revision summary shall be linked to the WP containing the revised information.

C.5.3.4 Table of contents. A table of contents shall be prepared. Official nomenclature from the parts information should be used. The subject matter should be listed by system/subsystem and equipment. To facilitate access, subsystems, subassemblies, installations, and individual components may be indented and listed under the main system. Further subdivisions should be included to list all descriptive, operation, troubleshooting, and maintenance tasks for each of the system/subsystem, equipment, subassemblies, and individual components included in the IETM. When displayed, the table of contents should provide a search capability. All entries in the table of contents should be linked to the actual subject matter in the WPs.

C.5.3.4.1 Display of the table of contents. The subject matter shall be in alphabetical order first by system/subsystem and equipment. Subsystems, subassemblies, installations, and individual components indented and listed under the main system should be in alphabetical order. The table of contents should be displayed in accordance with the style and format requirements provided in NAVAIRINST 4120.11.

C.5.3.4.2 Use of work package numbers. WPs are assigned numbers in accordance with the requirements provided in Appendix B, [B.5.4.7.13.4](#). WP numbers are required for quick reference capability in printed and PDF formatted TMs. WP numbers are not required for IETMs and are therefore suppressed and not displayed when an IETM is viewed.

C.5.3.5 "How to Use this IETM" information <how-to-use-etm>.

a. Information to familiarize the user with special or unusual features of the IETM should be prepared. Coverage should lead the user through the IETM and explain important features of the organization and content. For example, the format is explained; operating and troubleshooting information are explained; and repair, maintenance instructions, and other pertinent information are explained.

b. Any peculiarities in the basic structure of the IETM should be described. "How to use" information should not repeat instructions given within the WPs.

c. For all IETMs (excluding operators) the "how to use" information should include an explanation on how and where parts information is available in the WPs, how the parts information is accessed, and if applicable, how the parts can be ordered.

MIL-STD-3001-1A(AS) w/CHANGE 1

APPENDIX C

d. For troubleshooting, an explanation on how troubleshooting data is presented in the IETM should be included. If applicable, an explanation on how failure symptom indexes and malfunction codes correspond to maintenance operational checks and troubleshooting procedures for individual systems and components should be included.

e. An explanation should be included on how to identify hotspots and how they are used and activated.

f. If a double king sized, paged-based, paper TM containing the supporting schematic and wiring diagrams has been authorized and developed, a reference to this TM by TM number should be provided.

g. When a standard form must be used in the process of performing a task, instructions should be provided on how these forms are accessed, used, and filled out.

C.5.3.5.1 Display of "How to Use This IETM" information. "How to Use This IETM" information is prepared in narrative format and shall be displayed in accordance with the look and feel requirements (style and format) provided in NAVAIRINST 4120.11.

C.5.3.6 Acronyms and abbreviations list <abbrevlist>. A consolidated list of abbreviations, acronyms, and uncommon terms shall be developed explaining all abbreviations, acronyms, and unusual terms used in the IETM.

C.5.3.7 Effectivity information. If applicable, an explanation of the effectivities used throughout the TM may be included in a consolidated list of effectivity information <consoleffectlist>. A standard table shall be used to indicate configuration (effectivity) differences. If used, the standard table shall include an Effectivity Legend <effectlegend> column containing the legend that will be used throughout the WP text to consolidate or shorten the configuration identification. The legend shall use usable on code letters or numbers <effectcode> and shall appear within a box. In lieu of boxed letters or numbers, a graphic representation may be used to represent effectivity. Do not combine more than one number or letter in a legend box unless it results in significant page reduction. The second column, Configuration Identification <config>, shall list the actual configuration represented by the legend, such as tail numbers, BuNos, model numbers, serial numbers, part numbers, technical directive numbers, etc., covered by the TM. The third column, **Remarks <remarks>**, shall be a column required for any relative information about the configuration data, such as an ECP or AVC incorporated.

C.5.4 Supporting information work packages <supportinfo>. Supporting information shall be logically subdivided into the support-oriented WPs that are required to supplement or complement the technical information and task-oriented WPs. The information may be displayed in tables and lists or linked to the specific row(s) in the table or item(s) in a list instead of displaying the entire table or list. If the entire table or list is displayed, the table or list shall be scrollable. Supporting information includes:

MIL-STD-3001-1A(AS) w/CHANGE 1

APPENDIX C

- a. Hazardous materials warning summary.
- b. Consolidated numerical index of part numbers.
- c. Consolidated numerical index of reference designations.
- d. Historical record of applicable technical directives.
- e. Consolidated lists of support equipment, materials, and references.
- f. Maintenance allocation, as applicable (**engine intermediate maintenance only**).
- g. Safety summary, as applicable (**training systems only**).

C.5.4.1 Hazardous Materials Warning Summary (HMWS) <hmwswp>. The complete warnings applicable to hazardous materials and related information shall be prepared. The acronym "HMWS" shall be used to identify the warning information. The warnings shall be developed from information provided by chemical manufacturers in material safety data sheets (MSDS) required by 29 CFR 1910.1200.

C.5.4.1.1 Explanation of hazardous materials icons. Each of the nine authorized icons, with related explanation, shall be provided. Immediately following the explanations, complete warnings shall be listed for all hazardous materials used in the manual.

C.5.4.2 Consolidated numerical index of part numbers work package <partnoindxwp>. This WP shall contain a complete list of part numbers consolidated from all WPs containing group assembly parts lists (GAPLs). The primary purpose of this index is to provide direct linking to the WPs related to a specific part number. The list shall be prepared as described below:

- a. For all maintenance manuals, parts contained in the maintenance WP GAPLs or separate IPB WPs shall be listed by part number.

- b. All part numbers listed in the GAPL part number column of every IPB figure contained in the maintenance WPs or separate IPB WPs shall be listed except for attaching parts. Attaching parts may be listed but are not mandatory. Superseded parts that have continued application shall be listed. Part numbers shall be listed in alphanumeric sequence as follows:

- (1) First position of the part number in order of precedence: the letters A through Z, the numerals zero through nine.

- (2) Second and succeeding positions of the part number in order of precedence, from left to right: space (blank position), diagonal (/), point (.), dash (-), letters A through Z, and numerals zero through nine.

- (3) Items without part numbers (listed with a dash (-) in the GAPL part number column) shall be listed alphabetically, using the identifying noun in lieu of a part number.

C.5.4.3 Consolidated numerical index of reference designations work package <refdesindxwp>. This WP shall contain a complete list of reference designations consolidated from all WPs

MIL-STD-3001-1A(AS) w/CHANGE 1

APPENDIX C

containing GAPLs. The primary purpose of this index is to provide direct linking to the WP related to a specific reference designation.

a. All parts listed with a reference designation contained in the maintenance WP GAPLs or separate IPB WPs shall be listed.

b. Reference designations shall be listed in reference designation sequence.

C.5.4.4 Historical record of applicable technical directives <hrtad>. A consolidated historical list of the technical directives (**standard list**) applicable to all WPs shall be prepared. The historical record of technical directives shall be prepared in accordance with MIL-STD-3001-4.

C.5.4.5 Consolidated list of support equipment required <sreq>. A list of support equipment and special tools required (**standard list**) to perform the operational checkout, troubleshooting, and maintenance procedures contained in all WPs shall be prepared. The list shall be prepared in accordance with MIL-STD-3001-4 and the following additional requirements:

a. Total quantity. The total quantity is not applicable to the consolidated list of support equipment.

b. Alternate items. If an alternate item can be used, it shall be listed below the prime item to which it applies and shall be indented.

(1) Alternate item nomenclature is not required to match the prime item.

(2) The term "or equivalent" shall not be used to identify alternate part numbers.

(3) The requirement to list alternates shall not be interpreted to mean the preparing activity shall perform research to include such alternates.

(4) If information on an equivalent item is passed to the preparing activity for inclusion in the WPs, the item shall be listed as required above.

C.5.4.6 Consolidated list of materials required <matreq>. A list of all materials (consumable materials and/or expendable items) (**standard list**) required to perform maintenance type procedures contained in all WPs shall be prepared. The list shall be prepared in accordance with MIL-STD-3001-4, except the total quantity is not applicable to the consolidated list of materials required.

C.5.4.7 Consolidated list of reference material <refmat>. A complete list of reference material (**standard list**) consolidated from all technical content WPs shall be prepared. The list shall be prepared in accordance with MIL-STD-3001-4.

C.5.4.8 Maintenance allocation work package <maintalwp> (engine intermediate maintenance only). This WP shall include identification of tasks applicable to each degree of intermediate maintenance for the engine and its assemblies and components. A table (**standard table**) shall be developed identifying "1st," "2nd," and "3rd" for each degree of intermediate maintenance. The WP shall also include an explanation of the maintenance allocation headings

MIL-STD-3001-1A(AS) w/CHANGE 1

APPENDIX C

and a statement that allowable maintenance shall be consistent with spare parts provisioning, support equipment and maintenance site capability and that if these conditions are not met, the engine shall be declared beyond capability of maintenance (BCM) and shall be transferred to a maintenance activity having repair capability in accordance with COMNAVAIRFORINST 4790.2.

C.5.4.9 Safety summary work package <safetywp> (training systems only). When applicable, a safety summary WP shall be prepared for TMs containing warnings and cautions. The safety summary is not a word-for-word repetition of all the precautions in the TM and should be limited to alerting the user of the different types of hazards, in general terms, that will be encountered in operating and maintaining the training system or equipment covered within the TM.

C.5.5 Style, format and display of work packages. The style, format and display of WPs shall be in general accordance with NAVAIRINST 4120.11 and the requirements provided below.

C.5.5.1 Work packages. WPs are used to logically divide all data required for a certain function (i.e., descriptive information, operator's instructions, maintenance with IPB, troubleshooting, etc.). These data types can be further divided into tasks, subtasks (procedures), paragraphs; procedural steps; tables; lists; warnings, cautions, and notes; and supporting graphics, etc. Parts information shall be accessible in any of the data types, as necessary.

C.5.5.1.1 Work package content. Each WP shall consist of WP title block information, WP initial setup information, and the specific data necessary to develop the types of technical content WPs described in MIL-STD-3001-2 through MIL-STD-3001-8.

C.5.5.1.2 Work package title. Each WP shall have a title that identifies the general subject or maintenance or troubleshooting task contained in the WP. The title shall be identical to the title in the table of contents.

C.5.5.1.3 Work package initial setup information. WP initial setup information shall be included for each WP, as required by MIL-STD-3001-2 through MIL-STD-3001-8.

C.5.5.2 Work package text and graphics. The style and format of WP text and graphics shall be in general accordance with the common look and feel requirements provided in NAVAIRINST 4120.11 and the requirements provided below.

C.5.5.2.1 Abbreviations and acronyms. Abbreviations, acronyms, and unusual terms may be used in any WP text, when applicable. It is not necessary to spell out the words completely after the first use of an acronym or abbreviation. Hotspots should be used to link all abbreviations, acronyms, and uncommon terms to the WP containing the complete explanation and listing of abbreviations, acronyms, and uncommon terms.

C.5.5.2.2 Nomenclature.

C.5.5.2.2.1 Nomenclature consistency. Nomenclature of identical systems, subsystems, equipment, support equipment, components, and parts of the end item shall be consistent throughout the manual. The preparing activity shall develop nomenclature lists for associate

MIL-STD-3001-1A(AS) w/CHANGE 1

APPENDIX C

preparing activities to ensure consistency throughout the WPs. The correct nomenclature shall be derived from one of the following sources (listed in the order of precedence):

- a. "AN" nomenclature,
- b. Nameplate nomenclature,
- c. H-6 assigned nomenclature, or
- d. Nomenclature on the drawing from which the item was manufactured.

C.5.5.2.2.2 Noun modifiers. Noun modifiers should be added to the description of parts as required to assure positive identification, such as cotter pins/taper pins. These modifiers need not appear on the preparing activity's graphic. Noun modifiers, once added for clarity, shall be used throughout the technical data.

C.5.5.2.2.3 Military terms. Military terms used shall be in accordance with Joint Pub 1-02, or any approved dictionary or glossary of Navy military terms.

C.5.5.2.2.4 Automatic electronic test and checkout terminology. Terms used for automatic electronic test and checkout shall be in accordance with MIL-STD-1309.

C.5.5.2.2.5 Placard data. If all or a portion of the name of a control or display appears as a label on the equipment, that portion shall be written exactly as on the label, except that the placard shall be written in all capital letters to distinguish it from surrounding text, e.g., "POWER switch" or "MAIN PWR circuit breaker." It is also permissible to spell out the word for a symbol that cannot be reproduced by the equipment used to prepare the data.

C.5.5.2.2.6 Designation of equipment. The official designation of equipment shall be expressed in specific terms such as model number, type, serial number range, or similar terms. Nomenclature corresponding to that appearing on the equipment in the form of nameplates, decals, engraved legends or other markings shall be stated in text using the same wording that appears on the hardware.

C.5.5.2.3 National stock numbers. National stock numbers shall not appear in WPs but may be included in the parts data information (refer to MIL-STD-3001-4).

C.5.5.2.4 Part numbers. Part numbers shall not be used in text or on illustrations except when necessary for clarity.

C.5.5.2.5 Symbols. When new or unusual graphics symbols are required, they shall be identified at each occurrence. It is permissible to spell out symbols that cannot be reproduced on the equipment on which the data is being prepared.

C.5.5.2.6 Footnotes. Footnotes shall not be used. A note shall be used in lieu of a footnote. There shall be an identifiable indication, such as an icon, to indicate the presence of a note.

MIL-STD-3001-1A(AS) w/CHANGE 1

APPENDIX C

C.5.5.2.7 References. The use of references in text can create undue hardship and/or confusion for the user of the technical data. References shall be kept to a minimum. A high amount of referencing in text frequently indicates improper task analysis or LSA/LMI. As a practical consideration, linking shall be used. Hotspots shall be used to link cross-referenced material.

a. Reference shall not be made to coverage contained in a higher maintenance level WP or NAVAIR manual from a lower maintenance level WP or NAVAIR manual (i.e., from an OMM to an IMM).

b. Reference shall not be made to coverage contained in other than NAVAIR manuals, except when the manual has been formally assigned a NAVAIR publication number.

NOTE

Commercial or joint usage manuals must be formally reviewed and approved for use prior to use by NAVAIR activities. When approved, the manuals are assigned NAVAIR publication numbers. Information related to review, approval and assigned number status can be provided by the requiring activity. The NAVAIR number is normally added during the next update of the manual and may not be listed in existing copies of the manual. Clarification can be provided by the requiring activity.

C.5.5.2.7.1 Mandatory compliance maintenance procedures. Mandatory compliance maintenance practices contained in NAVAIR general series manuals shall be referenced or linked (e.g., Aviation Hydraulics, Aviation Hose and Tube Repair, Cleaning and Corrosion Control, etc.).

C.5.5.2.7.2 Maintenance procedures contained in other manuals. Maintenance procedures that are required to complete maintenance tasks that are contained in another maintenance manual shall be referenced or linked by publication number.

C.5.5.2.7.3 Tasks performed by other work centers. Procedures that require performance of tasks by technical personnel other than those normally assigned to the subject task shall be referenced or linked in the WP title data and in the text. For example, if the primary task is removal of a component of the flight control system that is inaccessible without removal of the power plant, a preparatory step of the procedure would be, "Remove power plant (A1-F77AA-220-300)."

C.5.5.2.7.4 Post maintenance action referencing. When the last step of a maintenance task has been completed, any post maintenance actions required to ensure that the maintenance task has been successfully completed shall be included and linked. For example:

a. The last step of an installation procedure shall reference and link testing (Operational Checkout) or a required maintenance action, e.g., "Service hydraulic system," when the maintenance procedure (installation of a hydraulic system component) required an open line.

MIL-STD-3001-1A(AS) w/CHANGE 1

APPENDIX C

b. The last step of a required maintenance action shall reference and link testing (Operational Checkout) or an additional required maintenance action, e.g., such as when a hydraulic actuator is replaced.

C.5.5.2.7.5 References to other manuals or volumes. References in the text shall be made by the referenced task title as follows:

- a. For non-WP concept publications, reference shall be made by publication number.
- b. For WP format publications, reference shall be made by publication number only.
- c. Reference shall not be made to a paragraph or table number.
- d. When reference is made to a classified supplement and the discussion is incomplete without the data contained in the supplement, the classified supplement shall be listed under the "Reference Material" list at the beginning of the WP. The reference to the classified supplement shall include the classification of the classified supplement.
- e. Reference to another IETM shall be by the IETM publication number and the task title.

C.5.5.2.7.6 Referencing within the IETM. When it becomes necessary to reference to other WPs, descriptive information, maintenance tasks, or other data within the same IETM, it shall be by title. The title shall be the same used in the table of contents. A hotspot icon shall be used to indicate a link to the referenced data.

C.5.5.2.8 Equations. The use of equations shall be held to the minimum use required by the needs of the IETM user. The MATHPACK 911001 DTD should be used for preparing equations. The use of some equations may be limited by the Mathpack and the output system.

C.6 GRAPHICS REQUIREMENTSDisplay of illustrations. Illustrations shall be displayed on the user's PEMA in accordance with NAVAIRINST 4120.11. Figure titles for illustrations shall be used so that the figure title is displayed in the list of figures. (Refer to [Appendix D](#) for guidelines and typical examples of types of graphics that can be prepared for IETMs.)

C.7 REVISIONS AND UPDATES

C.7.1 Revisions and updates. When changes to IETMs are ordered, the deliverable product shall be either an update or a complete revision. The requiring activity will determine the type and frequency of the change required.

C.7.1.1 Revisions. A complete IETM revision requires rewrite of the technical content of the data to ensure that all new data and past updates are included. When applicable all existing change numbers, highlighting, change bars, dates, and change symbols shall be removed. When required by the requiring activity, a revision summary shall be provided (refer to [C.5.3.3.](#)) Revisions shall be incremental and the frequency of revisions will be defined in the contract. Each revision to an IETM shall be identified by a revision date.

MIL-STD-3001-1A(AS) w/CHANGE 1

APPENDIX C

C.7.1.2 Updates. Updates are changes to the initial version of the IETM or to the latest complete revision of an IETM. Updates are issued incrementally as necessary, or as required by the contract. When authorized by the requiring activity, updates shall include change symbols, highlighted text and change dates to inform the user what has changed and where the changes or additional information is located. When required by the requiring activity, a revision summary shall be provided (refer to [C.5.3.3](#)).

C.7.1.3 Change data/symbols. When authorized by the requiring activity, the following methods shall be used to identify technical changes in text, illustrations, and tables.

a. Text and tabular data. The titles of revised WPs listed in the revision summary shall be linked to the WP containing the revised information. Changes to text and tabular data shall be indicated by highlighting. Change symbols shall not be used.

b. Illustrations. Change symbols for illustrations shall be as follows:

(1) Miniature pointing hand. A miniature pointing hand shall be used to highlight the area containing the changed material.

(2) Alternate method. An acceptable alternate method for use with an extensively changed illustration is the use of the words "MAJOR CHANGE" enclosed in a box. The enclosed words shall be placed in a clear space in the lower left corner of the illustration image area.

(3) A change bar may also be used to indicate changed text within an illustration (e.g., list, legend).

C.8 COMPREHENSIBILITY

IETMs shall be written for the target audience. Reading grade level shall be as specified by the requiring activity.

C.9 SECURITY CLASSIFICATION REQUIREMENTS AND MARKINGS

C.9.1 Classified IETMs. SECNAV M-5510.36, provides regulations and guidance for classifying and safeguarding classified information. NAVAIR 00-25-100, provides additional requirements for identifying security classifications of IETMs.

C.9.2 Security classification markings. When preparation of a classified IETM is specified by the requiring activity, the security classification markings shall be identified in accordance with DoDM 5200.01-Volume 1 through Volume 4, DoD 5220.22M, SECNAV M-5510.36, and Executive Order 13526. For guidance on security classification and handling restrictive markings on Compact Disk-Read Only Memory (CD-ROM), refer to DoDM 5200.01-Volume 2.

C.9.2.1 Display of security classification markings. Whenever classified information is displayed, the classification markings shall be in accordance with NAVAIRINST 4120.11.

MIL-STD-3001-1A(AS) w/CHANGE 1

APPENDIX D

APPENDIX D - GRAPHICS GUIDELINES AND EXAMPLES OF TYPES OF GRAPHICS USED IN WORK PACKAGE TECHNICAL MANUALS**D.1 SCOPE**

D.1.1 Scope. This appendix provides guidelines for the preparation of graphics used in the development of page-based and screen displayed PDF TMs and IETMs. Also provided are examples of the various types of graphics. This Appendix is a mandatory part of the standard. The information contained herein is intended for compliance.

D.2 APPLICABLE DOCUMENTS

This section is not applicable to this appendix.

D.3 DEFINITIONS

This section is not applicable to this appendix.

D.4 GENERAL REQUIREMENTS**D.4.1 Illustration preparation.**

D.4.1.1 Requirements for digital graphics files. All graphics developed in accordance with this standard shall be delivered in one of the three graphic formats: Computer Graphic Metafile (CGM) format in accordance with MIL-PRF-28003, Continuous Acquisition and Life-cycle Support (CAL S) Raster format in accordance with MIL-PRF-28002, or Initial Graphics Exchange Specification (IGES) format in accordance with MIL-PRF-28000. Other commercial graphic formats may be acceptable if approved by the requiring activity.

a. The CGM file format is the preferred graphics file format.

b. All graphics files for a particular TM should be supplied in the same graphics format if practical. Otherwise, files should be delivered in any combination of the allowable formats.

D.4.1.2 Illustration style and format preparation. Plan, layout, and size illustrations to effectively portray the required details, and prepare illustrations to the latest technical data.

D.4.1.2.1 Illustrations for the support of procedural data. Illustrations developed to support operator or maintenance procedures shall not contain the text steps on the illustration (in the figure area).

a. Illustrations for procedures should supplement the text by clarifying procedures that are of a special nature or are not obvious.

b. Locate illustration(s) and foldout(s) at the end of each WP. For IETMs, illustrations should be linked to the applicable text step(s).

MIL-STD-3001-1A(AS) w/CHANGE 1

APPENDIX D

c. It is not necessary to illustrate each step of a maintenance procedure, such as the removal of screws with an ordinary screwdriver, lifting off a cover after the screws have been removed, etc.

D.4.1.2.2 Multiple use of illustrations. Whenever possible, one illustration should be used in support of two or more requirements. For example, illustrations prepared to support the parts list data shall be used to support the maintenance procedures contained in the same maintenance WP. However, additional illustrations may be developed to support the maintenance procedures if the parts list illustration does not adequately provide the guidance to perform the maintenance procedures.

D.4.1.2.3 Illustration preparation for tools and test equipment. Only uncommon or unusual uses and connections of tools and test equipment for test purposes shall be illustrated if it is essential to do so to avoid misunderstanding. Unusual operations should also be illustrated. Standard tools and test equipment are not illustrated, nor should self-evident or generally known uses be shown.

D.4.1.2.4 Electronic items.

a. Exploded views should not be used to identify electronic items such as components on circuit cards that are not to be disassembled for repair (see [figure D-1](#)). Index numbers should not be stacked (i.e., showing the index numbers next to a bar at the end of a leader line) unless each item and the index number are shown in a detailed view elsewhere on the illustrations.

b. Tables may be used rather than index leader lines to provide clarity. The table(s) should be part of the figure and not part of the textual data. For GAPL illustrations, the reference designators for electronic items should cross-reference the index numbers used in the associated parts list.

c. Applicable reference designators are placed next to the index number.

d. For IETMs, electronic parts should be linked to their applicable parts data.

D.4.1.3 Illustration detail and size.

D.4.1.3.1 Illustration detail. Style and techniques shall be of a quality that will produce illustrations that will clearly, adequately, and economically portray the information to be illustrated. The amount of detail should be limited to that required to support the content of the illustration.

a. When text alone is not adequate, supplement the text by using illustrations for depicting procedures such as disassembly, assembly, removal, and installation. In addition, illustrations are used to describe an item, process, or procedure; call attention to details; and provide identification of assemblies, parts, and tools, etc. Number or nomenclature callouts can be used to key important items in the illustration to the text.

b. Present illustration views so that the TM user can best understand the text being supplemented. In most instances this will be as the user would view the item in the performance of the associated task. In some cases, however, depicting the procedure or location of parts and

MIL-STD-3001-1A(AS) w/CHANGE 1

APPENDIX D

controls described in a procedure would better serve the user if shown as viewed from a different position.

- c. For IETMs, refer to NAVAIRINST 4120.11, for additional requirements.

D.4.1.3.2 Line drawings quality. Line drawings must be of high reproduction quality.

- a. Primary lines that create the basic outline (object line) of the drawing components shall have sufficient density (darkness), line weight, and sharpness to accommodate reproduction. Line width shall be in accordance with ANSI Y14.2. When electronically or optically reproduced, the primary lines should require no additional graphic enhancement.

- b. Secondary lines, such as those used to indicate extensions or measurements, are lighter than primary lines, but strong enough to reproduce clearly at the required reproduction size.

- c. Shading may be used to give substance and form to the item depicted, to sharpen the contrast between the subject and its background, or to increase effectiveness.

- (1) Shading and shadows are used only when necessary to provide a clear understanding of form, shape, or depth.

- (2) Shading effects are not to be used for decorative purposes.

- d. Accented lines may be used to emphasize detail when necessary.

- e. For page-based TMs, lined, cross-hatching, or mechanical patterns used instead of color shall remain clearly defined on the direct image copy (refer to D.5.1.10.18.7).

- f. Parallel lines on diagrams/schematics shall be no less than 1/16-inch apart when reduced to printed size.

D.4.1.3.3 Scale. Illustrations shall be prepared to as small a scale as possible consistent with effective portrayal of the graphic with all essential detail clear and legible. If prepared oversize, the illustration shall meet all requirements stated herein after reduction to the proper image size. Although not recommended, the vertical dimension of 1/4- and 1/2-page illustrations may be exceeded. The horizontal dimension shall not be exceeded. The desired sizes of illustrations for 8 1/2 inch manuals are provided below:

1/4-page image	3 3/8 inch (20 picas) x 4 1/4 inch (26 picas)
1/2-page image	7 inch (42 picas) x 4 1/4 inch (26 picas)
Full page image	7 inch (42 picas) x 9 inch (54 picas)

D.4.1.3.4 Letter size. For page-based TMs, the typeface size for text, dimensions and callouts on illustrations, including schematics and diagrams, shall be a minimum of 8 points and a maximum of 14 points, when printed. For page-based TMs, the scale of text on illustrations shall provide for a minimum final letter size, when printed, of 8 points (refer to [B.5.4.2](#)). For frame-based TMs, refer to NAVAIRINST 4120.11.

MIL-STD-3001-1A(AS) w/CHANGE 1

APPENDIX D

D.4.1.3.5 Electrostatic discharge (ESD) sensitive acronym. Mark figures and schematics with the ESD acronym.

D.4.2 Elements of illustrations.

D.4.2.1 Border rules and boxes. When necessary for clarity, border or bracket rules and boxes should be used to separate multiview illustrations on the same page or for locator/detail views (refer to [D.4.2.3.2](#), [D.5.1.3](#), [D-5.1.5](#), and see [figure D-2](#)). For IETMs, border rules and boxes do not apply.

D.4.2.2 Use of the human figure. When it is necessary to illustrate an operation, procedure, or installation, illustrations may include a human figure or parts of the body. The illustrated human figure shall not obscure necessary details of the item(s) being illustrated.

D.4.2.3 Use of locator and detail views. Locator and detail views are used in many of the types of illustrations described in [D.5.1](#) through [D.5.1.10.7](#) to clarify or simplify a complex or busy illustration.

D.4.2.3.1 Locator views. When required by the complexity of the equipment or to assist in user orientation of part(s), illustrations should contain a locator view. The overall equipment or item is shown with the area covered by the view highlighted. The locator view may be placed anywhere on the illustration that will enhance the clarity (see [figure D-2](#)).

D.4.2.3.2 Detail views. A detail view of a part or subassembly should be illustrated when the subject matter cannot be clearly illustrated in the main view. The desired subject matter may be identified with detail letter(s) or detail letter(s) adjacent to index number(s) on the main view and illustrated, as required, in the detail (see [figure D-2](#)). Complex illustrations may reference sub-detail views from a detail view, and sub-detail views may reference a sub-sub-detail view. Detail views shall be boxed or bracketed. For IETMs, detail views should be linked to the main view. Methods other than letters may be used to identify details on main views such as a link icon.

a. Sub-detail views, if necessary, may be identified with the assigned detail view capital letter prefix followed by a consecutive Arabic numeral beginning with the number 1 (e.g., A1, A2, etc.).

b. Sub-sub-detail views, if necessary, may be identified with the assigned sub-detail view's identification alphanumeric number, followed by a consecutive capital letter (e.g., A1A, A2A, etc.).

c. Sub-detail and sub-sub-detail views may also be identified by placing the item/part index number in a detail bubble (see [figure D-2](#)).

D.4.2.4 Credit lines.

a. The photographer's or illustrator's name shall not appear on any illustration.

b. A manufacturer's name, symbol, or trademark shall not appear on illustrations for the purpose of identifying the illustration.

MIL-STD-3001-1A(AS) w/CHANGE 1

APPENDIX D

c. If a preparing activity identifies an illustration with an identifying control number for retrieval purposes, the number shall be placed in the lower right-hand corner of the illustration. The number shall be no larger than 8-point type.

d. If a contractor's engineering drawing is included in the manual, the title block information usually located in the lower right-hand corner of the drawing shall be removed prior to use in the manual.

D.4.2.5 Callouts. Index numbers, reference designators, and nomenclature are used as callouts on illustrations to identify equipment, components, and significant features. Leader lines, sweep arrows and legends are used, in combination with the callouts to enhance the illustration.

a. Use leader lines or sweep arrows to help the readers orient themselves with respect to the illustration and to provide directional movement in tasks.

b. Callouts are prepared by a mechanical or electronic method, rather than by freehand lettering. (Callouts on engineering drawings prepared in accordance with [D.5.1.2](#) are acceptable.)

c. Callouts and their leader lines shall be easily distinguishable from components and other lines of the illustration.

d. Callout leader lines or arrows shall be straight lines where possible. Leader lines shall not cross each other. Callouts shall not touch the illustrated item.

e. When practical, all callouts should be placed outside the boundaries of the parts illustrated so that the parts are not obscured.

f. Use a type size no smaller than 8 points and no larger than 10 points.

g. When an item is first illustrated and its location has not yet been specified, a simplified general locator illustration may be used to identify the location of the equipment item within the system (see [figure D-2](#)).

D.4.2.5.1 Index number callouts. Index number callouts for each separate figure shall start with Arabic numeral 1 and continue consecutively. Index numbers continue in sequence from one sheet to another in a set of multisheet illustrations. For page-based TMs only, when a series of illustrations are used within the same informational, operational or maintenance task (e.g., theory, operator instruction, or removal procedure), index numbers shall continue from one illustration in that series to the next; however, if an item that already has been assigned an index number is used in more than one illustration in that series, it must retain the same index number.

a. Index numbers should be in clockwise sequence, disassembly sequence, or in order of mention in the text. To improve clarity in page-based TMs, all three index number sequence methods may be used; however, the sequence method within individual WPs shall remain consistent.

b. For maintenance with IPB data, index numbers assigned to the parts list shall be used on illustrations that support the maintenance procedures. Nomenclature callouts may be added to the

MIL-STD-3001-1A(AS) w/CHANGE 1

APPENDIX D

same illustrations to supplement the parts list index numbers when additional identification is required to support the maintenance procedure text.

c. Identify all items shown as exploded. Items drawn in phantom need not be identified (see [figure D-2](#)).

d. Index numbers should not be contained within circles unless required for a specific reason in MIL-STD-3001-1 through MIL-STD-3001-8.

D.4.2.5.2 Nomenclature callouts. Nomenclature of more than one line should have the left margin justified when placed on the illustration. All lines of copy should parallel the horizontal edges of the figure, whenever possible (see [figure D-2](#)).

a. Use upper case lettering for nomenclature callouts.

b. Nomenclature may appear on illustrations only if it can be done without crowding or reducing type size so as to make reading difficult. (Use diagram callouts of no smaller than 8 points.) The above nomenclature requirements do not apply in the development of an IETM.

D.4.2.5.3 Reference designator callouts. Reference designator callouts are a combination of letters and numbers that identify equipment and components shown on illustrations and diagrams. Reference designators may be used alone to identify an item or may be used in combination with an index number callout (e.g., 3 (CR4)). For IETMs, when reference designations are used, they should be linked to their applicable parts data.

D.4.2.6 Legends. When callout numbers are used (with the exception of IPB GAPL maintenance illustrations), a legend consisting of a numerical listing and associated identifying nomenclature may be included on the illustration.

a. For page-based TMs, legends shall always be a part of the illustration and not part of the textual information. Nomenclature used on legends and associated text shall be identical.

b. Legends are acceptable on maintenance IPB GAPL illustrations only when the illustration contains reference designations for electronic components. The legend shall consist of an alphanumeric listing of the reference designations and their associated index numbers. For IETMs, legends should not be used. All callouts (index numbers and reference designations) should be linked to the applicable parts data.

D.4.2.7 Leader lines and arrowheads. Leader lines shall not touch the callout. Arrowheads should touch the object to which the leader line applies. Arrowheads shall not enter the object to which they apply. If it is necessary to enter the object to provide for greater clarity, a breakoff symbol (—↵) should be used in lieu of an arrowhead.

a. Lines are to be uniform, short, and as straight as possible; avoid the use of dogleg-shaped lines unless absolutely necessary.

b. Leader lines should be placed at an angle.

MIL-STD-3001-1A(AS) w/CHANGE 1

APPENDIX D

- c. Arrowheads shall be used. A leader line may be highlighted if it will be easier to follow.
- d. Arrowheads should be uniform in shape and size when multiple arrowheads are used on a page.
- e. Lines and arrowheads shall not cross or come in contact with other callout lines or arrowheads, nor shall they obscure essential details.

D.4.2.8 Sweep arrows. Sweep arrows are used to help the users of the illustration orient themselves with respect to detail and locator views that appear on an illustration. Sweep arrows are also used to provide directional movement in the performance of a maintenance or operational task.

D.4.2.9 Color in illustrations.

D.4.2.9.1 Page-based TMs. Black and shades of black (one color) are normally used for TMs. Prior approval for use of color must be obtained from the requiring activity. The requiring activity will provide written approval, designating color(s) to be used.

- a. When color (other than black) is required, it should be held to the minimum absolutely necessary to highlight or clarify important information.
- b. The number of colors should be kept to a minimum by use of various techniques such as tints, patterns, cross-hatching, and dots.
- c. Any number of shades of a primary color used can be considered as one color (e.g., a two-color printing could consist of black and three shades of red).
- d. When color is approved/specified, the primary colors of red and blue should be used first.
- e. Yellow should not be used alone.

D.4.2.9.2 Frame-based TMs. Color may be used when it will enhance the understanding of the data. The use of some colors may not be appropriate for certain environmental conditions. The following color limitations shall apply:

- a. For IETMs that may be displayed on a monochrome system, reverse video and/or underlining shall be used for hotspots rather than color.
- b. The use and choice of colors will be as specified by the requiring activity.

D.5 DETAILED REQUIREMENTS

D.5.1 Types of illustrations.

D.5.1.1 Photographs. Photographs may be used for illustrations. When a photograph provides for better clarity than a line drawing, the photograph should be used. Photographs shall not be used on foldouts.

MIL-STD-3001-1A(AS) w/CHANGE 1

APPENDIX D

a. Line tracings of photographs are also acceptable. When a line tracing is prepared, proper definition of line work should be used in lieu of photo retouching. The intended subject matter should be highlighted and unnecessary background should be eliminated. Items required for reference (location) should be subdued.

b. If halftones are used, they should be detailed and sharp, free of heavy shadows, distorted objects, cluttered foregrounds or backgrounds, and should give good contrast from white, middle tones, and black.

c. Retouching may be used to emphasize detail, exclude unwanted detail, correct slight photographic defects and eliminate undesirable shadow. Tonal values shall be maintained.

d. If the intention is to use photographs in lieu of line art, it is preferred that a digital camera be used to produce the required photos. This will negate the use of halftones and the need for retouching and screening. However, if the final reproducible copy is intended to produce paper output, it may be better to prepare line art in lieu of photographs. Obtain approval from the requiring activity for the use of photographs in paper TMs.

D.5.1.1.1 Prescreened photographs. Although not preferred, prescreened photographs are acceptable as direct image copy provided they are screened only once. The screen of the final sized illustration will be specified by the requiring activity. When prescreened photographs are used, they should be clearly marked to indicate prescreening. Unscreened continuous tone photographs and/or original illustrations must be supplied with final reproducible copy.

D.5.1.1.2 Engineering drawings. Unless specified otherwise by the requiring activity, engineering drawings shall not be used as illustrations. When used, the drawings shall meet the following criteria:

a. a. Engineering drawings shall be in accordance with ASME Y14.100, ASME Y14.24, ASME Y14.34, ASME Y14.35M, and MIL-STD-31000 (required for new designs after 01 July 1990). Engineering drawings shall be modified, as necessary, to meet the content, style, arrangement, legibility, format, and production requirements described in this document and the contract.

b. All unnecessary data that would reduce the comprehension or clarity of the drawing shall be removed. Data includes borders, title blocks, manufacturer's notes, and other irrelevant material. Manufacturer's wiring diagram drawing numbers may be retained for the preparation of aircraft wiring diagram manuals if the drawing numbers are used to develop an easy to use WP numbering concept. Grid locations, if provided, should not be removed.

c. They must be reduced or redrawn to meet TM page or frame size restrictions.

D.5.1.1.3 Multiview illustrations (page-based TMs only). Multiple view illustrations shall be provided when necessary to identify significant features on an illustration, improve identification of parts or clarify the relationship or the location of the parts. Each view shall be oriented and enlarged as necessary to identify significant features (see [figure D-2](#)).

MIL-STD-3001-1A(AS) w/CHANGE 1

APPENDIX D

a. Each view may be identified by a detail capital letter in block size print in a bubble or a caption. Orientation shall be by the use of directional arrows or text (e.g., "Rotated 180 degrees") as it relates to the main illustration.

b. Views may or may not be captioned, but if one view is captioned, all shall be captioned. The caption shall be centered with respect to the view to which it applies. Where captions are not used, the identifying letter shall be so centered. When a caption and an identifying letter are used together, the identifying letter shall precede the caption. Identifying letters and captions shall be larger and bolder than any other lettering in the illustration. The identifying letter shall be larger than the caption when both are used.

D.5.1.4 Foldout and multisheet illustrations (page-based TMs only). When an illustration, including diagrams, must be larger than a single TM page for clarity or to be easily viewed by the TM user, foldout presentation should be used. Foldouts shall be placed at the end of the applicable WP and not at the rear of the TM. Foldout-foldup illustrations shall not be used. When approved by the requiring activity, foldouts may be placed at the rear of the applicable WP or at the rear of the TM for intermediate and depot level manuals.

a. A one-page apron is required for each printed foldout. The planning of a foldout illustration shall include consideration of its usability relative to the length of each data increment.

b. A foldout illustration page shall not exceed 45 inches in width (including the apron) and 11 inches in height. The image area of a foldout illustration page shall not exceed 36 inches in width by 10 inches in height including the marginal copy.

c. Foldout illustrations shall be printed as right-hand pages and shall be backed by blank pages. Individual illustrations in groups of related illustrations capable of being presented on a single page shall not be grouped together as a foldout.

D.5.1.5 Exploded view illustrations. An exploded view (see [figure D-3](#)) is an illustration that shows a unit separated or disassembled but with all the parts positioned in correct relationship to each other. Exploded views are used to support the IPB GAPL and additional maintenance procedures in the maintenance WPs. The following guidelines are recommended to ensure clarity of presentation:

a. Index numbers, keyed to a GAPL, legend, list, or text reference, can be used to identify parts.

b. No more than 20 items should be called out in a 7 inch x 10 inch area if nomenclature is used.

c. Whenever possible, the average maximum number of callouts within a 7 inch x 10 inch area should be 70. All callouts (numerals) should be outside the boundaries of the parts being illustrated.

d. There should not be more than five callouts (numerals) in any 1 square inch area.

MIL-STD-3001-1A(AS) w/CHANGE 1

APPENDIX D

- e. If the criteria of subparagraphs [c.](#) and [d.](#) above cannot be met, use detail views of the figure.
- f. When necessary, provide a locator view (refer to [D.4.2.3.1](#)) to show the orientation of the view with respect to its next higher assembly (NHA) and also if the illustrated item is part of a larger unit. A locator view showing the location of a weapons replaceable assembly (WRA) in an aircraft shall not be provided at the depot level of maintenance. A locator view showing the location of a WRA in an aircraft may be provided at the intermediate level of maintenance when the intermediate level maintenance procedure is contained in an aircraft maintenance manual containing both organizational and intermediate maintenance procedures.
- g. For maintenance IPB GAPL exploded views, index numbers shall be assigned in disassembly sequence. Nomenclature callouts may be added to further clarify or identify maintenance instructions on maintenance IPB GAPL exploded views.
- h. For all other exploded view illustrations, index numbers shall be assigned in a clockwise order beginning with the number 1.
- i. Limit the level of detail to that required to positively identify parts. Excessive detail makes the illustration complex and does not contribute to usability.
- j. Use broken lines for parts shown merely for reference, but not called out. Ensure that the broken lines are legible.
- k. Center (axis) lines should be used on exploded views to show parts relationship.

D.5.1.6 Cartoons. Cartoon-type drawings shall not be used.

D.5.1.7 Pictorial illustrations. This class of illustration includes end item familiarization views, locator illustrations and assembly and installation illustrations which depict physical items (see [figure D-4](#)). It does not include exploded views. These drawings must attempt to show the "how to" instructions defined in the text. Their purpose is to present a direct duplication of what will be seen on the actual hardware. Some of the recommended guidelines for preparing pictorial illustrations are:

- a. Orient the illustration so that the view represented is identical to the view the technician sees when performing the maintenance task. If the item is illustrated as installed in the end item, indicate the exact orientation of the view by using a locator view and directional arrows. For example, for a view of an item installed in an aircraft, use a locator view showing its location relative to the aircraft, and directional arrows showing which way is forward, aft, inboard, or outboard (unless the orientation is obvious). When necessary to portray position or relative location, other equipment items may be shown in phantom.
- b. An alternate method, applicable to aircraft, is to provide aircraft reference numbers, such as the numbers for fuselage station, wing station, butt line and waterline. With this method, at least two of each type of reference line would be shown, so that the technician would be able to determine the orientation of the view.

MIL-STD-3001-1A(AS) w/CHANGE 1

APPENDIX D

c. On mechanical equipment illustrations, use no more than 20 callouts in a 7 inch x 9 inch area when nomenclature is used as callouts. There may be as many as 70 callout numbers in a 7 inch x 9 inch area, provided they are all outside the boundary of the item illustrated. If placing some callouts inside the boundary is unavoidable, use no more than 40 callouts.

d. On electronic circuit cards, use no more than 70 callouts. Use the maximum amount only when:

- (1) all callout numbers are outside the boundaries of the circuit card,
- (2) there are no more than five callouts in any square inch area,
- (3) the callout numbers are in rows and columns.

e. When determined physically feasible, assign callout numbers clockwise in sequence, beginning in the upper left of the drawing. When an illustration is used for both IPB and maintenance information, it shall be indexed in disassembly order.

f. Use straight (not doglegged) arrowheaded leader lines. In extremely rare cases, doglegged lines will be necessary due to the type of artwork. Leader lines shall never cross each other.

g. For callouts or other verbal material on illustrations, use all upper case, 8-point or larger font.

h. When drawing an illustration, use the heaviest lines for the outlines of the parts being illustrated. Use medium lines for the leader lines, axis lines, and details that are necessary to identify parts.

D.5.1.8 Combination illustrations. Combining photographs or continuous tone artwork with line drawings is not recommended.

D.5.1.9 Charts and graphs as illustrations.

a. Information that would be most usable as a chart or graph should be so presented.

b. Charts and graphs are prepared as illustrations. Instructions shall be provided for use and interpretation of complex graphs.

D.5.1.9.1 Line graphs.

a. Clutter. The number of ideas conveyed per graph should be minimized. Line graphs should depict a maximum of four relationships between the axis variables. Lines depicting relationships are to be coded to distinguish one from another.

b. Orientation of axes. If there is a natural orientation for the axes (e.g., altitude on the vertical axis), the axes are to be so oriented.

MIL-STD-3001-1A(AS) w/CHANGE 1

APPENDIX D

c. Grid lines. The number of grid lines used are such that the user can read values to the required degree of accuracy. Size of the illustration is such that the grid lines should be no less than 0.1 inch apart. Grid lines are lighter than the graph lines and should not obscure detail necessary for proper use of the graph.

d. Graph scales. Graph scales are linear or nonlinear as required for proper comprehension and use. The axes shall be labeled to indicate the variables and units of measurement.

D.5.1.10 Diagrams.

D.5.1.10.1 General preparation requirements. The subsequent paragraphs describe the general preparation requirements for the various types of diagrams that may be required to support the operation and maintenance data contained in the TM. The following types of diagrams may be included in the TM:

- a. Block diagrams.
- b. Schematic diagrams.
- c. Pictorial diagrams.
- d. Cutaway diagrams.
- e. Troubleshooting logic diagrams.
- f. Wiring diagrams/wire lists.
- g. Cable diagrams.
- h. Piping diagrams.
- i. Test setup diagrams.

D.5.1.10.2 Specification requirements. Diagrams shall be prepared in accordance with the specifications listed below:

<u>Subject</u>	<u>Equipment Covered</u>	<u>Specification</u>
Abbreviations	All	COMNAVAIRFORINST 4790.2
Engineering Drawing Practices	All	ASME Y14.24, ASME Y14.34 ASME Y14.35M, ASME Y14.100 and MIL-STD-31000,
Graphic Symbols	Electrical and Electronic Mechanical	IEEE 315 SUPP, IEEE 280 ASTM F856 and NAVSEA drawing 803-5001049
	Digital (Logic)	IEEE 91A/91
Reference Designators	Electrical and Electronic	ASME Y14.44
Unit Symbols	All	IEEE STD 260.1
Logic	All	IEEE 91A/91
Dimensions and Tolerances	All	ASME Y14.5

D.5.1.10.3 General methods. The specifications listed in paragraph [D.5.1.10.2](#) shall be followed for general methods in acquiring diagrams. Other requirements are as follows:

MIL-STD-3001-1A(AS) w/CHANGE 1

APPENDIX D

a. Layout. The layout of all illustrations and diagrams shall remain easily readable and compatible with the intended use. The layout of the illustrations and diagrams shall enhance and support the maintenance text to which they apply.

(1) All electrical/electronic and fluid flow diagrams shall conform to circuit or system flow without regard to physical arrangement of components and parts and their relative location in the system. The flow should read from left to right and top to bottom. Ideally arranged diagrams, including multi-frame drawings, should show the primary inputs in the upper left corner and should flow across and down the page/frame to end with the primary outputs in the lower right-hand corner of the diagram.

(2) Diagrams shall consist of symbols grouped as circuit entities (e.g., amplifiers and power supplies). Each group shall be located on the diagram so that the complete diagram requires a minimum amount of wiring (electrical/electronic diagrams) or the shortest lines (fluid or mechanical). All wires/lines should be routed as directly as possible so that they cross the fewest wires/lines as possible.

b. Consistency. A standard referencing system for associated text, signal flow, and other diagrams should be used.

(1) Standard graphic symbols should be used when possible.

(2) If special graphic symbols are required, they should be made visually distinctive from other graphic symbols used and included in a special symbols chart.

(3) Official nomenclature is used for hardware, controls, indicators, switches, etc.; consistent, standard nomenclature is used for functions, signals, etc.

c. Appropriate detail. All information required to fulfill the intended purpose of the diagram should be used; overcrowding must be avoided.

(1) Complete detail should be provided for hardware, function, signal identification, measurement data (voltages and waveforms), explanatory text, connectors, terminal boards, pin numbers, signal names, reference designators, component values and tolerances, replacement components, etc.

(2) All inputs and outputs should be clearly labeled. In single-page/frame diagrams, termination points shall be shown for every relevant wire, pipe, etc. In multi-page/frame diagrams, unterminated line segments shall be identified by appropriate symbols with references maintaining continuity from page to page. For IETMs, links shall be used to provide continuity.

(3) To the extent possible, and to keep diagram format consistent for readability, place inputs and associated labels near the diagram left or top edge and outputs and associated labels near the diagram right or bottom edge. The continued portions of multi-sheet diagrams and schematics should align, or should be labeled or linked.

MIL-STD-3001-1A(AS) w/CHANGE 1

APPENDIX D

(4) For locating information, relevant components shall be identified on the diagram or referenced or linked to an explanatory listing. Where applicable, the wording on the diagram should correspond exactly with the wording in the text.

d. Inappropriate data. Data not related to the purpose of the diagram shall not be included. Pertinent detail of nonrepairable and nonreplaceable components shall be held to a minimum.

D.5.1.10.4 Signal flow. Signal flow, especially for electrical and electronic equipment, critically affects the understandability of diagrams. To assist the TM user in following the diagram, where possible, major signal or pressure flow should be from left to right, and feedback or return flow should be from right to left. For IETMs, signal flow may be indicated using animation or color. As applicable, the methods for portraying signal flow outlined in [D.5.1.10.4.1.1](#) through [D.5.1.10.4.1.3](#) should be used. For IETMs, signal flow for specific circuitry or for a single circuit may be displayed separate from the entire diagram by providing links on the diagram. When the link is activated, only the flow for the specific circuitry or for the single circuit shall be displayed. This may negate the need to use some of the methods discussed below.

D.5.1.10.4.1 Signal connections. Signal connections can be portrayed in one of three methods:

a. Point-to-point method. Shows each signal separately with a continuous line to represent its flow (see [figure D-5](#)).

b. Highway method. Blends two or more signals together in a single line (see [figure D-5](#)). This method is useful in showing the flow of a group of related signals. Any number of signals may be blended together. Any signal that has been blended into the main line is blended out at some other point on the line. Once a signal has been blended out of a line, it can no longer be present on that line. Each signal blended in or blended out of the line shall be identified.

c. Interrupted flow method. Use special symbols to interrupt signal flow. This method may be used within a single sheet/frame of a diagram, between sheets/frames of a diagram, or between diagrams. Refer to paragraphs [D.5.1.10.4.1.1](#) through [D.5.1.10.4.1.3](#) for types of special symbols and techniques used to interrupt signal flow. The method used to show interrupted signal flow shall be consistent on all diagrams in a TM.

D.5.1.10.4.1.1 Techniques within a single sheet of a diagram. Interrupted flow within a single sheet/frame diagram is depicted using one of the following techniques:

a. Oval connector. Used to continue signals from one area of a sheet to another area.

(1) Any number of signals may be bracketed together.

(2) Each signal shall be identified at its source bracket and destination bracket.

(3) Oval connectors shall have a unique letter identifier inside the oval (see [figure D-6](#)).

(4) The position of the source and destination connectors can be identified by zone numbers (refer to [D.5.1.10.4.1.2 c.](#))

MIL-STD-3001-1A(AS) w/CHANGE 1

APPENDIX D

b. Signal returns. Used to continue signal returns within a single sheet of a diagram.

(1) Returns have a unique number identifier inside the network.

(2) Each return is labeled the first time it appears on the diagram (preferably on the left edge of the diagram) (see [figure D-7](#)).

c. Breakoff symbols. Only power forms, clock pulses, and other multiuse, minor signals use the breakoff symbol technique.

(1) Each signal is identified adjacent to its breakoff symbols.

(2) The source of signals is shown at the left edge of the diagram (see [figure D-7](#)).

(3) For IETMs, if this method is used, the origin and destination of the signal should be linked.

D.5.1.10.4.1.2 Techniques between sheets of a diagram. Interrupted flow between sheets of a diagram should be depicted using one of the following techniques:

a. Boat symbol. Used to continue signals from the right edge of one sheet to the left edge of the following sheet within a multisheet diagram (adjacent sheets of a diagram only).

(1) Used for single signals only.

(2) Boat symbols shall have a unique letter inside the boat (see [figure D-8](#)).

b. Numerical or letter identifier. Used to continue signals between sheets of a diagram. See [figure D-8](#) for an example of numerical identifiers. A unique letter identifier may also be used in lieu of numbers.

c. Oval connector. Used to continue signals from one area of a diagram to another. Application is the same as within a single sheet of a diagram (see [figure D-6](#)). For identification of source and destination areas, the following zoning requirements are recommended used for multisheet diagrams:

(1) Vertical zones shall be numbered; horizontal zones shall be lettered.

(2) The number of horizontal zones shall be limited to 10.

(3) Zones shall always be numbered as below, even if all zones are not used on any sheet:

Sheet 1	Starts with Zone 1
Sheet 2	Starts with Zone 11
Sheet 3	Starts with Zone 21, etc.

MIL-STD-3001-1A(AS) w/CHANGE 1

APPENDIX D

NOTE

For IETMs, zoning does not apply. The origin and destination of the signal should be linked.

D.5.1.10.4.1.3 Techniques between diagrams. Interrupted flow between diagrams is depicted using one of the following techniques:

- a. Oval connectors. Source and destination figure numbers are inserted before zone references (see [figure D-6](#)).
- b. Pyramid diagram. Diagram number is included from one diagram to another (e.g., include reference to 1 on diagram 2 and reference to 2 on diagram 1) (see [figure D-8](#)).

NOTE

For IETMs, zoning does not apply. The origin and destination of the signal should be linked.

D.5.1.10.4.2 Signal difference. Various techniques are available to indicate signal flow, signal importance, and type, such as the following (see [figure D-9](#)):

- a. Use wide lines to represent major signals.
- b. Use special arrowheads to indicate signal types.
- c. For page-based TMs, use different colors if approved by the acquiring activity (refer to [D.4.2.9](#)).
- d. For IETMs, animation or color may be used.

D.5.1.10.4.3 Signal junctions. The relative importance of signals may also be indicated by the way signal junctions are represented. Subordinate junctions are used to indicate differences in signal importance. Coordinate junctions are used to indicate equality in signal importance (see [figure D-10](#)).

D.5.1.10.5 Schematic and functional flow diagrams. Electrical schematic diagrams shall be prepared in accordance with IEEE 315 (see [figures D-11](#), [D-12](#), and [D-13](#)). Electrical and electronic schematics and fluid and mechanical schematics shall conform to circuit or system flow without regard to physical arrangement of components and parts and their relative locations. The flow shall read from left to right and from top to bottom. Diagrams, to the extent possible, shall show the primary inputs in the upper left corner and shall flow across and down the illustration to end with the primary outputs in the lower right corner of the diagram. When diagrams are specifically prepared for maintenance purposes, as much of the following information as applicable shall be included. Any additional information that is available and that will not disrupt the flow or understanding of the diagram shall be included in the illustration:

- a. Use standard symbology and representation when depicting electronic circuitry. That is, whenever a standard circuit, such as a Darlington amplifier or a logic gate is used in a schematic,

MIL-STD-3001-1A(AS) w/CHANGE 1

APPENDIX D

it should be recognizable. Ideally, all the components that perform one function, such as an amplifier, should be drawn in the same area of an illustration.

b. Dividing a small circuit on two pages/frames of an illustration is to be avoided. This should increase the technician's ability to recognize the circuit and should reduce the need for detail in the principles of operation.

c. An illustration should limit the number of components in any 2-inch square area. This limit should not exceed 12 components. For example, [figure D-14](#) displays two selected 2-inch square areas encompassing only six and seven components in a fairly crowded situation. The total number of components displayed in any full page/frame schematic or foldout should not exceed 80 components on any page/frame.

d. Each component in the schematic must be identified. The labeling should be brief but contain sufficient information to assure proper understanding and maintenance performance. For IETMs, components shown on the schematic should be linked to the applicable parts information data.

e. For callouts, component designations, and other textual material on schematics, use all upper case 8-point type or larger.

f. Briefly explain any nonstandard or uncommon symbols in a legend on each figure where they are used. Place the legend and any additional notes in the lower left portion of the diagram. A detailed explanation of nonstandard or uncommon symbols should be fully defined in the TM introduction. For IETMs, the legend should be linked from where the symbols are used on the diagram.

g. There should be no more than 15 intersections in any 2-inch square area. This includes all line intersections, whether an electrical connection is made or not. [Figure D-14](#) is an example of a schematic with few intersecting lines.

h. Clearly label all inputs and outputs. Inputs shall be at the left of an illustration and outputs at the right.

i. Clearly label DC resistance of windings and coils (if more than 1 ohm).

j. Include or link an illustration of CRT display next to the point at which it will be observed, usually at a designated test point (TP).

k. Show wiring requirements for critical grounding points, shielding, pairing, etc.

l. Include power or voltage ratings of parts.

m. Include indication of operational controls or circuit functions.

n. Show warning notations for electrical hazards at maintenance points.

MIL-STD-3001-1A(AS) w/CHANGE 1

APPENDIX D

- o. Specify circuit voltage values at significant points (tube pins, test points, terminal boards, etc).
- p. Specify significant circuit resistance values at designated reference points (information may be in tabular form).
- q. For page-based TMs, include zones (grid system) on complex schematics. When technical data is prepared from engineering drawings, zone reference may be the same.
- r. For page-based TMs, include circuit element zone locations (on complex schematics) in tabular form on the drawing or associated document when such location of information will facilitate use of the schematic.
- s. Signal flow direction in main signal paths shall be emphasized.
- t. Device ratings shall be located close to the device symbol to assure correct identification. Polarity markers shall be shown on all instrument transformers and capacitors.
- u. Piece part details are shown only when replacement is authorized at the maintenance level covered or when understanding is required for fault isolation.
- v. For non-repairable assemblies, all inputs and outputs are shown with enough detail to understand how inputs relate to outputs (complete details for simple circuits and symbols for complex circuits).

D.5.1.10.5.1 Circuit parameters. Circuit parameters should be marked according to their reference designations (if applicable), types, and values. When these markings tend to clutter the field of the illustration, a table of these markings, in order of reference designation (electrical or electronic diagrams) or nomenclature (fluid or mechanical diagrams) should be included, or tabular data referenced, for all circuit parameters. For IETMs, this circuit parameter data should be linked. Reference designations should agree with those used in related engineering drawings. Nomenclature should be in accordance with [B.5.4.7.8](#). Normal operating conditions and other conditions specified by the applicable technical content standards should be indicated.

D.5.1.10.5.2 Test point identification symbols. Identification of test points by symbols shall not be employed where the test points are readily identifiable by other means. For example: "Test jacks (TP-5)," "Connector pins (J100-M)," and "Component pins (X4-2, Q1-E, and Z5-14)" are readily identifiable points and do not require symbols. Test points that are not otherwise identifiable (artificial test points) shall be identified by test point symbols. The test point symbol shall be an encircled upper case letter and an Arabic numeral. These test points shall be referred to in the text such as "Test point A2."

D.5.1.10.5.3 Use of artificial test points. Artificial test points shall be used when specific voltage and resistance test points, used in checking a circuit, are otherwise unidentifiable. Different letters shall be assigned to each component (on a diagram) (e.g., test points A1, A2 and A3 in component 1, test points B1, B2 and B3 in component 2). All test points shall be identified on the diagram by their assigned identifying code.

MIL-STD-3001-1A(AS) w/CHANGE 1

APPENDIX D

D.5.1.10.5.4 Components shown on schematic diagrams. When it is necessary to show components of a system on a schematic diagram, the general shape of the component and a minimum amount of detail shall be illustrated. For IETMs, the illustration may be linked. This requirement applies to those components that will be easily recognized by the reader and, therefore, would assist him in interpreting the diagram. It does not apply to components without definitive shapes or recognizable detail. For example, if an electronic component is located in a container that is essentially a box without dials or switches, an outline of a "box" will suffice. The nomenclature of the component shown shall appear adjacent to the item (see [figure D-15](#)).

D.5.1.10.6 Functional diagrams. Functional block diagrams are designed to provide a simplified description of particular operation or maintenance actions. The functional blocks are logically or sequentially arranged to describe the action taking place and show all input and output signals. Variations of the block diagram approach can be used to describe principles of operation, troubleshooting and maintenance efforts. Most principles of operation are described in text form with supporting functional block diagrams as shown in [figure D-16](#). The following general guidance is provided concerning the preparation of block diagrams:

- a. Abide by the basic schematic requirements that apply equally as well to functional flow diagrams.
- b. Functional block diagrams show the complete system or subsystem on one sheet (if possible) (see [figure D-16](#)). Methods to be used include functionalizing components, grouping subfunctions into functions, or continuing until the complete system or subsystem can be shown on one sheet or frame. (For page-based TMs, a foldout may be used when approved by the acquiring activity; refer to [D.5.1.4](#)).
- c. Functional diagrams shall provide enough details to relate the input to output signals by using arrowheads to indicate signal flow direction when necessary and specifying signal characteristics and tolerances in pictorial or tabular form. Indicate direction flow by arrows. Signal flow (electric/electronic) or fluid/pneumatic flow shall be from left to right. For IETMs, signal flow may be depicted using animation or color.
- d. Functional diagrams shall account for all maintenance significant components by ensuring the user can relate the schematic diagram to the functional diagram, blocking the components on the schematic to correspond with blocks on the functional, or providing a table relating components to functional blocks.
- e. Functional diagrams shall show hardware boundaries by using solid, dashed, or dotted lines; various line weights; or different colors or shades (when approved by the requiring activity).
- f. Always give full consideration to the presentation method.
- g. Avoid reverse directional flow except for feedback. Feedback flow shall be from right to left. For IETMs, flow may be depicted using animation or color.

MIL-STD-3001-1A(AS) w/CHANGE 1

APPENDIX D

- h. Label all inputs and outputs of each block on the diagram. The label can consist of the name of the input or output, a waveform or symbol in the flow line itself.
- i. Identify all test points clearly and distinctly. When required, place all waveforms in close proximity to the appropriate test point, or link the waveform data from the test point. If impractical, provide a good reference to its location.
- j. Define any nonstandard or uncommon symbols in a legend on each diagram on which they appear. Place the legend and any required notes in the lower left portion of the diagram. For IETMs, the legend data should be linked.
- k. Uncommon symbols and their definition shall be numbered in numerical sequence.

D.5.1.10.7 Cutaway diagrams. Cutaway diagrams (see [figure D-17](#)) employ pictorial symbols of components drawn with interconnecting lines. Diagrams of this type provide a simplified method of showing piping between components with the general piping arrangement emphasized. Complete principles of operation of the flow path are difficult to explain as only the external features of the components are shown. Internal flow within a component is not shown, thereby not fully describing the flow of the liquid or gas. Arrowheads are used to show direction of mechanical action or fluid flow. For IETMs, direction of mechanical action or fluid flow may be depicted using animation or color.

D.5.1.10.8 Combination diagrams. The combination diagram utilizes the best features of the graphic, pictorial and cutaway diagrams and symbols in the same drawing with integral interconnecting lines. Diagrams of this type are best for illustrating principles of operation because they emphasize piping, function and flow paths for each component and best describe the flow path of the fluid or gas (see [figure D-17](#)).

D.5.1.10.9 Logic diagrams.

- a. Logic diagrams (see [figure D-18](#)) are used to show digital circuitry operation. Graphic symbols from IEEE STD 91 are used. If the logic circuit has no specified symbol, it can be identified with a rectangle that is labeled to show all circuit functions.
- b. Power and clock connections are identified in a truth table or are connected using breakoff signals.
- c. When necessary for clarity, a truth table or timing diagram should be prepared or should be referenced or linked from another diagram. For logic functions, the truth table timing diagram may be shown inside a block to describe the relation of input to output signals. (Whenever possible, truth tables should be placed in the text area, or linked, and not on the figure.) (See [figures D-19](#) and [D-20](#).)

D.5.1.10.10 Simplified diagrams. Simplified diagrams include key components for explanatory purposes and omit selected components or groups of components, or details for clarity. Simplified circuitry and/or simplified functional divisions indicate excluded or included

MIL-STD-3001-1A(AS) w/CHANGE 1

APPENDIX D

components in the diagram title (e.g., "Figure 3. Simplified R-T Control Circuit with Cockpit Control Switch in Off Position (All Relays Unoperated.)"). (See [figure D-21](#).)

D.5.1.10.11 Partial diagrams. Partial diagrams are used to show all circuit details completely and reference all destinations of input or output connections (see [figure D-22](#)).

D.5.1.10.12 Test diagrams. There are two types of diagrams used to support test procedures. Test diagrams (see [figure D-23](#)) are used to show test stimuli, item (or circuitry) under test, and test measurement components. Test setup diagrams (see [figure D-24](#)) are used to show the interconnection between the test equipment and the unit (s) under test. The setup diagram may be presented schematically or pictorially.

a. When diagrams exist for the item under test, a block diagram representation may be used.

b. In TMs containing testing data, the item under test shall be emphasized (shown in detail); in test equipment maintenance TMs, the test equipment shall be emphasized.

D.5.1.10.13 Power distribution diagrams. Power distribution diagrams depict components involved in power input, power form generation, and power distribution. They are grouped by power flow (see [figure D-25](#)).

D.5.1.10.14 Pyramid diagrams.

a. Pyramid diagrams are a set of interrelated diagrams consisting of:

(1) A master block diagram.

(2) Detailed block diagrams.

(3) Schematic diagrams.

b. If the equipment covered is complex, several levels of detailed block diagrams may be required (see [figure D-26](#)).

D.5.1.10.15 Wiring diagrams/illustrations. Weapon systems and equipment, engines, and support and test equipment that have wiring or cabling shall include interconnection information in one or more forms such as wiring and cabling diagrams and wire bundle access and routing illustrations. Wire lists are also considered interconnection information but are not illustrations and are covered under tabular data (refer to [B.5.4.7.15.1](#)).

D.5.1.10.15.1 Wiring diagrams. Wiring diagrams (see [figure D-27](#)) shall be structured and developed in accordance with the requirements contained in MIL-STD-3001-5. To facilitate training and consistency in presentation, the wiring requirements contained in SAE-AS50881, shall be followed whenever possible when preparing the wiring diagrams. These requirements include the standard methods for identifying wiring system circuit functions, individual wires, connectors and terminal boards, and assigning reference designations. In general, the layout of

MIL-STD-3001-1A(AS) w/CHANGE 1

APPENDIX D

wiring diagrams shall be the same as for schematic diagrams (refer to [D.5.1.10.5](#)); however, the following additional ground rules apply:

- a. Each line representing the wires and interconnections shall be coded or otherwise identified.
- b. Each wire shall be shown individually.
- c. Each wire shall be drawn so that it can be traced from point of origin to destination.
- d. Wires located within a cable harness shall be shown as a single wire. Wire bundling techniques for aircraft system wiring shall not be used.
- e. Normally, aircraft wiring diagrams are drawn and scaled for a foldout presentation. However, to facilitate on-aircraft wire chasing and troubleshooting, wiring diagrams may be drawn and scaled to a 11-inch x 8 1/2-inch landscape format and included in a normal size TM. These two formats shall not be combined in the same TM.
- f. Wire colors may be indicated by using color designation codes. Indication of color designations is preferable when many colors and color combinations such as BK-W are to be shown. Recommended single- and two-letter color designations for use specifically on diagrams are as follows:

<u>Wire Color</u>	<u>Designation</u>
Black	BK
Brown	BR
Red	R
Orange	O
Yellow	Y
Green	G
Blue	BL
Violet	V
Purple	PR
Gray	GY
Slate	S
White	W

- g. A junction of lines shall be indicated by a dot at the junction of the lines. Lines crossing each other, without a dot, indicate that they are not connected in any way.

D.5.1.10.15.1.1 Wire bundle routing illustrations. For aircraft wiring systems, illustrations shall be provided showing the routing of all aircraft bundle assemblies throughout the aircraft (see [figure D-28](#)).

D.5.1.10.16 Cable diagrams. Cable diagrams shall be included in equipment and support equipment TMs if the technician must install or remove cables when performing test procedures, installation, assembly, disassembly, modification, service, etc. (see [figure D-29](#)).

MIL-STD-3001-1A(AS) w/CHANGE 1

APPENDIX D

a. Cable diagrams provide all the information necessary to make the electrical connection between assemblies, chassis, bays, units, and systems in an easily understood format.

b. Each cable diagram should consist of an illustration and accompanying table. If cable routing is of a special nature, it shall be so noted. For very complex systems where routing is of great importance, additional diagrams showing desired cable locations may be necessary (see [figure D-29](#)). The accompanying table shall meet the following requirements:

- (1) Cable entries shall be listed in numerical order or by preferred connection sequence.
- (2) Cable origin shall precede the cable destination.
- (3) Cable origin and destination shall include assembly name, assembly jack number, and cable plug number.
- (4) Both table and illustration shall appear on the same page or facing pages. For IETMs, the table should be linked from the applicable illustration. The table is considered text and is not part of the figure.

c. Cable diagrams show all related connectors. Assembly names and jack numbers should be listed.

d. For simple equipment, a table may not be needed, and an interconnection diagram that actually shows the routing of the cables may be substituted (see [figure D-30](#)). The internal connections of the equipment or assemblies are usually omitted.

D.5.1.10.17 Piping diagrams. Weapon systems or equipment that include piping in their design are supported with information in the form of piping diagrams. The diagrams shall meet the requirements for illustrations and diagrams presented in this appendix (see [figure D-31](#)).

D.5.1.10.18 Fluid power/gas diagrams. Fluid power/gas diagrams illustrate those systems that transmit and/or control power through the use of pressurized fluid, within a closed circuit of tubing, pipes or hoses or combination thereof. ISO 1219-1 and ISO 1219-2 provide for fluid power/gas diagrams that are drawn either as graphic, pictorial, cutaway, or combination drawings. In addition to the general requirements for the preparation of schematic diagrams provided in [D.5.1.10.5](#), refer to the additional requirements provided in [D.5.1.10.18.1](#) and [D.5.1.10.18.2](#).

D.5.1.10.18.1 Arrangement of symbols. Where components have a specific mechanical, functional, or otherwise important relationship to one another, their symbols shall be so placed in the diagram to illustrate their relationship in the circuit. Where a component requires a specific mounting position, its symbol shall be so drawn and a NOTE added to point out the correct positioning. Spacing shall provide room for adjacent data without crowding.

D.5.1.10.18.2 Conductors. Interconnecting lines between various components in a diagram represent a means of conducting fluid or gas. The lines are a very important part of the system and shall be drawn very carefully. For clarity, lines should always be straight and direct. Lines are not intended to pictorially illustrate the actual piping or fittings. Horizontal and vertical lines

MIL-STD-3001-1A(AS) w/CHANGE 1

APPENDIX D

shall be used. Square corners and 90-degree intersections shall be used. Conductors may be drawn as either single or double lines dependent upon the type of diagram being used.

- a. Single lines are used in graphic diagrams.
- b. Double lines are used in cutaway diagrams.
- c. Pictorial and combination diagrams may use single or double lines or both.

D.5.1.10.18.2.1 Single lines. Conductors which convey power actuating fluid, either pressure or return, are called working lines and shall be drawn as a single unbroken line. Conductors that carry fluid that is used to actuate components are called pilot lines and shall be drawn as a series of long dashes. Sensing lines, if very short such as gage lines, shall be drawn the same as the line to which it connects. Internal seepage of components or exhaust pilot fluid is returned to the tank by drain lines. The lines are drawn as a series of short dashes. Working, pilot and drain lines shall be drawn thick line width. Sharp angles (90 degrees) shall be used when lines drawn between symbols change direction. Dashes shall join at corners. Fluid and electrical lines, unless they are interrelated, shall not be combined in one diagram. Graphic symbols for fluid power diagrams present symbols for both pneumatic and hydraulic media in the same diagram.

D.5.1.10.18.2.2 Double lines. Double lines shall be used to illustrate the conductors in cutaway diagrams. Double lines are sometimes used in pictorial diagrams to illustrate the piping arrangements more clearly. The included space between double lines can be used to show relative pipe size and may also be used to indicate functions such as working, pressure, pilot, return, drain, bleed, different fluids, etc., when crosshatching, shading, etc., are used. Double lines shall be drawn thick line width.

D.5.1.10.18.2.3 Joining lines. Single lines which join shall terminate with or without a dot. If no dot is used, then one of the two joining lines shall dead end. Dash lines shall begin and end with a dash of full length at the junction with other lines. Double lines forming a junction shall have square corners.

D.5.1.10.18.2.4 Crossing lines. Single and double lines shall cross with or without a loop. Where dash lines and solid lines cross, the solid line shall intersect the dash and not the space between the dashes.

D.5.1.10.19 Component data. Nomenclature, names, notes and values are sometimes necessary in addition to the components symbol for circuit analysis, installation or service. This component data can be either on the diagram or be identified through the use of index numbers with an accompanying legend. For IETMs, the legend data may be linked. If the nomenclature, name, note or value is placed on the diagram, it must be positioned so that it does not interfere with the piping or other features of the diagram.

D.5.1.10.20 Rotation. Direction of rotation shall be indicated by an arrow. It is understood that the arrow is on the near side of the shaft to denote direction of rotation. Arrows pointing in opposite directions for the same motor shaft indicate the shaft can rotate in either direction. The

MIL-STD-3001-1A(AS) w/CHANGE 1

APPENDIX D

text covering the component shall stipulate whether the direction of rotation is as the component is viewed from the front or the rear.

D.5.1.10.21 Direction of flow. Direction of flow in conductors shall be shown by arrowheads on single lines or by arrows within the double lines. For IETMs, direction of flow can be depicted using animation or color.

D.5.1.10.22 Port identification. Functional ports of components shall be clearly identified in the diagram. Identification shall agree with the port identification on the component and its installation drawing. Identification shall appear adjacent to or within the symbol and shall be as close as practical to the port being identified (see [figure D-32](#)).

D.5.1.10.23 Pattern code. Interconnecting lines in diagrams are sometimes patterned to show pressure, flow, special functions, return, drain, or different fluids during selected phases of operation. A note, preferably located in the lower left corner of the sheet, shall identify and illustrate the code for each condition used. Only those lines performing active functions for the phase shown shall be coded (see [figure D-33](#)). For IETMs, direction of flow can be depicted using animation or color.

D.5.1.10.24 Component enclosure. Where some of the components in the circuit are furnished as an assembly, it shall be so indicated in the diagram. A center line shall surround a complete symbol or group of symbols which represent the assembly. The center line represents the component enclosure. A note adjacent to the enclosure may be required to identify the component.

D.5.1.10.25 Identifying components. In many cases it may be more effective to identify the components of a circuit with index numbers rather than having the component nomenclature on the illustration. When index numbers are used, they shall be placed outside the illustration area with an arrowheaded leader line to the component. A legend shall be provided on the illustration. It shall be keyed to the illustration by the assigned index number and approved nomenclature of the indexed component. For IETMs, the legend data should be linked.

MIL-STD-3001-1A(AS) w/CHANGE 1

APPENDIX D

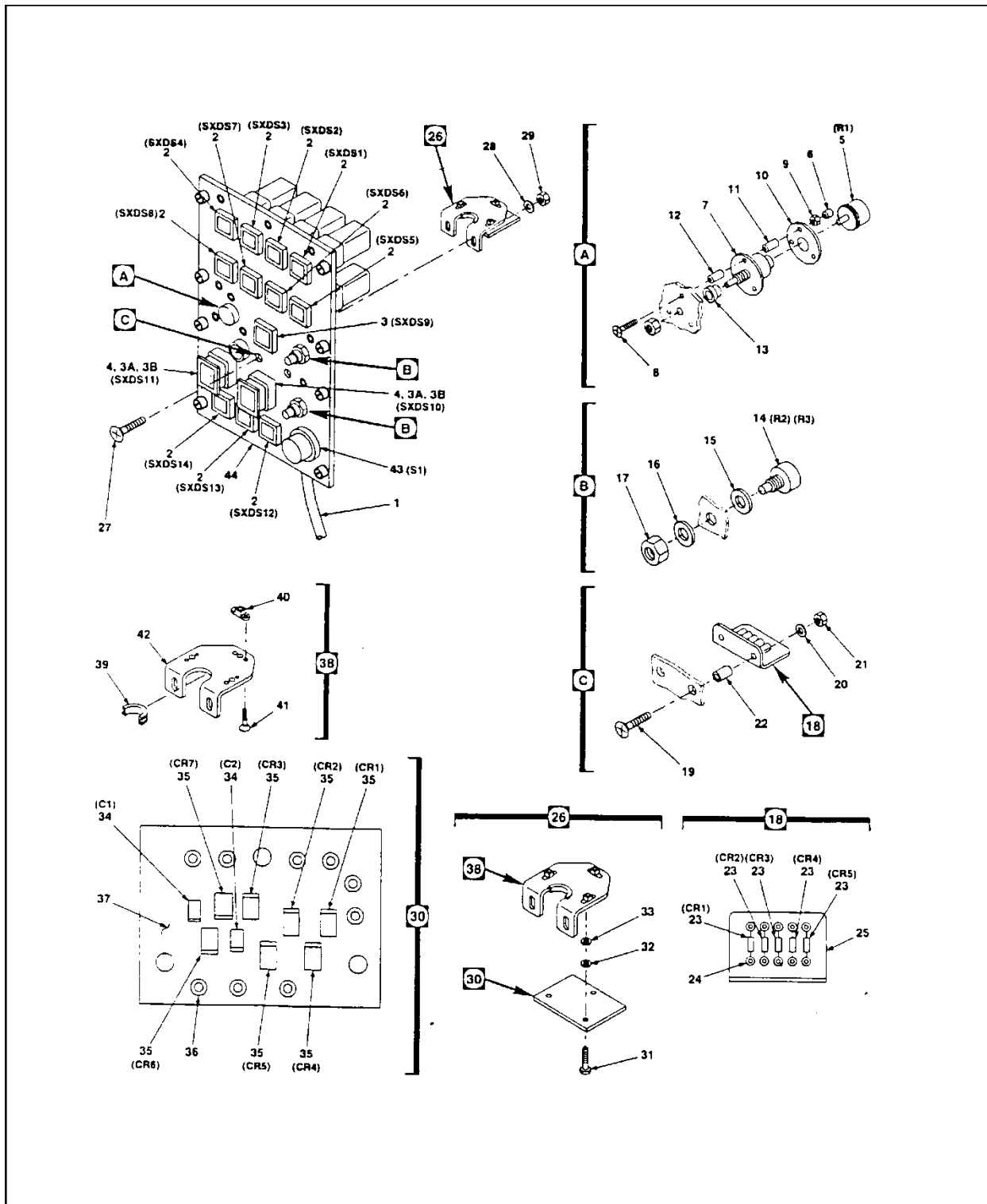

FIGURE D-1. Example of an electronic component card illustration.

MIL-STD-3001-1A(AS) w/CHANGE 1

APPENDIX D

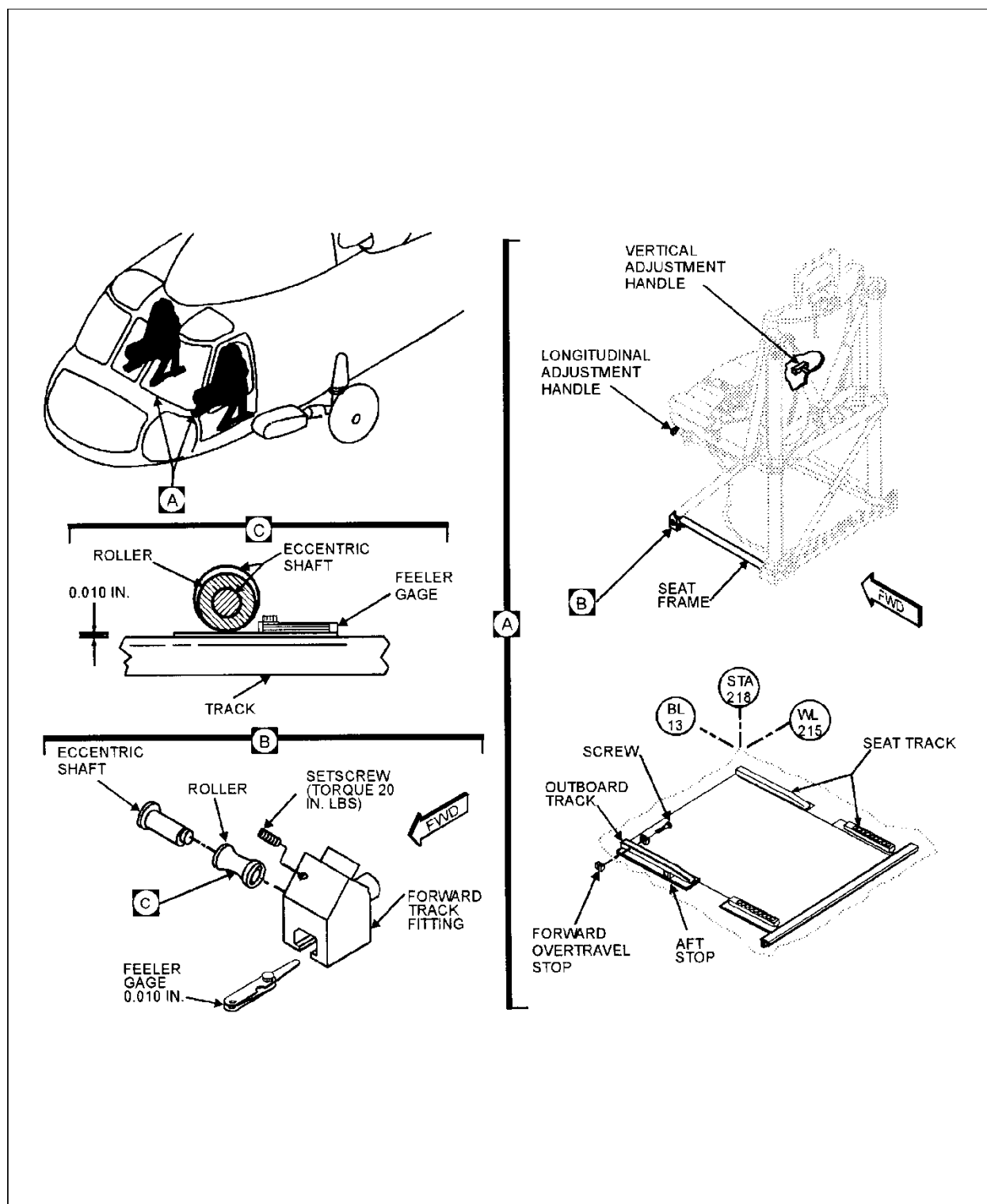

FIGURE D-2. Example of multiview, locator view and detail view illustrations.

MIL-STD-3001-1A(AS) w/CHANGE 1

APPENDIX D

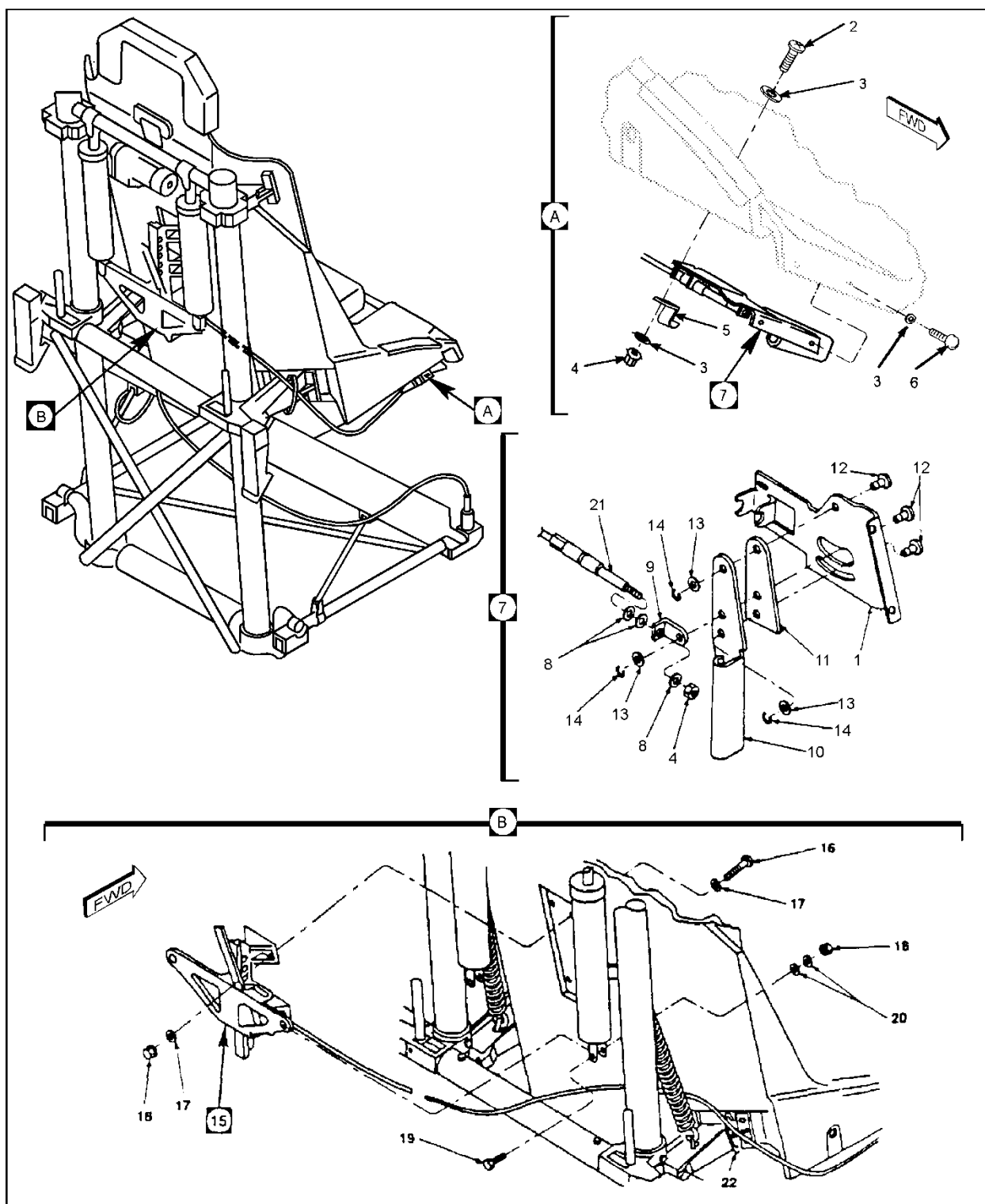

FIGURE D-2. Example of multiview, locator view and detail view illustrations. - Continued.

MIL-STD-3001-1A(AS) w/CHANGE 1

APPENDIX D

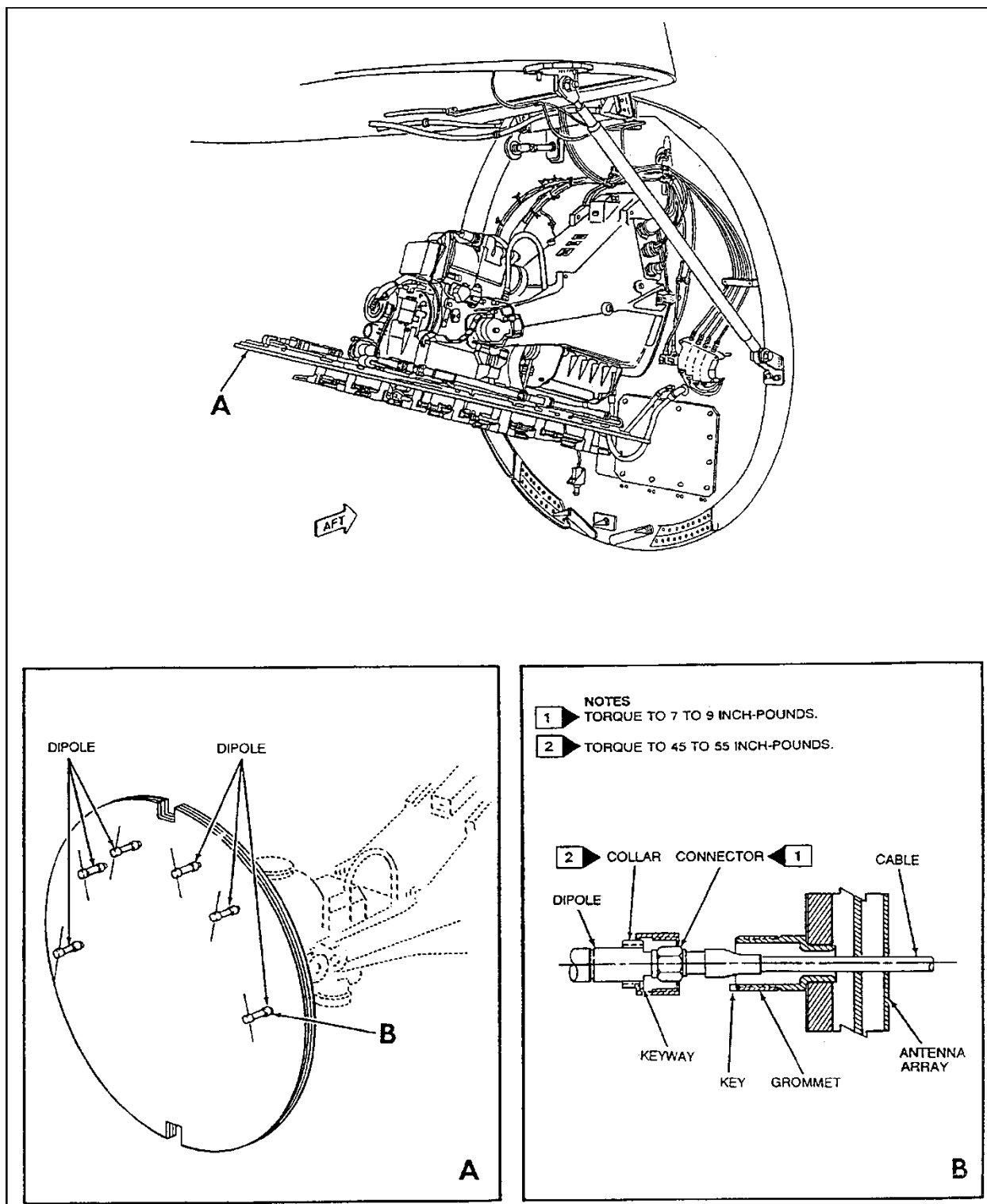

FIGURE D-2. Example of multiview, locator view and detail view illustrations. - Continued.

MIL-STD-3001-1A(AS) w/CHANGE 1

APPENDIX D

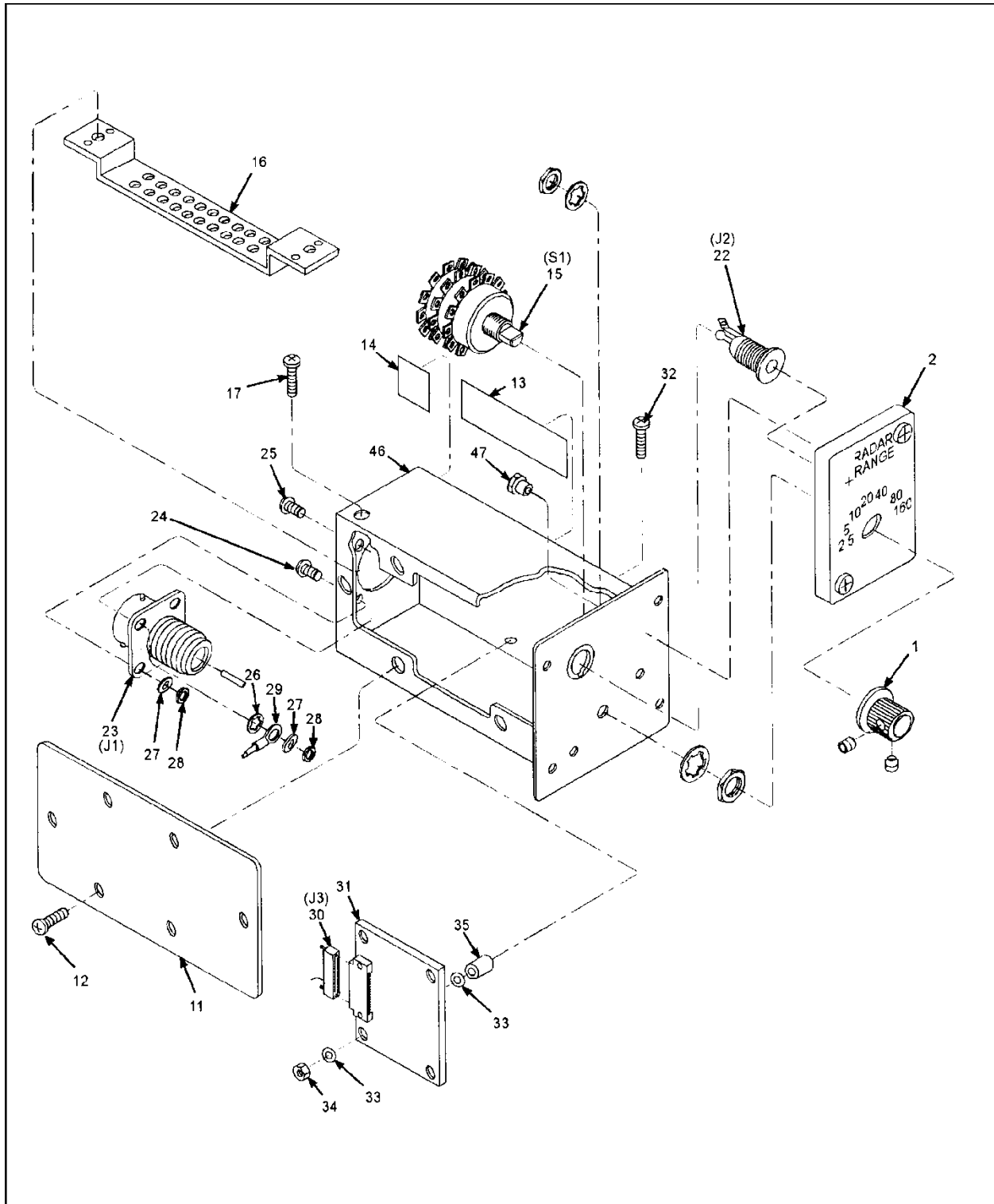

FIGURE D-3. Example of an exploded view.

MIL-STD-3001-1A(AS) w/CHANGE 1

APPENDIX D

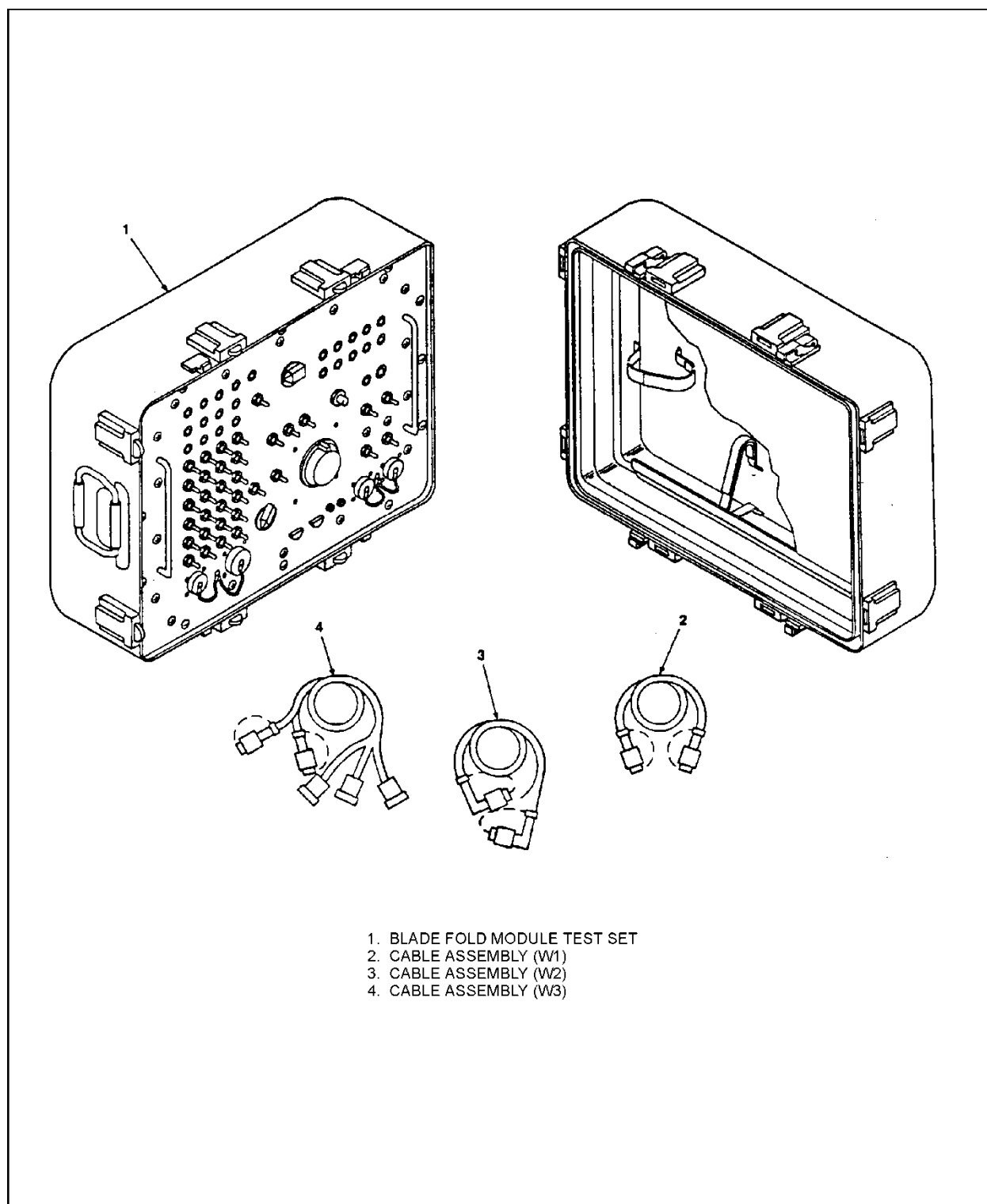

FIGURE D-4. Example of a pictorial.

MIL-STD-3001-1A(AS) w/CHANGE 1

APPENDIX D

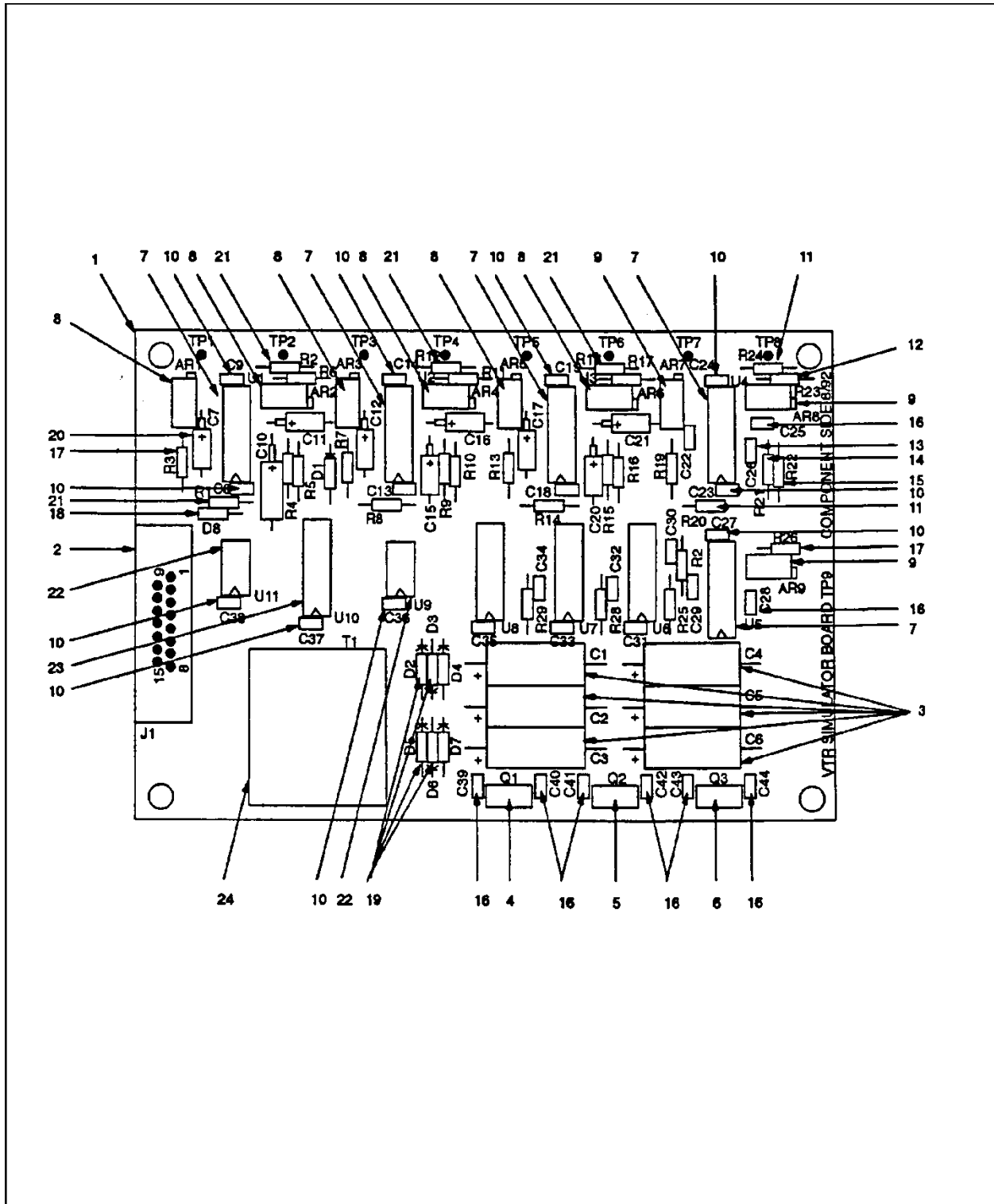
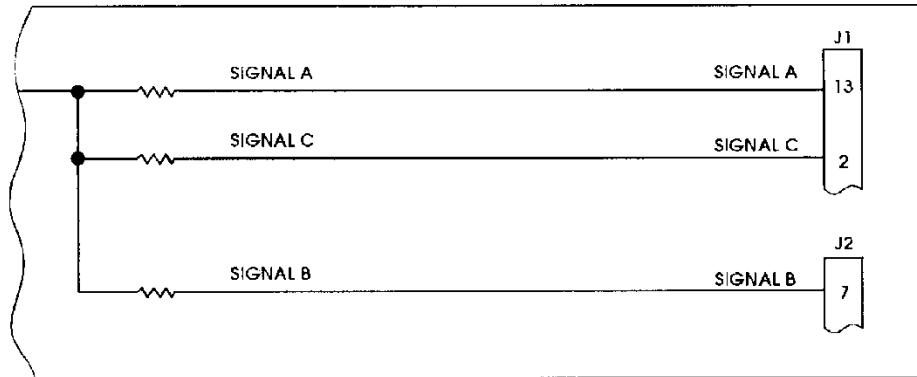

FIGURE D-4. Example of a pictorial. - Continued.

MIL-STD-3001-1A(AS) w/CHANGE 1

APPENDIX D



POINT-TO-POINT METHOD FOR SIGNAL FLOW

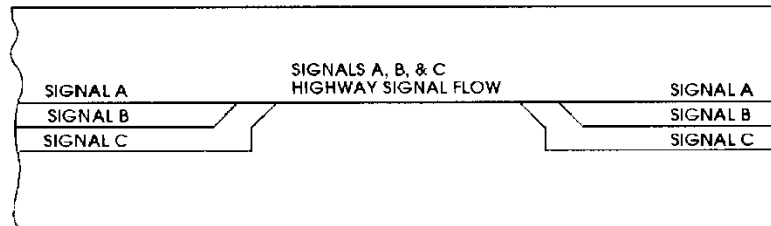

HIGHWAY METHOD FOR SIGNAL FLOW

FIGURE D-5. Example of point-to-point and highway method signal flow.

MIL-STD-3001-1A(AS) w/CHANGE 1

APPENDIX D

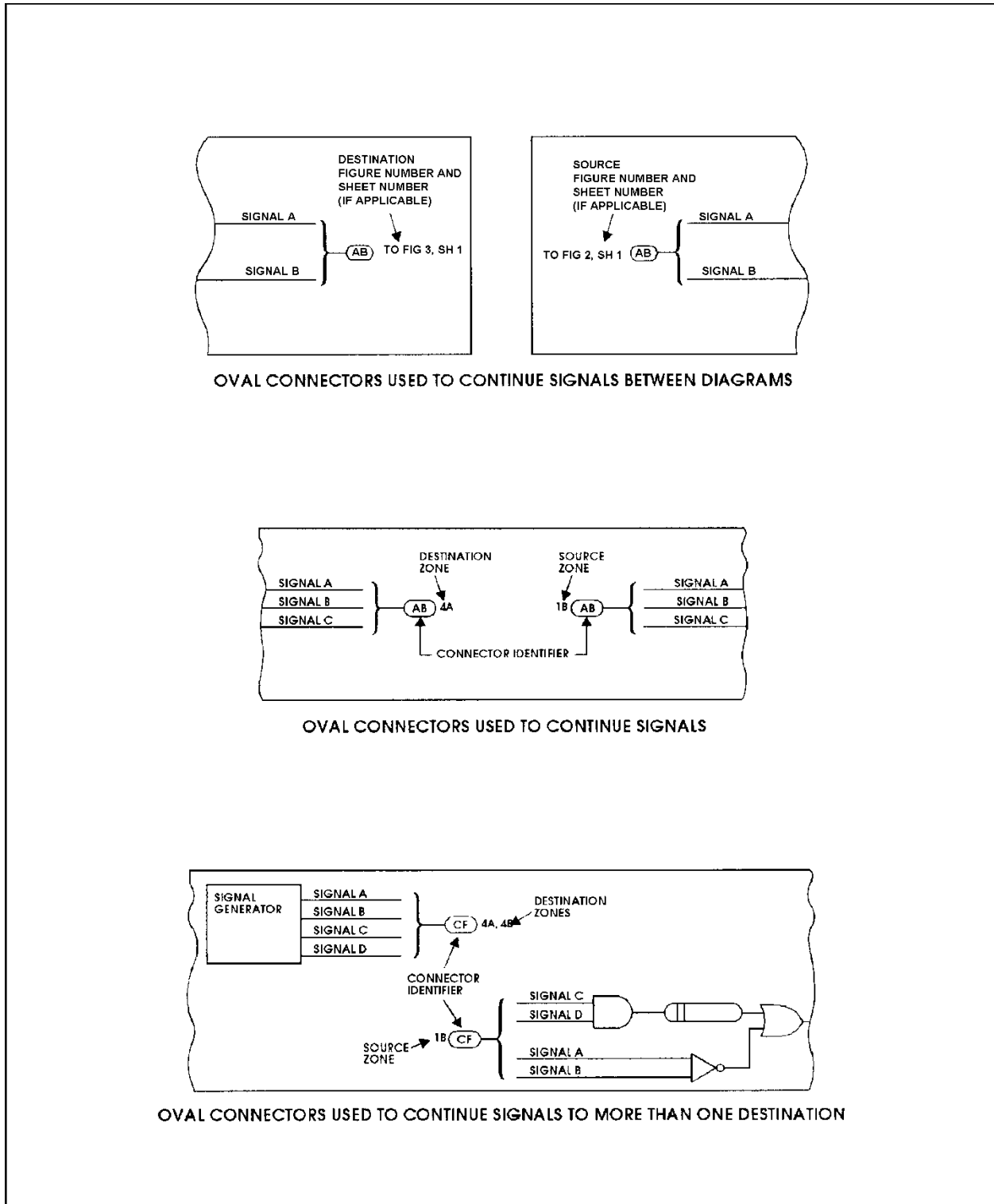
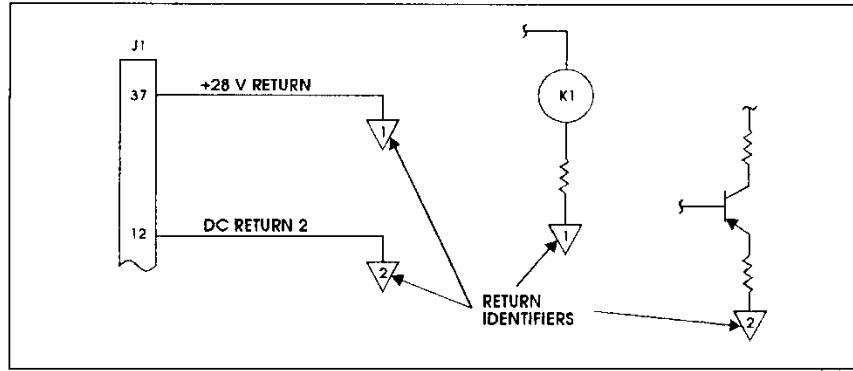

FIGURE D-6. Example of oval connectors to continue signals.

MIL-STD-3001-1A(AS) w/CHANGE 1

APPENDIX D



SIGNAL RETURNS USED TO CONTINUE SIGNAL

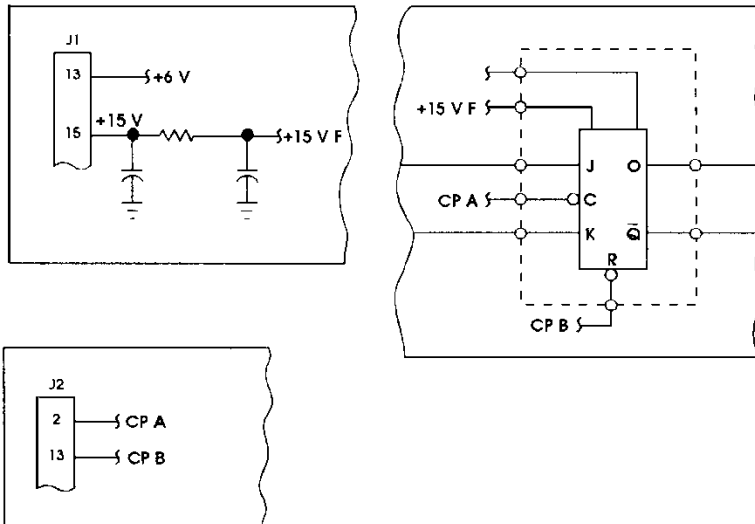

BREAKOFF SYMBOLS USED TO CONTINUE SIGNALS

FIGURE D-7. Example of signal returns and breakoff symbols.

MIL-STD-3001-1A(AS) w/CHANGE 1

APPENDIX D

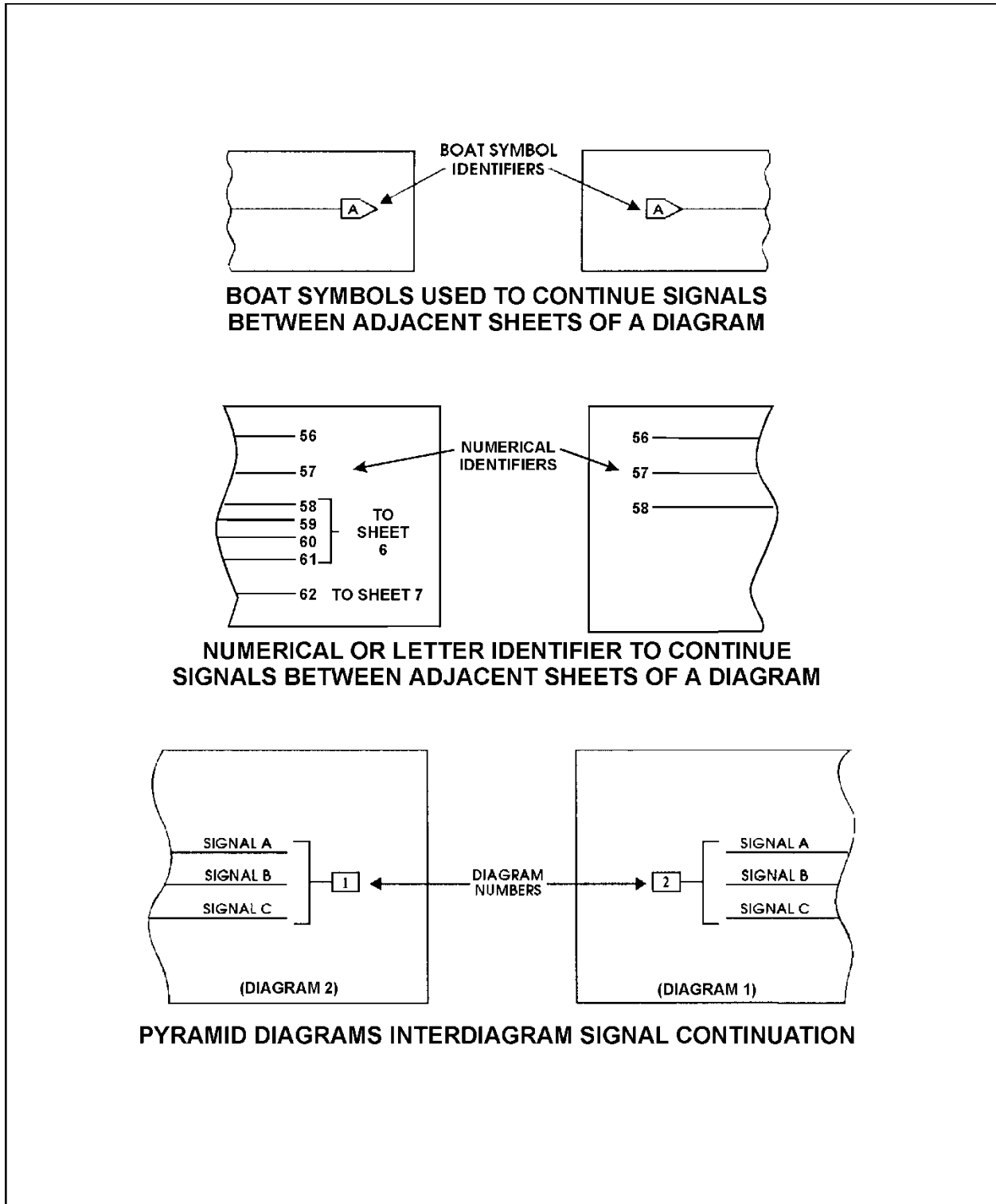
FIGURE D-8. Example of boat symbols, numerical identifiers, and pyramid method.

MIL-STD-3001-1A(AS) w/CHANGE 1

APPENDIX D

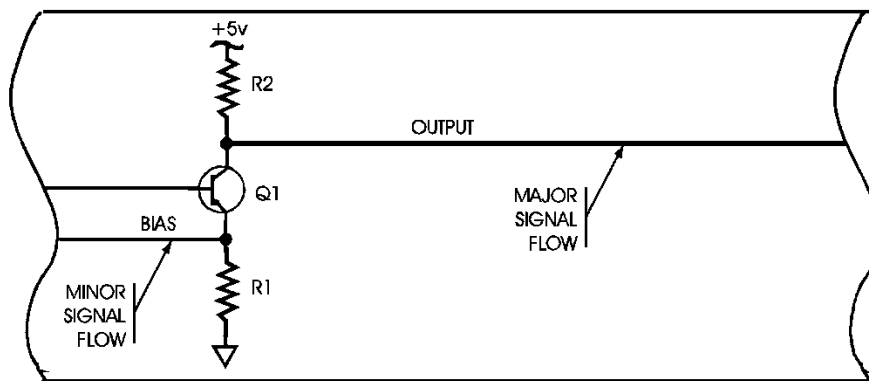

LINE WIDTH CODE USED TO INDICATE SIGNAL IMPORTANCE

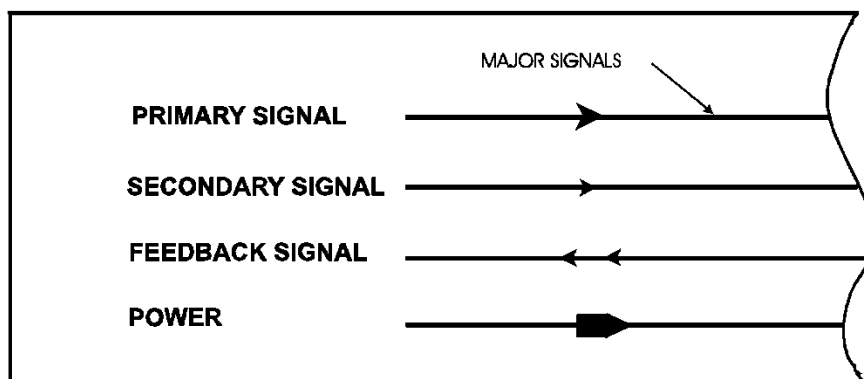

ARROWHEADS USED TO INDICATE SIGNAL TYPES

FIGURE D-9. Example of signal difference techniques.

MIL-STD-3001-1A(AS) w/CHANGE 1

APPENDIX D

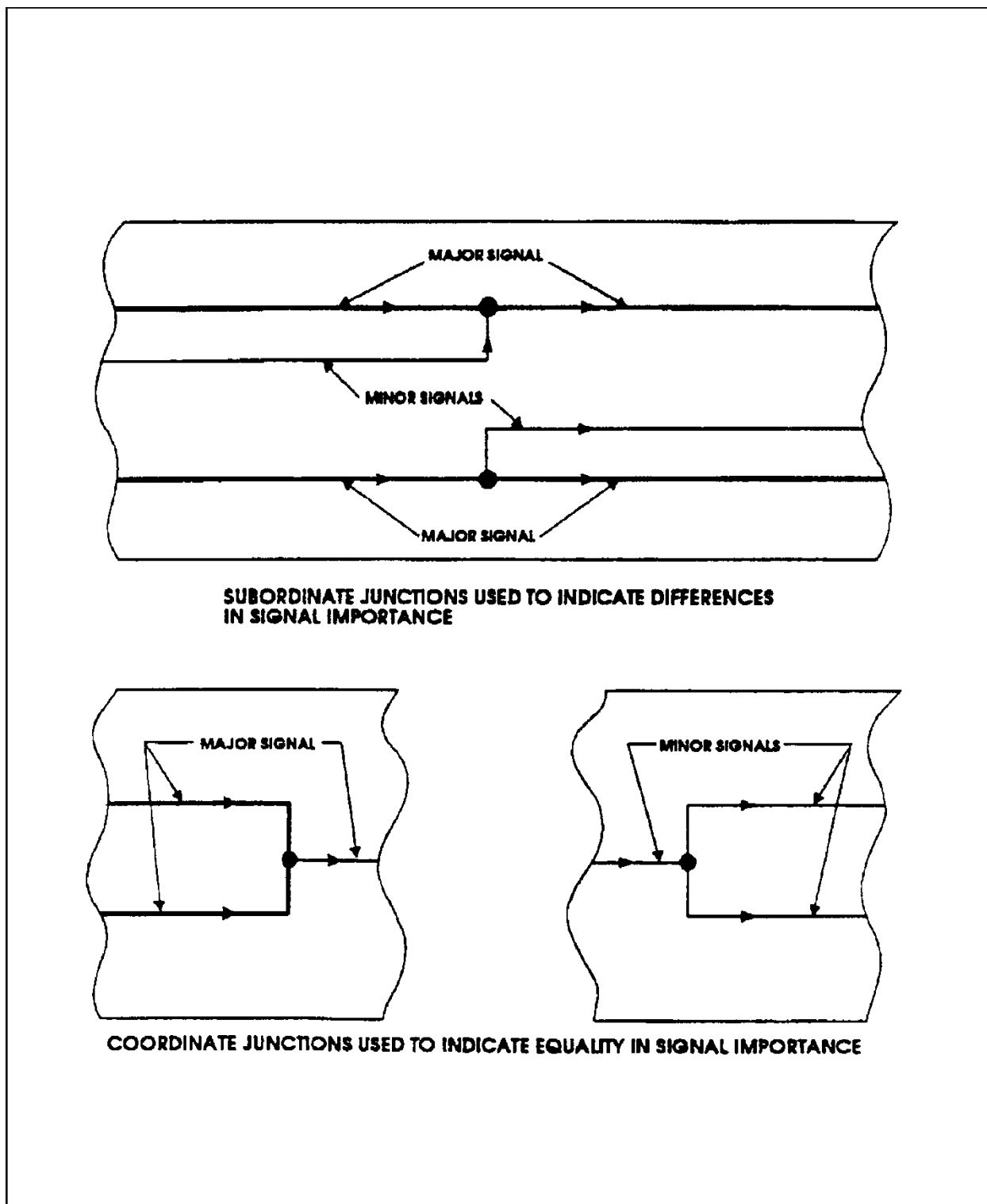

FIGURE D-10. Example of subordinate and coordinate junctions.

MIL-STD-3001-1A(AS) w/CHANGE 1

APPENDIX D

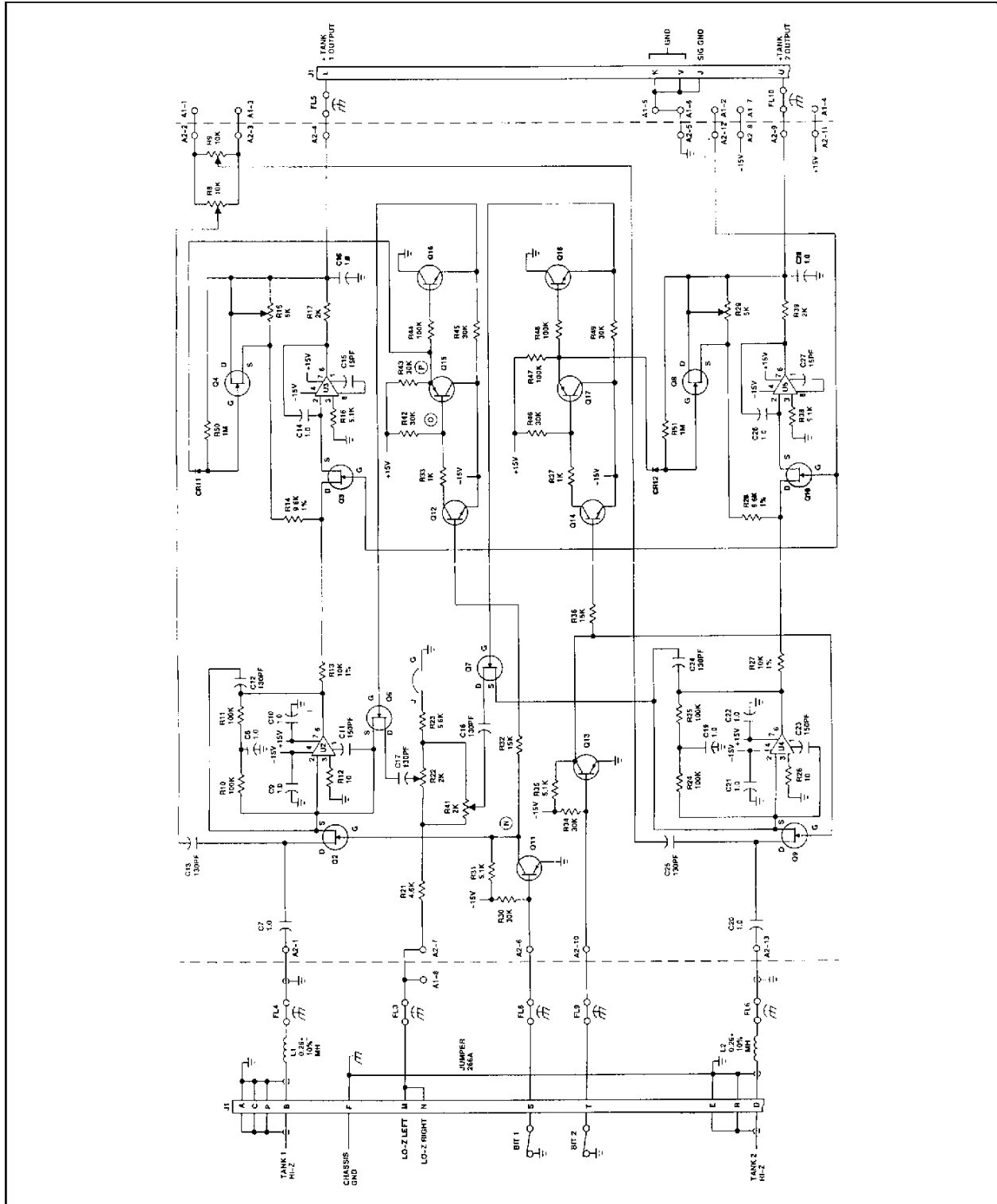

FIGURE D-11. Example of a hardware schematic diagram.

MIL-STD-3001-1A(AS) w/CHANGE 1

APPENDIX D

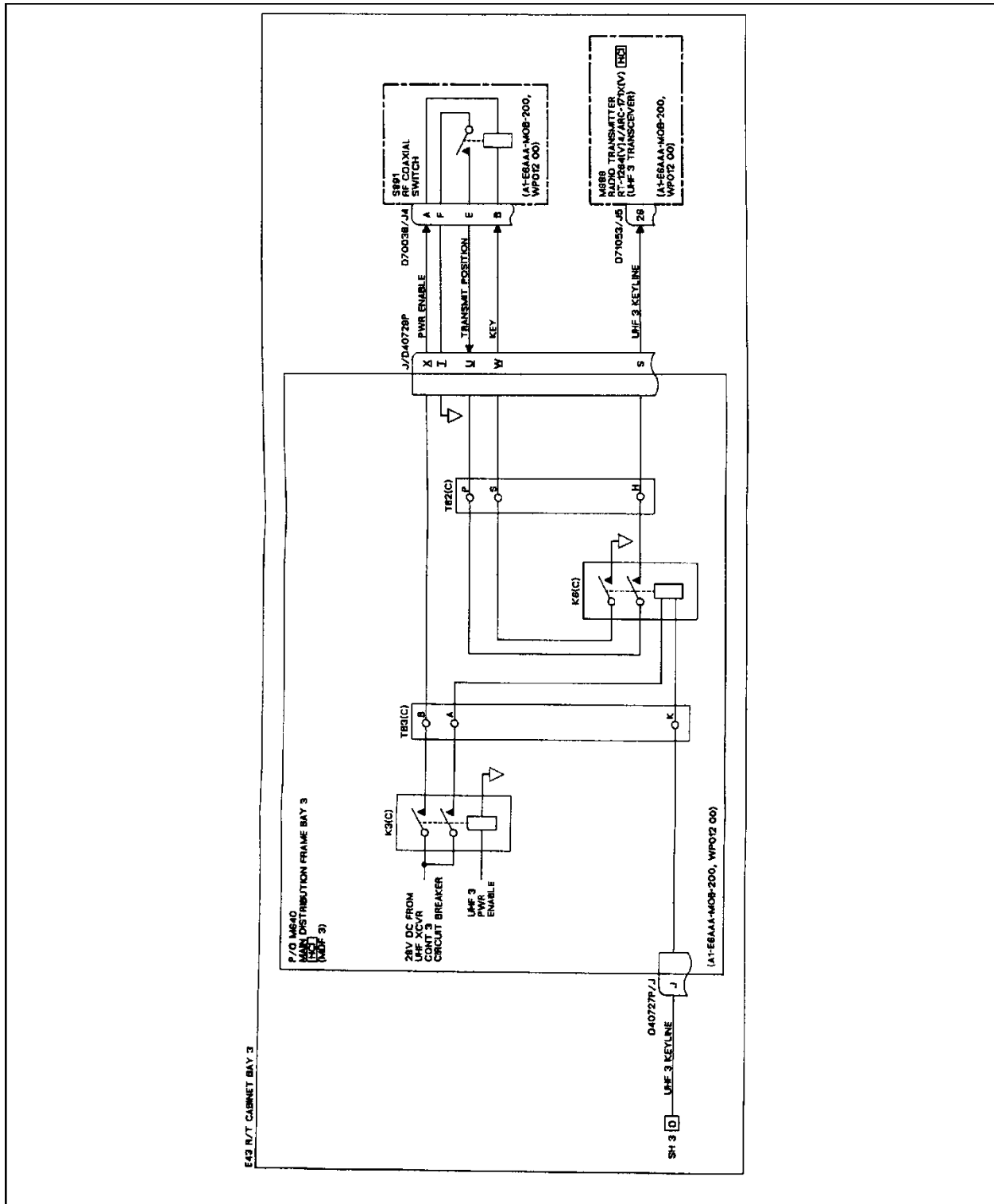

FIGURE D-12. Example of a functional schematic.

MIL-STD-3001-1A(AS) w/CHANGE 1

APPENDIX D

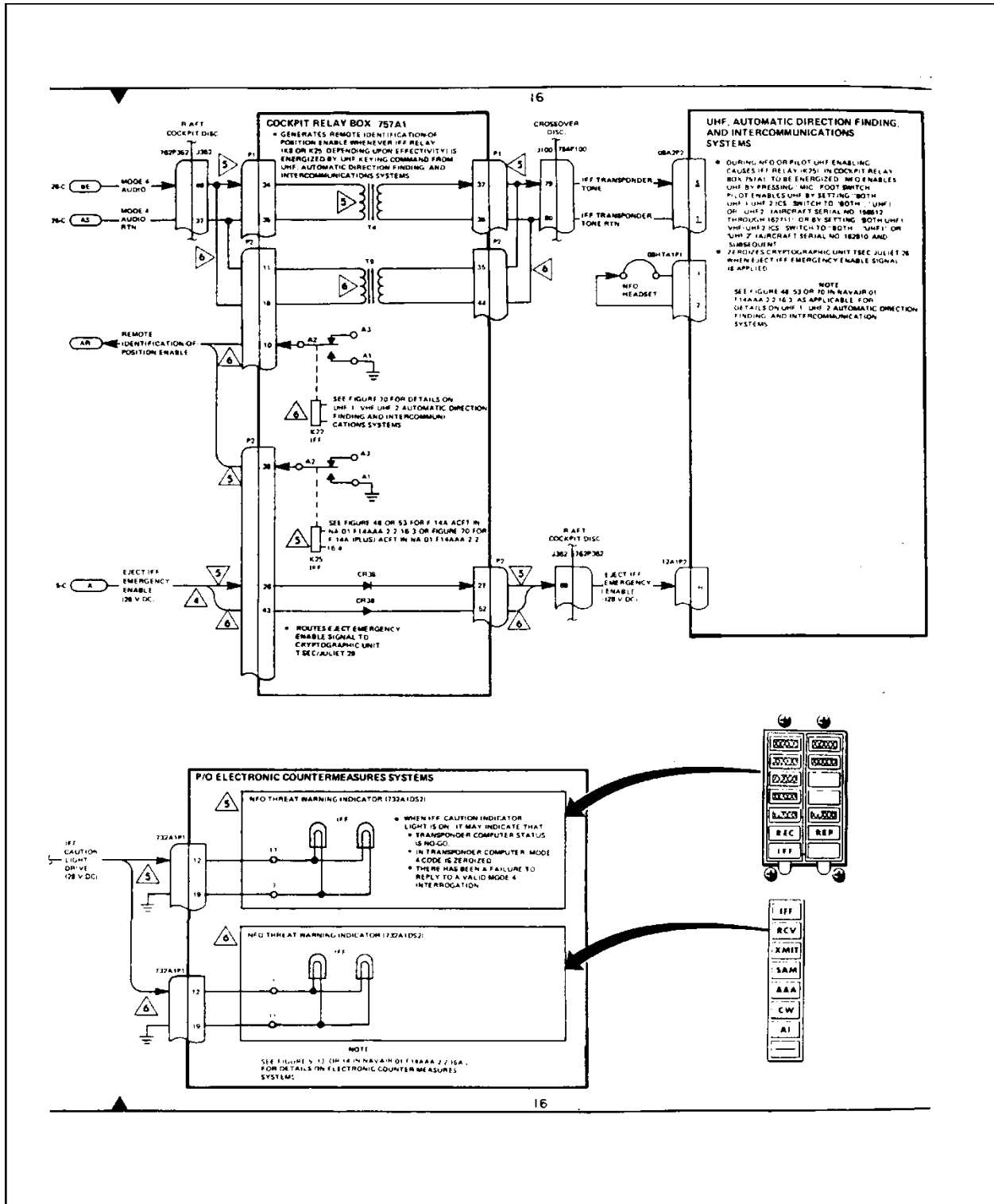

FIGURE D-13. Example of a functional flow diagram.

MIL-STD-3001-1A(AS) w/CHANGE 1

APPENDIX D

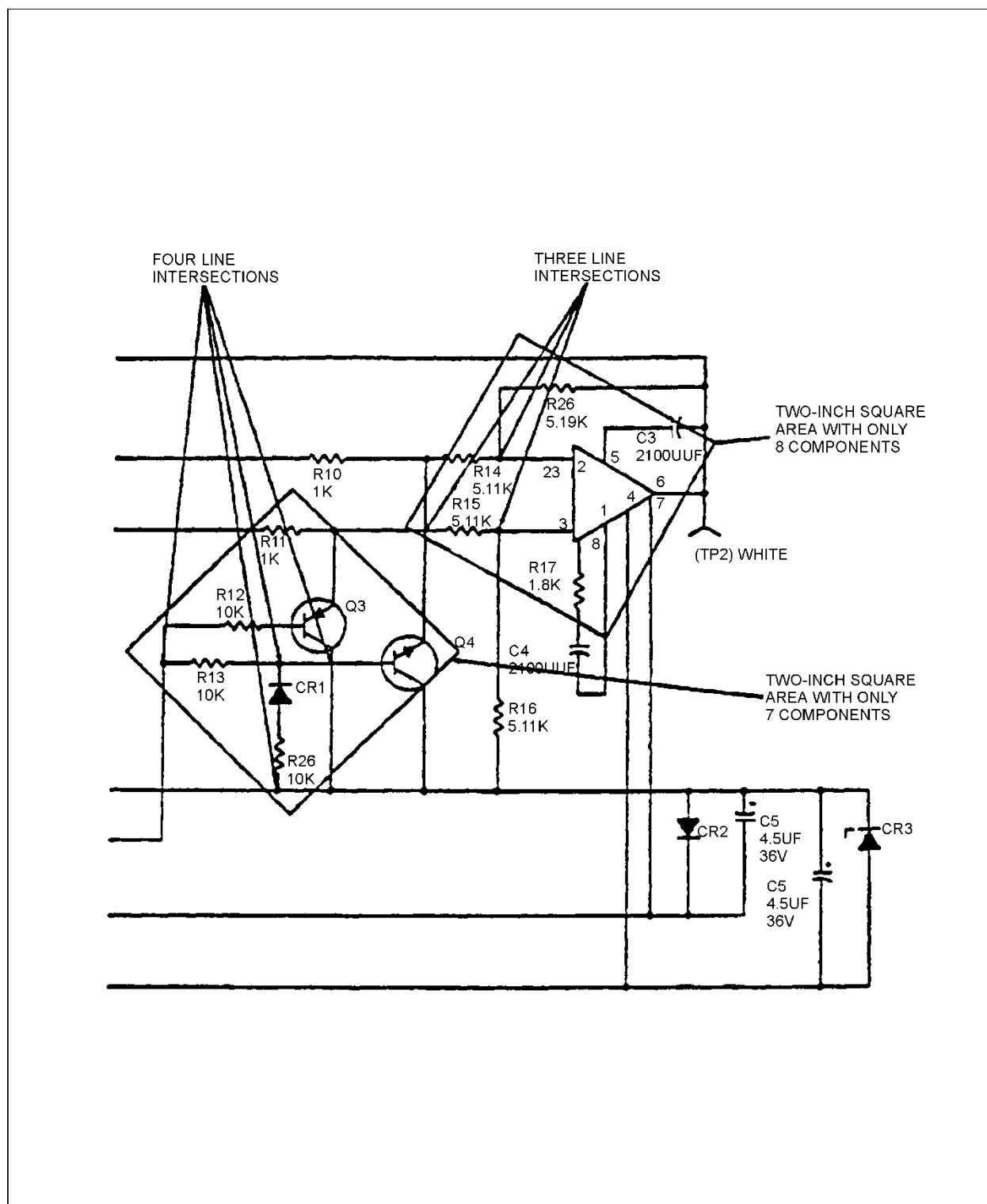

FIGURE D-14. Example of uncrowded schematic diagram.

MIL-STD-3001-1A(AS) w/CHANGE 1

APPENDIX D

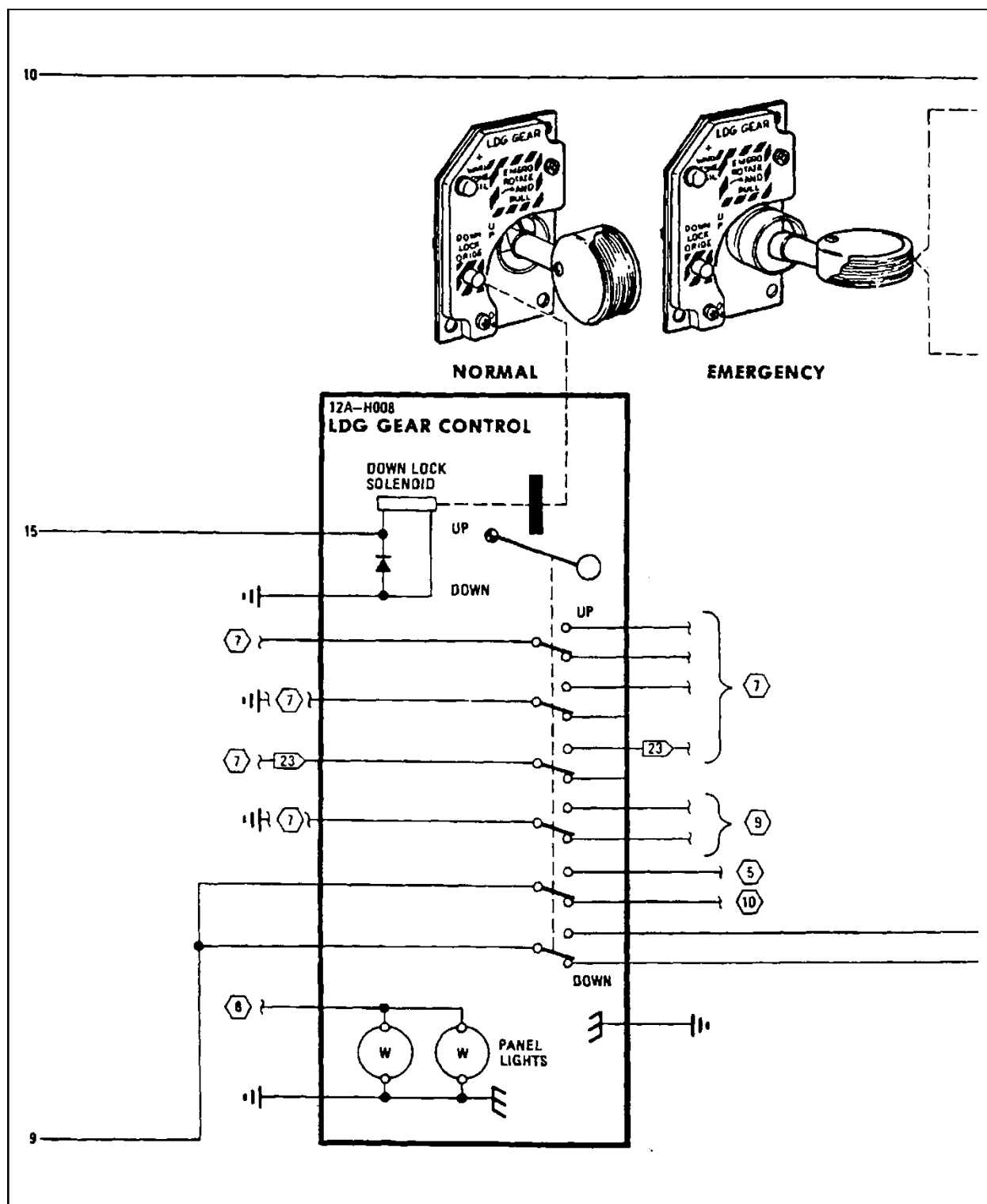

FIGURE D-15. Example of components drawn on a schematic.

MIL-STD-3001-1A(AS) w/CHANGE 1

APPENDIX D

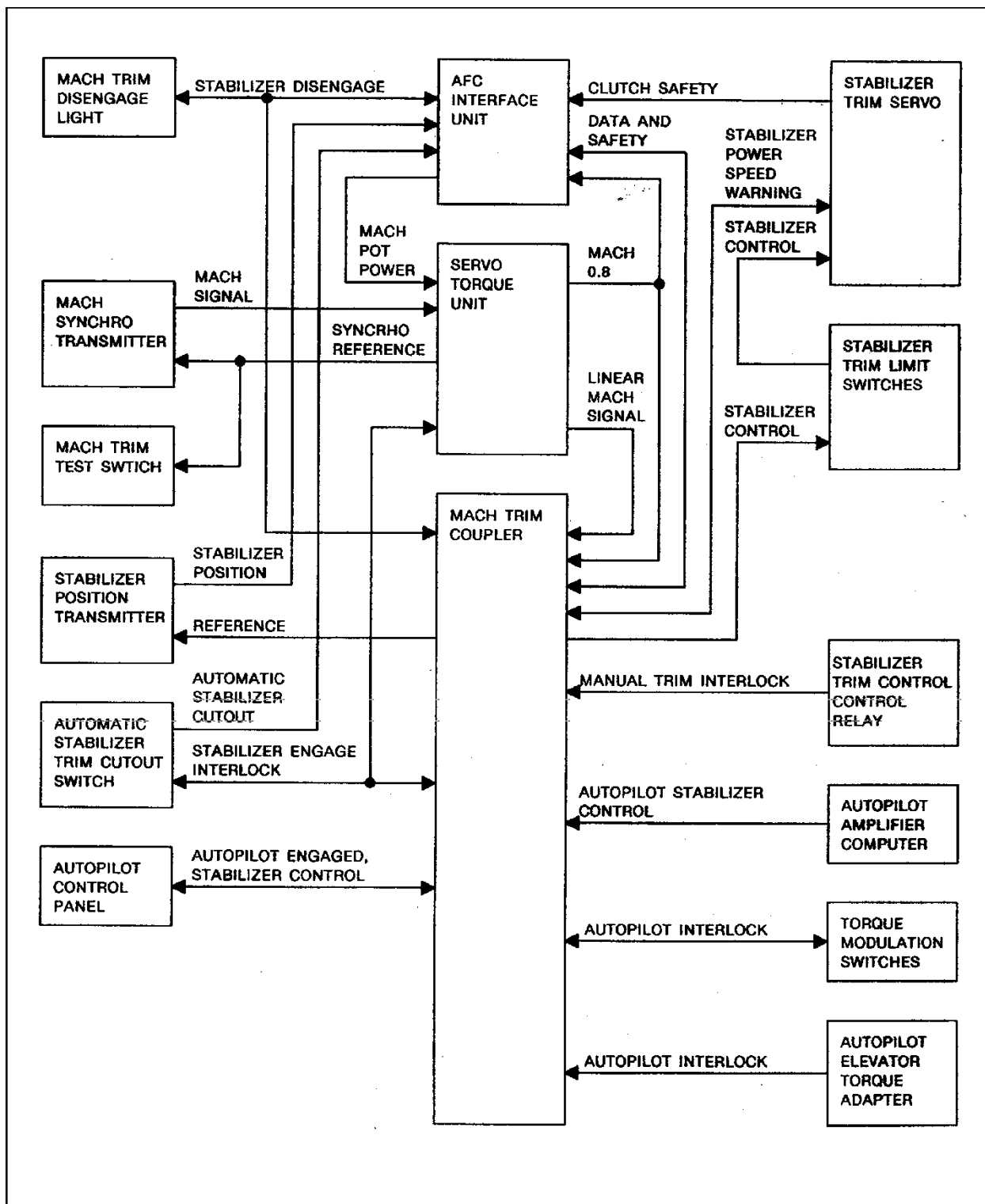

FIGURE D-16. Example of a functional block diagram.

MIL-STD-3001-1A(AS) w/CHANGE 1

APPENDIX D

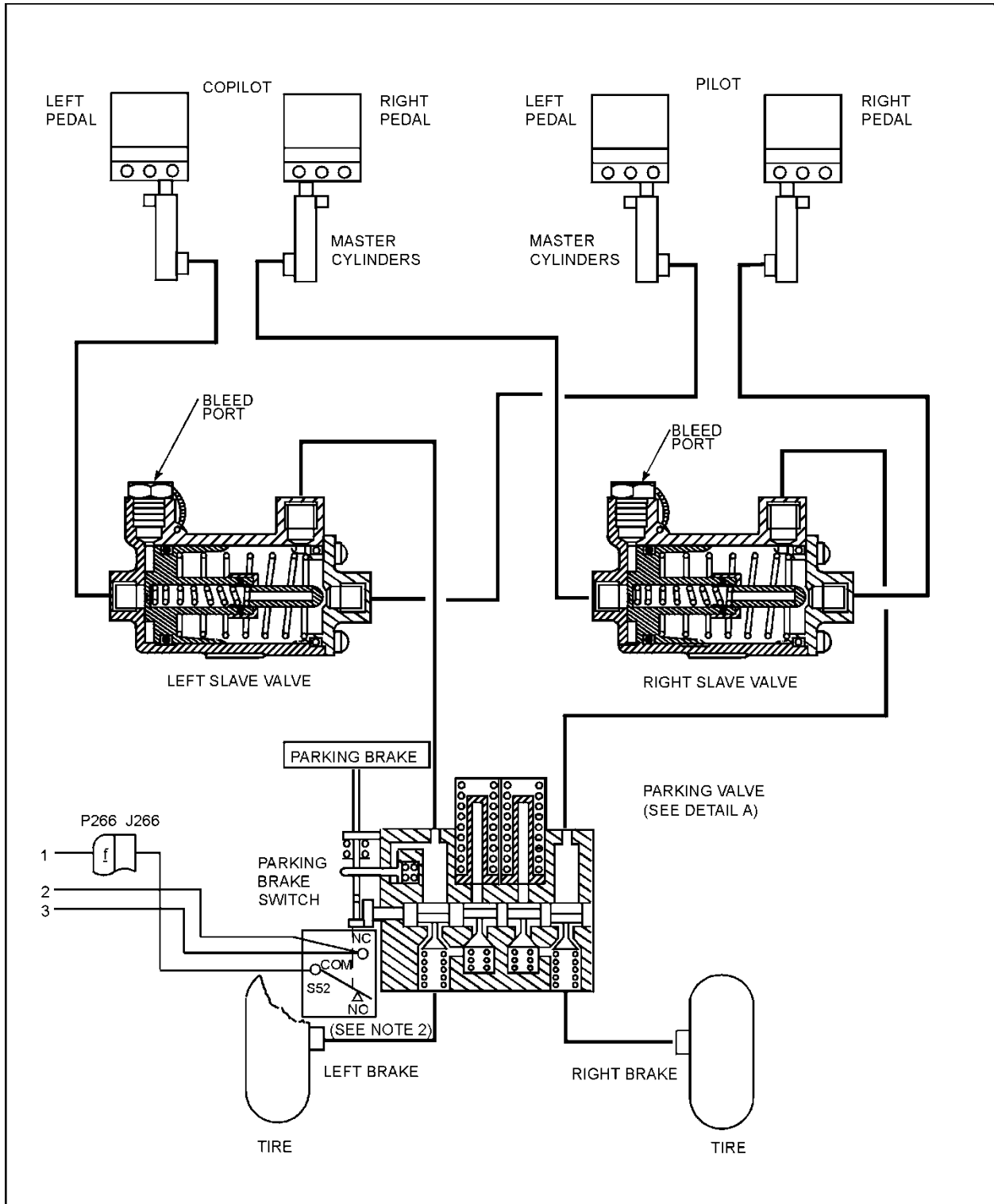

FIGURE D-17. Example of a cutaway diagram.

MIL-STD-3001-1A(AS) w/CHANGE 1

APPENDIX D

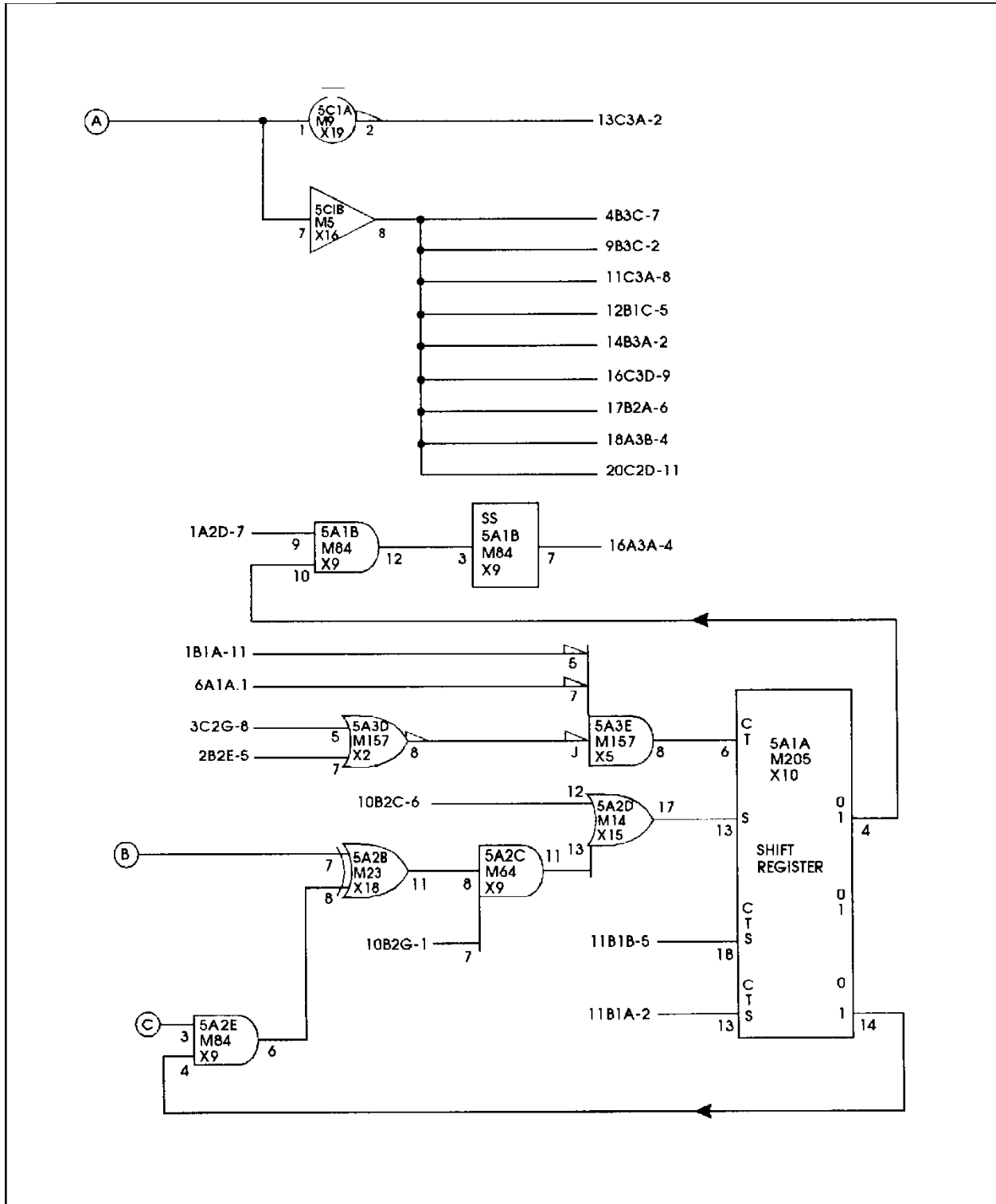

FIGURE D-18. Example of a logic diagram.

MIL-STD-3001-1A(AS) w/CHANGE 1

APPENDIX D

J - \bar{K} FLIP-FLOP TRUTH TABLE					
STARTING CONDITION (OUTPUT)		INPUT CONDITION		RESULT AT END OF CLOCK PULSE (OUTPUT)	
A	B	J	\bar{K}	A	B
L	H	L	L	NO CHANGE	
		L	H	NO CHANGE	
		H	L	H	L
		H	H	H	L
H	L	L	L	L	H
		L	H	NO CHANGE	
		H	L	L	H
		H	H	NO CHANGE	
A	B	SET	RESET	RESULT (OUTPUT)	
L	H	H	H	NO CHANGE	
		L	H	H	L
		L	L	DISALLOWED STATE	
		H	L	NO CHANGE	
H	L	H	H	NO CHANGE	
		L	H	NO CHANGE	
		L	L	DISALLOWED STATE	
		H	L	L	H

THE J- \bar{K} FLIP-FLOP IS A MULTIPURPOSE STORAGE ELEMENT WHEREIN THE K INPUT IS INTERNALLY INVERTED. DEPENDING ON THE WIRING AT THE J- \bar{K} INPUTS, THIS FF CAN BE CONFIGURED TO FUNCTION AS A J-K TYPE FF, J- \bar{K} TYPE FF, D-TYPE FF OR A T-TYPE (TOGGLE) FF.

FIGURE D-19. Example of a truth table.

MIL-STD-3001-1A(AS) w/CHANGE 1

APPENDIX D

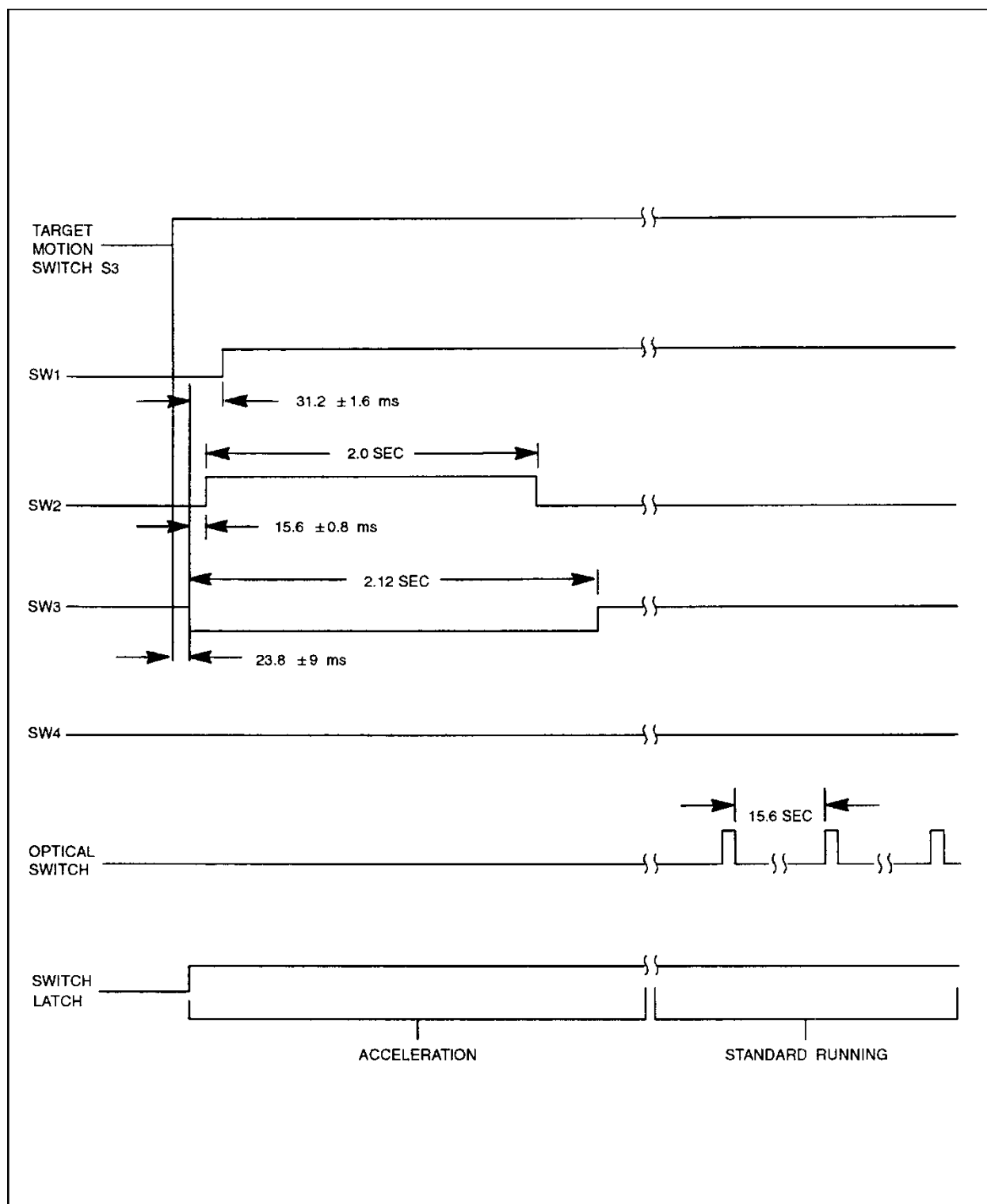

FIGURE D-20. Example of a timing diagram.

MIL-STD-3001-1A(AS) w/CHANGE 1

APPENDIX D

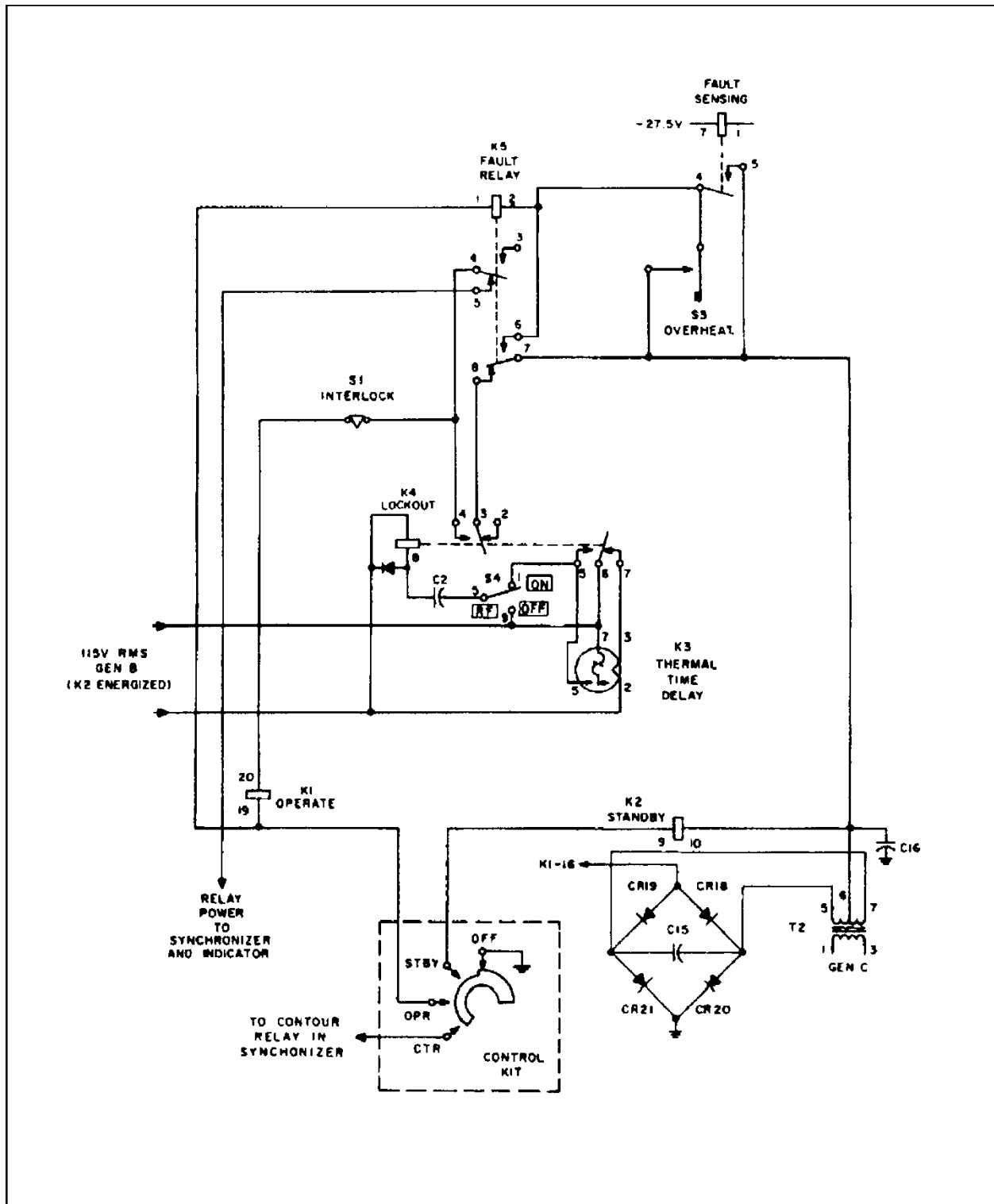

FIGURE D-21. Example of a simplified diagram.

MIL-STD-3001-1A(AS) w/CHANGE 1

APPENDIX D

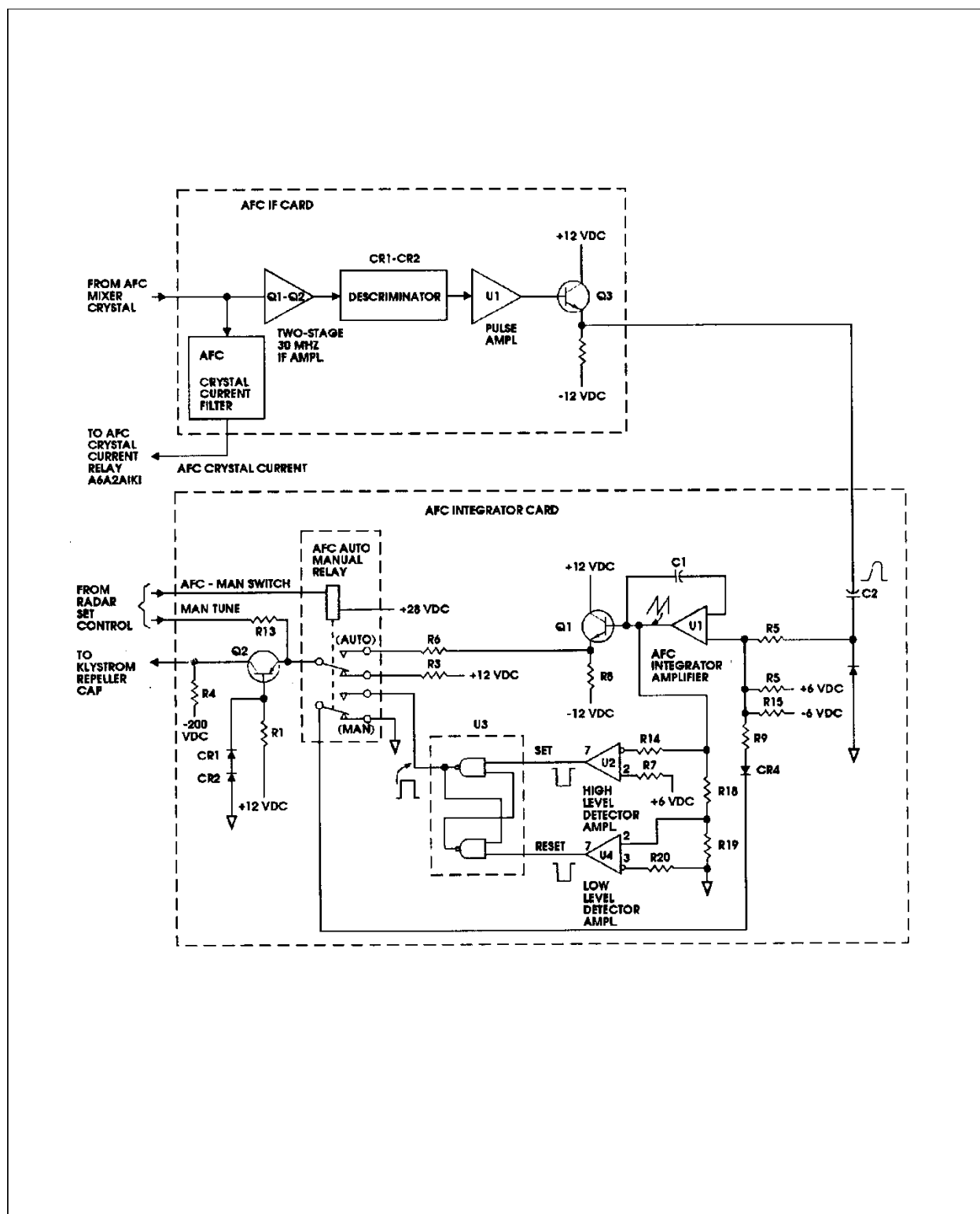

FIGURE D-22. Example of a partial diagram.

MIL-STD-3001-1A(AS) w/CHANGE 1

APPENDIX D

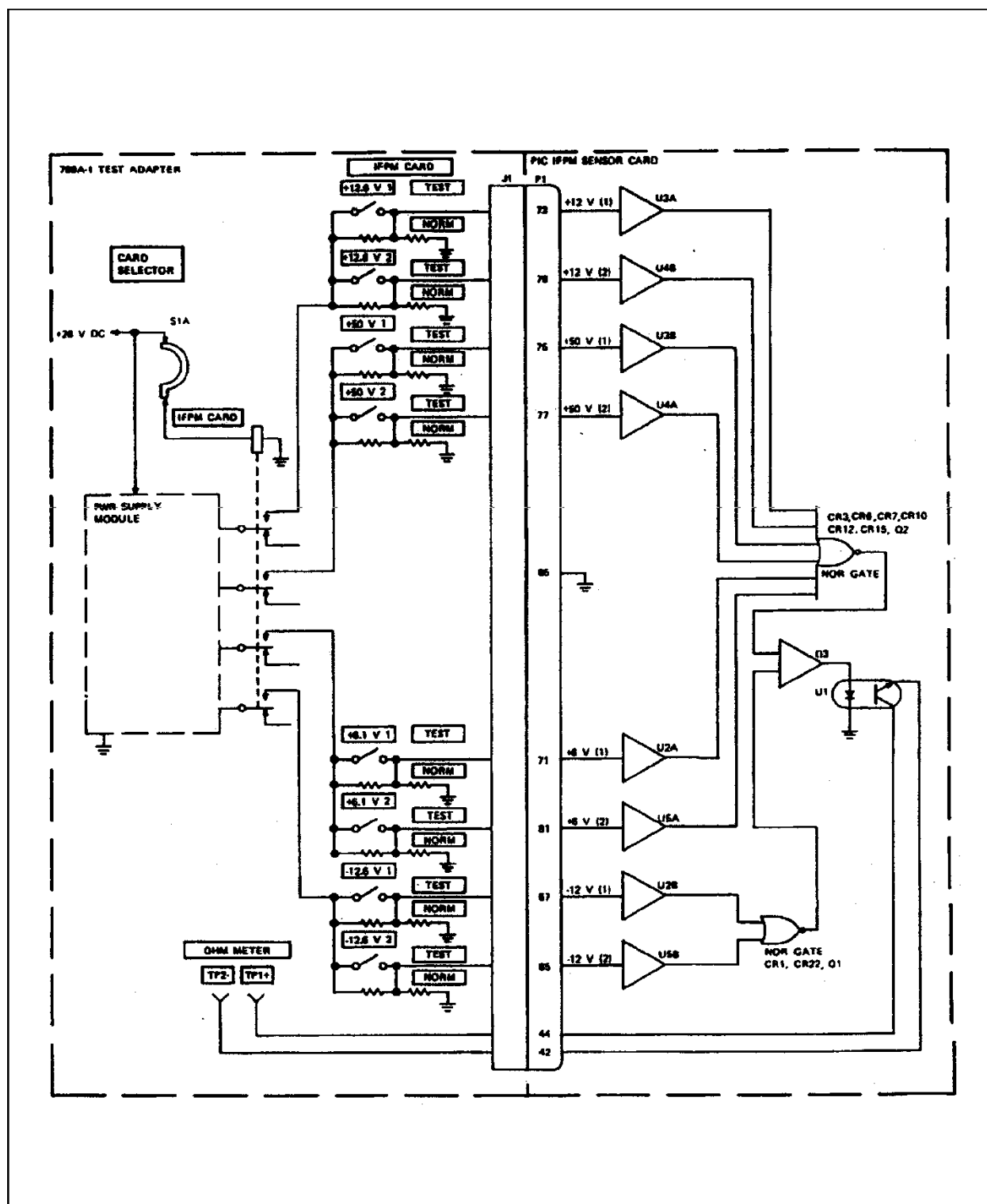

FIGURE D-23. Example of a test diagram.

MIL-STD-3001-1A(AS) w/CHANGE 1

APPENDIX D

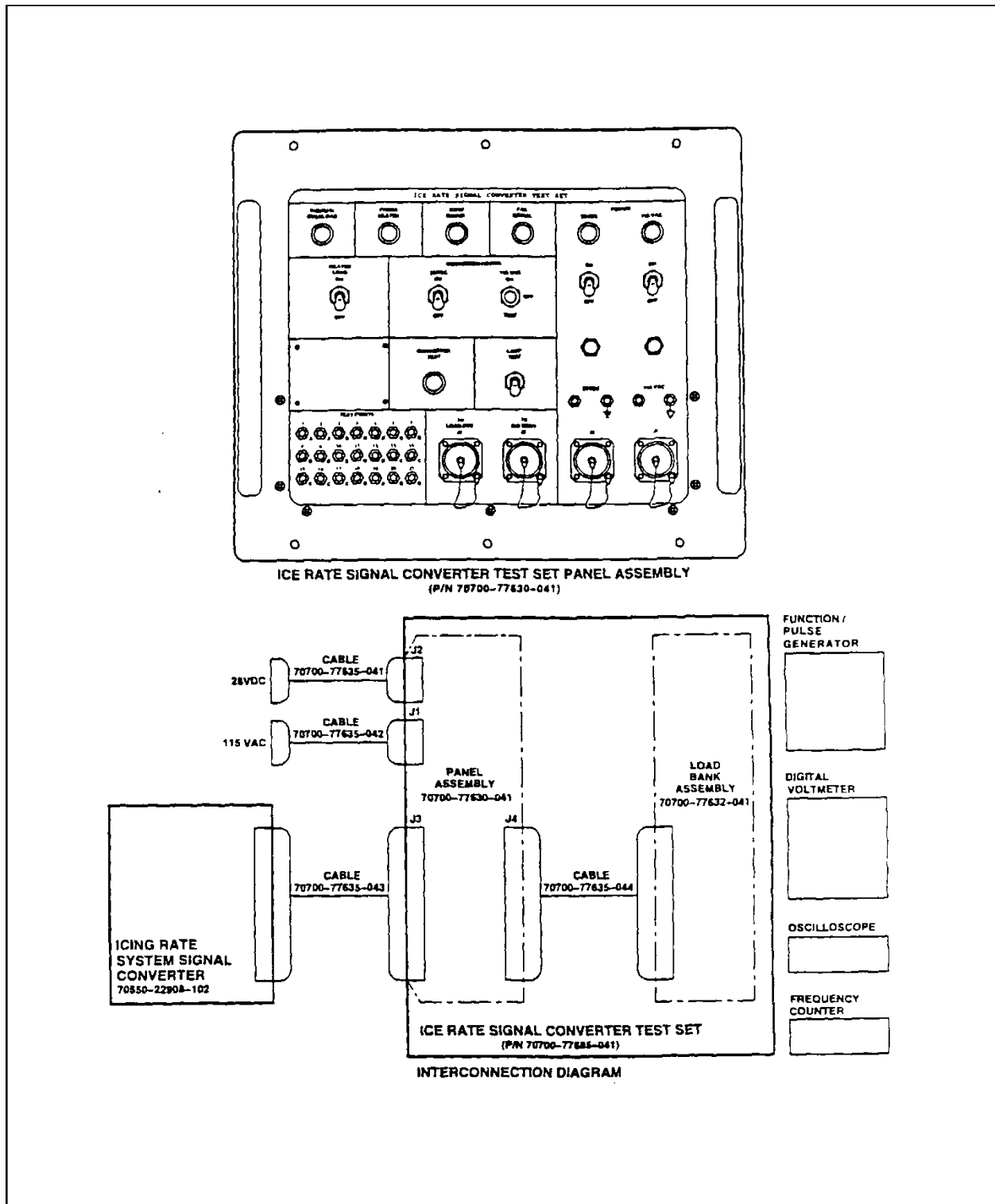

FIGURE D-24. Example of a test setup diagram.

MIL-STD-3001-1A(AS) w/CHANGE 1

APPENDIX D

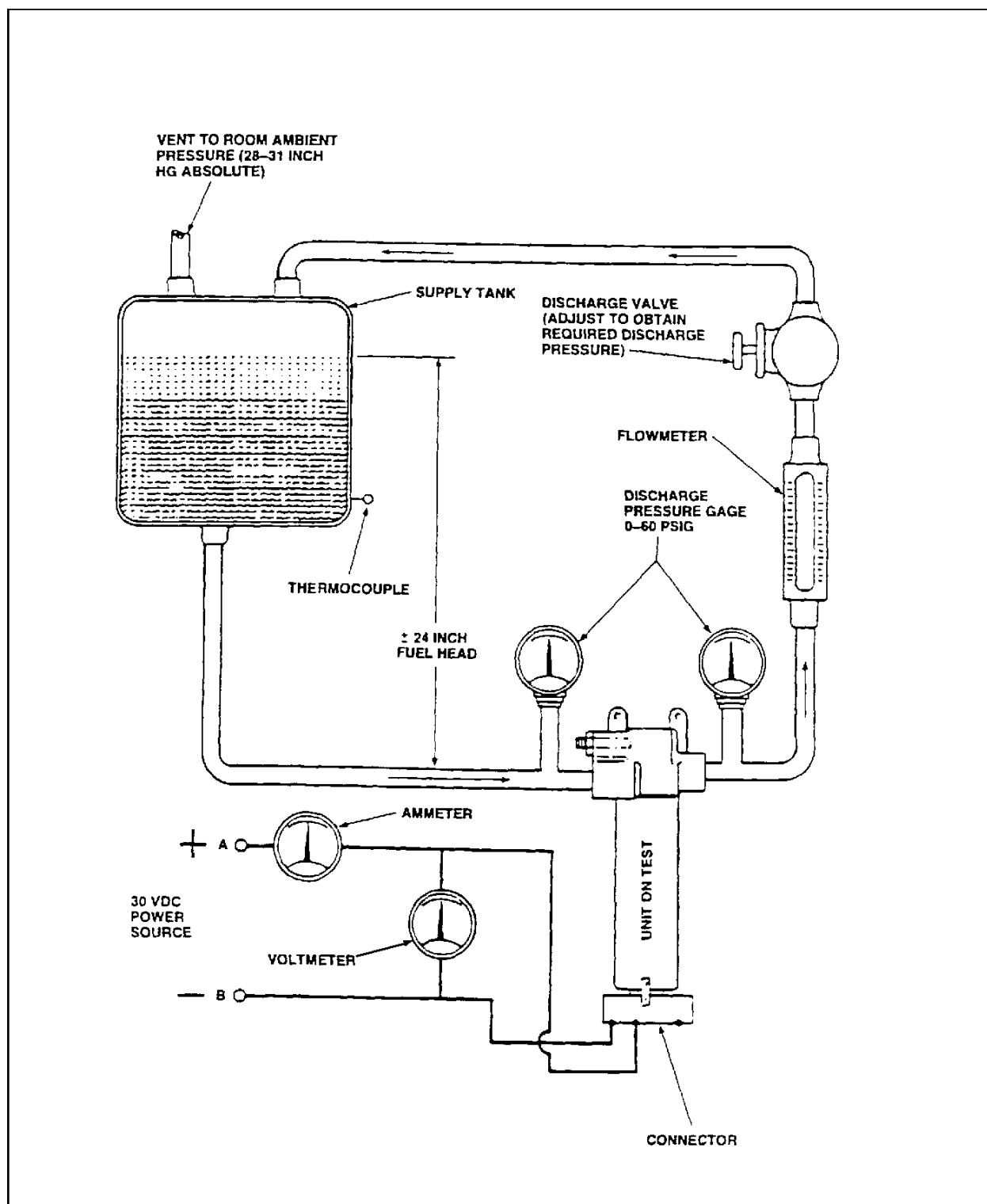

FIGURE D-24. Example of a test setup diagram. - Continued.

MIL-STD-3001-1A(AS) w/CHANGE 1

APPENDIX D

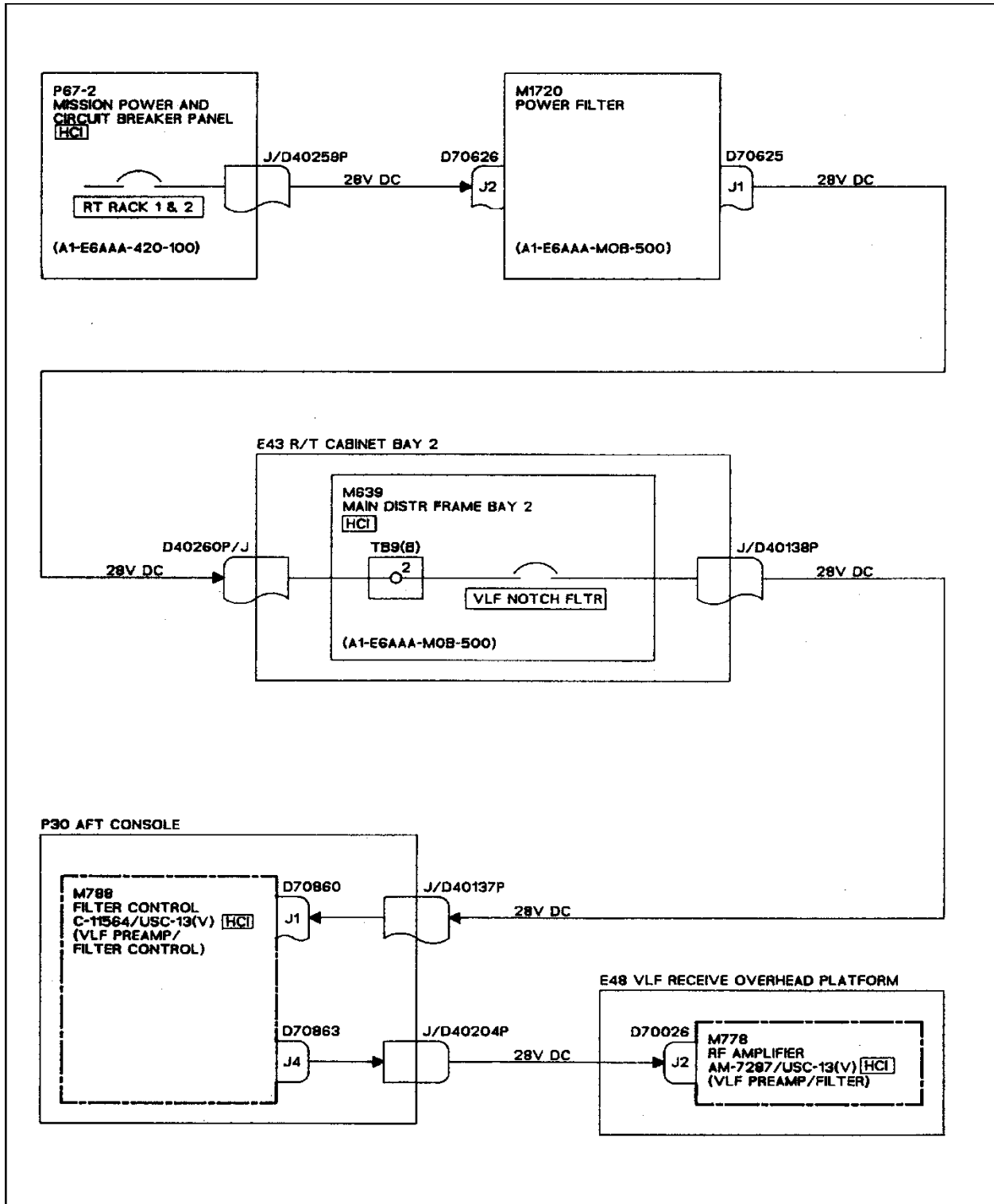

FIGURE D-25. Example of a power distribution diagram.

MIL-STD-3001-1A(AS) w/CHANGE 1

APPENDIX D

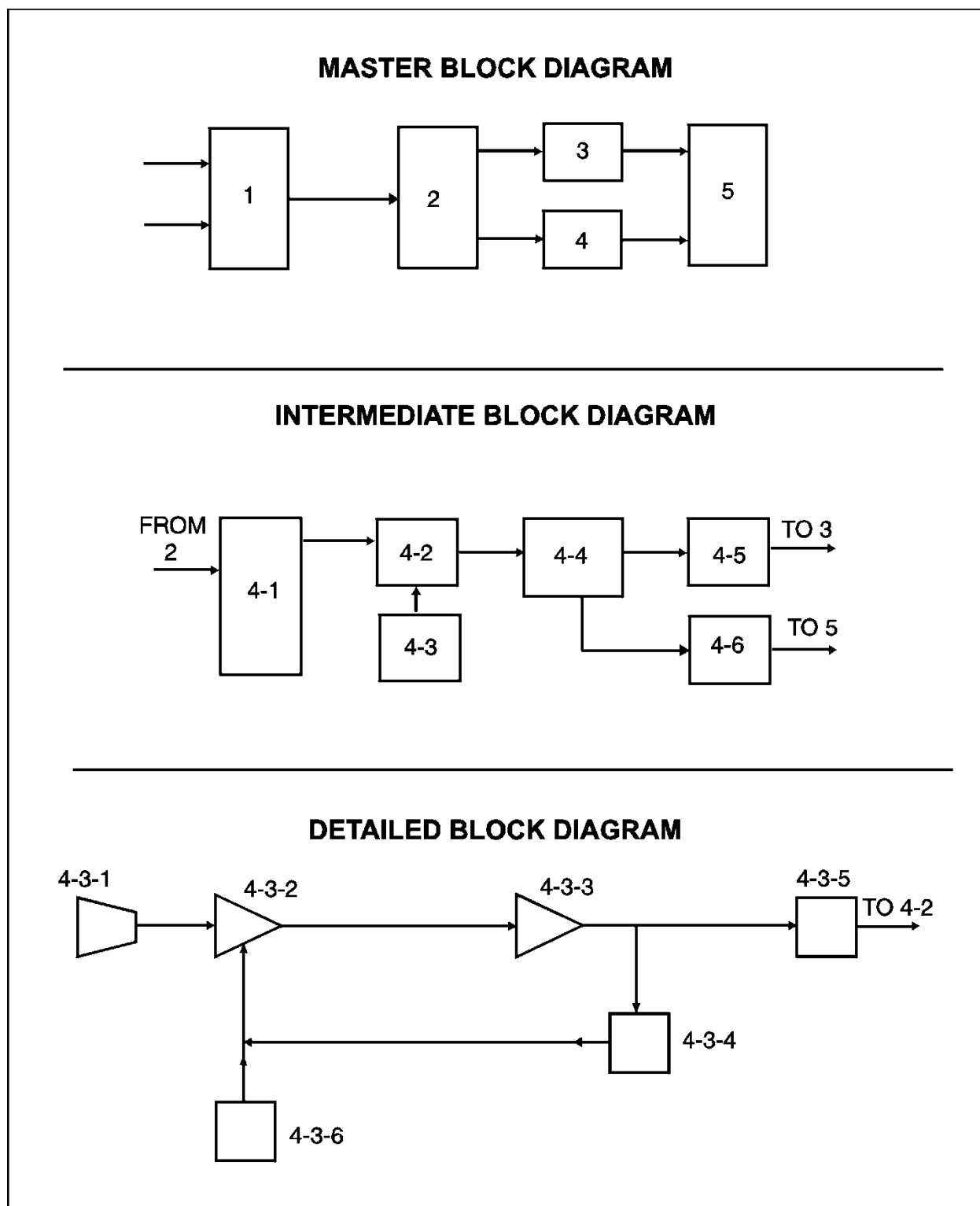

FIGURE D-26. Example of a pyramid diagram.

MIL-STD-3001-1A(AS) w/CHANGE 1

APPENDIX D

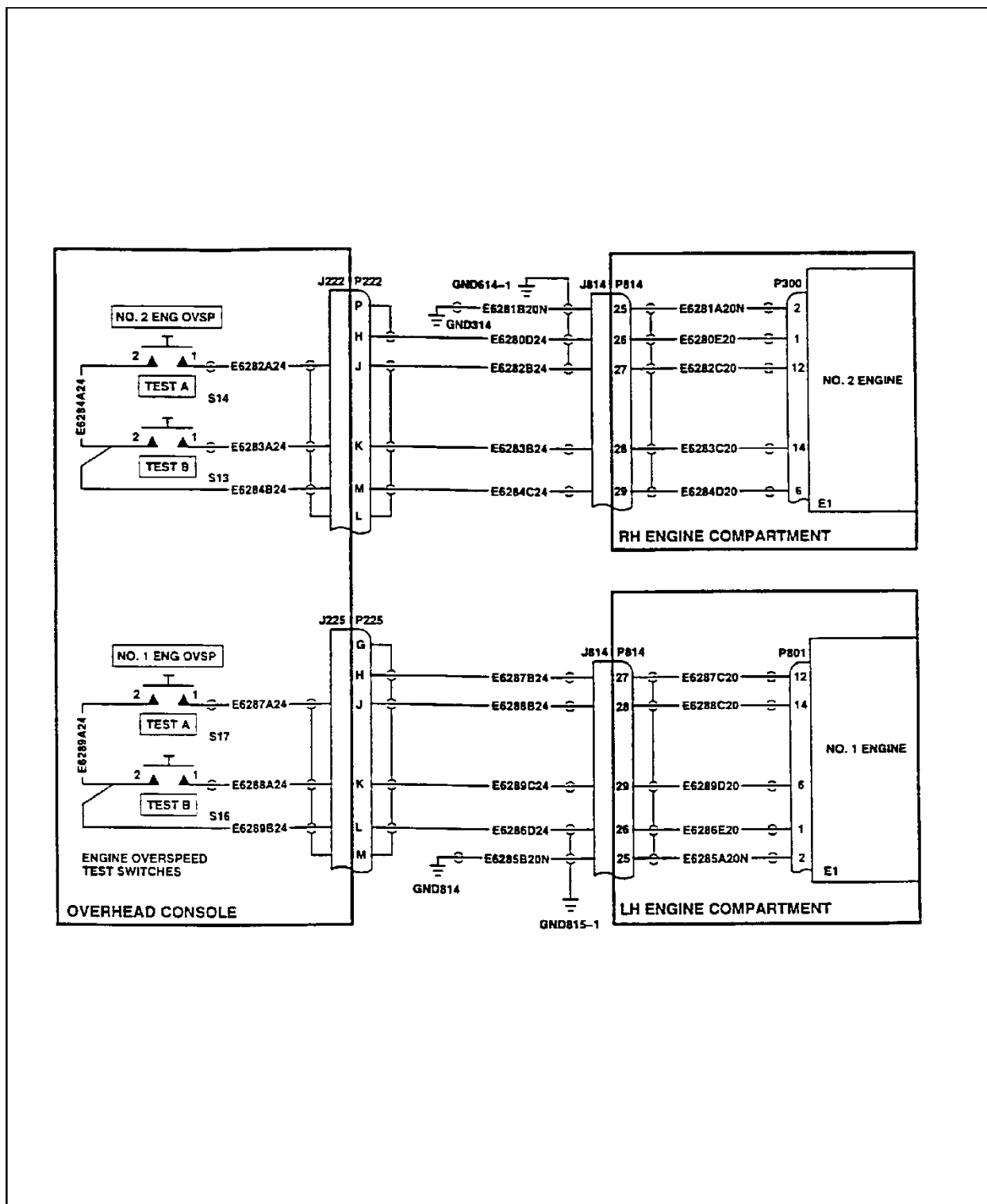

FIGURE D-27. Example of a wiring diagram.

MIL-STD-3001-1A(AS) w/CHANGE 1

APPENDIX D

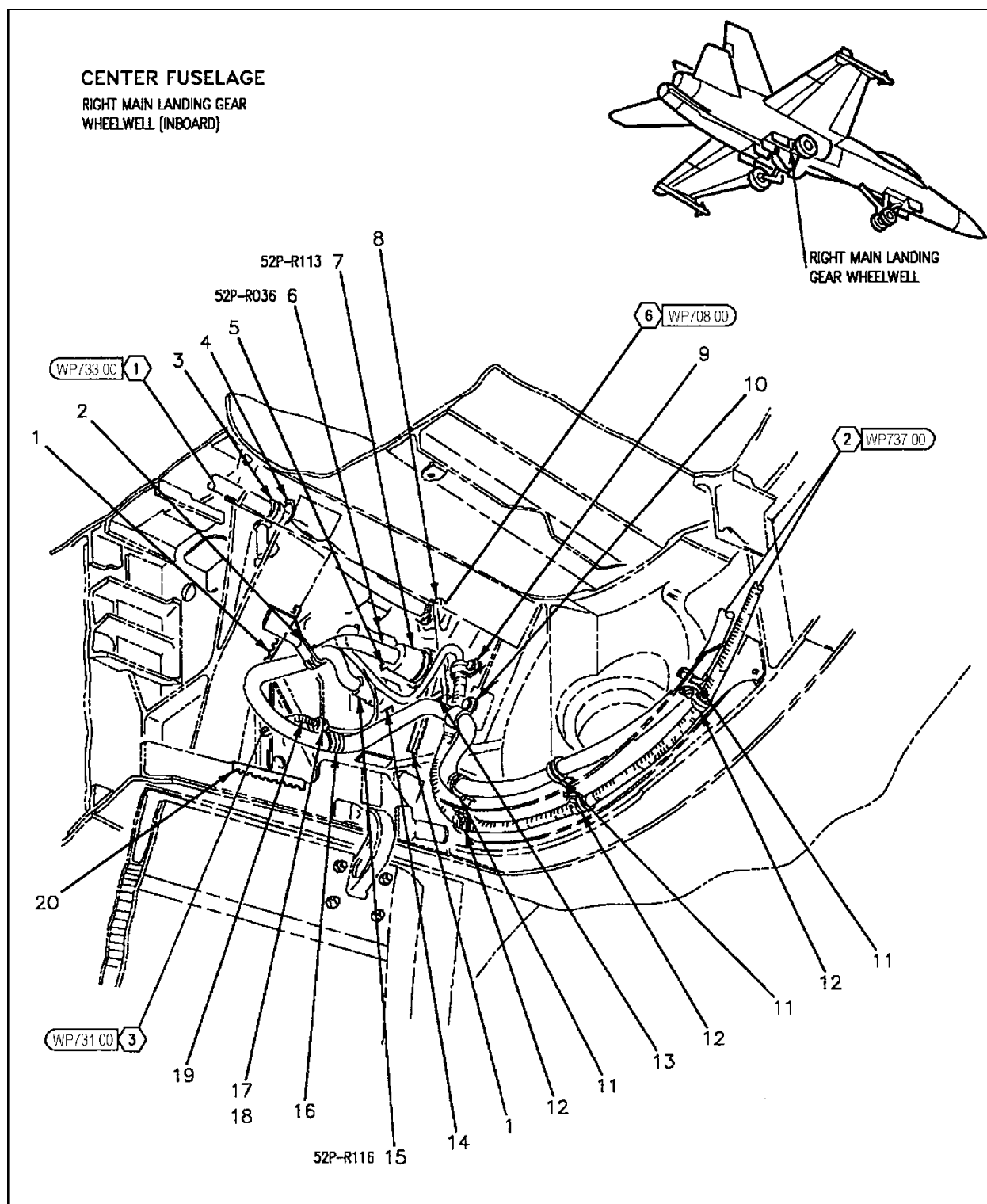

FIGURE D-28. Example of a wiring bundle routing illustration.

MIL-STD-3001-1A(AS) w/CHANGE 1

APPENDIX D

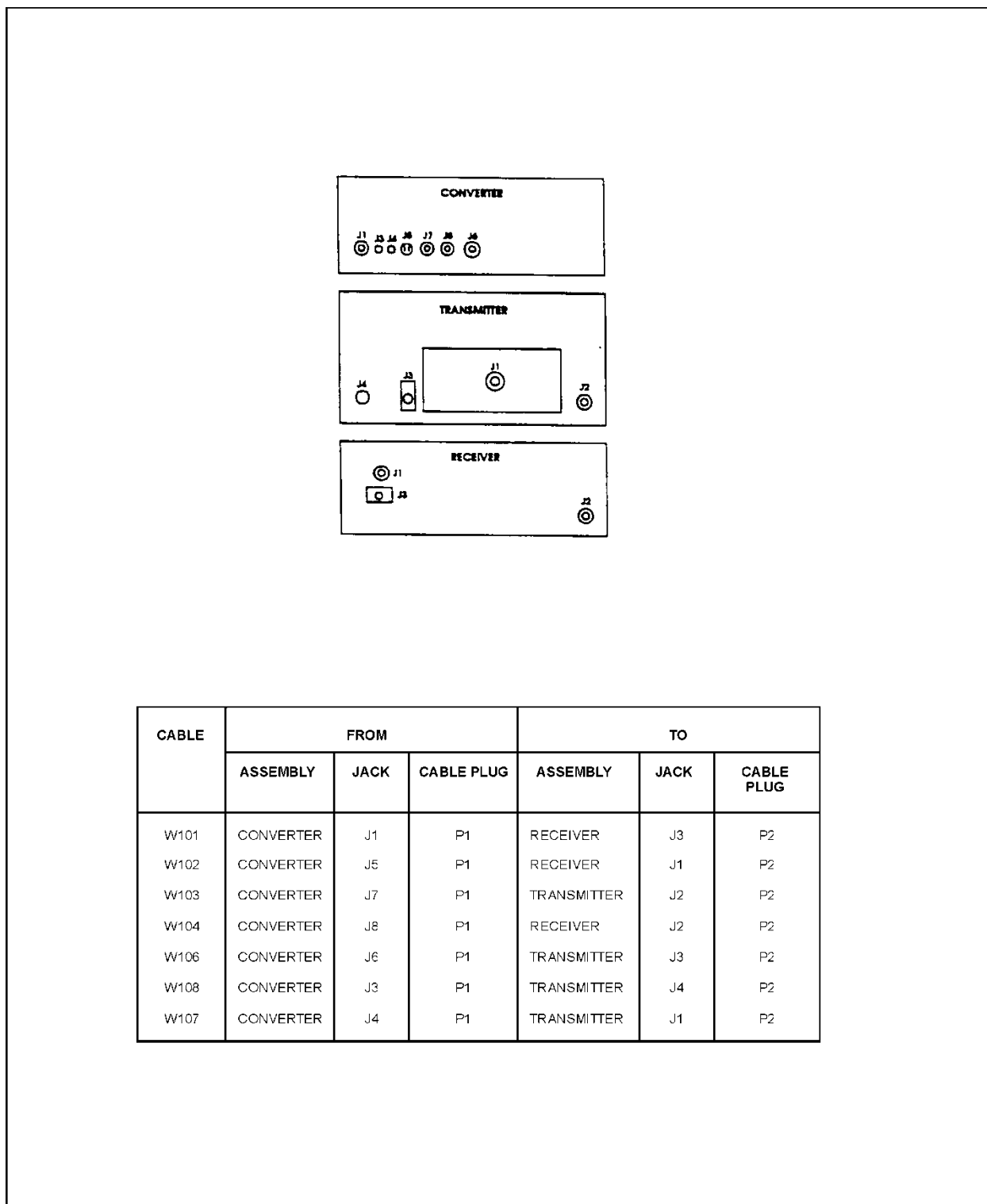

FIGURE D-29. Example of a cabling diagram with table.

MIL-STD-3001-1A(AS) w/CHANGE 1

APPENDIX D

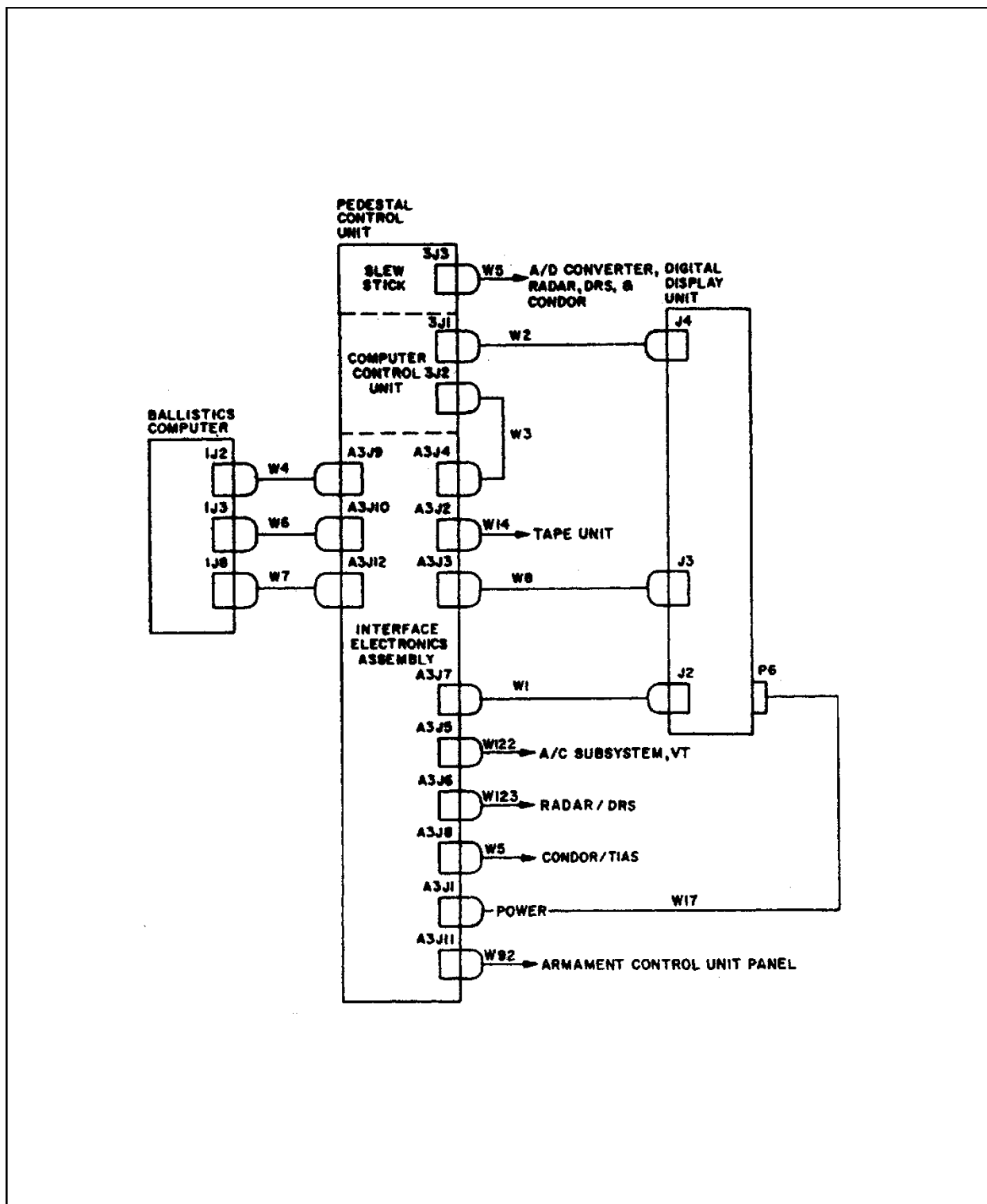

FIGURE D-30. Example of a cable interconnect diagram.

MIL-STD-3001-1A(AS) w/CHANGE 1

APPENDIX D

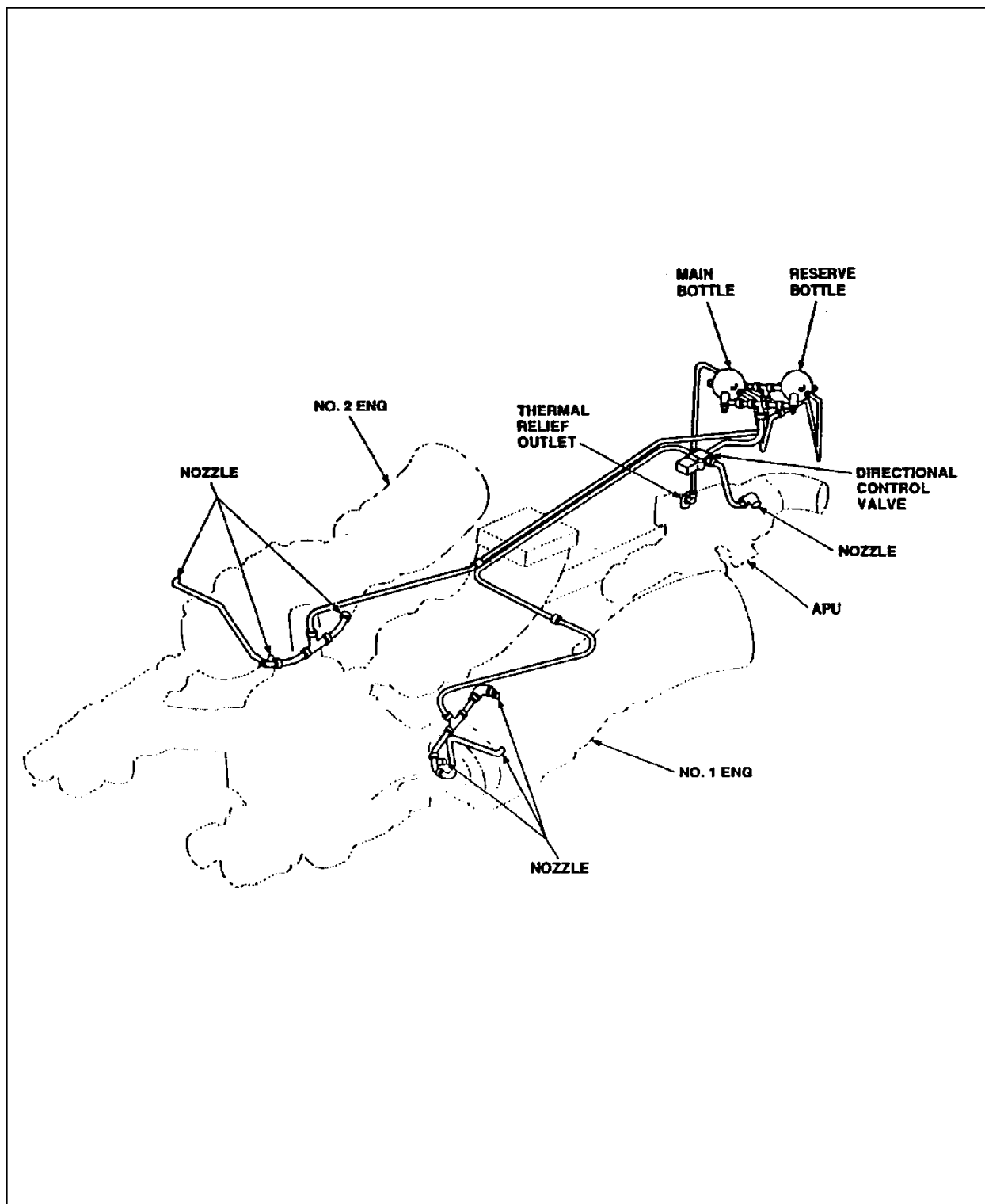

FIGURE D-31. Example of a piping diagram.

MIL-STD-3001-1A(AS) w/CHANGE 1

APPENDIX D

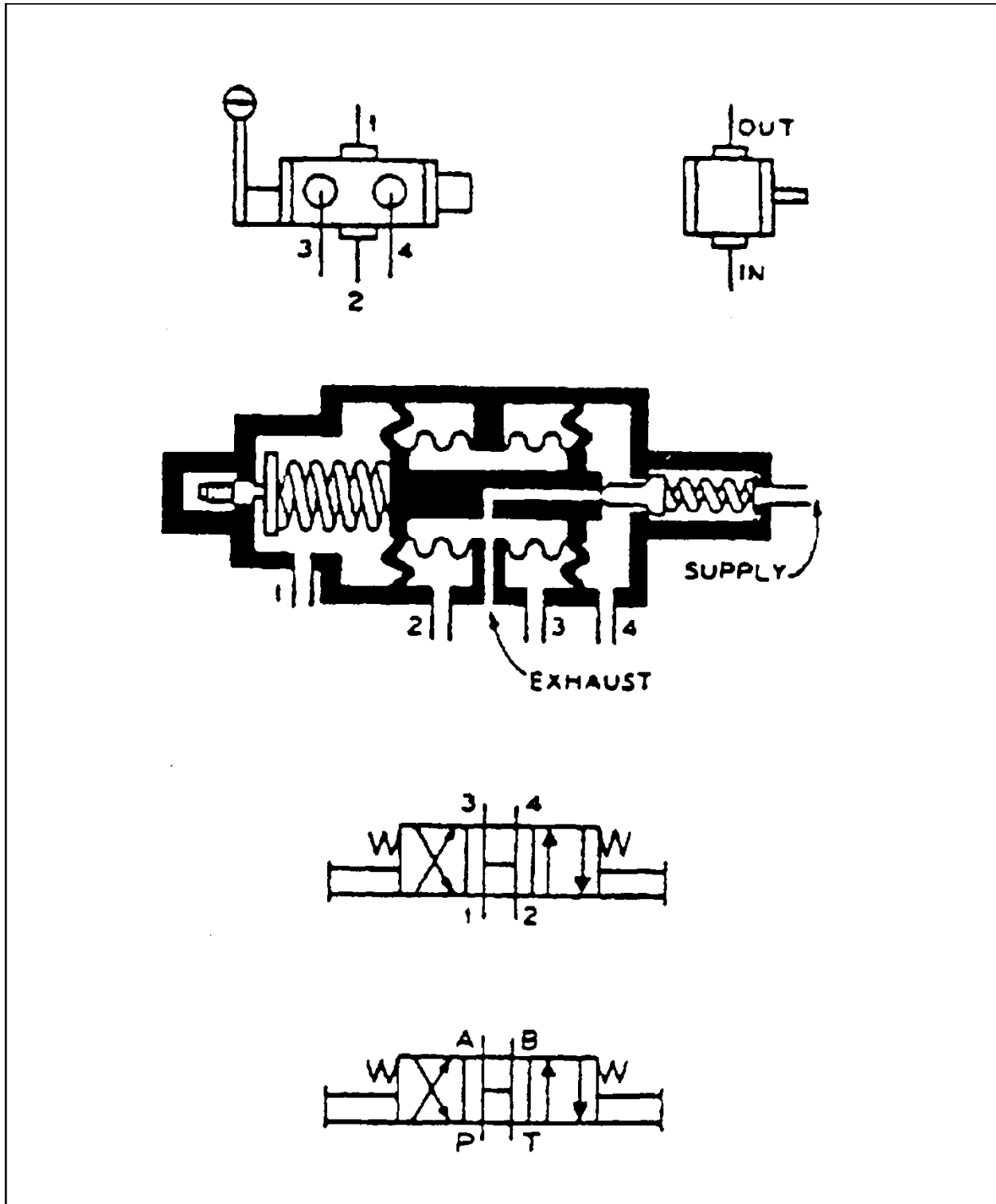

FIGURE D-32. Example of port identification.

MIL-STD-3001-1A(AS) w/CHANGE 1

APPENDIX D

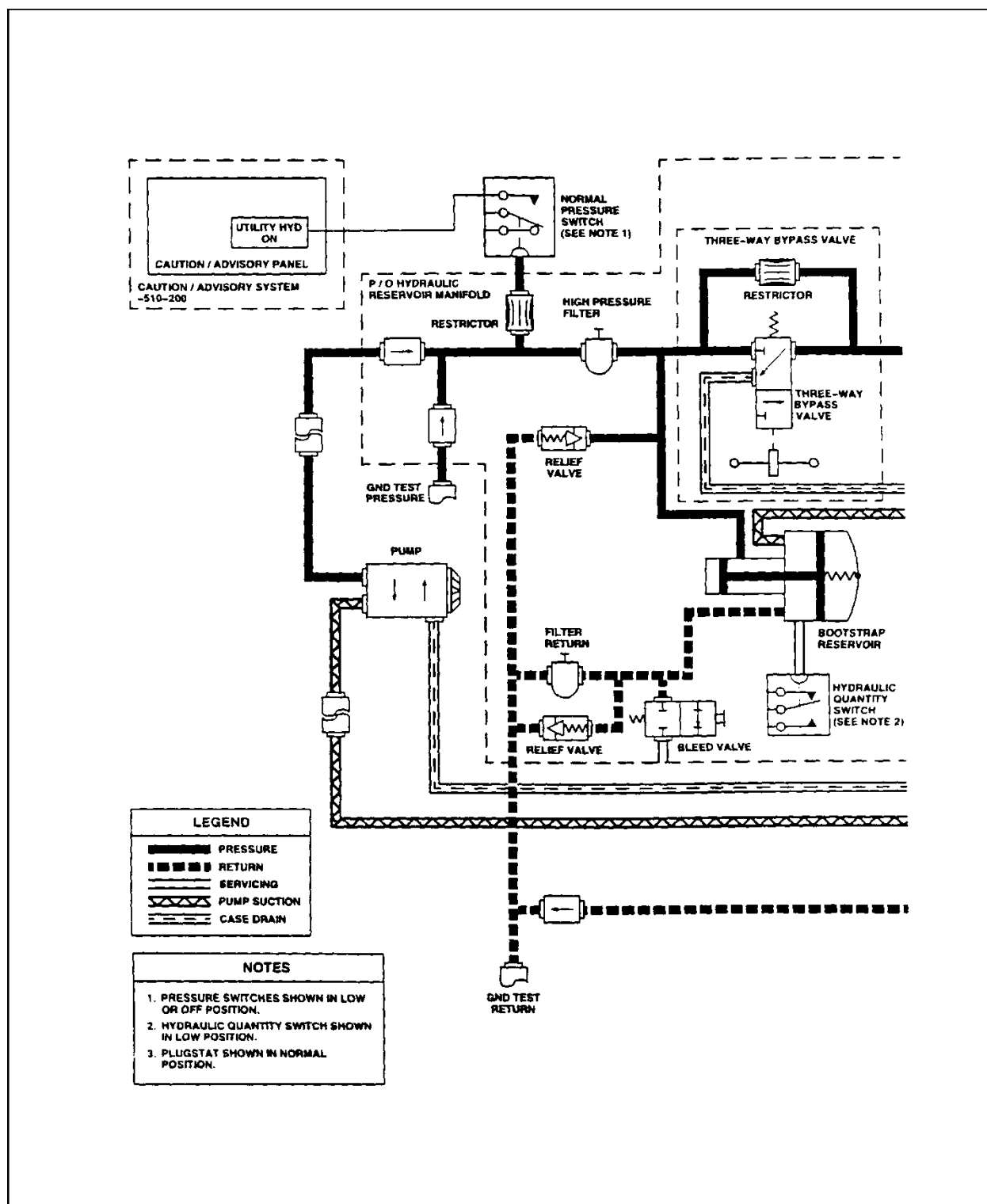

FIGURE D-33. Example of pattern codes.

MIL-STD-3001-1A(AS) w/CHANGE 1

CONCLUDING MATERIAL

Custodian:
Navy - AS

Preparing activity:
Navy - AS
(Project TMSS-2016-019)

NOTE: The activity listed above was interested in this document as of the date of this document. Since organizations and responsibilities can change, you should verify the currency of the information above using the ASSIST Online database at <https://assist.dla.mil>.