

NOT MEASUREMENT
SENSITIVE

MIL-STD-3001-8(AS)
15 May 2001
SUPERSEDING
(See Section 6.)

DEPARTMENT OF DEFENSE STANDARD PRACTICE

DIGITAL TECHNICAL INFORMATION
FOR
MULTI-OUTPUT PRESENTATION
OF
TECHNICAL MANUALS

ILLUSTRATED PARTS BREAKDOWN (IPB)
(PART 8 OF 8 PARTS)



AMSC A7194

AREA TMSS

DISTRIBUTION STATEMENT A. Approved for public release; distribution is unlimited.

MIL-STD-3001-8(AS)

FOREWORD

1. This eight-part standard establishes the requirements needed to prepare digital technical information for multi-output presentation of NAVAIR work package Technical Manuals (TMs). The technical content and mandatory style and format requirements contained in this eight-part standard can be used to develop and assemble complete TMs for aircraft weapon systems, aeronautical equipment, airborne weapons/equipment, and support equipment work package technical manuals. The requirements in this Part are applicable for both paper and digitally displayed, page-oriented TMs.
2. MIL-STD-3001-8 is Part 8 of 8 Parts and is incomplete without Part 1. Part 8 establishes the technical content requirements for the preparation of a separate illustrated parts breakdown (IPB) for aircraft weapon systems, aeronautical equipment, airborne weapons/equipment, and support equipment. This data can be used to develop separate IPBs in a variety of output forms, including page-based screen presentations and page-based printed manuals.
3. MIL-STD-3001-1 contains general preparation requirements for the multi-output presentation of NAVAIR work package TMs. MIL-STD-3001-2 through MIL-STD-3001-8 contain specific functional technical content requirements for the preparation of all NAVAIR work package TMs and revisions. Parts 1 through 8 are identified below.

MIL-STD-3001-1	Preparation of Digital Technical Information for Multi-output Presentation of Technical Manuals.
MIL-STD-3001-2	Description, Principles of Operation, and Operation Data.
MIL-STD-3001-3	Testing and Troubleshooting Procedures.
MIL-STD-3001-4	Maintenance Information with IPB.
MIL-STD-3001-5	Aircraft Wiring Information.
MIL-STD-3001-6	Structural Repair Information.
MIL-STD-3001-7	Periodic Maintenance Requirements.
MIL-STD-3001-8	Separate Illustrated Parts Breakdown (IPB).
4. MIL-HDBK-3001, Guide to the General Style and Format of U.S. Navy Work Package Technical Manuals, complements this eight-part standard. MIL-HDBK-3001 provides Navy-preferred, nonmandatory style and format requirements for the preparation of page-oriented, scrollable and frame-based work package technical manuals.
5. Beneficial comments (recommendations, additions, deletions) and any pertinent data which may be of use in improving this document should be addressed to: Commander, Naval Air Warfare Center Aircraft Division, Code 414100B120-3, Highway 547, Lakehurst, NJ 08733-5100 by using the Standardization Document Improvement Proposal (DD Form 1426) appearing at the end of this document or by letter.

MIL-STD-3001-8(AS)

CONTENTS

<u>PARAGRAPH</u>	<u>PAGE</u>
FOREWORD	ii
1. SCOPE	1
1.1 Scope	1
2. APPLICABLE DOCUMENTS	1
3. DEFINITIONS	1
4. GENERAL REQUIREMENTS	1
4.1 General.....	1
4.2 Maintenance level applicability.....	1
4.3 Selective application and tailoring.....	1
4.4 Preparation of digital data for electronic delivery	1
4.4.1 Use of the DTDs	1
4.5 Technical content.....	1
4.5.1 Style and format requirements.....	2
4.6 Standard tables and lists.....	2
5. DETAILED REQUIREMENTS	2
5.1 Preparation of separate illustrated parts breakdown (IPB).....	2
5.2 Front matter.....	2
5.2.1 Title page <titlepg>.....	2
5.2.2 Numerical index of effective figures/pages (A page) <niepage>.....	4
5.2.3 Technical publication deficiency reports (TPDR) incorporated pages <tpdrpg>.....	4
5.2.3.1 Development of the technical publication deficiency reports incorporated.....	5
5.2.4 Introduction for separate IPB manuals <intro>.....	5
5.2.4.1 Title block <titleblk>	5
5.2.4.2 Short introduction for multi-volume sets.....	7
5.3 Alphabetical index <alphaindx>.....	7
5.3.1 Development of the alphabetical index.....	7
5.3.2 Multi-volume set alphabetical index	8
5.4 Numerical index of part numbers <partnoindx>.....	8
5.4.1 Development of the numerical index of part numbers.....	9
5.5 Numerical index of reference designations <refdesindx>	10
5.5.1 Development of the numerical index of reference designations	10
5.6 Group assembly parts list (GAPL) and associated IPB figures.....	11
5.6.1 IPB figure illustrations <figure>	11
5.6.2 IPB GAPL <gapl>	11
5.6.2.1 Index numbers <indexno>.....	11
5.6.2.1.1 Index numbers for attaching parts	11
5.6.2.2 Part numbers <gaplpartno>.....	12
5.6.2.3 Description.....	15
5.6.2.4 Units per assembly <units>.....	19
5.6.2.5 Usable on code <useoncode>.....	20
5.6.2.6 SM&R code <smrcode>.....	21
5.6.2.7 Work unit code (WUC) <wuc>.....	21
5.6.2.8 Detailed IPB technical content requirements.....	21
5.6.2.8.1 Nuclear hardness critical items (HCI), (CSI) or (OCI).....	21

MIL-STD-3001-8(AS)

CONTENTS

<u>PARAGRAPH</u>	<u>PAGE</u>
5.6.2.8.2 Electrostatic discharge (ESD) sensitive parts.....	21
5.6.2.8.3 Index numbers on illustrations	21
5.6.2.8.4 Attaching parts on illustrations.....	21
5.6.2.8.5 Indexing assemblies.....	21
5.6.2.8.6 Items not having a logical maintenance sequence	21
5.6.2.8.7 Component boards	22
5.6.2.8.8 Polarity identification	22
5.6.2.8.9 Reference designations <refdes>.....	22
6. NOTES	22

FIGURES

FIGURE 1. Example of a numerical index of effective figures/pages.....	23
FIGURE 2. Example of alphabetical index.	24
FIGURE 3. Example of a numerical index of part numbers.....	25
FIGURE 3. Example of a numerical index of part numbers - continued.	26
FIGURE 4. Example of a numerical index of reference designations.....	27
FIGURE 4. Example of a numerical index of reference designations - continued.	28
FIGURE 5. Example of IPB figure - separate IPB manual.	29
FIGURE 5. Example of IPB figure - separate IPB manual - continued.....	30
FIGURE 6. Example of IPB GAPL - separate IPB manual.	31
FIGURE 6. Example of IPB GAPL - separate IPB manual - continued.....	32
FIGURE 7. Example of parts kit.....	33

MIL-STD-3001-8(AS)

1. SCOPE.

1.1 Scope. This part of the standard establishes the technical content requirements for the preparation of separate page-based illustrated parts breakdowns (IPBs) manuals for aircraft weapon systems, aeronautical equipment, airborne weapons/equipment, and support equipment. This data can be used to develop separate IPB manuals in a variety of output forms, including page-based, screen presentations and page-based, printed manuals.

2. APPLICABLE DOCUMENTS.

The applicable documents in section 2 of MIL-STD-3001-1 apply to this Part.

3. DEFINITIONS.

The definitions in section 3 of MIL-STD-3001-1 apply to this Part.

4. GENERAL REQUIREMENTS.

4.1 General. When specified by the requiring activity, a separate IPB shall be developed for the aircraft weapon system, aeronautical equipment, airborne weapons/equipment or support equipment.

4.2 Maintenance level applicability. Requirements contained in this standard are applicable to all types and maintenance levels of TMs unless specifically noted in bold and in parentheses (i.e., **Support Equipment Manuals only, Depot Level only**, etc.).

4.3 Selective application and tailoring. This Part contains some requirements that may not be applicable to the preparation of all technical manuals. Selective application and tailoring of requirements contained in this Part shall be accomplished through the use of the Technical Manual Content Selection Matrixes contained in MIL-STD-3001-1, Appendix A. The applicability of some requirements is also designated by one of the following statements: unless specified otherwise by the requiring activity or as/when specified by the requiring activity.

4.4 Preparation of digital data for electronic delivery. Technical manual data delivered digitally in accordance with this standard shall be SGML-tagged and assembled using the modular Document Type Definition (DTD). Refer to MIL-STD-3001-1 for information on obtaining or accessing this modular DTD. SGML tags used in the modular DTD are noted throughout the text of this standard in bracketed, bold characters (i.e., **<titlepg>**) as a convenience for the TM author and to denote the appropriate tag to be used for this specific information when developing a document instance.

4.4.1 Use of the DTDs. The modular DTDs referenced in this Part interpret the technical content and structure for the functional requirements contained in this Part and are mandatory for use.

4.5 Technical content. Technical content requirements contained in this Part are considered mandatory and are intended for compliance. The content structure for the technical data being developed shall conform to the associated modular Document Type Definition (DTD) for separate Illustrated Parts Breakdowns (IPBs).

MIL-STD-3001-8(AS)

4.5.1 Style and format requirements. Refer to MIL-STD-3001-1, Appendix B for the mandatory style and format requirements for the preparation of page-oriented NAVAIR IPB TMs. MIL-HDBK-3001 provides Navy-preferred, nonmandatory style and format requirements for the preparation of page-oriented IPB technical manuals.

4.6 Standard tables and lists. Standard tables and lists are noted throughout the text of this standard in bold and in parentheses (i.e., (**standard table**), (**standard list**)). The table and list head titles and structure of these standard tables and lists shall have no deviations.

5. DETAILED REQUIREMENTS.

5.1 Preparation of separate illustrated parts breakdown (IPB). IPB data is used for maintenance support, requisition, storage, authority for use and identification of parts. A separate IPB manual shall be arranged as follows:

Front matter

Alphabetical index

Numerical index of part numbers

Numerical index of reference designations

Group assembly parts list (GAPL) and associated IPB figures.

5.2 Front matter. The front matter identifies the manual and includes information on what is included in the manual, where the information is located, and how to locate the technical information within the manual. Front matter and supporting information consist of the following items:

- a. Title page.
- b. Numerical index of effective figures/pages.
- c. TPDR page.
- d. Introduction.

5.2.1 Title page <titlepg>. A title page shall be prepared for all IPB manuals. The format of the title page is shown in MIL-STD-3001-1, Appendix B, figure B-1. The title page shall contain the following content information:

a. Publication number <tmidno>. The publication number assigned by the requiring activity shall be placed in the extreme upper left corner of the page. Each manual or volume thereof shall have a separate publication number assigned. If the manual is to be used jointly with other services, the requiring activity's publication number shall be placed above the other services' publication number(s).

b. Former publication number <pretmidno>. If the manual has been renumbered, the former publication number will appear below the new number and shall be preceded by the word "Formerly." At the next revision, only the new number shall appear.

MIL-STD-3001-8(AS)

c. Publication date <pubdate>. The publication date or revision date shall be placed in the upper left corner, below the publication number, joint usage number, and/or former publication number.

d. Change number <chgnum> and date <chgdate>. The change number and date for a pickup revision, if applicable, shall be placed in the upper left corner, below the publication date.

e. Type of document. The words "TECHNICAL MANUAL" shall be centered on the page.

f. Publication title<prtitle>. The publication title shall consist of the level of maintenance, the manual type, and the end item nomenclature:

(1) Level of maintenance <maintlvl>. The level(s) of maintenance coverage, such as "ORGANIZATIONAL MAINTENANCE."

(2) Manual type <manualtype>. If applicable, the manual type, such as "PRINCIPLES OF OPERATION," that is contained in the manual.

(3) End item nomenclature <sysnomen>. The end item nomenclature, such as the system, subsystem, or equipment (including AN type designation), shall be centered below the type of manual. When applicable, the model(s), and part number(s) shall be placed below the nomenclature.

(a) Multiple AN type designations. When the manual covers more than one AN type designation, each AN type designation shall be placed sequentially below the end item nomenclature followed by the applicable model and/or part number, e.g.,

AN/ARC-300(V)1, MODEL NUMBER MXD 507, PART NUMBER 123456-801

AN/ARC-300(V)2, MODEL NUMBER MXD 508, PART NUMBER 123456-802

or

RT-2099/ARC-300 (V), P/N 45678-801

RT-2099/ARC-300 (V), P/N 45678-802.

If applicable, an effectivity statement reflecting tail numbers, BuNos, model numbers, serial numbers, etc., covered by the TM shall be added immediately following the end item nomenclature.

(b) System coverage of multiple end items <syscomp>. When a single manual is authorized to cover a system, all system components shall be listed below the system nomenclature. The caption "Consisting of" shall be centered below the system data. The system components shall be listed below the caption "Consisting of" in the same manner as the system data. AN type designations may be listed on the same line as the model and part numbers.

g. Supersedure notice <super>. When a manual is revised, a supersedure notice shall be placed below the end item nomenclature, designator, model, and/or part number(s). The notice shall always include the publication number and date, and, if applicable, the revision number and date of the superseded manual. For example: "This manual supersedes AE-172AA-720-100, dated 15 November 1978." If a classified manual is being revised, the supersedure notice shall add the following statement, "which shall be destroyed in accordance with applicable security regulations."

MIL-STD-3001-8(AS)

h. Cross-reference notices <suppl>. When required, a cross-reference notice to supplements shall be placed below the supersedure notice or publication title.

i. Continuation notice <continue>. When a manual must be divided, a continuation notice shall appear on the title page of each volume below the supersedure notice or publication title. The title page of each volume shall contain a statement that the applicable volume is incomplete without the other volume(s) of the set.

j. Interim rapid action change (IRAC) <irac>. A statement reflecting that IRACs have been incorporated into the TM.

k. Distribution statement <distrib>. A distribution statement shall be placed above the authority notice. The distribution statement shall read as follows:

DISTRIBUTION STATEMENT C. Distribution authorized to U.S. Government agencies and their contractors to protect publications required for official use or for administrative or operational purposes only, determined on 1 June 1983. Other requests for this document shall be referred to Commanding Officer, Naval Air Technical Data and Engineering Service Command, Naval Air Station North Island, P.O. Box 357031, Building 90 Distribution, San Diego, CA 92135-7031.

(1) Determination date. The determination date shall be the date of the publication (basic or revision date, as applicable) when the distribution statement is applied.

(2) Changed distribution statement. If the distribution statement is changed, the determination date will be the date of issue that effected the change.

l. Destruction notice <destr>. The destruction notice shall be placed directly below the distribution statement and shall read as follows:

(1) For classified manuals:

DESTRUCTION NOTICE - For classified documents follow the procedures in DoD 5220.22M, Industrial Security Manual, Section 11-19 or DoD 5200.1R, Information Security Program Regulation, Chapter IX (Chapter 17 of OPNAVINST 5510.1).

(2) For unclassified manuals:

DESTRUCTION NOTICE - For unclassified, limited documents, destroy by any method that will prevent disclosure of contents or reconstruction of the document.

m. Authority notice <authnote>. The authority notice shall be centered directly below the destruction notice.

5.2.2 Numerical index of effective figures/pages (A page) <niepage>. A numerical index of effective pages shall be included for all manuals. The "A" page shall back up the title page and shall be prepared as shown in figure 1.

5.2.3 Technical publication deficiency reports (TPDR) incorporated pages <tpdrpg>. A list of TPDRs incorporated shall be prepared for all revised manuals (see MIL-STD-3001-1, Appendix B, figure B-10). The TPDR list shall begin on the first right-hand page following the A-page (numerical index of effective

MIL-STD-3001-8(AS)

figures/pages). In multi-volume sets, each volume shall contain a list of technical publication deficiency reports incorporated for the volume.

5.2.3.1 Development of the technical publication deficiency reports incorporated. The list (**standard list**) shall reflect the data incorporated in the technical manual resulting from valid technical publication deficiency reports (TPDRs). The "Identification No." column shall indicate the reporting activity and its TPDR file number. The "Location" column shall indicate the work package (WP)/page No. (pg)/paragraph No. (p)/figure No. (F)/table No. (T) as appropriate, identifying the location in the manual where the data has been incorporated. The list shall reflect the data that has been incorporated in that particular issue. The list shall not be cumulative. The TPDR page shall be prepared at the first formal revision to the manual. If no TPDRs are to be incorporated, the word "None" shall be entered.

5.2.4 Introduction for separate IPB manuals <intro>. All separate IPB manuals and all multi-volume IPB manuals shall have an introduction. The second and subsequent manuals of a multi-volume set shall have a short introduction. The introduction shall consist of the applicable requirements described in 5.2.4.1 and 5.2.4.2.

5.2.4.1 Title block <titleblk>. The title block (see MIL-STD-3001-1, Appendix B, figure B-17) shall contain the following data:

a. Title <wptitle> data. The title block shall contain the following title information.

(1) Maintenance levels <maintlvl>. The maintenance level(s) shall be stated, for example: "INTERMEDIATE AND DEPOT."

(2) WP general title <subject>. The title shall describe the general subject, for example: "INTRODUCTION."

(3) End item nomenclature <sysnomen>. The end item nomenclature such as the system, subsystem, or equipment (including AN type designation), shall follow the general title. When applicable, the model(s), and part number(s) shall be placed below the nomenclature. When the introduction covers more than one model and/or part number, all models and/or part numbers shall be listed.

b. Purpose and scope <intropara>. The purpose and scope of the manual, including the subject matter being covered.

c. Description and designated nomenclature <intropara>. The designated nomenclature and a brief description of the end item. The introduction shall not include an illustration of the equipment.

d. Joint Service requirements <intropara>. Complete identifying information is required if the IPB is to be used by another service that designates the end item by its own type, model or serial numbers.

e. Technical directives <intropara>. An explanation and purpose of technical directives followed by an historical record of technical directives.

f. Requisitioning and automatic distribution of NAVAIR technical publications <intropara>. The following statement relative to requisitioning and automatic distribution of NAVAIR technical publications shall be included:

MIL-STD-3001-8(AS)

"Procedures to be used by naval activities and other Department of Defense activities requiring NAVAIR technical manuals are defined in NAVAIR 00-25-100."

Additional information such as how to automatically receive future revisions and to order replacement or additional copies shall also be included.

g. Abbreviations, symbols, new and unusual terms <intropara>. An explanation of the abbreviations, symbols, and new and unusual terms used in the WPs and not included in OPNAVINST 4790.2 (e.g., LOX, QEC, MAG, HCP, HCI, ESD, etc.) shall be included.

h. Nuclear survivability requirements <intropara>.

(1) The introduction shall include an explanation of the [HCI] symbol's usage and method of highlighting and other pertinent information as necessary to emphasize uniqueness of Hardness Critical Items (HCI).

(2) The introduction shall include a caution statement explaining that the symbol establishes the requirement that all paragraphs and processes/steps in the WPs and items in the GAPL identified by the symbol must be followed as written to ensure nuclear hardness is not degraded.

i. Electrostatic discharge (ESD) sensitive parts <intropara>.

(1) The introduction shall include an explanation of the [ESD] symbol's usage and method of highlighting and other pertinent information as necessary to emphasize uniqueness of ESD sensitive components.

(2) The introduction shall include a caution statement explaining that the symbol establishes the requirement that all paragraphs and processes/steps in the maintenance WPs and items in the IPB identified by the symbol must be followed as written to ensure ESD sensitive components are not degraded. The caution shall reference OPNAVINST 4790.2 for standard maintenance practices and handling procedures and precautions.

j. Technical publications deficiency report (TPDR) <intropara>. An explanation and purpose of the TPDR.

k. Numerical indexes of part numbers and reference designations <intropara>. An explanation, including how to use the numerical index of part numbers and reference designations.

l. Source, maintenance, and recoverability (SM&R) codes <intropara>. An explanation of SM&R codes, with an appropriate supporting illustration, shall be included. Reference to the specific issue of the NAVAIR instruction to which the end item was provisioned shall be made. Explain the method of provisioning used for multiple application of identical parts and the specific impact on the listed SM&R codes (e.g., first occurrence coding). In addition, the NAVICP P2300 series publications shall be cited as the source for the most current SM&R code listed in an IPB and if different than the manual, the manual requires an update to reflect any related maintenance instructions.

m. Part Number column. Explain the meaning of a dash (-) or "COML."

n. Description column. Explain the following entries, if applicable:

(1) Indention to show relationship, numbers and leaders (periods).

MIL-STD-3001-8(AS)

(2) Preceding symbols (HCI or ESD).

(3) Manufacturer's code.

(4) Any make-from parts shall include specific part number and source for the source stock item.

(a) Appearance in listing, including suppression of the Government and/or prime contractor's codes. When the prime contractor's code is suppressed, the code must be identified in the introduction.

(b) Reference shall be made to the H-4/H-8 catalog series for detailed information.

(5) Conditional acronym or abbreviation (LOX/QEC/MAG).

(6) Method of listing attaching parts.

(7) Parts kits. Method of listing, including indention.

(8) Amplifying information.

o. Units per assembly column. Explain any unusual entries.

p. Useable on code column. Application and Alternate/Equivalent/Redesigned parts.

5.2.4.2 Short introduction for multi-volume sets. The introduction for the second and subsequent volumes of a multi-volume set should be limited to a title block (5.2.4.1 a.), purpose and scope (5.2.4.1 b.) and a reference to the comprehensive introduction provided in the first volume of the set.

5.3 Alphabetical index <alphaindx>. The alphabetical index (figure 2) should begin on the first right-hand page following the front matter. The primary purpose of this index is to provide access to the figure containing the required coverage. The alphabetical index shall include the following:

a. Alphabetical index title block. The first page of the index shall include a title block. The title block shall include the title "ALPHABETICAL INDEX" and the end item nomenclature should be centered below the title.

b. Column heads. The column heads "Title" and "Figure Number" or "Publication/Figure Number" should be placed below the title block.

(1) Main entries. Main entries in the "title" column should begin at the left margin.

(2) Subordinate (cross-reference) entries. Subordinate entries listed below a main entry shall be indented.

5.3.1 Development of the alphabetical index. The primary consideration in the development of the alphabetical index should be the accessibility of the data. The primary purpose of this index is to provide access, by item nomenclature, to the figure containing the required coverage. The following guidelines apply:

MIL-STD-3001-8(AS)

a. As a minimum, the index should list every figure title that appears in the manual or volume. Cross-indexing and duplication of detailed figure titles under the next higher assembly figure title should be included.

(1) Maintenance level(s). The maintenance level entries are not required, unless the data is separated into two or more figures by maintenance level.

(2) Figure's end item nomenclature. The figure end item's nomenclature should be identical with the figure title, except for arrangement of wording.

(a) Nomenclature for the assembly/subassembly should be arranged with the noun name preceding the modifiers; e.g., "Power Driven Rotary Vacuum Pump" should be listed as "Pump, Rotary, Vacuum Power Driven."

(b) Nomenclature should also be listed under significant modifiers as functional task or element cross-reference entries, e.g., "Vacuum Pump, Rotary, Power Driven."

(c) "AN" nomenclature should not be used as a main entry, but should be used as a subordinate (cross-reference entry); e.g., "Mount, Antenna, Coupler, UHF, MT-1995/A, (34A1)" should be listed as "MT-1995/A UHF Antenna Coupler Mount (34A1)."

(d) End Item's Reference Designation should not be used as a main entry, but should be listed following applicable entries to improve access to data. This is extremely critical when more than one item has similar nomenclature.

(3) Effectivity notice. The effectivity should be listed as a subordinate entry when the same basic item is covered in more than one effectivity.

c. System and subsystems. System and subsystem entries should be obtained from the Figure titles. System names should be listed as main entries. Subsystems should be listed as subordinate entries for the applicable system. Subsystem names should be listed as main entries when listed in the figure title.

5.3.2 Multi-volume set alphabetical index. The alphabetical index should begin on the first right-hand page following the front matter. The primary purpose of this index is to provide access to the alphabetical index of the manual containing the required coverage. The alphabetical index should be prepared in accordance with 5.3 and 5.3.1, except as follows:

a. Column heads. The column heads "SYSTEM/SUBSYSTEM" and "PUBLICATION NUMBER" should be placed below the title block.

(1) Main entries in the system/subsystem column should begin at the left margin.

(2) Subordinate entries listed below a main entry shall be indented.

5.4 Numerical index of part numbers <partnoindx>. All separate IPB manuals should have a numerical index of part numbers (**standard list**). The index (figure 3) should begin on the first right-hand page following the Introduction. The primary purpose of this index is to provide direct access to the specific manual, figure, and index number related to a specific part number. The numerical index of part numbers shall consist of the following:

MIL-STD-3001-8(AS)

a. Title block. The first page of the index shall include a title block. The title block shall include the title "NUMERICAL INDEX OF PART NUMBERS," and the end item nomenclature should be centered below the title.

b. Column heads. The column heads "PART NUMBER" and "FIGURE/INDEX NUMBER" or "PUBLICATION/FIGURE/INDEX NUMBER" should be placed below the title block.

5.4.1 Development of the numerical index of part numbers. The numerical index should be prepared as follows:

a. Part number column. The part number column is used to establish the content. All part numbers listed in the GAPL part number column of every IPB figure contained in the manual should be listed. Superseded parts that have continued application should be listed. Government standard and attaching parts may be listed in the index only for their first appearance in the manual to reduce unnecessary redundant entries in the index. Part numbers for items listed more than once in the manual (except for Government standard and attaching parts) should have entries for each listing.

(1) Manual listing development. Part numbers should be listed in alphanumeric sequence as follows:

(a) First position of the part number in order of precedence; the letters A through Z, the numerals zero through nine.

(b) Second and succeeding positions of the part number in order of precedence, from left to right; space (blank position), diagonal (/), point (.), dash (-), letters A through Z, and numerals zero through nine.

(c) Items without part numbers (listed with a dash (-) in the GAPL part number column) should be listed alphabetically, using the identifying noun in lieu of a part number.

(2) Computer listing development.

(a) Part numbers should be listed in normal computer (ASCII code) ascending numeric/alpha part number sequence, and

(b) Items without part numbers (listed with a dash (-) or "COML" in the GAPL part number column) should be listed alphabetically, using the identifying noun in lieu of a part number.

b. Figure/index number column. The diagonal line (/) is used to separate the entries. When more than one entry is required for a part number, the entries should be listed in the following order of precedence: figure number and index number. When the entry is for the IPB figure's end item, the index number should be left blank. Each entry should list the figure number first, followed by a diagonal line, and the index number, e.g., "F0041-00/17."

c. Publication/figure/index number column (multi-volume TMs only). The publication number should be added to the figure and index number listing required by b, above. A sufficient portion of the publication number of the manual/volume in which each part number listed appears should be identified. For example, if the publication number of the first manual is A1-F18AA-110-100 and the second manual is numbered A1-F18AA-120-100, only the numbers 110-100 and 120-100 would be listed. If the first volume is numbered A1-610AA-IMM-010 and the second volume is numbered A1-610AA-IMM-020, only the numbers 010 and 020 would be listed. The method of identification should be explained in the

MIL-STD-3001-8(AS)

applicable introduction. Each entry should list the publication number first, followed by a diagonal line, the figure number second, followed by a diagonal line, and the index number, e.g., "Publication Number/Figure Number/Index Number (110-100/F0041-00/17)."

5.5 Numerical index of reference designations <refdesindx>. All manuals containing any reference designations should have a numerical index of reference designations (**standard list**). The index (figure 4) should begin on the first right-hand page following the numerical index of part numbers. The primary purpose of this index is to provide direct access to the specific manual, figure, and index number related to a specific reference designation. The numerical index of reference designations shall consist of the following:

a. Title block. The first page of the index shall include a title block. The title block shall include the title "NUMERICAL INDEX OF "REFERENCE DESIGNATIONS" and the end item nomenclature should be centered below the title.

b. Column heads. The column heads "REF DES" and "FIGURE/INDEX NUMBER" or "PUBLICATION/FIGURE/INDEX NUMBER" should be placed below the title block. The column head "USABLE ON CODE" may be added (see 5.6.2.5), if required. The column heads should be underlined.

5.5.1 Development of the numerical index of reference designations. The numerical index should be prepared as follows:

a. Ref des column. The reference designations column is used to establish the content. All reference designations identified in any IPB figure contained in the manual should be listed in reference designation sequence or in normal computer (ASCII code) ascending numeric/alpha, reference designation sequence, as follows:

(1) Multiple identical assemblies (same reference designations). When multiple reference designations apply to the same IPB figure (e.g., circuit card assembly), all detail part reference designations should be listed in the first appearance in the manual.

(a) Second and subsequent items may reference the first item to reduce unnecessary redundant entries in the index.

(b) The second and subsequent reference designations should reference the end item breakdown figure and reference first related item, e.g., "BDKN same as A3" or "See A3 for BDKN."

(2) Multiple end items. When more than one unit is covered by one manual, a unit reference designation must be assigned or the same reference designation may apply to subassemblies of different end items.

(3) Effectivity difference. When a reference designation applies to more than one IPB figure (e.g., Effectivity difference), a "USABLE ON CODE" may be added to the index. An explanation of the "USABLE ON CODE" application and usage should be added to the introduction.

b. Figure/index number column. The diagonal line (/) is used to separate the entries. When more than one entry is required for a reference designation, they should be listed in the following order of precedence: figure number and index number. When the entry is for the IPB figure's end item, the index number should be left blank. Each entry should list the figure number first, followed by a diagonal line, and the index number, e.g., "F0041-00/17."

MIL-STD-3001-8(AS)

c. Publication/figure/index number column (multi-volume TMs only). The publication number should be added to the figure and index number listing required by b, above. A sufficient portion of the publication number of the manual/volume in which each part number listed appears should be identified. For example, if the publication number of the first manual is A1-F18AA-110-100 and the second manual is numbered A1-F18AA-120-100, only the numbers 110-100 and 120-100 would be listed. If the first volume is numbered A1-610AA-IMM-010 and the second volume is numbered A1-610AA-IMM-020, only the numbers 010 and 020 would be listed. The method of identification should be explained in the applicable introduction. Each entry should list the publication number first, followed by a diagonal line, the figure number second, followed by a diagonal line, and the index number, e.g., "Publication Number/Figure Number/Index Number (110-100/F0041-00/17)."

d. Usable on code column. This column may be added to the index if required for clarify; refer to 5.5.1a(3). When added, the column must be added to all index pages. When figure-specific usable on codes are used in different IPB figures, a modified coding must be used for this index.

5.6 Group assembly parts list (GAPL) and associated IPB figures. IPB data <plgrp> shall consist of a figure or a series of figures. Each figure should provide an illustration followed by the related Group Assembly Parts List (GAPL). A figure may contain more than one illustration. If more than one illustration is required, each illustration should precede the corresponding GAPL.

5.6.1 IPB figure illustrations <figure>. Each illustration (figure 5) shall adequately identify and locate repair parts. Multiple-view and multiple-sheet illustrations may be used. All illustrations shall precede the GAPL.

5.6.2 IPB GAPL <gapl>. The GAPL (**standard table**) shall be prepared as a tabular listing of all authorized repair parts for use in the performance of maintenance (see figure 6). Basic top-down breakdown sequence shall not be used in the development of the GAPL data, unless it matches the maintenance task to be performed. When usable on codes are needed to reflect multiple application of items in an individual GAPL, a master usable on code list shall be developed and placed at the bottom of the last tabular page of the GAPL (e.g., Effectivity, used to indicate that the item is applicable only after, or before, incorporation of a technical directive and/or specific serial number application). Refer to 5.6.2.5 for usable on code requirements. The GAPL entries are described in 5.6.2.1 through 5.6.2.7.

5.6.2.1 Index numbers <indexno>. The index numbers that appear in the associated illustrations shall appear as an entry under the heading "INDEX NO." in numerical sequence beginning with the number 1. Index numbers shall be assigned to all parts listed in the GAPL that have maintenance or supply significance, except as otherwise noted herein. Index numbers shall be first assigned to the GAPL and then applied to the IPB maintenance illustrations to maintain the proper sequence in the breakdown. If the same part number is listed more than once in the breakdown, it shall be assigned a different index number for each listing. No index number shall be assigned to an assembly when all detail parts are indexed, unless such assembly is also illustrated completely assembled on the illustration.

5.6.2.1.1 Index numbers for attaching parts.

a. Normally, index numbers shall be assigned to all attaching parts.

b. Fastening groups used at the same location (for example, a relay attached by multiple nuts, bolts, and washers) need not be individually illustrated or identified by index number, unless maintenance significant. When group callouts are used, they shall contain only one particular size, combination, or group of parts.

MIL-STD-3001-8(AS)

- (1) Each size, combination, or group of parts shall be listed separately.
- (2) If an identical part, appearing at several locations, is attached with different attaching parts, the part shall be indexed separately.
- (3) If more than one size or type of attaching part is used at different points on the part being attached, each size (with the pertinent attaching parts such as washer and nut) shall be given a separate index number so that the location of the different sizes and types may be readily identified in the illustration.

5.6.2.2 **Part numbers <gap>partno**. All end items, repair parts and items of support equipment provisioned for the applicable maintenance level support of the article shall be listed by part number. Part numbers assigned to the parts listed shall appear as an entry under the heading "PART NUMBER."

a. Parts not to be listed. The following parts shall not be listed:

- (1) Assembly detail parts that are permanently joined together. Parts that lose their identity by being welded or joined to other pieces as a permanent unit. This does not include riveted items provisioned for the applicable maintenance level of the manual.
- (2) Items made from bulk stock. Items made from (raw) bulk stock such as lockwire, bonding braid, upholstery cloth, and friction tape.
- (3) Structural items. Except for structural repair IPBs, structural items such as stringers, stiffeners, skin, doublers, and gussets, which serve no purpose in description of parts relationship or specification of significant procured parts, except when required to maintain next higher assembly identity or to identify items having maintenance significance.
- (4) Detail parts for consumable items. Details of items SM&R-coded for throw away.
- (5) Substitute item. A substitute item is an item which possesses such functional and physical characteristics as to be capable of being exchanged for another under specific conditions or for particular applications and without alteration of the item itself or those adjoining it. Degradation of equipment performance will result when substitute items are used. Substitute items shall not be listed, unless authorized by the requiring activity.

b. Items without part numbers.

- (1) Equipment(s) that have not been assigned part numbers, shall have the type or model number placed in the "PART NUMBER" entry. Either the type or model number shall be entered, for example, the one that corresponds to a national stock number (NSN) that has an assigned SM&R code.
- (2) If a vendor's part number is listed in the "PART NUMBER" entry, the type number, if applicable, shall be identified in the description.
- (3) Parts which have neither a part number nor a type and model number assigned shall have a dash (-) placed in the "PART NUMBER" entry.
- (4) Hardware procurable from normal commercial sources that does not have a part number assigned shall be identified by the abbreviation "COML" in the "PART NUMBER" entry. Identifying

MIL-STD-3001-8(AS)

information such as dimensions, material, and type shall be given after the description to enable replacement procurement from commercial sources.

c. Standard hardware provisioned for lowest level of maintenance usage.

(1) Standard hardware (such as bolts, studs, packing, hose clips, fasteners, clamps, resistors, capacitors, diodes, transistors, gaskets) which are manufactured to conform to the requirements of NAS, JAN, USAF, NAVAIR, AN or MS drawings shall be listed.

(2) When an item of standard hardware has been provisioned at the lowest level of support regardless of multilevel application, only the quantity of hardware required at the applicable level(s) of maintenance covered shall be listed and illustrated.

d. Oversize and undersize parts. When oversize or undersize parts are required and furnished and they are neither interchangeable with, nor within allowable production tolerances of, the standard size part, they shall be listed by the part number specified in the contract drawing specification.

e. Matched parts. When two or more parts that would normally be procured as separate items have been machined to fit as a matched set or lapped assembly, or have been matched electronically to meet circuit requirements, the set of items shall be assigned a separate part number.

f. Contractor standard parts. Contractor standard parts shall only be listed when the NSN is assigned to the contractor standard part.

g. Government standard parts. Government standard part numbers shall be listed in the "PART NUMBER" entry. The part number shall be complete, including prefixes and suffixes to the basic number. If more than one Government standard part number is listed on the contractor drawing specification for a single application, the preferred part number shall be listed.

h. Government standard items containing nonstandard detailed parts. Items covered by Government standard drawings, that contain repair parts that are not designated by Government detailed designed drawing numbers, shall be listed in organizational level manuals by the Government standard part number when the NSN is assigned to the Government standard item.

i. Altered or source-controlled items. If any Government standard or commercial item is altered, selected, or source controlled because of special fit, tolerance, weight, or reliability of performance, the part number of the activity responsible for the alteration, selection, or source control shall appear in the "PART NUMBER" entry. Repainting, reidentifying, or other insignificant operations shall not be considered alterations, selections, or source controls.

j. Similar assemblies. If right and left, top and bottom, front and rear, or other similar assemblies contain a majority of identical parts, the IPB for the similar assemblies shall be combined and identified in the GAPL.

k. Symmetrically opposite parts. Symmetrically opposite parts shall be listed separately and identified in accordance with the contract drawing specification.

l. Subcontractor or vendor items. Subcontractor or vendor items are defined as items that are used by the manufacturer of the item covered by the IPB exactly as produced by a subcontractor or vendor. Repainting, reidentifying, or other insignificant operations shall not be considered alterations, selections,

MIL-STD-3001-8(AS)

or source controls. When subcontractor or vendor items are assigned the NSN, the item part number shall be listed in the "PART NUMBER" entry.

m. Redesigned parts. If the design or material of a part is changed to the extent that interchangeability or physical or functional performance is affected, the new part number assigned in accordance with the contract drawing specification shall be listed. The original part shall be omitted if not authorized for continued use. If the original part has continued application, the application shall be indicated in the GAPL.

n. Selected electronic components. If a component board contains detail part(s) which can be replaced from a selection of components of different values, the illustration shall show one part. The GAPL shall list the basic part number without the specific value, for example: "RCO7GF---J." If the selection is to be made after test, a note shall appear after the description of the part, for example, "/Value determined at test/."

o. Alternate parts. An alternate part <altpart> is defined as a part that is used when a preferable part is not available. Alternate parts shall be listed below the preferred part when assigned an NSN. The specific relationship shall be identified in the GAPL "DESCRIPTION" and "USABLE ON CODE" entries.

p. Equivalent parts. An equivalent part <eqvpart> is defined as a part that is used interchangeably with one or more parts, none of which are preferable over the other. Equivalent parts shall be listed below the preferred part when assigned an NSN. The specific interchangeability shall be identified in the GAPL "USABLE ON CODE" entry.

q. Quick Engine Change Assembly (QECA). Following the breakdown of the quick engine change assembly, the part number and description of the Quick Engine Change Kit (QECK) shall be listed. All QECK parts shall be illustrated, indexed, and identified in the GAPL "DESCRIPTION" entry with the acronym "QEC."

r. Parts kits. When repair parts for the end item or for repairable units within the end item are to be supplied in the form of kits, a part number shall be assigned to each kit in accordance with contract drawing specification requirements (see figure 7).

(1) The kit(s) part numbers shall be placed last in the list of parts of the unit to which it applies and at the same indentation as the unit to which it applies. The kit components listed shall carry the appropriate kit SM&R code.

(2) Contents of the kit shall be listed at one indent below the kit description and shall not be assigned index numbers. Part number, description, quantity per kit, and SM&R code shall be included for each item in the kit.

(3) Lists of supplemental kits shall follow the list of original kits in the same manner as prescribed herein.

(4) Separate illustrations for kits shall not be prepared.

MIL-STD-3001-8(AS)

s. Markings.

(1) Decals, metalcalcs, and vinyl film markings, such as those that provide instructions, which require replacement or must be requisitioned separately, are considered to be parts. The identifying drawing number for each marking shall appear in the "PART NUMBER" entry.

(2) Locations of markings shall be illustrated; however, legible copy of the marking on the illustration shall not be required.

(3) A marking need not be listed or illustrated if:

(a) It is attached to a part or a nonrepairable assembly merely to identify it.

(b) The parts or nonrepairable assemblies are stocked, stored, and issued with the marking attached.

(c) The parts, not the marking, are replaced.

(d) Such markings shall not be requisitioned separately.

(4) When the illustration of a part or nonrepairable assembly seems to be incomplete with the marking omitted, it is proper to show, but not list, the marking.

t. Support equipment.

(1) Support equipment items requiring breakdown. Breakdown of support equipment listed in support of an end item shall be included when:

(a) The support equipment is peculiar to support the end item.

(b) Provisioning documentation dictates repair of the support equipment at the maintenance level coverage of the end item.

(c) A separate publication is not available or has not been authorized.

(2) Logistically nonrepairable support equipment. An illustration, part number, description of the item and units per assembly shall be included for these types of end items.

5.6.2.3 Description. The description **<partdesc>** as obtained from engineering drawings of the part listed shall be listed as an entry under the heading "DESCRIPTION." Additional specific technical content requirements for parts description are provided in 5.6.2.3 e through 5.6.2.3 ac. The systems, subsystems, equipment, support equipment, components, and parts of the end item shall be indented to show next higher assembly relationship as follows:

a. Indentions to show item relationship. The end item nomenclature shall not be indented and shall be flush with the left margin in the description. Parts that comprise the end item shall be listed using indentions to show next higher assembly relationship. Runover lines of nomenclature should be indented an additional indentation from the first line of nomenclature. Indention should be indicated by leaders (a series of periods or dots) with one leader equal to one indention. Indention to show end item to assembly, subassembly, and detailed part relationships shall be presented as shown in the following example:

MIL-STD-3001-8(AS)

END ITEM (FIGURE COVERAGE) <enditem>

Runover line of nomenclature for End Item (Figure coverage)

. Detailed parts for End Item (Figure coverage) <detlparts>

. ASSEMBLY <assy>

(ATTACHING PARTS)

. Attaching parts for ASSEMBLY <attachpart>

---*---

. . Detailed parts for ASSEMBLY <detlparts>

. . SUBASSEMBLY <subassy>

(ATTACHING PARTS)

. . Attaching parts for SUBASSEMBLY

---*---

. . . Detailed parts for SUBASSEMBLY

. . . SUB-SUBASSEMBLY <subassy>

(ATTACHING PARTS)

. . . Attaching parts for SUB-SUBASSEMBLY

---*---

. . . . Detailed parts for SUB-SUBASSEMBLY

b. Parts kits.

(1) A statement indicating parts(s) availability shall be included after the description of the item or unit for which the kit is supplied.

(2) The kit(s) part numbers shall be placed last in the list of parts of the unit to which it applies and at the same indentation as the unit to which it applies.

(3) Part kits shall be at the same indentation as the unit to which it applies.

(4) Kit contents shall be at one indent below the kit description.

(5) Lists of supplemental kits shall follow the list of original kits in the same manner as prescribed herein.

c. Listing attaching parts. Attaching parts shall be listed beneath the item to be attached. They shall be listed, preceding any detailed parts of the item, at the same indentation as the part they attach. The caption "(ATTACHING PARTS)" shall be placed one indentation to the right of the nomenclature of the part to be attached, on the line immediately above the list of attaching parts. The symbol "---*---" shall follow the attaching parts, to separate the list from subsequent listings of parts. The separation symbol shall have the same indentation as "(ATTACHING PARTS)."

(1) If common attaching parts are used for more than one item and each item is assigned a separate index number, the attaching parts heading shall be expanded to so indicate. For example, if two clamps (one indexed -3; the other -4) are attached by one bolt, the correct attaching parts heading is "(ATTACHING PARTS FOR INDEX NUMBERS 3 AND 4)."

MIL-STD-3001-8(AS)

(2) If the attaching parts are the same for a number of items and these items are indexed and listed separately one after the other, the attaching parts shall be listed following the last item, and the attaching parts heading shall be expanded to indicate this. For example, if six connectors, each having a different part number with the same attaching parts, are indexed -1 through -6, the correct attaching parts heading is "(ATTACHING PARTS FOR EACH OF INDEX NUMBERS 1 THRU 6)."

d. Nomenclature consistency. Nomenclature of identical systems, subsystems, equipment, support equipment, components, and parts of the end item shall be consistent throughout the GAPL and from work package to work package. The correct nomenclature shall be derived from one of the following sources (listed in the order of precedence):

- (1) "AN" nomenclature,
- (2) Nameplate nomenclature,
- (3) H-6 assigned nomenclature, or
- (4) Nomenclature on the drawing from which the item was manufactured.

e. Identifying noun and noun modifiers. The identifying noun should be the first word of the description. Modifiers shall be arranged in the sequence as necessary to indicate specifics such as function and location, and to maintain consistency of nomenclature. Modifiers shall be added to the description of parts as required to assure positive identification; for example: washer, flat and washer, lock. These modifiers need not appear on the preparing activity drawing. For additional information, refer to MIL-HDBK-3001.

f. Hardness critical items. When the part is identified as a hardness critical item (HCI), the symbol [HCI] shall precede the nomenclature of the part in the "DESCRIPTION" entry. It is preferred that the symbol be placed within brackets, that is, [HCI]; however, other methods of highlighting the symbol to call attention to its importance are acceptable.

g. Electrostatic discharge (ESD) sensitive parts. When a part is identified as an item subject to electrostatic discharge (ESD), the symbol should precede the first word in the "DESCRIPTION" entry. It is preferred that the symbol be placed within brackets, that is, [ESD]; however, other methods of highlighting the symbol to call attention to its importance are acceptable.

h. Abbreviation "ASSY or INSTL". If the item is an assembly or installation, the abbreviation "ASSY or INSTL," as applicable, shall follow the noun.

i. Drawing modifiers. The identifying noun or "ASSY" or "INSTL" shall be followed by the modifiers included in the drawing title description, and, when applicable, modifiers such "upper," "lower," "inner," "outer," "front," and "rear" shall follow.

j. Commercial and Government Entity (CAGE) Codes < Cage >. Manufacturers' codes (or complete name if no code has been assigned) and references to other manuals or figures shall follow the description of the item. Manufacturers' codes shall not be listed for Government standard parts.

k. Dimensions. Where units of measurement are the same, they shall not be repeated with each dimension, for example: "1/8 by 21/32 inch." A zero shall precede the decimal point of decimal values less than one, e.g., "0.5."

MIL-STD-3001-8(AS)

- l. Capitalization. The entire description may be in upper case letters. As a minimum, the item name shall be in upper case letters and the first letter of the first word immediately following the item name, and the first letter of proper nouns shall be upper case.
- m. Abbreviations. Abbreviations shall be held to a minimum. Abbreviations shall be in accordance with MIL-HDBK-3001. Abbreviations shall be consistent throughout WPs.
- n. Leaders. Leaders (a series of periods or dots) shall be used to join the description and the "UNITS PER ASSY" column. When the description requires more than one line, leaders shall only be used on the first line.
- o. Tolerances for electrical/electronic parts <tolerance>. Percentages or actual values or allowable tolerances for such items as nonmilitary standard resistors and capacitors shall be given as part of the description, expressed as plus and minus values.
- p. Undrilled or untrimmed parts <drilltrim>. Parts that require drilling or trimming on installation shall be identified by a notation to that effect in the description.
- q. Make from instructions. Most parts source coded MO, MF, MH, or MG require manufacturing instructions in the maintenance WP. These parts shall not have "Make From" information in the description column but will reference the maintenance WP. M-Series parts requiring only length, width or thickness and not requiring special manufacturing instructions shall include the raw bulk stock and final dimensions in the description. The list of raw (bulk) stock shall not be included for parts to be fabricated at depot level (SM&R coded MD).
- r. Items using liquid oxygen (LOX). Items using LOX shall be identified by the acronym LOX if hazardous conditions could result from lack of this information. The acronym shall be placed at the far right on the same line containing the nomenclature of the part.
- s. Quick engine change assembly (QECA).
- (1) Repair parts, Government-furnished equipment and approved contractor-furnished accessories of an aircraft engine, that also are included in the Quick Engine Change Assembly (QECA) shall be identified by the acronym "QEC" following the description of each repair part. The acronym shall appear at the far right on the same line containing the nomenclature of the part .
 - (2) Following the breakdown of the quick engine change assembly, the part number and description of the Quick Engine Change Kit (QECK) shall be listed. All QECK parts shall be illustrated and indexed.
 - (3) Basic aircraft engine parts shall not be identified with the acronym "QEC."
- t. Magnetic control items (MAG). Parts requiring test for magnetic inclusion shall be identified by the acronym "MAG" to assist in the identification of such parts when malfunctions could result because of the lack of this information. The acronym shall appear at the far right on the same line containing the nomenclature of the part.
- u. Oversize and undersize parts (dimensional differences) <size>. When oversize or undersize parts are required and furnished and they are neither interchangeable with, nor within allowable production tolerances of, the standard size part, they shall be listed by the part number specified in the contract drawing specification. All dimensional differences shall be included in the description.

MIL-STD-3001-8(AS)

v. Similar assemblies.

(1) Peculiar parts notation. Parts peculiar to only one assembly shall be identified by a note in the description.

(2) Different quantity notation. Identical parts that are used in different quantities on the assemblies shall be listed separately and identified by a note in the description.

w. Matched parts (notation and parts listing). When two or more parts that would normally be procured as separate items have been machined to fit as a matched set or lapped assembly, or have been matched electronically to meet circuit requirements, the set of items shall be assigned a separate part number. A notation in the description column shall indicate that the item consists of a matched set or matched pair. The part numbers and nomenclature of the items that make up the set shall be listed in the description.

x. Subcontractor or vendor items (identification and/or drawing number) <specdwg>. The descriptions of such items shall include the type, model, or applicable Government specification and the applicable manufacturer's code. If the manufacturer's code is not available, the name and address of the manufacturer shall be given. If such items are illustrated on preparing activity specification control or envelope drawings, the specification control or envelope drawing number shall also be listed in the description.

y. Redesigned parts. If the original part has continued application, "Alternate for" or "Use until exhausted," as applicable, shall follow the description of the part.

z. Selected items. If a component board contains a detail part which can be replaced from a selection of components of different values, the description shall contain the basic part number without the specific value, for example: "RCO7GF--J." If the selection is to be made after test, a note shall appear after the description of the part, for example: "/Value determined at test/."

aa. References to other manuals. If coverage of the end item is contained in another manual, the applicable end item shall be listed and reference made to the manual. The reference shall appear after the item description, in diagonals or parenthesis, for example: "/Breakdown, NAVAIR 01-85ADA-4-6/" or "(Breakdown NAVAIR 01-85ADA-4-6)."

ab. References to other figures in the same manual or volumes of the manual. If coverage is contained in another figure or WP, the applicable end item shall be listed and reference made to the figure number. If an item has additional maintenance coverage in another WP, the reference to that WP shall appear after the item description, in diagonals or parenthesis, for example: "/Breakdown, F0011-00/" or "(Breakdown, F0026 00)."

ac. Next higher assembly references. Necessary reference shall be made to other figures for next higher assemblies. The reference shall appear after the item description, in diagonals or parenthesis, for example: "/NHA, F0079-00/" or "(NHA, A1-F18AA-XXX-XXX F0081-00)."

5.6.2.4 Units per assembly <units>. The number of units required per assembly, per subassembly, and per sub-subassembly, as applicable, shall be listed as an entry under a heading "UNITS PER ASSY."

a. The entries under "UNITS PER ASSY" shall be aligned with the first line of multiple-line descriptions.

MIL-STD-3001-8(AS)

- b. If more than one assembly is required, the total of such assemblies shall be indicated.
- c. For detailed or subassembly parts of a major assembly, the quantity required for one major assembly shall be indicated.
- d. For oversize or undersize parts, the letters "AR" shall be placed in this column to indicate "as required."
- e. For items that are listed for reference, the letters "REF" (item found elsewhere in the IPB) shall be placed in the column.
- f. Quantities of attaching parts shall be listed per unit (piece) only. For example, if two fittings are required for each preceding assembly and one bolt is required to attach both fittings, the correct listing is as follows:

DESCRIPTION	UNITS PER ASSY
FITTING ASSY, HINGE (ATTACHING PARTS)	2
BOLT	1
---*---	

5.6.2.5 Usable on code <useoncode>. Usable on codes for assemblies and parts to indicate their specific usability with the end item to which the IPB figure applies shall be listed as an entry under a heading "USABLE ON CODE." Capital letters shall be used to identify the application of the items. If single letters of the alphabet are not sufficient to complete coding, double letters may be used, e.g., AA, AB, etc. The letters O and I shall not be used singularly or in pairs. No usable on code shall be used for assemblies and parts that are applicable to all end items.

- a. Simple application. When different end item part numbers are identified, each end item will be assigned a code in sequence and that code will be listed for each peculiar item in the parts list. More than one code may be assigned to the same item, e.g., A, B or A, C.
- b. Redesigned parts. If the original part has continued application, the applicable model, block numbers, and serial numbers of the items on which the part is usable shall be indicated by usable on codes.
- c. Alternate parts. An alternate part is defined as a part that is used when a preferable part is not available. When an item is completely interchangeable but one part is preferable for use, the number of the preferred part shall be listed without a notation in the "USABLE ON CODE" entry and all alternate part numbers shall be listed with an asterisk (*) in the "USABLE IN CODE" entry. When an item is completely interchangeable on certain end items but one part number is preferable for use, the "USABLE ON CODE" entry will carry the end item identification, with or without an asterisk (*), as applicable.
- d. Equivalent parts. An equivalent part is defined as a part that is used interchangeably with one or more parts, none of which are preferable over the other. All equivalent part numbers shall be listed with an asterisk (*) in the "USABLE ON CODE" entry. When a part is interchangeable only on certain end items, the "USABLE ON CODE" entry will carry the end item identification in addition to the required asterisk (*).

MIL-STD-3001-8(AS)

5.6.2.6 SM&R code <smrcode>. The source, maintenance and recoverability (SM&R) code for every part for which one has been approved by the Government shall be listed as an entry under a heading "SM&R CODE."

5.6.2.7 Work unit code (WUC) <wuc>. When the equipment, assembly, subassembly, or component part has been assigned a WUC, the WUC shall be listed under this entry.

5.6.2.8 Detailed IPB technical content requirements. General guidelines for IPB GAPL and illustration development are provided in 5.6.2 through 5.6.2.7. Additional detailed technical content requirements for GAPL and illustration development are contained in 5.6.2.8.1 through 5.6.2.8.9.

5.6.2.8.1 Nuclear hardness critical items (HCI), (CSI) or (OCI). When survivability considerations are specified and Hardness Critical Items (HCI) are identified on drawings and parts lists, the items must be marked and identified in the "DESCRIPTION" entry of the Group Assembly Parts Lists (GAPL). All changes to or proposed substitutions of HCIs must be evaluated for hardness impacts by the engineering activity responsible for survivability. The Introduction shall include an explanation of the (HCI) symbol's usage and method of highlighting and other pertinent information as necessary to emphasize uniqueness of HCIs.

5.6.2.8.2 Electrostatic discharge (ESD) sensitive parts. If electronic equipment to be handled, inspected, repaired or assembled is ESD sensitive, the items must be marked and identified in the "DESCRIPTION" entry of the GAPL. The Introduction shall include an explanation of the (ESD) symbol's usage and method of highlighting and other pertinent information as necessary to emphasize uniqueness of ESD sensitive components.

5.6.2.8.3 Index numbers on illustrations. Index numbers, with leader lines to the parts to which they pertain, shall be used on all IPB illustrations. Index numbers are assigned in accordance with 5.6.2.1. The index numbers on each illustration shall agree with those in the GAPL. Additional nomenclature may be added to these illustrations to properly identify parts not listed and indexed in the GAPL in order to properly indicate the relationship of parts to assemblies and to better present the maintenance procedures.

5.6.2.8.4 Attaching parts on illustrations. Each part in a set of attaching parts (such as bolt, washer, nut) shall be assigned an index number. Sets of attaching parts shall be exploded when the assembly is hidden and sufficiently complex to merit explosion. The total quantity of each item listed in the GAPL shall be identified with index numbers in the illustration. To avoid cluttering an illustration with unnecessary index numbers, large quantity items need not be indexed more than once on the illustration or on each sheet of a multisheet illustration that the part is shown. However, the location of the items must be obvious in the illustration. For example, multiple size rivets that are shown in various locations on the illustration need only be indexed once for each part number listed in the GAPL.

5.6.2.8.5 Indexing assemblies. Each assembly and subassembly of the end item shall be shown assembled and assigned an index number. Assemblies and subassemblies coded for assembly, manufacture, or repair at the applicable maintenance level shall also be shown exploded in a detail view on the main illustration or in a separate illustration, and index numbers shall be assigned to all detailed parts.

5.6.2.8.6 Items not having a logical maintenance sequence. For items not having a logical maintenance sequence (e.g., circuit card assembly), begin assigning index numbers at the top left-hand corner and continue clockwise.

MIL-STD-3001-8(AS)

5.6.2.8.7 Component boards. When a component board or bracket assembly that holds electrical components is presented orthographically, the reference designation may be placed within the view of the part, if space permits. Leader lines may be used to identify reference designations that cannot be placed within the view of the part. When the number of leader lines to indexed parts causes the illustration to become cluttered, the figure may contain a legend adjacent to the artwork or on a separate sheet. The listing shall contain an alphanumerical listing of the reference designations and their associated index numbers. Index numbers for items with reference designations shall be identified using the legend and not on the artwork. Index numbers will be used only to identify items that do not have reference designations.

5.6.2.8.8 Polarity identification. When applicable, the polarity of electronic components shall be identified on the component of all maintenance illustrations.

5.6.2.8.9 Reference designations <refdes>. Illustrations that depict electrical components should include reference designation after the index number. If an orthographic view is prepared, the reference designation may be placed within the view of the part, if space permits.

6. NOTES.

The notes in section 6 of MIL-STD-3001-1 apply to this Part.

MIL-STD-3001-8(AS)

A1-H53CD-SEC-000

1 March 1996

5.2.2

Page A

NUMERICAL INDEX OF EFFECTIVE FIGURES/PAGES

List of Current Changes

Original 0.....1 March 1996

Only those figures/pages assigned to the manual are listed in this index. Dispose of the superseded issues of the technical manuals. Superseded classified technical information shall be destroyed in accordance with applicable regulations. The portion of text affected in a changed or revised manual is indicated by change bars or the change symbol "R" in the outer margin of each column of text. Changes to illustrations are indicated by pointing hands or change bars, as applicable.

Total number of pages in this manual is 62 consisting of the following:

Figure No./Page No.	Change No.	Figure No./Page No.	Change No.	Figure No./Page No.	Change No.
Title.....	0	F0025-00	0	F0027-00/6-10.....	0
A	0	F0026-00	0	F0028-00	0
TPDR-1	0	F0027-00/1-4.....	0	F0029-00	0
TPDR-2 Blank	0	F0027-00/5	0		
~~~~~					

FIGURE 1. Example of a numerical index of effective figures/pages.

MIL-STD-3001-8(AS)

NAVAIR XXXXXX

INDEX-1

15 April 1980

5.3

---

 ALPHABETICAL INDEX  
 POWER PLANT AND RELATED SYSTEMS
 

---

5.3b → Title	Figure Number
Afterburner Fuel and Exhaust Control System	F0057-00
Control, Fuel	F0058-00
Cooler, Fuel Oil	F0060-00
Pump, Fuel	F0061-00
Pump, Fuel Hydraulic	F0062-00
Valve, Fuel Ignition	F0059-00
Air Inlet Control System	F0078-00
Gage Pressure	F0083-00
Probe Angle of Attack	F0080-00
Programmer	F0082-00
Sensors	F0080-00
Valve Air Relief	F0081-00
Valve Pneumatic Reservoir and Relief	F0079-00
Angle of	F0080-00
	F0090-00
Engine Compression Bleed System	
Control Mid Compression Bleed	F0097-00
Door Bleed Exit	F0096-00
Servocylinder Bleed Exit Door	F0096-01

FIGURE 2. Example of alphabetical index.

## MIL-STD-3001-8(AS)

<b>A1-F18AA-XXX-XXX</b>		5.4	<b>N0002-00</b>	
5.4.1a	5.4.1b			
<u>PART NUMBER</u>	<u>FIGURE/INDEX NUMBER</u>	<u>PART NUMBER</u>	<u>FIGURE/INDEX NUMBER</u>	
RER75F20R0M	F0010-00/200	SIR36B	F0023-01/4	
RER75F24R9R	F0010-00/196	SKT102PC-WHT	F0106-00/6	
RER75F4R02R	F0010-00/190	SPR-4	F0030-00/21	
RER75F6R00P	F0031-03/32	SPR-4A	F0030-00/22	
RER75F6R02R	F0008-00/31	TVA1962	F0004-00/52	
RH-10-10W-01	F0010-00/120	TY-546 MT	F0032-00/12	
RN60D1102F	F0009-00/10		F0032-00/18	
RN60D1212F	F0009-00/11		F0057-00/10	
RN60D1302F	F0008-00/5		F0057-00/15	
RN60D2202F	F0023-00/4		F0080-00/29	
RN60D3012F	F0008-00/4		F0080-00/50	
RN60D5622F	F0023-00/8		F0103-00/94	
RN65D1001F	F0015-00/2		F0152-00/17	
RN65D1002F	F0005-00/8		F0157-00/17	
	F0011-00/3		F0173-00/146	
RN65D1021F	F0012-00/1		F0173-00/158	
RN65D1212F	F0011-00/5	TY-546-MT	F0033-00/4	
RN65D1912F	F0005-00/7	TY-546MT	F0032-00/3	
RN65D20R0F	F0016-00/9		F0032-00/8	
RN65D2002F	F0005-00/3		F0033-00/86	
RN65D2212F	F0011-00/3		F0057-00/102	
RN65D2372F	F0011-00/4		F0057-00/132	
RN65D2672F	F0014-00/9		F0094-00/140	
RN65D2802F	F0015-00/10		F0095-00/154	
RN65D2871F	F0023-01/13	TY546MT	F0033-00/22	
RN65D2942F	F0005-00/8	T0659090F	F0023-01/16	
RN65D3011F	F0015-00/5	T31019	F0023-01/30	
RN65D3012F	F0015-00/6	UG-1094-B/U	F0010-00/17	
RN65D32R4F	F0016-00/10	WMF6P47	F0107-00/3	
RN65D3402F	F0015-00/7	WSLM-33	F0033-00/162	
RN65D4420F	F0023-01/12	X-100 BLK	F0128-00/10	
RN65D4990F	F0015-00/12	X-100 BLU	F0128-00/11	
RN65D4991F	F0015-00/3	X-100 GRN	F0128-00/12	
RN65D111F	F0015-00/1	X-100 ORN	F0128-00/13	
RN65D52942F	F0011-00/2	X-100 RED	F0128-00/14	
RN65D7216	F0023-01/10	X-100 YEL	F0128-00/15	
RN65D80R6F	F0012-00/2	00-7008-035-163	F0004-00/33	
S-202	F0014-00/1		F0010-00/132	
	F0015-00/3/1	00-7022-035-000	F0005-00/17	
S-203	F0005-00/16		F0006-00/13	
	F0006-00/1		F0007-00/10	
	F0007-00/1		F0114-00/15	
SE12XC04	F0011-00/11		F0115-00/8	
SE12XC04S	F0012-00/13	001	F0007-00/10	
	F0013-00/11	013-2049-47-9	F0031-03/42	
	F0016-00/15	022UF10PC	F0023-01/3	
	F0017-00/7	09008	F0027-00/56	
SE26XF02	F0004-00/48	1K0HM05W	F0023-01/17	
SE26XF03	F0103-00/16	1N32	F0109-00/2	

FIGURE 3. Example of a numerical index of part numbers.

## MIL-STD-3001-8(AS)

A1-F18AA-XXX-XXX

5.4

N0001-00

15 November 1979

NUMERICAL INDEX OF PARTS NUMBERS  
ILLUSTRATED PARTS BREAKDOWN  
POWER SUPPLY AN/XXX-123

<u>PART NUMBER</u>	<u>PUBLICATION/ FIGURE/INDEX NUMBER</u>	<u>PART NUMBER</u>	<u>PUBLICATION/ FIGURE/INDEX NUMBER</u>
AFD56-24-98SN-1A	120-450/F0033-00/5	EMW2868-1100-50	630-450/F0023-00/7
AN-3064-6	120-450/F0004-00/6	ET100X063A4	230-450/F0009-00/6
AN3420-10	120-450/F0031-01/8		760-450/F0023-00/7
AN3420-12	120-450/F0031-01/8	ET151X04A00	410-450/F0009-00/6
AN3420-16	140-450/F0033-00/5	ET681X040A03	120-450/F0009-00/6
AN3420-20	140-450/F0033-00/5	FSR-306D	410-450/F0102-00/9
AN3420-6	140-450/F0033-00/5	FU5R773312	650-450/F0023-01/2
AN3420-8	140-450/F0031-01/8	F92A	140-450/F0040-00/6
AN960C-816	140-450/F0007-00/4	GE50-236402AAA1	140-450/F0030-00/9
AR100L.25	760-450/F0100-00/7	IN3278	140-450/F0008-00/6
AR200L.25	410-450/F0110-00/7		230-450/F0008-00/6
C-300-S-20	760-450/F0019-00/6	IN4002	230-450/F0008-00/6
C-300-5-20	760-450/F0027-00/7	IN4005	230-450/F0023-01/2
CLS-256-2	120-450/F0029-00/4	IN4154	230-450/F0023-01/2
CL65D100KPE	120-450/F0023-01/2	IN4999	120-450/F0023-01/2
CMR06F202J0DM	120-450/F0005-00/5	IN5225	720-450/F0023-01/2
COVER	120-450/F0030-00/9	IN746A	720-450/F0008-00/6
CT3A2	630-450/F0010-00/9	JAN IN161	720-450/F0118-00/7
C016B102E501W	630-450/F0008-00/6	JQE-36-15M-VP	720-450/F0124-00/3
C280AEA10K	140-450/F0008-00/6	JQE25-20M-VP	720-450/F0020-00/6
DB-25S	760-450/F0033-00/5		720-450/F0021-00/5
DBM13W35	760-450/F0034-00/6	JQE36-20M-VP	720-450/F0025-00/4
DC-37S	760-450/F0033-00/5	KRP14DG24VDC	420-450/F0010-00/9
DCM-37P	420-450/F0033-00/5	LL20R	140-450/F0009-00/6
DCM37P		LMZ42CH(MS1741)	650-450/F0023-01/2
DM522		LM103:3:9	650-450/F0023-01/2

FIGURE 3. Example of a numerical index of part numbers - continued.

## MIL-STD-3001-8(AS)

A1-F18AA-XXX-XXX

R0001-00

30 April 1978

5.5

**NUMERICAL INDEX OF REFERENCE DESIGNATIONS  
ILLUSTRATED PARTS BREAKDOWN  
POWER SUPPLY AN/XXX-123**

5.5.1a			5.5.1c		
↓	↑			↓	↑
REFERENCE DESIGNATION	PUBLICATION/ FIGURE/INDEX NUMBER	PART NUMBER	REFERENCE DESIGNATION	PUBLICATION/ FIGURE/INDEX NUMBER	PART NUMBER
1A1	760-450/F0012-00/1	392AS110	1A2C1	650-450/F0004-00/52	TVA1962
1A1CB1	760-450/F0003-00/6	392AS118-1	1A2E1	760-450/F0004-00/48	SE26XF02
1A1CB2	760-450/F0003-00/26	392AS118-1	1A2E2	720-450/F0004-00/8	1508-103
1A1CB3	760-450/F0003-00/3	392AS118-2	1A2J1	720-450/F0004-00/66	203736-4
1A1CB4	630-450/F0003-00/8	392AS118-2	1A2PS1	750-450/F0004-00/54	392AS210
1A1CB5	630-450/F0003-00/13	392AS118-2	1A2PS2	650-450/F0004-00/55	77M1P11
1A1DS1	690-450/F0003-00/12	MIL-3861/48	1A2P1	720-450/F0004-00/70	8714
1A1DS2	650-450/F0003-00/12	MIL-3861/48	1A2P2	720-450/F0004-00/69	17236
1A1DS3	650-450/F0003-00/9	MS03	1A2Q1	730-450/F0004-00/28	2N5230
1A1TB1	750-450/F0003-00/8	MS25068-23	1A2TB1	650-450/F0004-00/58	3012
1A1TB2	750-450/F0003-00/18	MS25068-23	1A2TB2	720-450/F0004-00/53	3004
1A1TB3	750-450/F0003-00/28	4-141	1A2TB3	750-450/F0004-00/56	3004
1A1TB4	750-450/F0003-00/19	5-141	1A2TB4	690-450/F0004-00/72	3006
1A1TB5	760-450/F0003-00/11	5-141	1A2TP1	650-450/F0004-00/9	1508-102
1A2	650-450/F0012-00/3	392AS150	1A2T3	630-450/F0004-00/61	P6469
1A2CB1	650-450/F0004-00/6	TVA1962	1A2T4	760-450/F0004-00/64	P6469
1A2CB2	690-450/F0004-00/7	M39019/5-28			

FIGURE 4. Example of a numerical index of reference designations.

## MIL-STD-3001-8(AS)

NAVAIR XXXXXX			R0002-00		
5.5			5.5		
5.5.1a			5.5.1b		
<u>REFERENCE DESIGNATION</u>	<u>FIGURE/INDEX NUMBER</u>	<u>PART NUMBER</u>	<u>REFERENCE DESIGNATION</u>	<u>FIGURE/INDEX NUMBER</u>	<u>PART NUMBER</u>
1A2A1	F0004-00/54	392AS151	1A2A2C7	F0006-00/34	MS9014/02-0212
1A2A1CR1	F0005-00/1	M1CS19500/1N75	1A2A2J1	F0006-00/54	SKT102PC-WHT
1A2A1CR2	F0005-00/4	CMR6904-JOC	1A2A2J2	F0006-00/57	SKT102PC-WHT
1A2A1C1	F0005-00/15	M39006/09-4114	1A2A2J3	F0006-00/53	SKT102PC-WHT
1A2A1C2	F0005-00/16	M39006/09-4114	1A2A2J4	F0006-00/50	SKT102PC-WHT
1A2A1C3	F0005-00/14	M39014/01-0210	1A2A2Q1	F0006-00/21	MIL-S-19500/2512
1A2A1C4	F0005-00/13	M39014/02-0212	1A2A2Q3	F0006-00/24	MIL-S-19500/2512
1A2A1C5	F0005-00/18	M39014/02-0212	1A2A2Q4	F0006-00/25	MIL-S-19500/2512
1A2A1C6	F0005-00/19	M39014/02-0212	1A2A2R1	F0006-00/40	RCR07G203JP
1A2A1C7	F0005-00/23	M39014/02-0212	1A2A2R2	F0006-00/60	RCR07G103JP
1A2A1C8	F0005-00/18	M39014/02-0212	1A2A2R3	F0006-00/42	RCR07G203JP
1A2A1C9	F0005-00/12	CMR06F202J0DM	1A2A2R4	F0006-00/44	RCR07G203JP
1A2A1C91	F0005-00/14	M39014/01-0210	1A2A2R5	F0006-00/43	RCR07G203JP
1A2A1C92	F0005-00/14	M39014/01-0210	1A2A2R6	F0006-00/63	RCR07G103JP
1A2A1C93	F0005-00/14	M39014/01-0210	1A2A2R7	F0006-00/47	RCR07G203JP
1A2A1C94	F0005-00/14	M39014/01-0210	1A2A2R8	F0006-00/27	RCR07G203JP
1R17	F0005-00/3	RN65D20C2F	1A2A2R91	F0006-00/49	RCR07G103JP
1A2A1R18	F0005-00/38	RN65D1002F	1A2A2R92	F0006-00/49	RCR07G203JP
1A2A1R19	F0005-00/2	RCR07G202JP	1A2A2R93	F0006-00/69	RCR07G103JP
1A2A1U1	F0005-00/2	392AS209	1A2A2R94	F0006-00/62	RCR07G103JP
1A2A1U2	F0005-00/31	392AS209	1A2A2R95	F0006-00/45	RCR07G203JP
1A2A1U3	F0005-00/20	392AS209	1A2A2R96	F0006-00/41	RCR07G203JP
1A2A1U4	F0005-00/32	392AS209	1A2A2R97	F0006-00/48	RCR07G203JP
1A2A1U5	F0005-00/33	392AS209	1A2A2R98	F0006-00/67	RCR07G103JP
1A2A2	F0004-00/79	392AS154	1A2A2R99	F0006-00/4	RCR07G203JP
1A2A2CR1	F0006-00/83	LM103-3.9	1A2A3CR2	F0007-00/37	1N3442
1A2A2CR2	F0006-00/85	LM103-3.9	1A2A3CR3	F0007-00/37	1N3442
1A2A2CR3	F0006-00/84	LM103-3.9	1A2A3CR4	F0007-00/38	1N3562
1A2A2CR4	F0006-00/86	LM103-3.9	1A2A3CR5	F0007-00/38	1N3563
1A2A2C2	F0006-00/16	M39006/09-4114	1A2A3CR6	F0007-00/18	1N3563
1A2A2C3	F0006-00/13	M39014/02-0212	1A2A3P1	F0007-00/10	00-7022-035-0001
1A2A2C4	F0006-00/31	M39014/02-0212	1A2A3Q1	F0007-00/5	MIL-S-19500/2N34
1A2A2C5	F0006-00/32	M39014/02-0212	1A2A3Q2	F0007-00/15	MIL-S-19500/2N34
1A2A2C6	F0006-00/33	M39014/02-0212			

FIGURE 4. Example of a numerical index of reference designations - continued.



A1-448XX-XXX-XXX

1 July 1984

F0179-00

Page 1

5.6.1

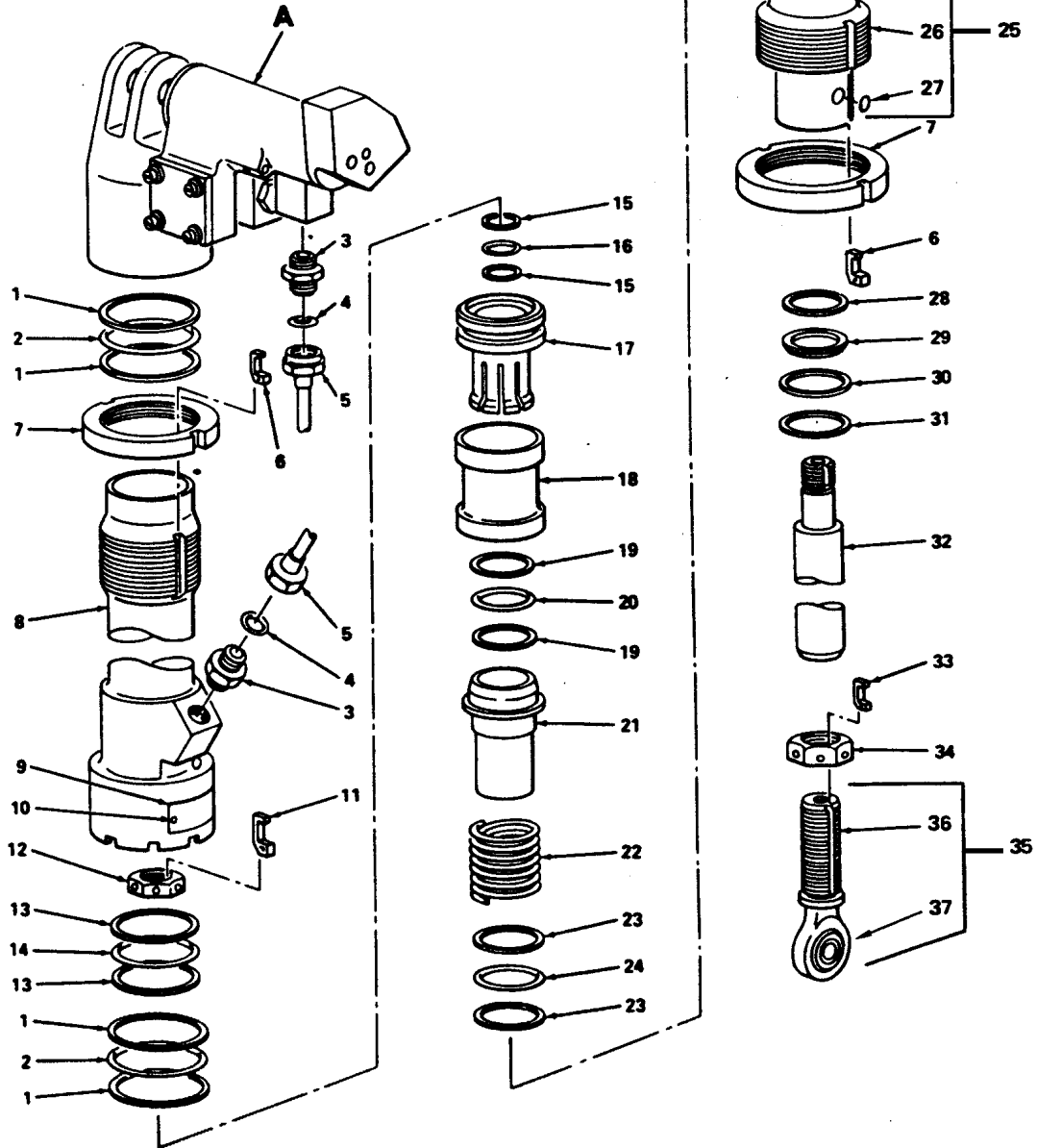

Actuator Assembly Main Landing Gear Uplock Hydraulic Part Numbers A51H10061-1, -2, -3, -4.

FIGURE 5. Example of IPB figure - separate IPB manual.

MIL-STD-3001-8(AS)

A1-448XX-XXX-XXX

5.6.1

F0179-00

Change 2 - 1 August 1985

Page 2

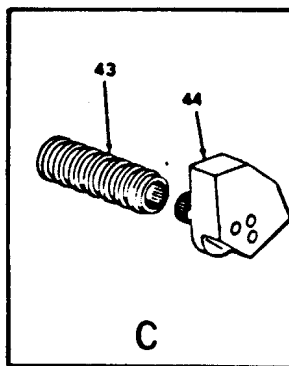
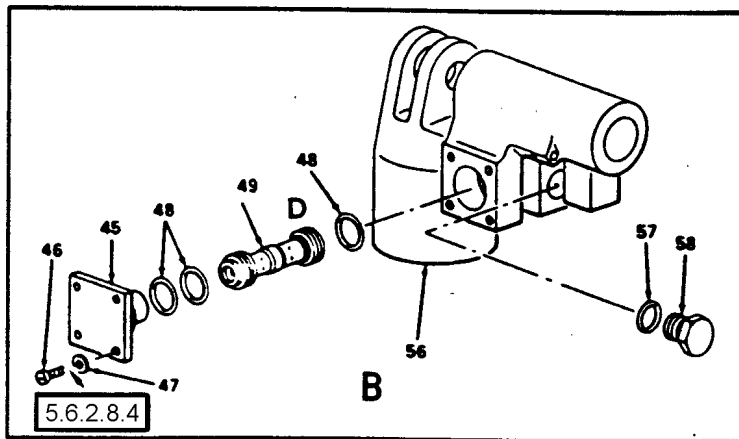
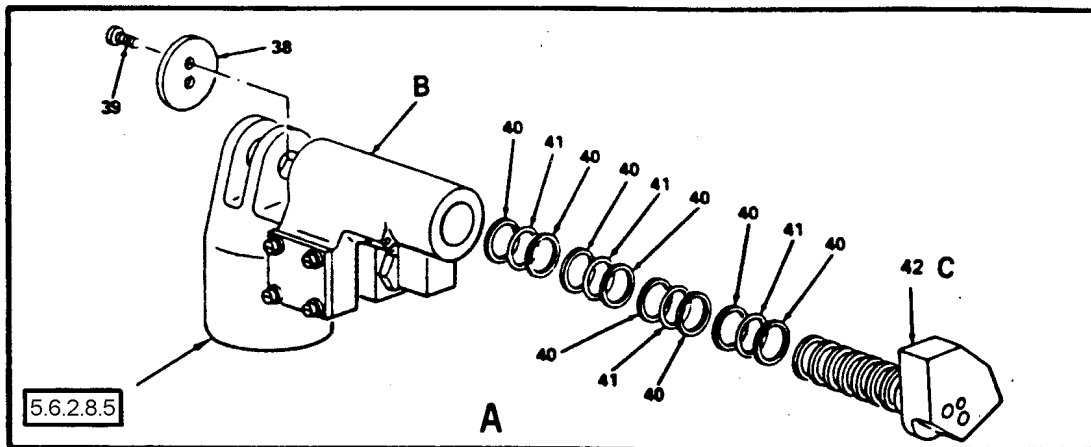

Actuator Assembly Main Landing Gear Uplock Hydraulic

FIGURE 5. Example of IPB figure - separate IPB manual - continued.

MIL-STD-3001-8(AS)

A1-448XX-XXX-XXX

5.6.2

F0179-00

Page 3

5.6.2.3

5.6.2.2

5.6.2.1.1

5.6.2.4e

5.6.2.3ac

5.6.2.5c

5.6.2.3q

5.6.2.5d

INDEX NO.	PART NUMBER	DESCRIPTION 1 2 3 4 5 6 7	UNITS PER ASSY	USABLE ON CODE	SM&R CODE
	A51H10061-1	ACTUATOR ASSY, MAIN LANDING GEAR . . . . .	REF	A	A0000
		UPLOCK, HYDRAULIC, LH/NHA, A1-F18AA-XXX-XXX,F0081-00/			
	A51H10061-3	ACTUATOR ASSY, MAIN LANDING GEAR . . . . .	REF	B	A0000
		UPLOCK, HYDRAULIC, LH/NHA, A1-F18AA-XXX-XXX F0081-00/			
	A51H10061-2	ACTUATOR ASSY, MAIN LANDING GEAR . . . . .	REF	A	A0000
		UPLOCK, HYDRAULIC, RH/NHA, A1-F18AA-XXX-XXX F0081-00/			
	A51H10061-4	ACTUATOR ASSY, MAIN LANDING GEAR . . . . .	REF	B	A0000
		UPLOCK, HYDRAULIC, RH/NHA, A1-F18AA-XXX-XXX F0081-00/			
1	MS28664-133	. RETAINER . . . . .	4		XBOZZN
2	MS28665-133	. PACKING . . . . .	2		XBOZZN
3	R45116T-0604	. REDUCER/50599/USE ONLY ON. . . . .	2		PAOGG
		A51H10061-1 ASSY/			
	R451167-7032	. REDUCER/50599/USE ONLY ON. . . . .	2		PAOGG
		A51H10061-2 ASSY/			
4	MS28778-4	. PACKING . . . . .	2		XBOZZN
5	COML	. LINE ASSY /0.250 OD X 0.016 INCH. . . . .	1		XBOZZN
		WALL, 3 AL - 2.5 V TUBING/			
6	A51H10048-1	. KEY, LOCKING /76462/ . . . . .	2		PAOZZ
	GK12A1	. KEY, LOCKING /76462/ . . . . .	2		PAOZZ
7	GN10FM34	. NUT, LOCKING . . . . .	2		PAOZZ
8	A51H10580-11	. BODY, LH. . . . .	1	A	PAOGG
	A51H10584-11	. BODY, LH. . . . .	1	B	PAOGG
	A51H10580-12	. BODY, RH. . . . .	1	A	PAOGG
	A51H10584-12	. BODY, RH. . . . .	1	B	PAOGG
9	G339-1A	. NAMEPLATE/DRILL ON INSTL/ . . . . .	1		MOOZZ
		(ATTACHING PARTS)			
10	AN535-00-2	. SCREW. . . . .	2		XBOZZN
		-----			
11	A51H10625-11	. KEY . . . . .	1		PAOZZ
	A51H10625-13	. KEY . . . . .	1		PAOZZ
12	GN10AU9	. NUT, TERMINAL LOCKING. . . . .	1		PAOZZ
13	MS28774-220	. RETAINER . . . . .	2		XBOZZN
14	MS28775-220	. PACKING . . . . .	1		XBOZZN
15	MS28774-016	. RETAINER . . . . .	2		XBOZZN
16	MS28775-016	. PACKING . . . . .	1		XBOZZN
17	A51H10615-11	. HEAD . . . . .	1	A	PAOGG
	A51H10631-11	. HEAD . . . . .	1	B	PAOGG

Actuator Assembly Main Landing Gear Uplock Hydraulic

FIGURE 6. Example of IPB GAPL - separate IPB manual.

## MIL-STD-3001-8(AS)

A1-448XX-XXX-XXX

F0179-00

Page 5

INDEX NO.	PART NUMBER	DESCRIPTION 1 2 3 4 5 6 7	UNITS PER ASSY	USABLE ON CODE	SM&R CODE
46	MS35275-263	. SCREW . . . . .	4		PAOZZ
47	AN960D10L	. WASHER . . . . .	4		PAOZZ
48	MS28775-115	. PACKING . . . . .	3		XBOZZN
49	2SV662	. VALVE ASSY, CARTRIDGE, SHUTTLE . . . . . /26044/ /GRUMMAN SPECIFICATION CONTROL DRAWING A51H9091-1/	1		A0000
50	2SVP62	. . FITTING/26044/ . . . . .	1		PAOZZ
51	MS28775-145	. . PACKING . . . . .	1		XBOZZN
52	2SVP15	. . POPPET ASSY/91207/ . . . . .	1		PAOZZ
53	MS19060-18	. . BALL/USE ONLY ON A51H10061-1 . . . . . ASSY/	2		XBOZZN
	MS19060-10	. . BALL/USE ONLY ON A51H10061-1 . . . . . ASSY/	2		XBOZZN
54	2SVS18	. . SPRING/26044/ . . . . .	1		PAOZZ
55	2SVH662	. . HOUSING/26044/ . . . . .	1		PAOGG
56	A51H10613-1	. FITTING, LH . . . . .	1	A	PAOGG
	A51H10613-3	. FITTING, LH . . . . .	1	B	PAOGG
	A51H10613-2	. FITTING, RH . . . . .	1	A	PAOGG
	A51H10613-4	. FITTING, RH . . . . .	1	B	PAOGG
57	MS28778-6	. PACKING . . . . .	1		XBOZZN
58	A51H10612-11	. RETAINER . . . . .	1		PAOZZ

Actuator Assembly Main Landing Gear Uplock Hydraulic

FIGURE 6. Example of IPB GAPL - separate IPB manual - continued.

## MIL-STD-3001-8(AS)

NAVAIR 03-XXXXXX

5.6.2

F0453-00

Page 2

INDEX NO.	PART NUMBER	DESCRIPTION	UNITS PER ASSY	USABLE ON CODE	SM&R CODE	
						1
	179100-2	SEPARATOR, WATER/AIR CONDITIONING, CABIN . . . . .	1		AGGGG	
		PRESSURIZATION, AND VENTILATION SUIT/ /70210/ /GRUMMAN SPECIFICATION CONTROL DRAWING 128SCEC155-1/ /PARTS KIT AVAILABLE/				
1	S8834B1P	. PLATE, IDENTIFICATION /70210/ . . . . .	1			
		/ATTACHING PARTS/				
2	MS24641-1	. SCREW . . . . .	2		ZBGZZN	
		-----				
3	S8165-1	. LABEL, DIRECTION OF GRAVITY /70210/ . . . . .	2		MGGZZ	
4	S8205-1	. LABEL, FLOW DIRECTION /70210/ . . . . .	1		MGGZZ	
5	U3452-538S	. CLAMP, COUPLING /94581/ . . . . .	1		PAGGG	
		/ATTACHING PARTS/				
6	AN123907	. PACKING . . . . .	2		PCGZZ	
		-----				
7	177432-1	. SHELL ASSEMBLY, WATER SEPARATOR . . . . .	1		PAGGG	
		INLET /70210/				
8	177429-1	. SHELL ASSEMBLY, WATER SEPARATOR . . . . .	1		PAGGG	
		OUTLET /70210/1				
9	177434-1	. CONDENSER ASSEMBLY, WATER SEPARATOR . . . . .	1		AFGGG	
		CONICAL				
10	83248	. . . . . SPRING, EXTENSION /70210/ . . . . .	1		KF	
11	83463-5	. . . . . CHAIN ASSEMBLY, WATER SEPARATOR /70210/ . . . . .	1		KF	
12	85898	. . . . . SPRING, EXTENSION /70210/ . . . . .	1		KF	
13	83237-15	. . . . . CONDENSER, WATER SEPARATOR . . . . .	1		PAGGG	
		CONICAL /70210/				
14	MS16625-4112	. . . . . RING . . . . .	1		KF	
15	84187	. . . . . VALVE ASSEMBLY, WATER SEPARATOR BYPASS . . . . .	1		PAGGG	
		/70210/				
16	177433-1	. . . . . SUPPORT ASSEMBLY, WATER SEPARATOR . . . . .	1		PAGGG	
		CONDENSER /70210/				
	591402-1	PARTS KIT, WATER SEPARATOR, FLEET /70210/ . . . . .	1		PA	
	83248	. . . . . SPRING, EXTENSION /70210/ . . . . .	1		KF	
	83463-5	. . . . . CHAIN ASSEMBLY, WATER SEPARATOR /70210/ . . . . .	1		KF	
	85989	. . . . . SPRING, EXTENSION /70210/ . . . . .	1		KF	
	MS16625-4112	. . . . . RING . . . . .	1		KF	
	89963	. . . . . PACKING /70210/ . . . . .	4		KF	

Separator, Water/Air Conditioning, Cabin Pressurization, and Ventilation Suit.

FIGURE 7. Example of parts kit.

MIL-STD-3001-8(AS)

CONCLUDING MATERIAL

Preparing activity:  
Navy - AS  
(Project TMSS N312)

# STANDARDIZATION DOCUMENT IMPROVEMENT PROPOSAL

## INSTRUCTIONS

1. The preparing activity must complete blocks 1, 2, 3, and 8. In block 1, both the document number and revision letter should be given.
2. The submitter of this form must complete blocks 4, 5, 6, and 7, and send to preparing activity.
3. The preparing activity must provide a reply within 30 days from receipt of the form.

NOTE: This form may not be used to request copies of documents, nor to request waivers, or clarification of requirements on current contracts. Comments submitted on this form do not constitute or imply authorization to waive any portion of the referenced document(s) or to amend contractual requirements.

### I RECOMMEND A CHANGE:

1. DOCUMENT NUMBER  
MIL-STD-3001-8(AS)

2. DOCUMENT DATE (YYYYMMDD)  
20010515

Digital Technical Information for Multi-Output Presentation of Technical Manuals Illustrated Parts Breakdown (IPB) (Parts 8 of 8 Parts)

### 5. REASON FOR RECOMMENDATION

### 6. SUBMITTER

a. NAME (Last, First, Middle Initial)

b. ORGANIZATION

c. ADDRESS (Include Zip Code)

d. TELEPHONE (Include Area Code)  
(1) Commercial  
(2) AUTOVON  
(if applicable)

7. DATE SUBMITTED  
(YYYYMMDD)

### 8. PREPARING ACTIVITY

NAME Commander, Naval Air Warfare Center  
Aircraft Division

b. TELEPHONE (Include Area Code)  
(1) Commercial (2) AUTOVON  
(732) 323-2947 624-2947

c. ADDRESS (Include Zip Code)  
Code 414100B120-3  
Highway 547  
Lakehurst, NJ 08733-5100

**IF YOU DO NOT RECEIVE A REPLY WITHIN 45 DAYS, CONTACT:**  
Defense Standardization Program Office (DLSC-LM)  
8725 John J. Kingman road, Suite 2533, Ft. Belvoir, VA 22060-2533  
Telephone (703) 767-6888 AUTOVON 427-6888