

**INCH-POUND**

MIL-STD-2219A  
w/CHANGE 1  
16 June 2008

---

SUPERSEDING  
MIL-STD-2219A  
18 July 2005

# DEPARTMENT OF DEFENSE STANDARD PRACTICE

## FUSION WELDING FOR AEROSPACE APPLICATIONS



AMSC N/A

AREA THJM

DISTRIBUTION STATEMENT A. Approved for public release, distribution is unlimited.

MIL-STD-2219A  
w/CHANGE 1

**FOREWORD**

1. This standard is approved for use by all Departments and Agencies of the Department of Defense.
2. Comments, suggestions, or questions on this document should be addressed to ASC/ENRS, 2530 Loop Road West, Wright-Patterson AFB, Ohio 45433-7101 or emailed to [EngineeringStandards@wpafb.af.mil](mailto:EngineeringStandards@wpafb.af.mil). Since contact information can change, you may want to verify the currency of this address information using the ASSIST Online database at <http://assist.daps.dla.mil/>.
3. The purpose of *MIL-STD-2219* is to standardize the requirements for fusion welding of metals used for aerospace flight hardware.

MIL-STD-2219A  
w/CHANGE 1

PARAGRAPH	CONTENTS	PAGE
1. SCOPE .....		1
1.1 Scope .....		1
1.2 Processes .....		1
1.3 Classification.....		1
1.4 Requirements and information .....		1
1.5 References within this document .....		1
2. APPLICABLE DOCUMENTS .....		2
2.1 General.....		2
2.2 Government documents.....		2
2.2.1 Specifications, standards, and handbooks.....		2
2.2.2 Other Government documents, drawings, and publications .....		3
2.3 Non-Government publications.....		3
2.4 Order of precedence .....		4
3. DEFINITIONS .....		5
3.1 Acronyms.....		5
3.2 General definitions.....		5
3.3 Clarification of classes .....		5
3.4 Acceptable.....		6
3.5 Arc strike.....		6
3.6 Buttering or build-up.....		6
3.7 Cognizant engineering organization.....		6
3.8 Finished weld.....		6
3.9 Government representative.....		6
3.10 Inspector.....		7
3.11 Qualification.....		7
3.12 Qualified welder/welding operator.....		7
4. GENERAL REQUIREMENTS .....		8
4.1 General requirements .....		8
4.2 Welding procedure qualification .....		8
4.3 Welding personnel qualification.....		8
4.4 Welding and auxiliary equipment .....		8
4.4.1 General.....		8
4.4.2 Welding apparatus capability .....		8
4.4.2.1 Furnace control equipment.....		8
4.4.2.2 Cooling furnaces.....		9
4.5 NDE procedure qualification .....		9
4.5.1 Radiographic inspection.....		9
4.5.2 Ultrasonic inspection.....		9
4.5.3 Magnetic particle inspection.....		9
4.5.4 Penetrant inspection .....		9

MIL-STD-2219A  
w/CHANGE 1

PARAGRAPH	CONTENTS	PAGE
4.5.5	Other nondestructive tests .....	9
4.6	Qualification of inspection personnel.....	9
4.6.1	Qualification of NDE personnel.....	9
4.6.2	Visual weld inspector .....	10
4.7	Vision test .....	10
4.8	Requalification .....	10
4.9	Identification.....	10
4.10	Records requirements.....	10
4.10.1	General.....	10
4.10.2	Records .....	10
4.10.2.1	General .....	10
4.10.2.2	Qualification records.....	11
4.10.2.2.1	Welding procedure qualification.....	11
4.10.2.2.2	Welder and welding operator qualification .....	11
4.10.2.2.3	NDE personnel qualification .....	11
4.10.2.3	NDE records.....	11
4.10.2.3.1	Radiographic inspection .....	11
4.10.2.3.2	Ultrasonic inspection .....	11
4.10.2.3.3	Magnetic particle inspection .....	11
4.10.2.3.4	Penetrant inspection.....	11
4.10.2.4	Inspection records .....	11
4.10.2.5	Workmanship .....	11
5.	DETAILED REQUIREMENTS.....	12
5.1	Welding consumables.....	12
5.1.1	Low hydrogen electrode storage.....	12
5.1.1.1	Exposure .....	12
5.1.2	Bare filler metal storage.....	12
5.1.3	SAW flux.....	12
5.1.4	Identification .....	12
5.1.4.1	Covered electrodes .....	12
5.1.4.2	Bare welding wire and welding rod .....	13
5.1.4.3	SAW flux .....	13
5.1.5	Gases .....	13
5.2	Manufacturing controls.....	13
5.2.1	Joint configuration.....	13
5.2.2	Preweld joint preparation .....	14
5.2.2.1	Surface finish of fusion faces.....	14
5.2.2.2	Joint and filler metal cleanliness .....	14
5.2.3	Pre-weld joint fit-up.....	14
5.3	Welding requirements .....	17

MIL-STD-2219A  
w/CHANGE 1

PARAGRAPH	CONTENTS	PAGE
5.3.1	Identification .....	17
5.3.2	Qualified weld settings .....	17
5.3.3	Reproducibility of qualified weld settings .....	17
5.3.3.1	When a sample is required .....	17
5.3.3.2	Sample preparation .....	17
5.3.4	Requalification of weld settings .....	17
5.3.5	Welding procedures .....	18
5.3.5.1	Filler metal .....	18
5.3.5.2	Preheating, interpass temperature control and postheating .....	18
5.3.5.2.1	Magnesium castings .....	18
5.3.5.2.2	Steels .....	18
5.3.5.2.3	Other base metals .....	19
5.3.5.3	Tackwelds .....	19
5.3.5.4	Fixtures .....	19
5.3.5.5	Weld start and run-off tabs .....	19
5.3.5.6	Weld shielding for GTAW, GMAW, and PAW .....	19
5.3.5.7	Cleaning between welds .....	19
5.3.5.8	Post weld cleaning .....	20
5.3.6	Stress relief .....	20
5.4	Inspection and acceptance criteria .....	21
5.4.1	General .....	21
5.4.2	Nondestructive inspection .....	21
5.4.2.1	Penetrant Inspection .....	21
5.4.2.2	Magnetic particle inspection .....	21
5.4.2.3	Radiographic inspection .....	21
5.4.2.4	Ultrasonic inspection .....	21
5.4.2.5	Extent of inspection .....	21
5.4.3	Weld configuration .....	22
5.4.3.1	Weld reinforcement and weld width .....	22
5.4.3.2	Weld penetration .....	22
5.4.3.3	Melt-through .....	22
5.4.3.4	Two and three piece tee joints .....	23
5.4.3.5	Fillet welds .....	25
5.4.4	Weld quality .....	25
5.4.4.1	General .....	25
5.4.4.2	Discontinuity limits .....	26
5.4.4.3	Discoloration of titanium .....	26
5.4.4.4	Discoloration of 300-series corrosion resistant steel and carbon and low alloy steels .....	26
5.4.5	Disposition of unacceptable welds .....	28

MIL-STD-2219A  
w/CHANGE 1

PARAGRAPH	CONTENTS	PAGE
5.4.5.1	Rejections.....	28
5.4.5.2	In-process correction .....	28
5.4.5.2.1	For Class A welds .....	28
5.4.5.3	Class B welds .....	29
5.4.5.4	Class C welds.....	29
6.	NOTES .....	30
6.1	Intended use .....	30
6.2	Acquisition requirements.....	30
6.3	Subject term (keyword) listing .....	30
6.4	Clarification and cross reference of classes .....	30
6.5	Welding safety .....	31
6.6	Cognizant engineering organization.....	31
6.6.1	Examples.....	31
6.7	Changes from previous issue.....	31
APPENDIX A.	Procedure Qualification Record (PQR) .....	33
APPENDIX B.	Welding Procedure Specification (WPS).....	35

## FIGURES

FIGURE 1.	Variations of root openings.....	15
FIGURE 2.	Allowable separation.....	15
FIGURE 3.	Two and three piece tee and seam weld joints.....	16
FIGURE 4.	Back beveling magnesium.....	16
FIGURE 5.	Weld reinforcement profiles.....	23
FIGURE 6.	Penetration profiles.....	23
FIGURE 7.	Melt through welds.....	24
FIGURE 8.	Melt through tee joints.....	24

## TABLES

TABLE I.	Gases (minimum requirements).....	13
TABLE II.	Maximum root opening.....	14
TABLE III.	Shielding gas and material combinations.....	20
TABLE IV.	Minimum fillet weld sizes.....	25
TABLE V.	Discontinuity limits.....	27

MIL-STD-2219A  
w/CHANGE 1

## 1. SCOPE

### 1.1 Scope

The scope of this document is to provide minimum requirements for weld filler materials, workmanship, inspection and record requirements for fusion welding of alloys applicable to aircraft, missiles, other aerospace equipment, their parts and accessories.

### 1.2 Processes

Fusion welding will be accomplished using one of the following processes.

- Flux Cored Arc Welding (FCAW)
- Gas Metal Arc Welding (GMAW)
- Gas Tungsten Arc Welding (GTAW)
- Oxyfuel Welding (OFW)
- Plasma Arc Welding (PAW)
- Submerged Arc Welding (SAW)
- Shielded Metal Arc Welding (SMAW)

### 1.3 Classification

The welds will be of the following classes:

- Class A
- Class B
- Class C

These classifications refer only to the levels of inspections required and to the quality standard levels applied as outlined in section 5 and TABLE V. Clarification of classes is given in 3.3.

### 1.4 Requirements and information

This document contains both mandatory requirements and guidance information. The mandatory requirements indicated by the words "shall" or "is required" are designed to serve as standards applicable to materials, workmanship, inspection, and quality control. Guidance information is indicated either by the words "should" or "may."

### 1.5 References within this document

References in this document to a particular paragraph or section number of this document will include all applicable subparagraphs under that paragraph or section

MIL-STD-2219A  
w/CHANGE 1

number. For example, a reference to paragraph 4.4 will include subparagraphs 4.4.1, 4.4.2, 4.4.2.1, etc.

## 2. APPLICABLE DOCUMENTS

### 2.1 General

The documents listed in this section are specified in sections 3, 4, or 5 of this standard. This section does not include documents cited in other sections of this standard or recommended for additional information or as examples. While every effort has been made to ensure the completeness of this list, document users are cautioned that they must meet all specified requirements of documents cited in sections 3, 4, or 5 of this standard, whether or not they are listed.

### 2.2 Government documents

#### 2.2.1 Specifications, standards, and handbooks

The following specifications, standards, and handbooks form a part of this document to the extent specified herein. Unless otherwise specified, the issues of these documents are those cited in the solicitation or contract.

#### FEDERAL SPECIFICATIONS

BB-A-106	Acetylene, Technical, Dissolved
BB-C-101	Carbon Dioxide (CO <sub>2</sub> ): Technical and USP
BB-H-886	Hydrogen
BB-H-1168	Helium, Technical
BB-O-925	Oxygen, Technical, Gas and Liquid

#### COMMERCIAL ITEM DESCRIPTIONS

A-A-59503	Nitrogen, Technical
-----------	---------------------

#### DEPARTMENT OF DEFENSE SPECIFICATIONS

MIL-A-18455	Argon, Technical
-------------	------------------

#### DEPARTMENT OF DEFENSE STANDARDS

MIL-STD-1916	DoD Preferred Methods for Acceptance of Product
--------------	---



MIL-STD-2219A  
w/CHANGE 1

(Copies of these documents are available online at <http://assist.daps.dla.mil/quicksearch/> or from the Standardization Document Order Desk, 700 Robbins Avenue, Building 4D, Philadelphia, PA 19111-5094.)

**2.2.2 Other Government documents, drawings, and publications**

The following other Government documents, drawings, and publications form a part of this document to the extent specified herein. Unless otherwise specified, the issues of these documents are those cited in the solicitation or contract.

**2.3 Non-Government publications**

The following documents form a part of this document to the extent specified herein. Unless otherwise specified, the issues of these documents are those cited in the solicitation or contract.

AEROSPACE INDUSTRIES ASSOCIATION OF AMERICA, INC. (AIA)

NAS410	NAS Certification & Qualification of Nondestructive Test Personnel
--------	--

(Copies of these documents are available from Aerospace Industries Association, 1000 Wilson Boulevard, Suite 1700, Arlington, VA 22209-3901 or online at <http://www.aia-aerospace.org>.)

AMERICAN SOCIETY FOR TESTING AND MATERIALS (ASTM)

ASTM-B600	Standard Guide for Descaling and Cleaning Titanium and Titanium Alloy Surfaces
ASTM-E1417	Standard Practice for Liquid Penetrant Examination
ASTM-E1444	Standard Practice for Magnetic Particle Examination
ASTM-E1742	Standard Practice for Radiographic Examination

(Copies of these documents are available from ASTM International, 100 Barr Harbor Drive, West Conshohocken, PA 19428-2959, or online at <http://www.astm.org>.)

AMERICAN WELDING SOCIETY (AWS)

AWS-A2.4	Standard Symbols for Welding, Brazing, and Nondestructive Examination
----------	---

MIL-STD-2219A  
w/CHANGE 1

AWS-A3.0	Standard Welding Terms and Definitions Including Terms for Adhesive Bonding, Brazing, Soldering, Thermal Cutting, and Thermal Spraying
AWS-A5.01	Filler Metal Procurement Guidelines
AWS-B2.1	Specification for Welding Procedure and Performance Qualification
AWS-D17.1	Specification for Fusion Welding for Aerospace Applications

(Copies of these documents are available from American Welding Society, 550 N.W. LeJeune Road, Miami, FL 33126, or online at <http://www.aws.org>.)

COMPRESSED GAS ASSOCIATION (CGA)

CGA-G1.1	Commodity Specification for Acetylene
CGA-G4.3	Commodity Specification for Oxygen
CGA-G5.3	Commodity Specification for Hydrogen
CGA-G6.2	Commodity Specification for Carbon Dioxide
CGA-G9.1	Commodity Specification for Helium
CGA-G10.1	Commodity Specification for Nitrogen
CGA-G11.1	Commodity Specification for Argon

(Copies of these documents are available from Compressed Gas Association, 4221 Walney Road, 5<sup>th</sup> Floor, Chantilly, VA 20151-2923 or online at <http://www.cganet.com>.)

SOCIETY OF AUTOMOTIVE ENGINEERS (SAE)

SAE-AMS2816	Identification Welding Wire, Tab Marking Method
SAE-AMS-STD-2154	Inspection, Ultrasonic, Wrought Metals, Process for

(Copies of these documents are available from SAE International, 400 Commonwealth Drive, Warrendale, PA 15096-0001 or online at <http://www.sae.org/>.)

**2.4 Order of precedence**

In the event of a conflict between the text of this document and the references cited herein, the text of this document takes precedence. Nothing in this document, however, supersedes applicable laws and regulations unless a specific exemption has been obtained.

MIL-STD-2219A  
w/CHANGE 1

### 3. DEFINITIONS

#### 3.1 Acronyms

The acronyms and letter designations used in this standard are defined as follows:

AFPRO	–	Air Force Plant Representative
DCAS	–	Defense Contract Administration Service
FCAW	–	Fluxcored Arc Welding
GMAW	–	Gas Metal Arc Welding
GTAW	–	Gas Tungsten Arc Welding
HAZ	–	Heat-affected-zone
NAVPRO	–	Navy Plant Representative
NDE	–	Nondestructive Examination
OFW	–	Oxyfuel Welding
PAW	–	Plasma Arc Welding
PQR	–	Procedure Qualification Record
SAW	–	Submerged Arc Welding
SMAW	–	Shielded Metal Arc Welding
WPS	–	Welding Procedure Specification

#### 3.2 General definitions

Unless otherwise defined herein, welding terms, definitions and symbols will conform to *AWS A2.4* and *AWS A3.0*.

#### 3.3 Clarification of classes

In this document, the classes detail what inspections are applicable and the allowable defect limits. It is up to the cognizant engineering organization to specify the inspections required for part after an assessment of part criticality is determined. The following clarification is given for information only to assist the design activity and is not mandatory.

- Class A: Critical application. A weldment is critical where a failure of any portion would cause loss of system, loss of major component, loss of control, unintentional release of critical stores, or endangering of personnel.
- Class B: Semi-critical application. A weldment is semi-critical when a failure would reduce overall efficiency of the system but loss of the system or endangering of personnel would not be experienced.
- Class C: Non-critical application. A weldment is non-critical where a failure would not affect the efficiency of the system or endanger personnel.

MIL-STD-2219A  
w/CHANGE 1

When the class is not specified in the contract or on the drawing, Class A will apply.

**3.4 Acceptable**

Complies with or conforms to the applicable standard or specification.

**3.5 Arc strike**

Any inadvertent localized heat-affected-zone (HAZ) or change in the contour of the finished weld or adjacent base metal resulting from an arc or heat generated by the passage of electrical energy between the surface of the finished weld or base metal and a current source, such as welding electrodes or magnetic inspection prods.

**3.6 Buttering or build-up**

The deposition of filler metal on a base metal surface to restore base material or weld surface dimensions, or to interpose a layer of weld metal on the material surface of the joint prior to joining the material members together.

**3.7 Cognizant engineering organization**

The engineering organization responsible for the design of the welded assembly. (See [6.6](#))

**3.8 Finished weld**

Welds which have received final inspection and have been accepted.

**3.9 Government representative**

Any Government representative specifically authorized to approve equipment, material, or procedures within the scope of this document. They can be, but are not limited to, the following:

- a. Contracting Officer
- b. DCAS
- c. AFPRO
- d. NAVPRO

There is no priority to this list. The contract will specifically identify the designated Government representative.

MIL-STD-2219A  
w/CHANGE 1

**3.10 Inspector**

Contractor, DCAS, and other Government representative qualified to accept or reject materials or workmanship.

**3.11 Qualification**

Conformance to the stated requirements of a document.

**3.12 Qualified welder/welding operator**

Any person who has met the requirements of *AWS D17.1 section 4*.

MIL-STD-2219A  
w/CHANGE 1

## 4. GENERAL REQUIREMENTS

### 4.1 General requirements

The purpose of these qualification requirements is to ensure that qualified procedures are used by properly trained and qualified personnel. It shall be the responsibility of the contractor to ensure that only qualified personnel, procedures, and nondestructive test equipment are used in fabrication and inspection necessary to comply with this document. Procedures and personnel previously qualified or approved shall not require requalification provided that qualifications are appropriate for the production welding to be done and have not lapsed, and provided that qualification records are available to substantiate prior qualification or approval.

### 4.2 Welding procedure qualification

Prior to engaging in production welding, the welding procedure for Classes A and B shall be qualified. The pertinent welding variables shall be identified. *Section 2 of AWS B2.1* should be used as a guideline in the development of the welding procedure to ensure that all pertinent variables and tolerances are included. Requalification criteria shall be determined by the cognizant engineering organization.

### 4.3 Welding personnel qualification

Each welder or welding operator shall be qualified in accordance with *AWS D17.1 section 4* prior to performing any production welding.

### 4.4 Welding and auxiliary equipment

#### 4.4.1 General

Welding equipment, such as welding machines, welding torches, regulators and filler metal feeders shall be capable of making satisfactory welds, when operated by a qualified welder or welding operator.

#### 4.4.2 Welding apparatus capability

Where doubts about the capability of any welding apparatus to function satisfactorily exists, the equipment shall not be used until the necessary repairs, adjustments, or replacements have been made.

##### 4.4.2.1 Furnace control equipment

Unless otherwise specified in the welding procedure documents, furnace control temperature tolerances shall be within  $\pm 50^{\circ}\text{F}$ .

MIL-STD-2219A  
w/CHANGE 1

**4.4.2.2 Cooling furnaces**

Cooling furnaces shall be provided with suitable means for controlling the cooling rate.

**4.5 NDE procedure qualification**

**4.5.1 Radiographic inspection**

Qualification of radiographic inspection procedures, including film processing procedures, shall be in accordance with *ASTM-E1742*.

**4.5.2 Ultrasonic inspection**

Qualification of ultrasonic inspection procedures shall be in accordance with *SAE-AMS-STD-2154*.

**4.5.3 Magnetic particle inspection**

Qualification of magnetic particle inspection procedures shall be in accordance with *ASTM-E1444*.

**4.5.4 Penetrant inspection**

Qualification of penetrant inspection procedures shall be in accordance with *ASTM-E1417*.

**4.5.5 Other nondestructive tests**

Nondestructive tests, procedures, techniques, equipment and materials not specifically addressed in this document may be used if approved in the contract or by the cognizant engineering organization.

**4.6 Qualification of inspection personnel**

**4.6.1 Qualification of NDE personnel**

Nondestructive examination personnel shall be qualified in accordance with *AIA/NAS410* or other NDE standards satisfactory to the cognizant engineering organization. When the contract, purchase order or engineering drawing specifies the use of examination methods not presently incorporated in *AIA/NAS410*, the manufacturer shall be responsible to develop and submit for approval to the cognizant engineering organization training programs, written procedures, examinations, and practical demonstrations equivalent to those required for the other examination methods covered by *AIA/NAS410* or other NDE standards. These shall establish the capability of the personnel to perform the required examinations.

MIL-STD-2219A  
w/CHANGE 1

#### **4.6.2 Visual weld inspector**

Personnel performing visual examinations shall be trained and qualified. Visual weld inspector qualification criteria and training shall be documented in a written procedure.

#### **4.7 Vision test**

Inspection personnel shall be required to pass an annual vision test. The test shall be conducted by a trained technician using the standard test methods for determining visual acuity. The standard of acceptance for the vision test shall be natural or corrected near distance acuity such that the individual is capable of reading J1 letters on the standard Jaeger type chart for near vision. Other equivalent visual tests may be substituted for the Jaeger Chart. Glasses or other corrective aids used to pass vision tests shall be worn when performing production work.

#### **4.8 Requalification**

Requalification of welders and welding operators shall be in accordance with *AWS D17.1 section 4*. Requalification of the weld procedures shall be as specified by the cognizant engineering organization (see 4.2). Requalification of NDE personnel shall be in accordance with *AIA/NAS410*.

#### **4.9 Identification**

Each welded assembly, or the documentation accompanying each welded assembly, shall be marked with the date and the signature or individually assigned stamp or code of the welder who made the weld, and with the date and signature(s) or individually assigned code or stamp of the inspector(s) who accepted the weld.

#### **4.10 Records requirements**

##### **4.10.1 General**

Written procedures shall assign responsibility and provide accountability for performing work and inspections. Records to demonstrate compliance with this document are required.

##### **4.10.2 Records**

###### **4.10.2.1 General**

Each contractor shall prepare and maintain written records as detailed below. Vendor inspection records or mill certificate records will fulfill the requirements of this section for that portion of the required information contained herein.



MIL-STD-2219A  
w/CHANGE 1

**4.10.2.2 Qualification records**

**4.10.2.2.1 Welding procedure qualification**

These records should be as specified by *AWS B2.1*.

**4.10.2.2.2 Welder and welding operator qualification**

These records shall be as required by *AWS D17.1 section 4*.

**4.10.2.2.3 NDE personnel qualification**

Records of personnel qualification shall be maintained in accordance with *AIA/NAS410*.

**4.10.2.3 NDE records**

**4.10.2.3.1 Radiographic inspection**

These records shall be as required by *ASTM-E1742*.

**4.10.2.3.2 Ultrasonic inspection**

These records shall be as required by *SAE-AMS-STD-2154*.

**4.10.2.3.3 Magnetic particle inspection**

These records shall be as required by *ASTM-E1444*.

**4.10.2.3.4 Penetrant inspection**

These records shall be as required by *ASTM-E1417*.

**4.10.2.4 Inspection records**

Each contractor shall ensure that the records, including radiographic films, compiled for his materials, components or weldments are retained for a period of five years for Class A or B welds and one year for Class C welds following acceptance of the weld. They shall be available for review by the cognizant engineering organization upon request.

**4.10.2.5 Workmanship**

Acceptable quality and completeness of workmanship shall be assured by a record of inspection completion as the work progresses from prefabrication through completion. The record of workmanship shall be verified by the inspector's signature or assigned code or stamp.

MIL-STD-2219A  
w/CHANGE 1

## 5. DETAILED REQUIREMENTS

A procedure qualification record shall be established for all Class A and B welds. The PQR shall contain all of the relevant information contained in the format example in [Appendix A](#).

### 5.1 Welding consumables

#### 5.1.1 Low hydrogen electrode storage

These covered electrodes shall be procured in hermetically sealed containers. After removal from the container, the electrodes shall be stored in an oven at a temperature to prevent moisture contamination.

##### 5.1.1.1 Exposure

After hermetically sealed containers are opened or after electrodes are removed from drying or storage ovens, the electrode exposure before use shall not exceed the following values:

E70XX	4 hrs
E80XX	2 hrs
E90XX	1 hr
E100XX	½ hr
E110XX	½ hr
E120XX	½ hr

#### 5.1.2 Bare filler metal storage

Bare welding wire and welding rod shall be stored in a clean and dry environment. Heating may be employed if necessary to prevent moisture accumulation.

#### 5.1.3 SAW flux

This flux shall be stored in a clean and-dry area. Unfused SAW flux may be reused.

#### 5.1.4 Identification

Filler metal and flux shall be properly identified.

##### 5.1.4.1 Covered electrodes

Each covered electrode shall have distinguishable color code, type designation, or classification number marking. If markings are destroyed or missing, electrodes shall not be used.

MIL-STD-2219A  
w/CHANGE 1

#### 5.1.4.2 Bare welding wire and welding rod

Each spool or coil shall carry an identifying label and each piece of bare welding rod shall be marked. Marking shall comply with the requirements of *AMS2816*, *AWS A5.01* or other system acceptable to the cognizant engineering organization.

#### 5.1.4.3 SAW flux

Each container shall be labeled by type and size.

#### 5.1.5 Gases

Gases listed in the "Specification" column of [TABLE I](#) shall be used unless the alternate specification is specified by the cognizant engineering organization.

### 5.2 Manufacturing controls

#### 5.2.1 Joint configuration

Joint design and dimensions shall be as specified on the drawing or in the welding procedure. The resulting weld shall meet the applicable requirements of [5.4.3](#) and [5.4.3.5](#).

**TABLE I. Gases (minimum requirements).**

Gases	Specifications	Alternate Specifications
Argon	<i>MIL-A-18455</i>	<i>CGA G11.1</i>
Helium	<i>BB-H-1168</i>	<i>CGA G9.1</i>
Oxygen	<i>BB-O-925, Type I or II</i>	<i>CGA G4.3</i>
Nitrogen	<i>A-A-59503, Type I or II, Class 1, Grade B</i>	<i>CGA G10.1</i>
Hydrogen	<i>BB-H-886, Type I or II</i>	<i>CGA G5.3</i>
Acetylene	<i>BB-A-106, Grade B</i>	<i>CGA G1.1</i>
Carbon Dioxide	<i>BB-C-101, Grade B</i>	<i>CGA G6.2</i>
Gas Mixtures	The purity of the gases in the mixture shall be as specified for the individual gases listed above	

MIL-STD-2219A  
w/CHANGE 1

## 5.2.2 Preweld joint preparation

### 5.2.2.1 Surface finish of fusion faces

Surface finish of fusion faces for Class A welds shall be defined in the welding procedure or on the drawing. Fusion faces shall be free of cracks, laminations and burrs.

### 5.2.2.2 Joint and filler metal cleanliness

All faying surfaces shall be free from slag, visible surface oxides, scale, protective finishes, oils, grease, dirt, and other foreign materials. Solvent cleaning is allowed for degreasing base metal and bare filler metal. Caution: Chlorinated hydrocarbon solvents shall not be used in pre-weld cleaning of titanium parts. Wire brushing, chemical cleaning, filing or scraping may be used as required to remove oxide or other contaminants from the fusion faces and faying surfaces. The cleaned area shall not be contaminated. Only clean lint-free gloves shall be used when handling cleaned titanium filler metal and joint surfaces.

### 5.2.3 Pre-weld joint fit-up

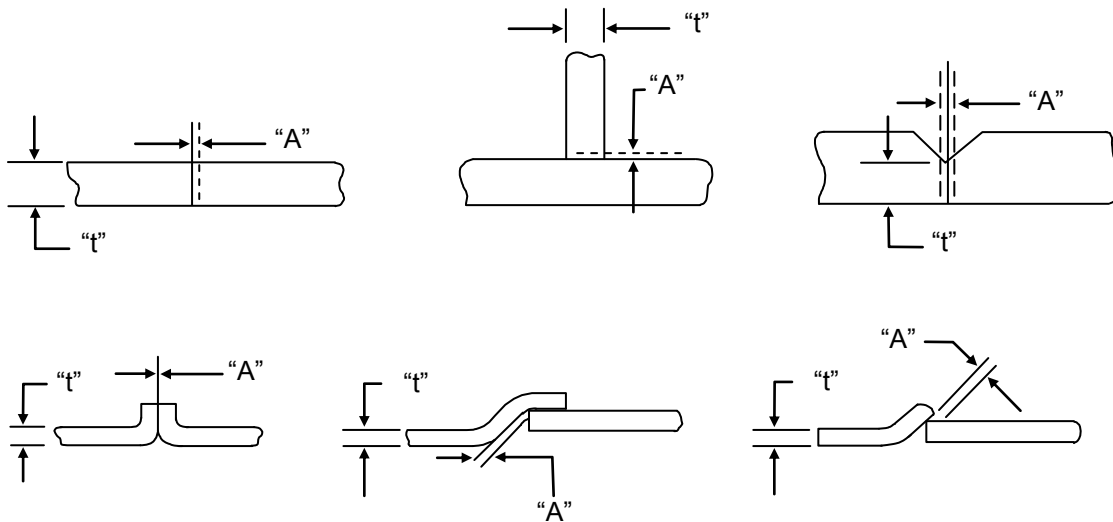
If not stated on the engineering drawing or in the weld procedure, joint fit-up for all classes of welds shall conform to [TABLE II](#) and [FIGURE 1](#), [FIGURE 2](#) and [FIGURE 3](#), as applicable. Where a specified fit-up gap is given as part of a weld procedure and no tolerances are given, the allowances of [TABLE II](#) may be added. Magnesium butt joints welded from one side only may be back beveled, as shown in [FIGURE 4](#).

**TABLE II. Maximum root opening.**

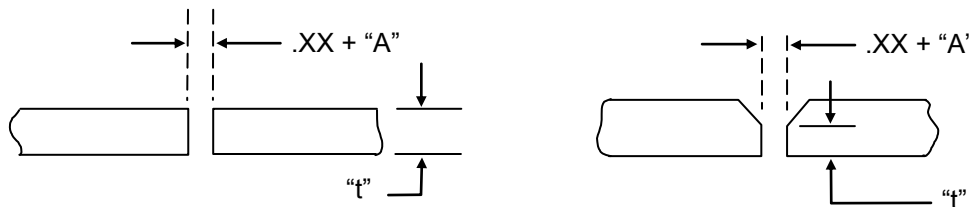
PROCESS	OFW, SMAW, GTAW, GMAW, PAW Manual	GTAW, GMAW, PAW, FCAW Machine
MAXIMUM ROOT OPENING	½ "T" or 0.060 inch whichever is less	¼ "T" or 0.030 inch whichever is less

Where "T" is thickness of the thinner member.

MIL-STD-2219A  
w/CHANGE 1

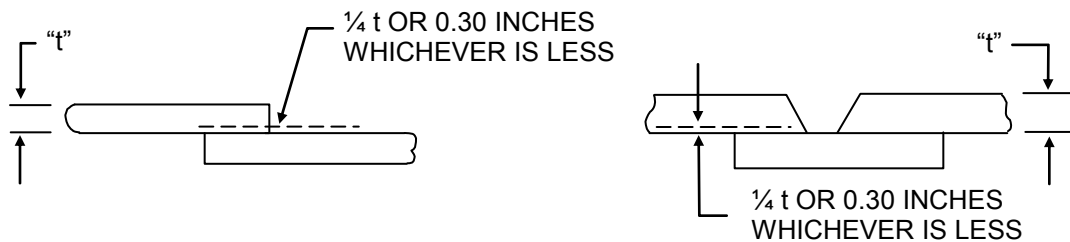


NO ROOT OPENING (METAL TO METAL FIT)



SPECIFIC ROOT OPENING (.XX) AS SPECIFIED ON THE DRAWING

**FIGURE 1. Variations of root openings.**

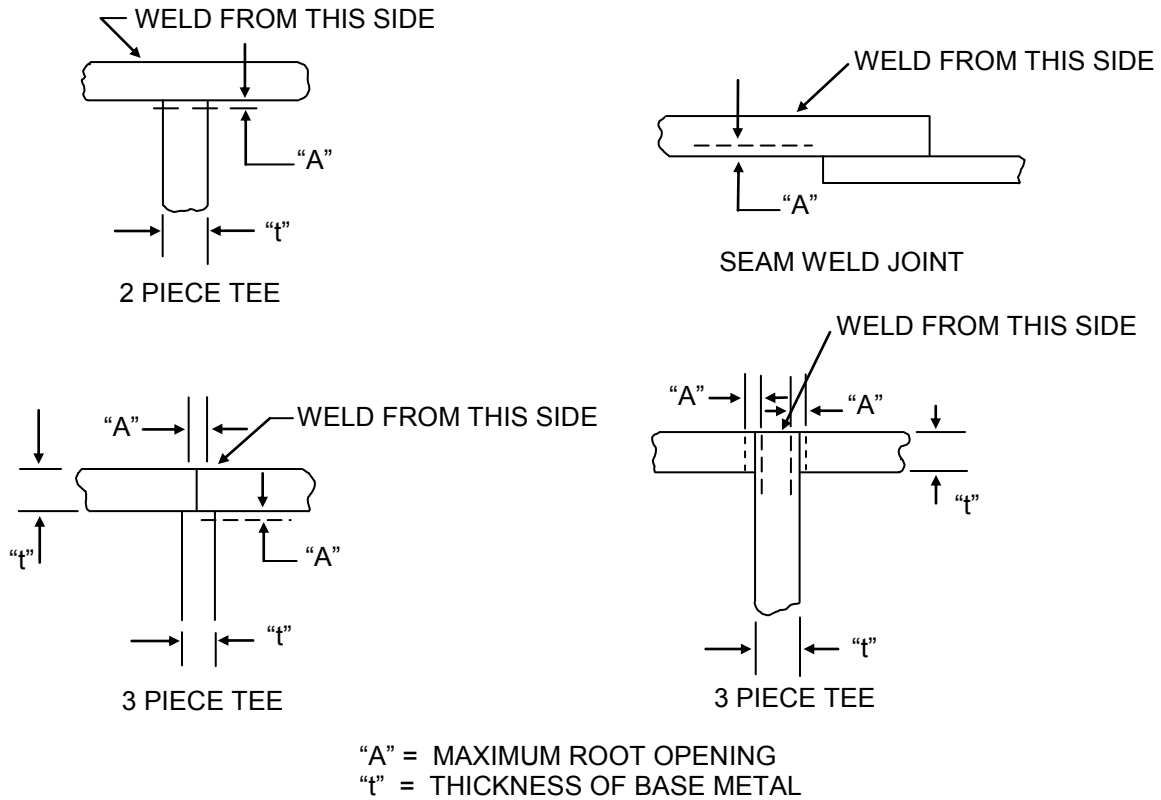


LAP JOINT

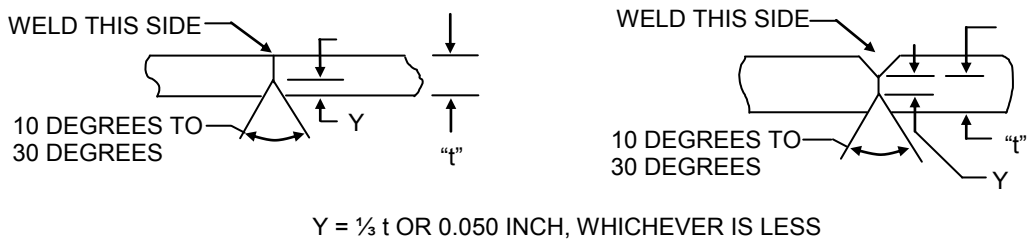
BACKING STRIP

**FIGURE 2. Allowable separation.**

MIL-STD-2219A  
w/CHANGE 1



**FIGURE 3. Two and three piece tee and seam weld joints.**



**FIGURE 4. Back beveling magnesium.**

MIL-STD-2219A  
w/CHANGE 1

## 5.3 Welding requirements

### 5.3.1 Identification

Each welder/welding operator shall identify his work by interim marking, adjacent to the weld joint or by marking the sign-off sheet of 4.9. The interim identification shall remain adjacent to or with the weld until final weld inspection.

### 5.3.2 Qualified weld settings

A welding procedure specification (WPS) shall be established for each production Class A and B weld (see [Appendix B](#)). The WPS shall be based on the appropriate PQR. Qualified weld settings established in accordance with section 4 are required for machine welding of Class A and B welds. Qualified weld settings are required for manual welding of Class A and B welds. Allowable variations from the established weld settings for machine welding are acceptable if within  $\pm 10\%$ . If meter readings are used, the variation shall be based on the mean reading.

### 5.3.3 Reproducibility of qualified weld settings

#### 5.3.3.1 When a sample is required

A sample shall be made to demonstrate the reproducibility of the weld settings whenever one of the following situations occurs:

- a. A change in the location of the welding equipment (machine welding only).
- b. A change in the welding power supply (machine welding only).
- c. The installation of electrical components which would affect welding parameters.
- d. A change in tooling which will affect heat dissipation rate from the weld area of the joint or which will affect the shielding gas effectiveness.

#### 5.3.3.2 Sample preparation

The reproducibility sample shall consist of a simulated or actual production joint (if production joint will be less than 10 inches in length) or 10 inches of a simulated or actual joint (where the production item requires at least a 10 inch long weld). The reproducibility sample shall meet the quality requirements of the production item.

### 5.3.4 Requalification of weld settings

Requalification of the affected machine settings shall be required when:

MIL-STD-2219A  
w/CHANGE 1

- a. The qualified settings reproducibility sample is not able to meet the requirements of this document.
- b. The qualified weld settings will not provide acceptable product weld quality.

### 5.3.5 Welding procedures

#### 5.3.5.1 Filler metal

The filler metal alloy shall be specified on the drawing or in the weld procedure.

#### 5.3.5.2 Preheating, interpass temperature control and postheating

Preheating, interpass temperature control and postheating when used in conjunction with a qualified setting shall become a part of the qualified weld setting procedure. Preheating, interpass temperature control and postheating is required for in-process correction, when it is required for, the original weld. Torch heating with a gentle, soot-free, neutral flame is allowed. Oxy-acetylene torch heating is not allowed for titanium or magnesium. Localized heating is allowed. Temperature gradients shall be wide spread. The preheat, interpass and postheat temperatures specified herein apply to the weld joint area. Maximum temperatures apply to the entire part. The use of furnaces, heat lamps, resistance elements, induction heating and other devices with pyrometric controls is preferred over torch heating.

##### 5.3.5.2.1 Magnesium castings

Preheating and interpass temperature control is recommended as follows:

- a. F condition — 450° to 500°F
- b. T condition — 250° to 300°F

Recommended for sections greater than 0.125 inch thick.

##### 5.3.5.2.2 Steels

Preheating and interpass temperature control should be exercised with steels that are susceptible to cracking. Some examples of steels which are susceptible to cracking are:

1040	4137	4335	4340	8635	8740	AMS6407
4135	4140	4335M	4340M	8735	4330M	



MIL-STD-2219A  
w/CHANGE 1

#### **5.3.5.2.3 Other base metals**

Preheat and interpass temperature control is optional for all other base metals not identified in [5.3.5.2.1](#) and [5.3.5.2.2](#). If preheat and interpass temperature control are required, they shall be authorized by the cognizant engineering organization and detailed on the drawing.

#### **5.3.5.3 Tackwelds**

If filler metal is used for tacking, use the same filler metal alloy as specified for the weld. The length and size of tack welds shall be limited to a size that will be melted by the subsequent weld pass.

#### **5.3.5.4 Fixtures**

Fixtures, backing materials and hold-down bars shall be kept clean and free of contaminants during use.

#### **5.3.5.5 Weld start and run-off tabs**

Weld start and run-off tabs when used shall be composed of the same alloy as the detail parts, and shall be welded with the same filler metal as required by the part.

#### **5.3.5.6 Weld shielding for GTAW, GMAW, and PAW**

The weld shall be protected from oxidation during welding. Completed weldments including heat affected surfaces shall comply with the requirements of [5.3.5.8](#) and [5.4.3.5](#). Shielding gas and material combinations shall be as noted in [TABLE III](#) unless otherwise specified in the contract or on the drawing.

#### **5.3.5.7 Cleaning between welds**

Prior to depositing each pass of a noncontinuous multipass weld or deposition of a root pass on the side opposite the original weld, the welder or welding operator shall visually examine for contamination and defects. Contamination and defects, other than discoloration for titanium alloys, shall be removed by wire brushing, machining, rotary filing, drilling, grinding, sanding or scouring. Removal of unacceptable discoloration for titanium alloys, as specified in [5.4.4.3](#), shall be accomplished by any of the following methods: scraping, scouring, machining, rotary filing, wire brushing or by cleaning in accordance with *ASTM-B600*. Cleaning titanium with chlorinated solvents or methyl alcohol is prohibited.

MIL-STD-2219A  
w/CHANGE 1**TABLE III. Shielding gas and material combinations.**

Material	Gas <u>1/</u>						
	Argon	Helium	Argon Helium	Argon <u>2/</u> Oxygen	Argon Hydrogen	Nitrogen	Carbon Dioxide
Aluminum	A	A	A				
Cobalt	A	A	A		A		
Copper	A	A	A				
Magnesium	A	A	A				
Nickel	A	A	A				
CRES Steels	A	A	A	A		Backing only	
Plain Carbon Steels	A	A	A	A			<u>3/</u>
Low alloy Steels	A	A	A	A			
Titanium	A	A	A				

## Notes:

A = Allowed

1/ Gas compositions and mixtures shall comply with [TABLE I](#).2/ 8 percent oxygen maximum.3/ Only permitted on plain carbon steel with a maximum of 0.25 percent nominal carbon.**5.3.5.8 Post weld cleaning**

Except as noted in [5.4.4.3](#) and [5.4.4.4](#), completed weldments shall be free of visible oxides, flux, spatter, scale, slag, or other foreign matter. Cleaning, if required, shall be in accordance with [5.2.2.2](#). Welding flux shall be completely removed by appropriate methods. Removal of material during the cleaning operation shall not exceed the allowed tolerances of the end product specification.

**5.3.6 Stress relief**

When required, stress relief of weldments shall be specified in the welding procedure or the drawing.

MIL-STD-2219A  
w/CHANGE 1

## 5.4 Inspection and acceptance criteria.

### 5.4.1 General

All welds shall be 100% visually inspected by a qualified inspector.

### 5.4.2 Nondestructive inspection

#### 5.4.2.1 Penetrant Inspection

All Class A and B welds shall be inspected in accordance with *ASTM-E1417*, unless magnetic particle inspection is performed. Class C weld shall be inspected when specified on the drawing or in the contract.

#### 5.4.2.2 Magnetic particle inspection

All Class A and B welds of ferromagnetic materials shall be inspected in accordance with *ASTM-E1444* unless penetrant inspection is performed. Class C welds shall be inspected when specified on the drawing or in the contract.

#### 5.4.2.3 Radiographic inspection

All Class A groove welds (except for fillet welds) or butt joints shall be inspected in accordance with *ASTM-E1742*. Class B and C welds shall be inspected radiographically per *ASTM-E1742* when specified on the drawing or in the contract. Ultrasonic inspection (see [5.4.2.4](#)) may be used in lieu of radiographic inspection when specified on the drawing or in the contract.

#### 5.4.2.4 Ultrasonic inspection

Ultrasonic inspection in accordance with *SAE-AMS-STD-2154* shall be performed when specified on the drawing or in the contract.

#### 5.4.2.5 Extent of inspection

Unless otherwise specified in [5.4.2.1](#), [5.4.2.2](#), or [5.4.2.3](#), nondestructive inspection shall be performed within the following parameters to ensure that the requirements of [5.4.3.5](#) are met:

- a. Class B welds – *MIL-STD-1916*, limiting quality of 10% defective for a probability of 10%.
- b. Class C welds – no requirements.

MIL-STD-2219A  
w/CHANGE 1**5.4.3 Weld configuration****5.4.3.1 Weld reinforcement and weld width**

Weld reinforcement shall fair smoothly with itself and the base metal. When machine welding is required by drawing callout, weld reinforcement "R" for Class A and B groove welds shall not exceed the limits of  $\frac{1}{3}$  T or 0.030 inch, whichever is the greater, for material thicknesses 0.375 inches and under. For material greater than 0.375 inches the maximum reinforcement shall be 0.125 inch. When machine welding is not required by drawing callout, requirement for weld reinforcement "R" for Class A and B welds shall not exceed the limits as follows:

- a. For material up to 0.125 inch thick – 1 T maximum.
- b. For material 0.125 inch to 0.510 inch thick –  $\frac{1}{3}$  T or 0.100 inch whichever is greater.
- c. For material 0.510 inch and thicker – 0.170 inch maximum.

Typical examples of weld reinforcement profiles are indicated in [FIGURE 5](#). Width of each bead of a single or multi-pass weld shall not exceed 0.625 inches for GTAW, GMAW, FCAW, SAW and PAW. For SMAW width of weave bead shall not exceed  $2\frac{1}{2}$  times the core diameter of electrode being used.

**5.4.3.2 Weld penetration**

Groove welds in joints welded from only one side without a backing strip shall show complete joint penetration as evidenced by the absence of a joint line on the other side which exceeds the discontinuity limit for incomplete penetration in [TABLE V](#) (see [FIGURE 6a](#)). The backing strip, when required, shall be penetrated so as to ensure complete joint penetration and fusion of the root edges of the joint (see [FIGURE 6b](#)).

**5.4.3.3 Melt-through**

Where the welding symbol requires full penetration; overlap, flare, flange or corner joints shall be melted down so that complete joint penetration is obtained, and the resulting weld shows no evidence that the details were joggled, flared or flanged. Typical overlap, flare, edge-flange, and corner welds are shown in [FIGURE 7](#). Maximum root side reinforcement is as follows:

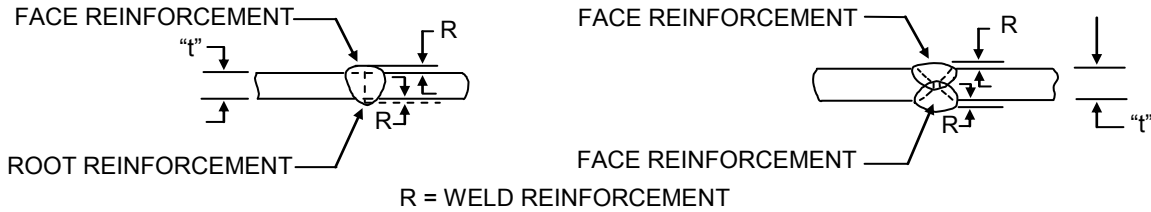
- a. For material up to 0.125 inch thick – 1 T maximum.
- b. For material 0.125 inch to 0.510 inch thick –  $\frac{1}{3}$  T or 0.100 inch whichever is greater.

MIL-STD-2219A  
w/CHANGE 1

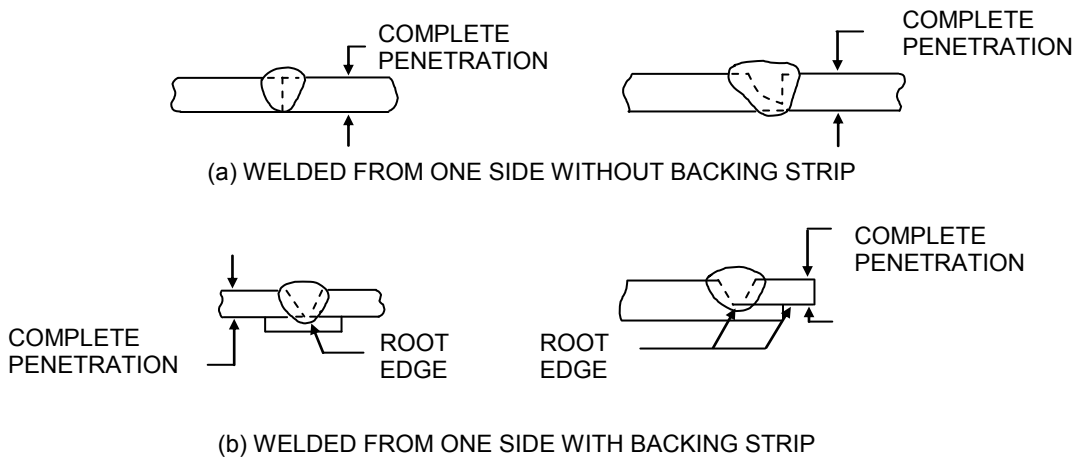
c. For material 0.510 inch and thicker – 0.170 inch maximum.

**5.4.3.4 Two and three piece tee joints**

Melt-thru weld dimensions for two and three piece tee joints are as shown in **FIGURE 8**.

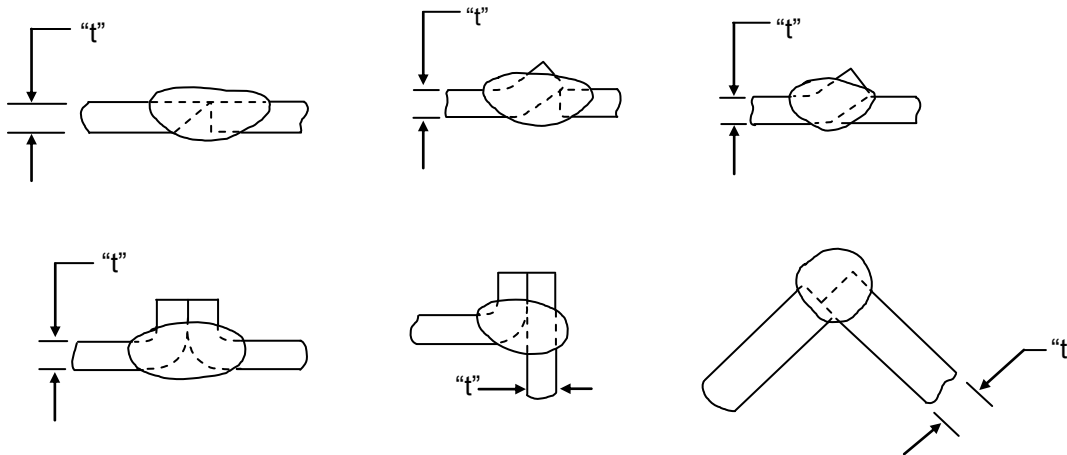


**FIGURE 5. Weld reinforcement profiles.**

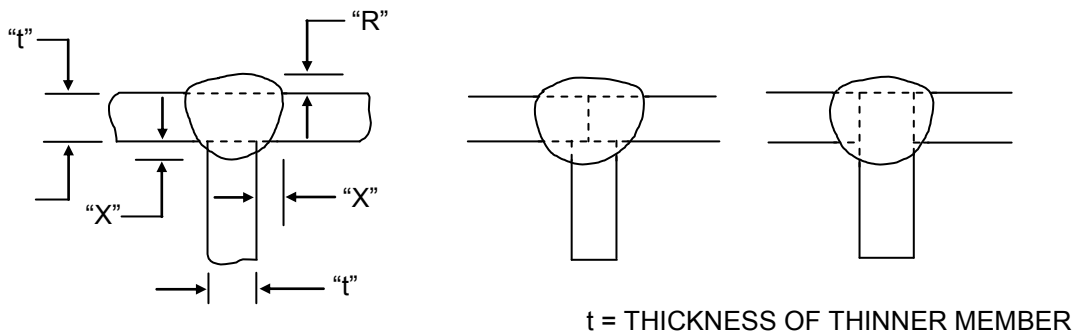


**FIGURE 6. Penetration profiles.**

MIL-STD-2219A  
w/CHANGE 1



**FIGURE 7. Melt through welds.**



(DIMENSIONS ARE TYPICAL)

- MINIMUM "x" DIMENSIONS ARE  $\frac{1}{2} t$  OR 0.015 INCH, WHICHEVER IS GREATER.
- MAXIMUM "x" DIMENSIONS ARE  $2 \frac{1}{2} t$  OR 0.187 INCH, WHICHEVER IS LESS.
- WELD REINFORCEMENT "R" FOR CLASS A WELDS SHALL BE IN ACCORDANCE WITH 5.4.3.3.

**FIGURE 8. Melt through tee joints.**

MIL-STD-2219A  
w/CHANGE 1

### 5.4.3.5 Fillet welds

Fillet weld size shall be as specified in the drawing and represents the minimum weld size (see [TABLE IV](#)).

**TABLE IV. Minimum fillet weld sizes.**

Material Thickness "T"	Weld Bead Size "S" <sup>1/</sup>		Material Thickness "T"	Weld Bead Size "S" <sup>1/</sup>	
	Double side <sup>2/</sup>	Single side <sup>3/</sup>		Double side <sup>2/</sup>	Single side <sup>3/</sup>
0.010 – 0.025	0.02	0.04	0.126 – 0.156	0.12	0.23
0.026 – 0.050	0.04	0.075	0.157 – 0.188	0.14	0.28
0.051 – 0.078	0.06	0.12	0.189 – 0.250	0.19	0.38
0.079 – 0.090	0.07	0.14	0.251 – 0.500	0.38	0.75
0.091 – 0.125	0.09	0.19			

Notes:

- <sup>1/</sup> Weld bead size is determined by the thinner member.
- <sup>2/</sup> Double side welds are welds made on both sides of the joint.
- <sup>3/</sup> Single side welds are welds made from only one side of the joint.

### 5.4.4 Weld quality

#### 5.4.4.1 General

Cracks, incomplete fusion and overlap are not acceptable in any class of weld. Two or more adjacent surface discontinuities shall be treated as one when the space between them is less than the dimension of the smallest discontinuity. The dimension of any discontinuity shall be defined by its largest dimension. Interconnecting discontinuities shall be considered as a single discontinuity. Limits of discontinuity when specified in terms of percentage of thickness "T" shall be based on thinner member of the joints. In the case of weldments with variations in cross section along the joint, "T" shall be considered to be the minimum thickness at the specific discontinuity location. Arc strikes, arc burns from loose electrical connections and gouge marks on the base metal of the finished weldment are unacceptable for Class A and B welds. Welds made from one side only under 0.125 inch thick may have the root surface faired in by using a

MIL-STD-2219A  
w/CHANGE 1

cosmetic weld pass or by grinding, provided that complete penetration was obtained in the original weld. Preferential arc erosion of the heat affected zone on aluminum welds may be removed by lightly sanding or wire brushing followed by etching as specified in *ASTM-E1417* prior to inspection.

#### 5.4.4.2 Discontinuity limits

Discontinuities shall not exceed the limits of [TABLE V](#).

#### 5.4.4.3 Discoloration of titanium

Contamination resulting in discoloration of weld bead and the adjacent area is not acceptable except as follows:

- a. For welds of all classes including HAZ, bright silver color is acceptable.
- b. For Class A welds including zones up to 0.030 inches beyond the weld edges, silver to light straw color is acceptable but must be removed if additional welding is performed. Violet to blue or gray color contamination shall be cause for rejection of the weldment.
- c. For Class B and Class C welds including zones out to 0.030 inches beyond the weld edges, silver to violet color is acceptable but must be removed if additional welding is performed. Blue color contamination is not acceptable if additional welding is performed. Blue color contamination is acceptable for the finished weld but must be removed. Gray color contamination shall be cause for rejection of the weldment.
- d. Discoloration, except for gray color, is allowed in the base metal beyond the 0.030 limit, except that blue discoloration shall be removed.
- e. Removal of superficial discoloration shall be in accordance with [5.3.5.8](#).
- f. Gray color contamination shall be cause for rejection unless it can be conclusively proven that embrittlement has not occurred, such as by microhardness test or other direct tests.

#### 5.4.4.4 Discoloration of 300-series corrosion resistant steel and carbon and low alloy steels

Tightly adhering iridescent temper films and light straw/tan discoloration on the finished weldment shall not be cause for rejection.



MIL-STD-2219A  
w/CHANGE 1

**TABLE V. Discontinuity limits.**

IMPERFECTION	CLASS OF WELDS		
	A	B	C
<b>SURFACE POROSITY:</b>			
Individual size maximum	0.25 T or 0.030 inch whichever is less	0.33 T or 0.060 inch whichever is less	0.50 T or 0.090 inch whichever is less
Spacing – minimum	8 times the size of the larger adjacent imperfection	4 times the size of the larger adjacent imperfection	2 times the size of the larger adjacent imperfection
Accumulated length in any 3 inches of weld – maximum	1 T or 0.12 inch whichever is less	1.33 T or 0.24 inch whichever is less	2 T or 0.36 inch whichever is less
<b>UNDERCUT:</b>			
For full length of weld – maximum depth	0.002 inch	0.015 T or 0.002 inch whichever is greater	0.025 T or 0.002 inch whichever is greater
Individual defect maximum depth	0.07 T or 0.030 inch whichever is less	0.10 T or 0.050 inch whichever is less	0.20 T or 0.070 inch whichever is less
Accumulated length in any 3 inches of weld – maximum	0.20 inch	0.60 inch	1.00 inch
<b>UNDERFILL AND/OR CONCAVITY:</b>			
For full length of weld – maximum depth	0.005 inch	0.015 T or 0.005 inch whichever is greater	0.025 T or 0.005 inch whichever is greater
Individual defect maximum depth	0.07 T or 0.030 inch whichever is less	0.10 T or 0.050 inch whichever is less	0.20 T or 0.070 inch whichever is less
Accumulated length in any 3 inches of weld – maximum	0.20 inch	0.60 inch	1.00 inch
<b>SUBSURFACE POROSITY AND INCLUSIONS:</b>			
Individual size maximum	0.33 T or 0.060 inch whichever is less	0.50 T or 0.090 inch whichever is less	Not applicable
Spacing – minimum	4 times the size of the larger adjacent imperfection	2 times the size of the larger adjacent imperfection	Not applicable
Accumulated length in any 3 inches of weld – maximum	1.33 T or 0.24 inch whichever is less	2 T or 0.36 inch whichever is less	Not applicable
<b>INCOMPLETE PENETRATION:</b>			
Maximum depth	none	0.20 T or 0.05 inch whichever is less	0.20 T or 0.05 inch whichever is less
<b>CRATERS:</b>			
Maximum depth	0.20 T or 0.03 inch whichever is less	0.20 T or 0.05 inch whichever is less	0.20 T or 0.05 inch whichever is less
Maximum length	1 T	1 T	2 T
<b>CRACKS:</b>			
	None	None	None
<b>COLD SHUT: 1/</b>	1 T or 0.1 inch 2/ whichever is lesser	1 T maximum length	2 T maximum length

MIL-STD-2219A  
w/CHANGE 1

TABLE V. Discontinuity limits - Continued

## Notes:

- 1/ If the defects exhibit sharp radii, sharp termination, or are cracklike, they shall be removed by grinding. If the depression is not larger than permitted, they need not be rewelded.
- 2/ Where possible to determine by metal removal, the depth of cold shut shall not cause joint thickness to be less than the thinner material being welded.

**5.4.5 Disposition of unacceptable welds**

Welds not meeting the requirements of 5.4.3 and 5.4.3.5 shall be rejected or in-process corrected as specified below. Imperfections that will be removed by subsequent machining shall not be cause for rejection. Removal of unacceptable weld metal is allowed provided the weld size and minimum base metal thickness requirements are met.

**5.4.5.1 Rejections**

Any defective weldment which has gone through a subsequent manufacturing operation that affects the metallurgical characteristics (other than tempering or stress relieving of martensitic steels) or that cannot be rewelded without affecting final metallurgical or surface coating characteristics shall be referred to the Material Review Board. Any weldment with cracks in the base metal shall be rejected.

**5.4.5.2 In-process correction**

In-process correction is any corrective action taken by the welder prior to the weldment departing the welding shop and prior to any inspection. The in-process correction history shall be part of the paperwork accompanying the weld. Rewelding shall be accomplished by the same process and filler material used to make the original weld. Manual GTAW process may be used at shop option for all processes. Corrected welds shall meet the requirements of the original welds.

**5.4.5.2.1 For Class A welds**

Surface and subsurface imperfections within the weld metal area (not extending into the HAZ or base metal) may be repaired one time as defined below:

MIL-STD-2219A  
w/CHANGE 1

- a. Weld undercut, underfill or craters may be corrected by depositing a weld bead fairing in the original weld and the base metal.
- b. Unacceptable overlap, weld drop-through and other protruding imperfections may be removed by dressing the weld deposit.

If a satisfactory correction is not achieved by the first repair, the weldment shall be referred to the Material Review Board.

**5.4.5.3 Class B welds**

Weld imperfections as defined in [5.4.5.2.1](#) may be repaired twice. If a satisfactory weld is not achieved by the second repair, the weldment shall be referred to the Material Review Board.

**5.4.5.4 Class C welds**

Repairs may be made by manufacturing as required to meet the quality requirements of Class C welds. Records are not required.

MIL-STD-2219A  
w/CHANGE 1

## 6. NOTES

(This section contains information of a general or explanatory nature that may be helpful, but is not mandatory.)

### 6.1 Intended use

The intended use of *MIL-STD-2219* is to standardize the requirements for fusion welding of metals used for aerospace flight hardware.

### 6.2 Acquisition requirements

Acquisition documents should specify the following:

- a. Title, number, and date of the standard.

### 6.3 Subject term (keyword) listing

Aerospace  
Aluminum  
Base metal  
Cobalt base alloys  
Electrodes  
Filler metal  
Flux  
Inspections  
Nickel base alloys  
Nondestructive examinations  
Radiography  
Rods and wire  
Steel  
Titanium  
Ultrasonic  
Welders  
Welding  
Welding operators  
Welding rod  
Welding wire

### 6.4 Clarification and cross reference of classes

The classes contained in this document are clarified in [3.3](#).

MIL-STD-2219A  
w/CHANGE 1

### **6.5 Welding safety**

Fumes generated during welding certain metals, in particular magnesium, present a health hazard. *ANSI-Z49.1* should be reviewed regarding welding safety precautions.

### **6.6 Cognizant engineering organization**

The cognizant engineering organization is defined in 3.7 as the engineering organization responsible for the design of the welded assembly. This definition does not limit the cognizant engineering organization to the design personnel but should include the appropriate engineering personnel in the organization's material and process group, stress analysis group, welding shop and quality control as appropriate to the particular weldment.

#### **6.6.1 Examples**

The following examples are provided to add clarity.

- a. Company ABC is the design organization for a weldment. Welding is performed both in-house and at a subcontractor. Any deviations from the design of the weldment must be approved by the cognizant engineering personnel in company ABC.
- b. The Government is purchasing a weldment from company XYZ and has generated the design. Whether the welding is performed by XYZ or a subcontractor to XYZ, the cognizant engineering organization is the Government.
- c. The Government has been purchasing a weldment from company ABC using a design generated by company ABC. The Government wishes to use a second source for the weldment. The Government is the cognizant engineering organization for the second source; while company ABC is also the cognizant engineering organization with respect to its in-house welding shop or its subcontractors.

### **6.7 Changes from previous issue**

The margins of this standard are marked with vertical lines to indicate where changes from the previous issue were made. This was done as a convenience only and the Government assumes no liability whatsoever for any inaccuracies in these notations. Bidders and contractors are cautioned to evaluate the requirements of this document based on the entire content irrespective of the marginal notations and relationship to the last previous issue.

MIL-STD-2219A  
w/CHANGE 1

This page intentionally left blank.

MIL-STD-2219A  
w/CHANGE 1

**APPENDIX A**

**Procedure Qualification Record (PQR)**

PQR # \_\_\_\_\_ DATE: \_\_\_\_\_

Welding Procedure Specification # (If Applicable) \_\_\_\_\_

Process(es): \_\_\_\_\_

Joint/Weldment Design

Welding Sequence

**Materials:**

Base metals

Group#: \_\_\_\_\_ joined to \_\_\_\_\_  
 Alloy: \_\_\_\_\_ joined to \_\_\_\_\_  
 HT condition: \_\_\_\_\_ joined to \_\_\_\_\_  
 Thickness: \_\_\_\_\_ joined to \_\_\_\_\_

**Filler**

F-#: \_\_\_\_\_  
 AWS/SAE class: \_\_\_\_\_  
 Diameter: \_\_\_\_\_  
 Shielding Gas: Primary: \_\_\_\_\_  
 Secondary or backup: \_\_\_\_\_  
 Flow rate: \_\_\_\_\_ (Units)  
 GTAW Electrode type: \_\_\_\_\_  
 Tip Angle: \_\_\_\_\_  
 Backgouging: yes \_\_\_\_\_ no \_\_\_\_\_

**Cleaning method**

Specification #: \_\_\_\_\_  
 Deoxidation  
 Method \_\_\_\_\_ Time \_\_\_\_\_  
 Degreasing  
 Method \_\_\_\_\_ Time \_\_\_\_\_

Pass #	Process	A	V	T/S

Welding power source \_\_\_\_\_

Bead type: Weave \_\_\_\_\_ Stringer \_\_\_\_\_  
 Current: AC \_\_\_\_\_ DC \_\_\_\_\_ Square W \_\_\_\_\_  
 Polarity: \_\_\_\_\_ Square W \_\_\_\_\_ % +  
 \_\_\_\_\_ % -

Joint Position: \_\_\_ G \_\_\_ F

**Preheat**

Temperature (C): \_\_\_\_\_  
 Interpass Max (C): \_\_\_\_\_

**Post weld HT**

Spec # and section: \_\_\_\_\_  
 Time from welding: \_\_\_\_\_  
 Sequence: Solution Temp/Time \_\_\_\_\_  
 Quench (media and temp): \_\_\_\_\_

Temper/age: \_\_\_\_\_  
 Hardness/conductivity: \_\_\_\_\_

MIL-STD-2219A  
w/CHANGE 1  
APPENDIX A

Procedure Qualification Record (PQR) - Continued

Mechanical/Physical testing

Weld type F__ G__	Location in weld	Test method (ASTM #)	# of test	Results	Failure location	Type of failure
Tensile						
SCC						
Bend						
Fatigue						

Metallographic examination

	Location in weld	# samples	Results:
Undercut			
Porosity			
Cracking			
Penetration			
Fusion			
Drop through			

Visual inspection: \_\_\_ pass \_\_\_ fail Comments: \_\_\_\_\_

Welders Name: \_\_\_\_\_ Stamp #: \_\_\_\_\_

Test performed by: \_\_\_\_\_

Signed: \_\_\_\_\_ (M&P) Title: \_\_\_\_\_  
 \_\_\_\_\_ (Quality) Title: \_\_\_\_\_  
 \_\_\_\_\_ (ENG) Title: \_\_\_\_\_

Date: \_\_\_\_\_



MIL-STD-2219A  
w/CHANGE 1

**APPENDIX B**

**Welding Procedure Specification (WPS)**

WPS # \_\_\_\_\_ Revision \_\_\_\_\_

Date: \_\_\_\_\_

PQR # (All that apply) \_\_\_\_\_

**Materials:**

**Base metals**

Group#: \_\_\_\_\_ joined to \_\_\_\_\_  
Alloy: \_\_\_\_\_ joined to \_\_\_\_\_  
HT Condition: \_\_\_\_\_ joined to \_\_\_\_\_  
Thickness: \_\_\_\_\_ joined to \_\_\_\_\_

**Fixture/Jigs:**

ID # \_\_\_\_\_ Location \_\_\_\_\_  
Last inspected \_\_\_\_\_ Cleaned: \_\_\_\_\_

**Filler/Shielding**

F-#: \_\_\_\_\_  
AWS/SAE class: \_\_\_\_\_  
Diameter: \_\_\_\_\_ Cold/Hot \_\_\_\_\_  
GTAW Electrode Type: \_\_\_\_\_  
Tip Angle: \_\_\_\_\_  
Shielding Gas: Primary: \_\_\_\_\_

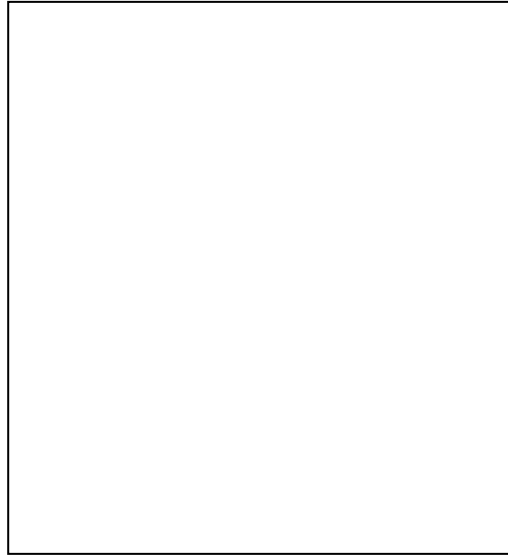
Secondary or Backup: \_\_\_\_\_  
Flow Rate: \_\_\_\_\_ (Units)

Cleaning Method  
Specification #: \_\_\_\_\_  
Deoxidation Method \_\_\_\_\_ Time \_\_\_\_\_  
Degreasing Method \_\_\_\_\_ Time \_\_\_\_\_  
Interpass Cleaning Technique: \_\_\_\_\_

**Preheat**

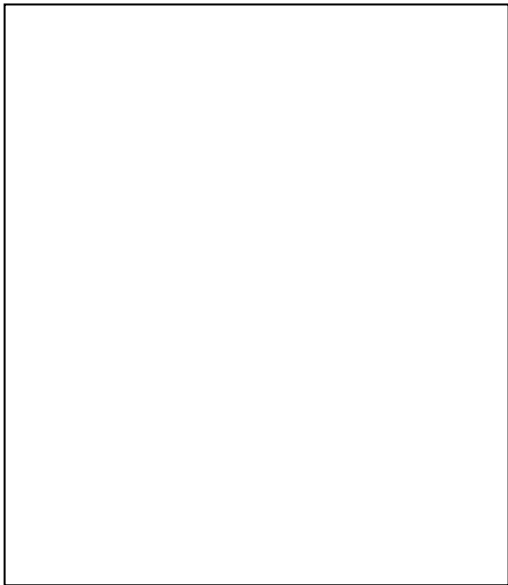
Temperature (C): \_\_\_\_\_ Method: \_\_\_\_\_  
Interpass Max (C): \_\_\_\_\_ Method: \_\_\_\_\_

Joint/Weldment Sketch



Joint Position: \_\_G \_\_F

Locate Tacks:



Welding Sequence Sketch

MIL-STD-2219A  
w/CHANGE 1  
APPENDIX B

Welding Procedure Specification (WPS) - Continued

Welding power source \_\_\_\_\_

Current: AC \_\_\_\_\_ DC \_\_\_\_\_ Square W \_\_\_\_\_

Polarity: \_\_\_\_\_

Square W Amps \_\_\_\_\_ + \_\_\_\_\_ - Time \_\_\_\_\_ + \_\_\_\_\_ -

(EB) only KVA \_\_\_\_\_ Spot size \_\_\_\_\_ T/S \_\_\_\_\_

**Technique:**

Bead type: Weave \_\_\_\_\_ Stringer \_\_\_\_\_

Keyhole: \_\_\_\_\_

Orifice size: \_\_\_\_\_

Electrode Extension: \_\_\_\_\_

**Tacking**

Location and number: \_\_\_\_\_

Length: \_\_\_\_\_

Process used: \_\_\_\_\_

Pass #	Process	Amps (KVA)*	Volts (Spot size)*	Travel speed

\* EB welding

MIL-STD-2219A  
w/CHANGE 1

**CONCLUDING MATERIAL**

Custodians:

Army – AV  
Navy – AS  
Air Force – 11

Preparing Activity:

Air Force – 11

(Project THJM-2008-002)

Review activities:

Army – MI, MR  
Air Force – 70, 71, 84, 99

NOTE: The activities listed above were interested in this document as of the date of this document. Since organizations and responsibilities can change, you should verify the currency of the information above using the ASSIST Online database at <http://assist.daps.dla.mil>.