

METRIC

MIL-STD-2042-2B(SH)
25 July 2002
SUPERSEDING
MIL-STD-2042-2A(SH)
29 September 1997
MIL-STD-2042-2(SH)
7 July 1993

DEPARTMENT OF DEFENSE
STANDARD PRACTICE

FIBER OPTIC CABLE TOPOLOGY INSTALLATION
STANDARD METHODS FOR NAVAL SHIPS
(EQUIPMENT)

(PART 2 OF 7 PARTS)



AMSC N/A

DISTRIBUTION STATEMENT A. Approved for public release; distribution is unlimited.

AREA SESS

MIL-STD-2042-2B(SH)

FOREWORD

1. This Department of Defense Standard Practice is approved for use by the Naval Sea Systems Command, Department of the Navy, and is available for use by all Departments and Agencies of the Department of Defense.

2. Beneficial comments (recommendations, additions, deletions) and any pertinent data which may be of use in improving this document should be addressed to: Department of the Navy, Naval Sea Systems Command, ATTN: SEA 05Q, 1333 Isaac Hull Avenue Southeast, Stop 5160, Washington Navy Yard, DC 20376-5160 by using the self-addressed Standardization Document Improvement Proposal (DD Form 1426) appearing at the end of this document or by letter.

3. This standard practice provides detailed information and guidance to personnel concerned with the installation of fiber optic cable topologies (optical fiber cabling and associated components) on Naval surface ships and submarines. The methods specified herein are not identifiable to any specific ship class or type, but are intended to standardize and minimize variations in installations to enhance the compatibility of the installations on all Naval ships.

4. In order to provide flexibility in the use and update of the installation methods, this standard practice is issued in eight parts; the basic standard practice and seven numbered parts as follows:

- Part 1 Cables
- Part 2 Equipment
- Part 3 Cable Penetrations
- Part 4 Cableways
- Part 5 Connectors and Interconnections
- Part 6 Tests
- Part 7 Pierside Connectivity Cable Assemblies and Interconnection Hardware

MIL-STD-2042-2B(SH)

CONTENTS

<u>PARAGRAPH</u>		<u>PAGE</u>
1.	SCOPE	1
1.1	Scope	1
1.1.1	Applicability	1
2.	APPLICABLE DOCUMENTS	2
2.1	General	2
2.2	Government documents	2
2.2.1	Specifications, standards and handbooks	2
2.2.2	Other government documents	3
2.3	Non-Government publications	3
2.4	Order of precedence	4
3.	DEFINITIONS	5
3.1	General fiber optics terms	5
3.2	Acronyms	5
3.3	Allocated and not used fiber	5
3.4	Allocated and used fiber	5
3.5	Alternate channel	5
3.6	Authorized approval	5
3.7	BOF bundle	5
3.8	BOF cable	5
3.9	BOF fiber	5
3.10	BOF path	5
3.11	BOF tube	5
3.12	BOF tube coupler	5
3.13	BOF tube routing box (TRB)	5
3.14	End user equipment	5
3.15	Fiber optic cable plant	5
3.16	Fiber optic cable topology	6
3.17	Fiber optic interconnection box (FOICB)	6
3.18	Installing activity	6
3.19	Local cable	6
3.20	Minimum bend diameter	6
3.21	Multicable penetrator (MCP)	6
3.22	Non-redundant channel (NRC)	6
3.23	Normal channel	6
3.24	Optical fiber cable	6
3.25	Optical fiber cable component (OFCC)	6
3.26	Outlet box	6
3.27	Spare fiber	6
3.28	Trunk	7
3.29	Trunk cable	7
3.30	Tube furcation unit	7
3.31	Unused fiber	7
4.	GENERAL REQUIREMENTS	8
4.1	Fiber optic equipment installation	8
4.1.1	Interconnection box and tube routing box selection	8
4.1.2	Location	8
4.1.3	Interconnection box mounting	8
4.1.3.1	Bonding, grounding, and shielding	8
4.1.3.2	Holes drilled in beams	9
4.1.3.3	Welding	9
4.1.3.4	Fasteners	9
4.1.3.5	Dissimilar metals	9

MIL-STD-2042-2B(SH)

CONTENTS

<u>PARAGRAPH</u>		<u>PAGE</u>
4.2	Cable entrance to equipment	9
4.2.1	Cable slack	9
4.2.2	Cable forming and shaping	10
4.2.3	Tube forming and shaping	10
4.2.4	Splice assembly and alignment	10
4.2.5	Interconnection organization	10
4.2.5.1	Connector organization	10
4.2.6	Nameplates and marking	11
4.2.6.1	Internal interconnection box marking	11
4.2.6.2	Internal tube routing box marking	11
4.2.7	BOF tube end termination	11
4.3	Safety precautions	12
5.	DETAILED REQUIREMENTS	13
5.1	Fiber optic interconnection equipment installation	13
5.1.1	Non-watertight decks and bulkheads	13
5.1.2	Watertight decks and bulkheads	13
5.1.3	Stanchions	13
5.1.4	Metal joiner bulkheads	13
5.1.5	Expanded metal or wire mesh bulkhead	13
5.1.6	Refrigerated spaces	13
5.1.7	GRP (glass reinforced plastic) bulkheads	13
5.1.8	Locking devices for installations on submarines	14
5.2	Cable entrance to equipment	14
5.2.1	Nylon stuffing tubes	14
5.2.2	Multiple cable penetrator (MCP)	14
5.2.3	Cable clamps	14
5.3	Interconnection organization	14
5.3.1	Conventional cable	14
5.3.2	BOF cable	14
5.4	Splice assembly and alignment	14
5.5	BOF tube furcation unit fabrication	14
5.6	BOF tube furcation unit installation	14
5.7	BOF tube end sealing	14
6.	NOTES	15
6.1	Intended use	15
6.2	Issue of DODISS	15
6.3	Standard method designation	15
6.4	Subject term (key word) listing	15
6.5	Changes from previous issue	15
 <u>METHOD</u>		
2A1	Conventional cable entrance to equipment via nylon stuffing tubes ...	2A1-1
2B1	Conventional cable entrance to equipment via MCP	2B1-1
2C1	Conventional cable and buffered fiber forming and shaping	2C1-1
2D1	Splice assembly and alignment	2D1-1
2E1	BOF tube furcation unit fabrication	2E1-1
2F1	BOF tube furcation unit installation	2F1-1
2G1	BOF cable entrance to equipment via nylon stuffing tubes	2G1-1
2H1	BOF cable entrance to equipment via MCP	2H1-1
2I1	BOF cable forming, routing, and shaping within tube routing boxes ...	2I1-1

MIL-STD-2042-2B(SH)

CONTENTS

<u>METHOD</u>		<u>PAGE</u>
2I2	BOF cable forming, routing, and shaping within interconnection boxes	2I2-1
2J1	BOF tube end sealing	2J1-1

TABLE

2A1-I	Equipment and materials	2A1-1
2A1-II	Nylon stuffing tube sizes for optical fiber cable	2A1-2
2A1-III	Nylon stuffing tube data	2A1-2
2B1-I	Equipment and materials	2B1-1
2B1-II	MCP data and insert block sizes for optical fiber cables	2B1-2
2C1-I	Equipment and materials	2C1-1
2D1-I	Equipment and materials	2D1-1
2E1-I	Equipment and materials	2E1-1
2F1-I	Equipment and materials	2F1-1
2F1-II	Fiber color coding	2F1-8
2G1-I	Equipment and materials	2G1-1
2G1-II	Nylon stuffing tube sizes for BOF cable	2G1-2
2G1-III	Nylon stuffing tube data	2G1-2
2H1-I	Equipment and materials	2H1-1
2H1-II	MCP data and insert block sizes for BOF cables	2H1-2
2I1-I	Equipment and materials	2I1-1
2I2-I	Equipment and materials	2I2-1
2J1-I	Equipment and materials	2J1-1

FIGURE

2-1	Example patch panel configuration	11
2A1-1	Straight tube	2A1-3
2A1-2	"Y" (45°) tube	2A1-4
2A1-3	90° angle tube	2A1-4
2A1-4	NPT tube	2A1-5
2B1-1	Interconnection box integral MCP-(typical)	2B1-3
2C1-1	Forming and shaping - (typical)	2C1-3
2C1-2	Compressing ferrule springs	2C1-5
2C1-3	Splices installed in splice tray - (typical)	2C1-5
2D1-1	Opening alignment sleeve	2D1-2
2D1-2	Inserting ferrule into alignment sleeve	2D1-3
2D1-3	Inserting second ferrule into alignment sleeve	2D1-3
2D1-4	Aligning tabs	2D1-4
2D1-5	Active splice alignment cable hookup	2D1-4
2E1-1	Aligning the loose tube furcation cables	2E1-3
2E1-2	Folding back the kevlar	2E1-3
2E1-3	Furcation cables joined to the BOF tube	2E1-4
2E1-4	Completed assembly	2E1-5
2F1-1	Short BOF tube and fibers	2F1-4
2F1-2	Short BOF tube and fibers	2F1-6
2F1-3	BOF tube and fibers	2F1-7
2F1-4	Feeding fibers into the furcation unit	2F1-7
2F1-5	Installed furcation unit	2F1-8
2G1-1	Straight tube	2G1-3
2G1-2	"Y" (45°) tube	2G1-3
2G1-3	90° angle tube	2G1-4

MIL-STD-2042-2B(SH)

2G1-4	NPT tube	2G1-4
-------	----------------	-------

CONTENTS

<u>FIGURE</u>		<u>PAGE</u>
2H1-1	Interconnection box integral MCP typical	2H1-2
2I1-1	Routing BOF tubes in TRB	2I1-2
2I1-2	Typical jumper tube paths	2I1-4
2I2-1	Routing BOF tubes in a FOICB	2I1-3

MIL-STD-2042-2B(SH)

1. SCOPE

1.1 Scope. This standard provides detailed methods for the installation of fiber optic cable topology equipment (see 3.16), and optical fiber cable entry to fiber optic cable topology and other equipment.

1.1.1 Applicability. These criteria apply to installations on specific ships when invoked by the governing ship specification or other contractual document. They are intended primarily for new construction; however, they are also applicable for conversion or alteration of existing ships. The rapidly changing state of the art in fiber optic technology makes it essential that some degree of flexibility be exercised in enforcing this document. When there is a conflict between this document and the ship specification or contract, the ship specification or contract take precedence. Where ship design is such that the methods herein cannot be implemented, users should submit new methods or modifications of existing methods for approval prior to implementation to: Department of the Navy, Naval Surface Warfare Center, Dahlgren Division, ATTN: Code B35, 17320 Dahlgren Road, Dahlgren, VA 22448-5100.

MIL-STD-2042-2B(SH)

2. APPLICABLE DOCUMENTS

2.1 General. The documents listed in this section are specified in sections 3, 4 and 5 of this standard practice. This section does not include documents cited in other sections of this standard practice or recommended for additional information or as examples. While every effort has been made to ensure the completeness of this list, document users are cautioned that they must meet all specified requirements documents cited in sections 3, 4 and 5 of this standard practice, whether or not they are listed.

2.2 Government documents.

2.2.1 Specifications, standards and handbooks. The following specifications, standards, and handbooks form a part of this document to the extent specified herein. Unless otherwise specified, the issues of these documents are those listed in the issue of the Department of Defense Index of Specifications and Standards (DODISS) and supplement thereto, cited in the solicitation (see 6.2).

FEDERAL SPECIFICATIONS

- | | |
|-----------|---|
| A-A-00272 | - Caulking Compounds. |
| A-A-59728 | - Plug, Tube Fitting, Blown Optical Fiber. |
| A-A-59729 | - Furcation Units, Tube, Blown Optical Fiber. |
| A-A-59730 | - Plugs, Tapered Tube, Blown Optical Fiber. |
| A-A-59731 | - Fittings, Tube, Blown Optical Fiber. |

DEPARTMENT OF DEFENSE SPECIFICATIONS

- | | |
|-----------------|--|
| MIL-DTL-15024 | - Plates, Tags and Bands for Identification of Equipment. |
| MIL-DTL-15024/5 | - Plate, Identification. |
| MIL-E-24142 | - Enclosures for Electrical Fittings and Fixtures, General Specification For. |
| MIL-S-24235 | - Stuffing Tubes, Metal and Packing Assemblies for Electric Cables, General Specification for. |
| MIL-PRF-24623 | - Splice, Fiber Optic Cable, General Specification for (Metric). |
| MIL-PRF-24623/4 | - Splice, Fiber Optic, Housing, Fiber. |
| MIL-I-24728 | - Interconnection Box, Fiber Optic, Metric, General Specification for. |

DEPARTMENT OF DEFENSE STANDARDS

- | | |
|--------------|---|
| MIL-STD-461 | - Electromagnetic Emission and Susceptibility Requirements for the Control of Electromagnetic Interference. |
| MIL-STD-889 | - Dissimilar Metals. |
| MIL-STD-1310 | - Shipboard Bonding, Grounding, and other Techniques for Electromagnetic Compatibility and Safety. |
| MIL-STD-2003 | - Electric Plant Installation Standard Methods for Surface Ships and Submarines. |

MIL-STD-2042-2B(SH)

- MIL-STD-2003-1 - Electric Plant Installation Standard Methods for Surface Ships and Submarines (Cable).
- MIL-STD-2003-2 - Electric Plant Installation Standard Methods for Surface Ships and Submarines (Equipment).
- MIL-STD-2042-1 - Fiber Optic Topology Installation Standard Methods for Naval Ships (Cables)(Part 1 of 7 Parts).
- MIL-STD-2042-5 - Fiber Optic Topology Installation Standard Methods for Naval Ships (Connections and Interconnections)(Part 5 of 7 Parts).
- MIL-STD-2042-6 - Fiber Optic Topology Installation Standard Methods for Naval Ships (Tests)(Part 6 of 7 Parts).

(Unless otherwise indicated, copies of the above specifications, standards, and handbooks are available from the Standardization Documents Order Desk, 700 Robbins Ave, Building 4D, Philadelphia, PA, 19111-5094.)

2.2.2 Other Government documents. The following other Government documents form a part of this document to the extent specified herein. Unless otherwise specified, the issues are those cited in the solicitation.

DEPARTMENT OF DEFENSE DRAWINGS

- NAVSEA Drawing - 6872812 Tool Kit, MIL-S-24623, Fiber Optic, Navy Shipboard.

NAVSEA TECHNICAL PUBLICATIONS

- S9074-AR-GIB-010/278 - Welding and Casting.

(Copies of documents should be obtained from the contracting activity or as directed by the contracting officer.)

2.3 Non-Government publications. The following documents form a part of this document to the extent specified herein. Unless otherwise specified, the issues of the documents which are DOD adopted are those listed in the issue of the DODISS cited in the solicitation. Unless otherwise specified, the issues of documents not listed in the DODISS are the issues of the documents cited in the solicitation (see 6.2).

AMERICAN NATIONAL STANDARDS INSTITUTE (ANSI)

- ANSI Z136.2 - Safe Use of Optical Fiber Communication Systems Utilizing Laser Diode and LED Sources

(Application for copies should be addressed to the American National Standards Institute, 1430 Broadway, New York, NY 10018-3308.)

AMERICAN SOCIETY FOR TESTING AND MATERIALS (ASTM)

- ASTM F1836M - Standard Specification for Stuffing Tubes, Nylon, and Packing Assemblies (Metric)

(Application for copies should be addressed to the American Society for Testing and Materials, 100 Barr Harbor Drive, West Conshohocken, PA 19428-2959.)

MIL-STD-2042-2B(SH)

ELECTRONICS INDUSTRY ASSOCIATION/TELECOMMUNICATIONS INDUSTRY ASSOCIATION

EIA/TIA-440 - Fiber Optic Terminology.

(Application for copies should be addressed to Global Engineering Documents, 1990 M Street NW, Suite 400, Washington, DC 20036.)

SOCIETY OF AUTOMOTIVE ENGINEERS (SAE)

SAE AMS-DTL-23053/5 - Insulation Sleeving, Electrical, Heat Shrinkable, Polyolefin, Flexible, Crosslinked.

SAE AS 23190 - Straps, Clamps and Mounting Hardware, Plastic and Metal for Cable Harness Tying and Support.

(Application for copies should be addressed to Society of Automotive Engineers, 400 Commonwealth Drive, Warrendale, PA 15096-0001)

2.4 Order of precedence. In the event of a conflict between the text of this document and the references cited herein, the text of this document takes precedence. Nothing in this document, however, supersedes applicable laws and regulations unless a specific exemption has been obtained.

MIL-STD-2042-2B(SH)

3. DEFINITIONS

3.1 General fiber optics terms. Definitions for general fiber optics terms used in this standard practice are in accordance with EIA/TIA-440. Definitions for other terms as they are used in this standard practice are given in the following paragraphs.

3.2 Acronyms. The following acronyms are used in this standard practice:

BOF Blown optical fiber
FOCP Fiber optic cable plant
FOCT Fiber optic cable topology
FOICB Fiber optic interconnection box
TRB Tube routing box

3.3 Allocated and not used fiber. A fiber that is designated for use for a particular system, but is not being used to transmit information. Allocated and not used fibers include fibers allocated as system spare fibers, system growth fibers, and system redundant fibers.

3.4 Allocated and used fiber. A fiber that is designated and required for use for a particular system link, and is being used to transmit information. Allocated and used fibers include fibers used for normal channels, fiber for alternate channels, and fibers for non-redundant channels.

3.5 Alternate channel. The allocated and used active backup link for a normal channel.

3.6 Authorized approval. Written approval from the cognizant Government activity.

3.7 BOF bundle. A group of optical fibers within a special jacket that allows the entire bundle to be blown into a BOF tube.

3.8 BOF cable. A cable that contains one or more BOF tubes through which optical fibers or optical fiber bundles are blown.

3.9 BOF fiber. An optical fiber with a special coating that allows the fiber to be blown into a BOF tube.

3.10 BOF path. The unique assemblage of concatenated BOF tubes, which form a continuous conduit through the FOCP between two BOF end points.

3.11 BOF tube. A tube within a BOF cable through which BOF fibers or BOF bundles are blown.

3.12 BOF tube coupler. A device used to join two BOF tubes together.

3.13 BOF tube routing box (TRB). An enclosure for holding BOF cables (trunk and local), BOF tubes (trunk and local), and tube couplers to interconnect BOF tubes.

3.14 End user equipment. Any cabinet, case, panel, or device that contains components that are either the origin or destination of an optical signal.

3.15 Fiber optic cable plant (FOCP). A subset of the FOCT that excludes local cables and their associated components. A conventional FOCP includes FOICBs, trunk cables and their associated connectors and splices. A BOF FOCP consists of FOICBs, TRBs, tube couplers, BOF trunk cables, BOF fibers, BOF bundles, tube furcation units and associated connectors and splices.

MIL-STD-2042-2B(SH)

3.16 Fiber optic cable topology. An integrated optical fiber distribution system that provides the optical interconnection between end user equipments. A conventional FOCT includes the conventional FOCP components and outlet boxes, local cables and their associated connectors and splices. A BOF FOCT includes the BOF FOCP components, BOF cable furcations, local conventional cables, local BOF cables, and associated connectors and splices.

3.17 Fiber optic interconnection box (FOICB). An enclosure for holding optical fiber cable (BOF and conventional), BOF tubes, tube furcation units, and optical fiber splices, connectors and adapters.

3.18 Installing activity. Any military, commercial, or industrial organization involved with the installation of fiber optic cable topologies aboard Naval ships.

3.19 Local cable.

3.19.1 Local conventional cable. A conventional optical fiber cable that runs between an end user equipment and an FOICB (or outlet box), or between an FOICB and an outlet box.

3.19.2 Local BOF cable. A BOF cable that runs between end user equipment and a TRB, or between a TRB and an outlet box.

3.20 Minimum bend diameter. The diameter at which a conventional optical fiber cable, OFCC (see 3.25), loose tube furcation cable, or BOF bundle (see 3.7) can be bent without degrading optical performance, or the diameter at which a BOF cable or BOF tube (see 3.11) can be bent without kinking a BOF tube. The short-term bend diameter applies during handling and installing; the long-term bend diameter applies to the completed installation.

3.21 Multiple cable penetrator (MCP). A device that provides a means for making watertight, airtight, and firetight penetrations through decks, bulkheads, and into equipment.

3.22 Non-redundant channel (NRC). Any allocated and used active link that has no system required backup link.

3.23 Normal channel. An allocated and used active link between system equipment that has a designated active backup link.

3.24 Optical fiber cable. A cable that contains optical fibers.

3.24.1 BOF cable. A cable that contains one or more BOF tubes through which BOF fibers or BOF bundles are blown.

3.24.2 Conventional optical fiber cable. An optical fiber cable in which the optical fiber is an integral part of the cable and is installed during the cable manufacturing process.

3.25 Optical fiber cable component (OFCC). A buffered fiber augmented with a concentric layer of strength members and an overall jacket.

3.26 Outlet box. A small termination box used to break out a local cable from an FOICB or TRB to one or more end user equipments in a compartment or area.

3.27 Spare fiber. A fiber reserved for use as a maintenance spare in the event of damage to an allocated fiber within the FOCT.

MIL-STD-2042-2B(SH)

3.27.1 FOCP spare fiber. An unallocated spare fiber for use by any system using the FOCP.

3.27.2 System spare fiber. A spare fiber that is allocated and not used and that is reserved for use by a specific system.

3.28 Trunk. A set of trunk cables that run along the same cableways between two FOCP boxes (TRBs, FOICBs).

3.29 Trunk cable. An optical fiber cable that runs between two FOICBs. Typically, trunk cables are run in the main cableways and have higher fiber counts per cable than local cables.

3.29.1 Conventional trunk cable. A conventional optical fiber cable that runs between two FOICBs.

3.29.2 BOF trunk cable. A single BOF cable connected between two FOCP TRBs or between a FOCP TRB and a FOCP FOICB. A BOF trunk cable contains multiple BOF trunk tubes.

3.30 Tube furcation unit. An assembly attached to the end of a BOF tube in a BOF cable used to separate the fibers and provide a cable structure to facilitate the termination of the optical fibers from that BOF tube.

3.31 Unused fiber. A fiber that is not designated for use for any system and not required as part of the FOCT configuration. Unused fibers occur within the fiber optic cable topology when the required systems fibers are less than the number of fibers available within a standard cable size.

MIL-STD-2042-2B(SH)

4. GENERAL REQUIREMENTS

4.1 Fiber optic equipment installation. Interconnection boxes in accordance with MIL-I-24728 and tube routing boxes in accordance with MIL-I-24728 or MIL-E-24142 shall be installed as specified herein. These methods may be extended to other fiber optic equipment when specified by the ship specification or the system drawings.

4.1.1 Interconnection box and tube routing box selection. The interconnection boxes and tube routing boxes selected shall be those identified in the ship specifications and drawings. Substitute boxes shall not be used without authorized approval (see 3.6). In those instances where the installing activity (see 3.18) is responsible for interconnection box selection, the box type shall be selected from MIL-I-24728 or as approved by the Naval Surface Warfare Center (see 1.1.1). The box shall be sized to provide sufficient capacity to accept the total number of fibers entering the box (including growth fibers) as specified by the ship specification and system drawings. For boxes with BOF cabling, interconnection boxes shall have capacity for fiber that may be installed in unused BOF trunk tubes. In those instances where the installing activity is responsible for tube routing box selection, the box type shall be selected from either MIL-E-24142, MIL-I-24728, or as approved by the Naval Surface Warfare Center (see 1.1.1). Tube routing boxes shall be sized to provide sufficient capacity to accept the total number of BOF tubes entering the box.

4.1.2 Location. Boxes shall be located in accordance with the system drawings. In those instances where the installing activity is responsible for selecting box location, the following requirements apply:

- a. In instances where a box interfaces directly with only one end user equipment, the box shall be located as close as possible to that equipment without interfering with any other systems or violating any other requirements specified herein. If a box interfaces directly with two or more end user equipments, the box shall be so located as to keep the majority of local cable (see 3.19) runs as short as possible. For end user equipment with local cables that are required to be survivably separated, the boxes that connect these local cables to trunk cables shall be located in different compartments, except for the case where the interconnection box and the equipment are in the same compartment. In this situation, both cables may be run from the equipment to the same box.
- b. Boxes shall be located in spaces protected from the weather whenever possible. Boxes shall not be installed in voids or inaccessible spaces. If mounting the box within gun or missile blast areas cannot be avoided, it shall be located clear of maximum deflection or whip of bulkheads and deck plating.
- c. Unless otherwise approved by NAVSEA, box location shall provide ready access and entry for maintenance. No part of the box should be at a height greater than 7 feet above the deck, with the preferred maximum height being 5 feet. There shall be a minimum of 2 feet of clearance in front of the box.

4.1.3 Interconnection box mounting. Interconnection boxes shall be mounted in accordance with methods specified in 5.1.

4.1.3.1 Bonding, grounding, and shielding. Boxes that contain active fiber optic components, such as switches or transceivers, shall be bonded, grounded, and shielded in accordance with MIL-STD-1310. Bonding, grounding, and shielding inside the box shall be in accordance with MIL-STD-1310 and MIL-STD-461.

MIL-STD-2042-2B(SH)

4.1.3.2 Holes drilled in beams. Holes drilled in structural members for passing cables or securing equipment shall be on the neutral axis of the beam or between the neutral axis and the point of attachment. Reinforcement of holes, where required, shall be in accordance with the applicable ship specification.

4.1.3.3 Welding. Unless otherwise noted, welding of studs, step hangers, tapped pads, mounting pads, and extension hangers shall be in accordance with NAVSEA Technical Publication S9074-AR-GIB-010/278. Any required tapping shall be done before welding.

4.1.3.4 Fasteners. Material for the bolts, nuts, machine screws and washers used to fasten boxes to decks and bulkheads shall be as specified in the ship specification and drawings, and in the methods described herein. Locking devices in accordance with ship specifications shall be used for bolts that secure the boxes. Through-bolts and self-locking nuts shall be used to mount boxes located:

- a. In gun mounts.
- b. In missile launch areas.
- c. In submarine battery compartments above the level of the lowest cell tops.

4.1.3.5 Dissimilar metals. Where design requirements preclude the isolation of incompatible metal combinations, as identified in MIL-STD-889, from one another, the area in contact shall, as a minimum, be coated, treated, or otherwise insulated against corrosion in accordance with Appendix A of MIL-STD-889.

4.2 Cable entrance to equipment. Optical fiber cables shall enter equipment in accordance with the methods described herein and as follows:

- a. Cables shall enter splashproof, spraytight, watertight, submersible, and explosionproof equipment through multiple cable penetrators (MCP's) integral to the equipment or through stuffing tubes. When stuffing tubes are used, entrance shall be made through the bottom or sides of the equipment where possible. Stuffing tubes used to enter splashproof, spraytight, or watertight equipment shall be nylon in accordance with ASTM F1836M. Stuffing tubes used to enter submersible (50 foot) and explosionproof equipment shall be metal in accordance with MIL-S-24235.
- b. Cables shall enter molded plastic equipment through nylon stuffing tubes.
- c. The entrance of cables via connector plugs and receptacles shall be as specified on the applicable ship or system drawings.
- d. The entrance and grounding of electrical cables using MCP's integral to the equipment shall be as specified on the applicable ship or system drawings.

4.2.1 Cable slack. Cables shall be secured to ship structure as close as possible to the equipment without violating cable long term bend diameter (see 3.20) requirements. Cables entering hard-mounted equipment shall have sufficient slack between the equipment and the last point of cable support, to prevent damage to the cable caused by vibration. Cables connected to equipment provided with resilient or shock mounts shall have a minimum length of 46 cm (18 in) with not less than 8 cm (3 in) of slack between the equipment and the last point of support of the cable to provide for flexibility and movement of the equipment under shock, vibration, and in-service loading. Cables terminated in a heavy duty (multiple terminus) connector shall have an additional minimum of 25 cm (10 in) of slack in the cableway from which the cable exits to provide for two reterminations. For cables that enter equipment by way of stuffing tubes or MCP's, there shall be enough slack inside the

MIL-STD-2042-2B(SH)

equipment for a minimum of two reterminations. Where connectors are used for cable entrance to equipment, the cables shall be installed such that the connectors may be easily removed.

4.2.2 Cable forming and shaping. Optical Fiber Cable Components (OFCCs), loose tube furcation cables, and buffered fibers within interconnection boxes shall be routed around the inside edges of the box such that they do not block or otherwise obstruct access to any connections within the box. The group or bundle of OFCCs or loose tube furcation cables shall be protected from possible damage on sharp edges by using ties, clamps or tubing. Care shall be taken when attaching the group or bundle as shown in the methods herein to prevent kinking or cutting the OFCC or loose tube furcation cable jackets and to ensure that bends do not violate the minimum short term bend diameter of eight times the OFCC or loose tube furcation cable OD and the minimum long term bend diameter of sixteen times the OFCC or loose tube furcation cable OD.

4.2.3 Tube forming and shaping. BOF tubes within interconnection boxes shall be routed around the inside edges of the box such that they do not block or otherwise obstruct access to any connections within the box. BOF tubes within tube routing boxes shall be routed around the inside edges of the box to the maximum extent practicable. The tubes shall be organized using ties, clamps or other organization devices. Care shall be taken when organizing the BOF tubes as shown in the methods herein to prevent kinking or crushing the tubes and to ensure that bends do not violate the tube minimum short term and long term bend diameter of 130 mm (5 in).

4.2.4 Splice assembly and alignment. The mating and alignment of splice ferrules shall be accomplished after they enter the equipment as specified herein. The fiber optic splice ferrules shall be installed on the buffered fibers in accordance with Method 5C1 in Part 5 of this standard practice.

4.2.5 Interconnection organization. Fiber optic connectors and adapters shall be mounted on the optical patch panels mounted in the interconnection box. The position of each connector shall be in accordance with system drawings. Unterminated fibers shall be tied off in the bundle. The reservation of unused connection spaces for unterminated fibers shall be as specified in the ship specification. If the installing activity is responsible for the internal configuration of the interconnection box, the configuration shall be in accordance with 4.2.5.1.

4.2.5.1 Connector organization. The individual patch panels shall be filled starting with the row closest to the inside of the box and working outward (see figure 2-1 for guidance). Allocated fibers [normal, alternate, and NRC fibers (see 3.23, 3.5, and 3.22) and system growth and spare fibers] shall be located nearest the inside of the box. Spare fibers (see 3.27) shall be located in close proximity to their respective allocated fibers. Unused adapters shall be located closest to the outside of the box.

MIL-STD-2042-2B(SH)

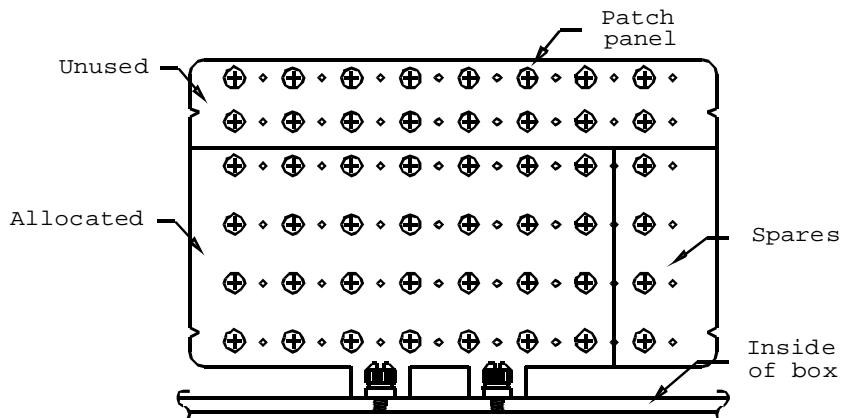
FIGURE 2-1. Example patch panel configuration.

4.2.6 Nameplates and marking. Nameplates shall be provided for all equipment and shall be in accordance with MIL-DTL-15024 and MIL-DTL-15024/5. Marking shall be as specified in the ship specification, applicable drawings, and the requirements herein. Interconnection box and tube routing box identification and location plates shall be located on the outside of the cover. Cable marking at an equipment shall be in accordance with Part 1 of this standard practice.

4.2.6.1 Internal interconnection box marking. Each connector or adapter position on the optical patch panels shall be marked. A configuration chart showing all the connections within the box shall be permanently attached to the inside of the box. The input and output cable and fiber numbers and the connector position number shall be shown for each connection. The configuration chart for BOF interconnection boxes shall also provide the furcation unit identification number and the tube identification number for each connection. For unterminated fibers, the configuration chart shall show the patch panel adapter number reserved for each fiber (if applicable). In those instances where lasers are used as optical sources, each interconnection box shall be internally marked in accordance with ANSI Z136.1. In those instances where BOF connections or furcation units are contained within the interconnection box, the box shall be internally marked in a conspicuous location with the following:

"CAUTION: DO NOT DISENGAGE MATED BOF TUBE COUPLERS UNLESS AUTHORIZED. DISENGAGING UTILIZED BOF TUBE COUPLERS MAY DAMAGE/BREAK THE OPTICAL FIBERS CONTAINED WITHIN THE BOF TUBES."

4.2.6.2 Internal tube routing box marking. A configuration chart showing all the tube connections within the box shall be permanently attached to the inside of the box. The path identification and the tube identification numbers of the connected tubes shall be shown for each pair of connected tubes. BOF tube routing boxes shall be internally marked in a conspicuous location with the following:

"CAUTION: DO NOT DISENGAGE MATED BOF TUBE COUPLERS UNLESS AUTHORIZED. DISENGAGING UTILIZED BOF TUBE COUPLERS MAY DAMAGE/BREAK THE OPTICAL FIBERS CONTAINED WITHIN THE BOF TUBES."

4.2.7 BOF tube end termination. BOF tubes within equipment shall always be terminated to other BOF tubes, BOF tube furcation units or end caps. BOF

MIL-STD-2042-2B(SH)

termination devices shall be as specified herein or as approved by the Naval Surface Warfare Center (see 1.1.1).

- 4.3 Safety precautions. The following safety precautions apply:
- a. Observe all written safety precautions given in the methods of this standard practice.
 - b. Observe all warning signs on equipment and materials.
 - c. The classification of a laser is based on the ability of the optical beam to cause damage to the eye. Under normal operating conditions, an optical fiber communication system (OFCS) is inherently an eye safe system; but, when an optical fiber connection is broken and optical viewing instruments are used, it is possible that hazardous energy can enter the eye. For this reason four service group hazard classes have been devised to indicate the degree of hazard and required hazard control measures. Refer to ANSI Z136.2 for a full technical definition. The following laser safety precautions shall apply:
 - (1) Ensure personnel are familiar with the laser degree of hazard and the required control measures.
 - (2) Light generated by light emitting diodes (LED's) and laser diodes may not be visible but may still be hazardous to the unprotected eye. Never stare into the end of an optical fiber connected to an LED or laser diode and do not stare into broken, severed or disconnected optical cables.
 - (3) Do not view the primary beam or a specular reflection from an OFCS with an optical microscope, eye loupe or other viewing instrument. The instrument may create a hazard due to its light gathering capability.
 - d. Safety glasses shall be worn when handling bare fibers. Always handle cable carefully to avoid personal injury. The ends of optical fibers may be extremely sharp and can lacerate or penetrate the skin or cause permanent eye damage if touched. If the fiber penetrates the skin, it most likely will break off, in which case the extraction of the fiber should be performed by trained medical personnel to prevent further complications.
 - e. Never look into the end of a BOF tube. Always wear approved safety glasses when handling BOF tubes that may be connected to a pressure source.
 - f. Wash hands after handling bare fibers.
 - g. Do not eat or drink in the vicinity of bare optical fibers. Ingested optical fibers may cause serious internal damage.

MIL-STD-2042-2B(SH)

5. DETAILED REQUIREMENTS

5.1 Fiber optic interconnection equipment installation. The methods covered here are applicable to the fiber optic interconnection boxes and tube routing boxes. They may be extended to other fiber optic interconnection equipment only after contacting the contracting activity. The mounting of these boxes on ship structure is the same as the standard mounting methods of electrical enclosures given in MIL-STD-2003-2. These methods will not be repeated in this standard practice; however, they are identified and listed here to aid the user in rapidly locating the applicable method in MIL-STD-2003-2 to be used for installing the fiber optic interconnection box or the tube routing box. For interconnection equipment containing single mode fiber connections, shock isolation mounting methods may be required to meet system requirements. When shock isolation mounting of interconnection equipment is required, interconnection equipment mounting shall be as specified in the installation drawings.

5.1.1 Non-watertight decks and bulkheads. The following methods shall be used to install interconnection boxes or tube routing boxes on non-watertight decks and bulkheads:

- a. Steel decks and bulkheads: MIL-STD-2003-2, Figure 2A1 or 2A4.
- b. Aluminum decks and bulkheads: MIL-STD-2003-2, Figure 2A6 or 2A8.

5.1.2 Watertight decks and bulkheads. The following methods shall be used to install interconnection boxes or tube routing boxes on watertight decks and bulkheads:

- a. Steel decks and bulkheads: MIL-STD-2003-2, Figure 2A1 or 2A2.
- b. Aluminum decks and bulkheads: MIL-STD-2003-2, Figure 2A6 or 2A7.

5.1.3 Stanchions. The following methods shall be used to install interconnection boxes or tube routing boxes on stanchions:

- a. Steel stanchion: MIL-STD-2003-2, Figure 2A5.
- b. Aluminum stanchion: MIL-STD-2003-2, Figure 2A9.

5.1.4 Metal joiner bulkheads. The following method shall be used to install interconnection boxes or tube routing boxes on metal joiner bulkheads:

MIL-STD-2003-2, Figure 2A11.

5.1.5 Expanded metal or wire mesh bulkhead. The following methods shall be used to install interconnection boxes or tube routing boxes on expanded metal or wire mesh bulkheads:

MIL-STD-2003-2, Figure 2A12 or 2A13.

5.1.6 Refrigerated spaces. The following method shall be used to install interconnection boxes or tube routing boxes in refrigerated spaces:

MIL-STD-2003-2, Figure 2A16.

5.1.7 GRP (glass reinforced plastic) bulkheads. The following methods shall be used to install interconnection boxes or tube routing boxes on GRP bulkheads:

MIL-STD-2003-2, Figure 2A23 or 2A24 and Figure 2A25.

MIL-STD-2042-2B(SH)

5.1.8 Locking devices for installations on submarines. Locking devices of the following method shall be used in the installation of interconnection boxes or tube routing boxes on submarines:

MIL-STD-2003-2, Figure 2A21.

5.2 Cable entrance to equipment. Optical fiber cable entrance into equipment may employ the same devices (that is, stuffing tubes) used for electric cable entrance into equipment. When these devices are used and the procedures are the same for both cable types, the methods will not be repeated in this standard practice. However, the methods are identified and listed here to aid the user in rapidly locating the applicable method in MIL-STD-2003. Methods unique to optical fiber cable or that differ from those for electric cable shall be in accordance with this standard practice.

5.2.1 Nylon stuffing tubes. Conventional cable and BOF cable entry into spraytight, splashproof, molded plastic and watertight equipment via nylon stuffing tubes shall be in accordance with Method 2A1 and Method 2G1 of this standard practice, respectively.

5.2.2 Multiple cable penetrator (MCP). Conventional cable and BOF cable entry into equipment via integral MCP's shall be in accordance with Method 2B1 and Method 2H1 of this standard practice, respectively.

5.2.3 Cable clamps. Cable entry into equipment via cable clamps shall not be permitted.

5.3 Interconnection organization.

5.3.1 Conventional cable. The organization of the connectors and adapters and the shaping of the OFCCs and buffered fibers within the interconnection box shall be in accordance with Method 2C1 of this standard practice.

5.3.2 BOF cable. The forming, routing, and shaping of BOF tubes within tube routing boxes and interconnection boxes shall be in accordance with Method 2I1 and Method 2I2 of this standard practice. The organization of the connectors and adapters and the shaping of the loose tube furcation cables within the interconnection box shall be in accordance with Method 2C1 of this standard practice.

5.4 Splice assembly and alignment. The interconnection of splice ferrules within the equipment shall be in accordance with Method 2D1 of this standard practice.

5.5 BOF tube furcation unit fabrication. Fabricated BOF tube furcation units shall be constructed in accordance with Method 2E1 of this standard practice. Other tube furcation units shall be in accordance with A-A-59729.

5.6 BOF tube furcation unit installation. BOF tube furcation units shall be used to provide a transition for BOF fibers from BOF cable to fiber optic connectors. Furcation units shall be installed in accordance with Method 2F1 of this standard practice.

5.7 BOF tube end sealing. The sealing of unused BOF tube ends shall be in accordance with Method 2J1 of this standard practice.

MIL-STD-2042-2B(SH)

6. NOTES

(This section contains information of a general or explanatory nature that may be helpful, but is not mandatory.)

6.1 Intended use. The methods for equipment mounting and cable entrance to equipment depicted in this standard practice are intended primarily for new construction; however, they are applicable for conversion or alteration of existing ships.

6.2 Issue of DODISS. When this standard practice is used in acquisition, the applicable issue of the DODISS must be cited in the solicitation (see 2.2.1 and 2.3).

6.3 Standard method designation. To simplify the usage of this standard practice, an alphanumeric designation system was developed to identify and locate a given method. The methods were grouped together by function as follows:

- Group A: Conventional cable entrance to equipment via nylon stuffing tubes.
- B: Conventional cable entrance to equipment via MCP.
- C: Conventional cable and buffered fiber forming and shaping.
- D: Splice assembly and alignment.
- E: BOF tube furcation unit fabrication.
- F: BOF tube furcation unit installation.
- G: BOF cable entrance to equipment via nylon stuffing tubes.
- H: BOF cable entrance to equipment via MCP.
- I: BOF cable forming, routing, and shaping.
- J: BOF tube end sealing.

Then the designation system was completed as follows:

2 B 1 -

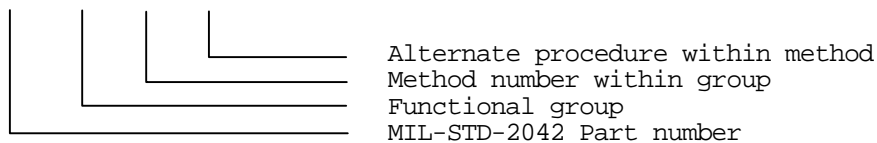

Thus, method 2B1 indicates there is no alternate procedure for method 1 of group B in Part 2 (MIL-STD-2042-2) of MIL-STD-2042.

6.4 Subject term (key word) listing.

- Component
- Entrance into equipment
- Interconnection box
- Interconnection box selection
- Interconnection organization
- Nameplates and marking
- Splice assembly and alignment

6.5 Changes from previous issue. Marginal notations are not used in this revision to identify changes with respect to the previous issue, due to the extent of the changes.

Preparing activity:
NAVY - SH

(Project SESS-0006)

MIL-STD-2042-2B(SH)

METHOD 2A1

CONVENTIONAL CABLE ENTRANCE TO EQUIPMENT VIA NYLON STUFFING TUBES

1. SCOPE.

1.1 Scope. This method describes a procedure for optical fiber cable entry to fiber optic cable topology and other equipment through nylon stuffing tubes.

2. REQUIRED EQUIPMENT AND MATERIALS.

2.1 The equipment and materials in table 2A1-I shall be used to perform this procedure:

TABLE 2A1-I. Equipment and materials.

Description	Quantity
Safety glasses	1
Ruler	1
Deburring tool (or equivalent)	1
Paint scraper	1
Emery cloth	As required
Cable jacket stripping tool (NAVSEA DWG 6872812-08 or equal)	1
Kevlar shears (NAVSEA DWG 6872812-16 or equal)	1
Open end wrench (sized to fit locknut)	1
Spanner wrench (sized to fit cap)	1
RTV silicone rubber (Silastic 731731 or equal)	As required
Primer (type to suit metal)	As required
Talc (soap stone)	As required
Alcohol bottle with alcohol/2-propanol	1
Wipes	As required
Canned air (or compressed air)	As required

3. PROCEDURE.

3.1 Safety summary. The following safety precautions shall be observed:

- a. Safety glasses shall be worn at all times when handling bare fibers.
- b. Do not touch the ends of bare fiber as they may be razor sharp. Wash your hands thoroughly after handling bare fibers.

MIL-STD-2042-2B(SH)

- c. When visually inspecting an optical fiber, never stare into the end of a fiber connected to a laser source or LED.

3.2 Procedure.

NOTE: Packing assemblies and "O"-rings are not furnished with stuffing tubes. They must be ordered separately by the installing activity to suit installations.

Step 1 - Select the recommended stuffing tube, packing and "O"-ring in accordance with tables 2A1-II and 2A1-III.

TABLE 2A1-II. Nylon stuffing tube sizes for optical fiber cable.

Cable type	Cable OD mm (in) nominal	Tube size	Packing assembly part no. ASTM F1836M/	Packing assembly opening mm (in)
4-Fiber	8.1 (0.32)	2	17-001	8.26 (0.325)
8-Fiber	11.1 (0.44)	3	18-018	12.0 (0.472)
18-Fiber	14.3 (0.56)	4	19-003	14.8 (0.584)
36-Fiber	20.8 (0.82)	5	20-003	21.7 (0.853)

TABLE 2A1-III. Nylon stuffing tube data.

Stuffing tube sizes		Tube size 2	Tube size 3	Tube size 4	Tube size 5
Straight tube	Tube part number ASTM F1836M/	1-002	1-003	1-004	1-0006
	"O"-ring part number ASTM F1836M-	214	216	218	226
Angle tube	Tube part number ASTM F1836M/	2-002	2-003	2-005	2-006
	"O"-ring part number ASTM F1836M-	212	216	218	220
NPT Tube	Tube part number ASTM F1836M/	3-002	3-003	3-004	3-005
	NPT Tap mm (in)	19 (0.75)	25 (1.0)	25 (1.0)	38 (1.5)
"Y" Tube	Tube part number ASTM F1836M/	4-02	4-03	4-04	N/A
	"O"-ring part number ASTM F1836M-	214	216	220	N/A

MIL-STD-2042-2B(SH)

Step 2 - WARNING: Wear safety glasses during deburring to avoid possible eye injury.

Inspect the hole in the enclosure and remove any burrs or irregularities using the deburring tool.

Step 3 - For steel enclosures where the roughness is greater than a 125 microinch finish (not required on aluminum enclosures), remove the paint using a paint scraper and clean the surface with emery paper approximately 13 mm (0.5 inch) wide around the hole on the exterior of the enclosure. Apply one coat of primer, and allow to set. Dust coat the surface with talc if the primer is not thoroughly dried at the time of the tube installation. Remove the cover and proceed to step 4, 5 or 7 below, as applicable.

Step 4 - With straight tubes, insert the stuffing tube body into the hole from the inside of the enclosure (see figure 2A1-1). If necessary, remove the interior fitting from enclosure. Proceed to step 6 below.

Straight tube
ASTM F 1836M/1
(applies to angle tubes)

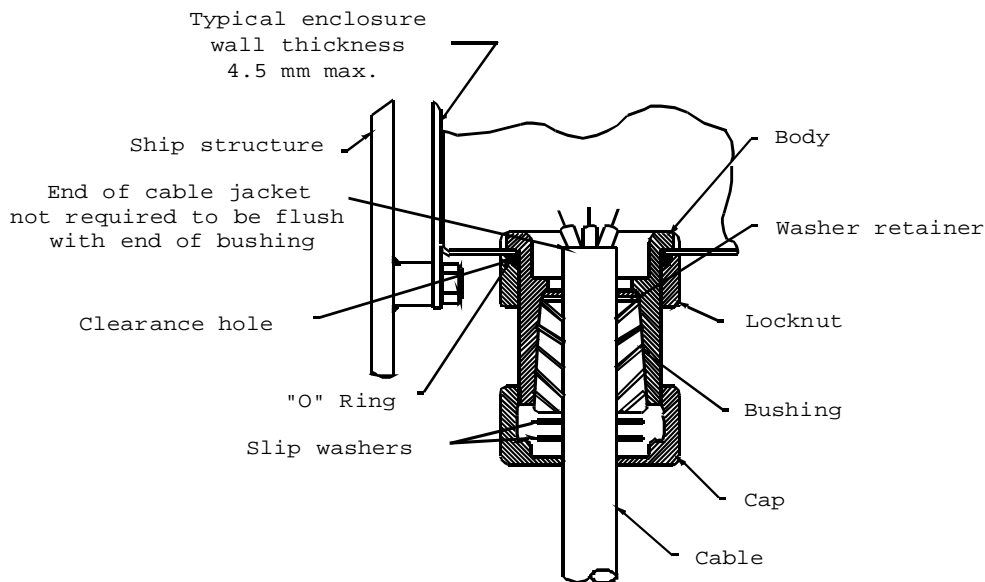

FIGURE 2A1-1. Straight tube.

MIL-STD-2042-2B(SH)

Step 5 - With "Y" and angle tubes, insert the stuffing tube body into the hole from the outside of enclosure (see figures 2A1-2 and 2A1-3). The excess length protruding into the enclosure may be removed.

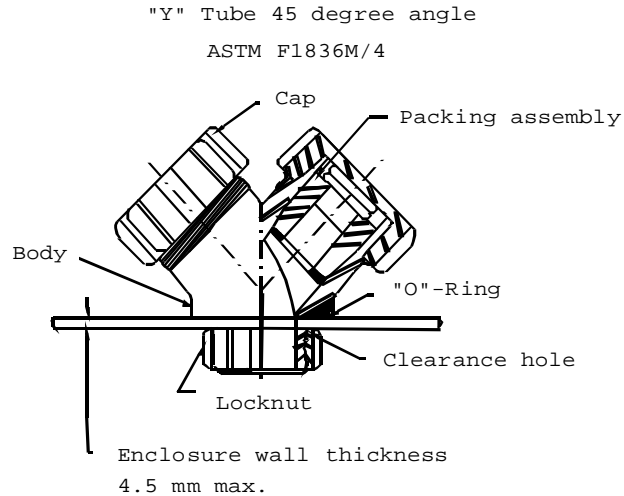

FIGURE 2A1-2. "Y" (45°) tube.

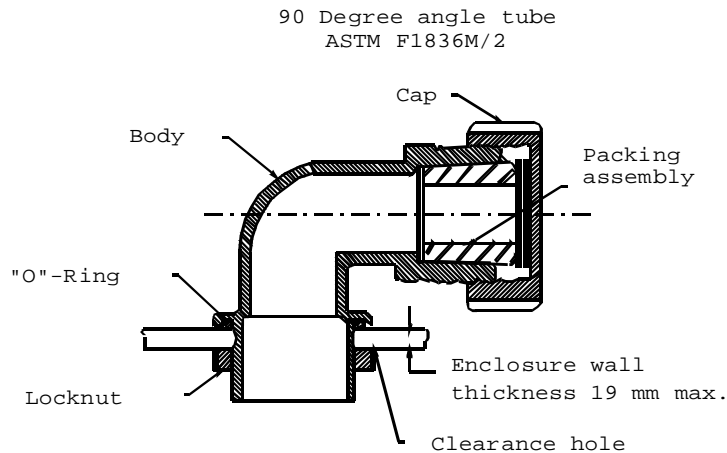
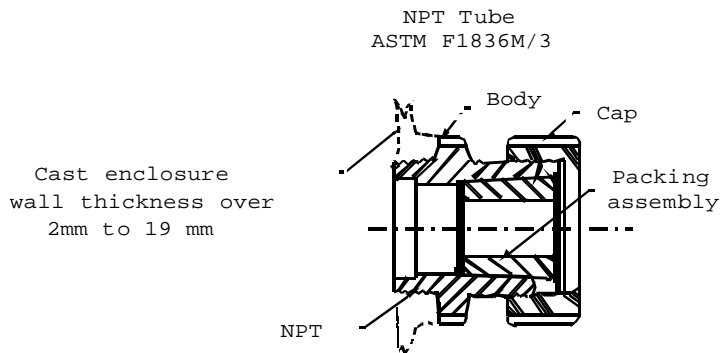

FIGURE 2A1-3. 90° angle tube.

Step 6 - Screw the locknut onto the body and tighten with a wrench against the "O"-ring sufficiently to obtain plastic to metal contact of the stuffing tube and the enclosure. In cases where this plastic to metal contact cannot be obtained, tighten the locknut until the threads start to skip. This is considered a satisfactory indication of tightness. (Note: Hold the stuffing tube body while tightening the locknut to prevent turning.) Proceed to step 8 below.

Step 7 - With NPT tubes, screw the tube into the enclosure pipe thread and tighten it sufficiently to obtain a seal at the threads (see figure 2A1-4).

MIL-STD-2042-2B(SH)

FIGURE 2A1-4. NPT tube.

Step 8 - Measure the length of the cable jacket to be removed:

For unterminated cables, measure the distance required to route OFCCs from innermost portion of the stuffing tube completely around the interior of the interconnection box (or to the furthestmost connection point in the end user equipment), add approximately 130 mm (5 in), and mark cable outer jacket.

For terminated cable assemblies, measure the distance required to route OFCCs from innermost portion of the stuffing tube to the furthestmost connection point in the equipment, add approximately 80 mm (3 in) and mark cable outer jacket. In an interconnection box the distance measured shall be great enough that the OFCC can be routed one-half of the way around the box and then to the termination point.

Step 9 - Slide the stuffing tube parts onto cable in the order indicated:

- a. Cap
- b. Two slip washers
- c. Rubber bushing
- d. Bottom washer

Step 10 - Slide the parts up the cable beyond the mark and, if not already done, remove the outer jacket up to the mark using the cable stripper.

CAUTION: Do not cut or nick OFCCs.

Cut off the cable kevlar strength members and exposed central member, if present, using kevlar shears.

NOTE: If cable strength member capture is planned, leave approximately 100 mm (4 in) of the kevlar strength members protruding from the cable jacket.

Step 11 - Remove the waterblocking material and clean the OFCCs using a wipe dampened with alcohol. Blow dry with air.

MIL-STD-2042-2B(SH)

- Step 12 -Insert the cable through the stuffing tube and into the enclosure so that the outer jacket will protrude completely through the rubber bushing. Slide the washers and bushing down the cable into the tube. (NOTE: When necessary to pass an airtight test, apply RTV silicone rubber to the bushing.)
- Step 13 -Slide the cap down the cable, screw it onto the tube and tighten it sufficiently using the spanner wrench to compress the bushing to form a tight seal between the cable and the tube. (NOTE: Hold the tube body when tightening the cap to prevent breaking the watertight seal.) After the bushing has been compressed for approximately 24 hours, retighten it to ensure the seal is maintained.
- Step 14 -If required, wind the exposed kevlar strength member under a screw lug attached beside the stuffing tube and tighten the screw lug.
- NOTE: This step is only performed when additional strain relief is required beyond that provided by the stuffing tube assembly.
- NOTE: Sealing plugs are for use in service to seal nylon stuffing tubes from which cables have been removed. When installing sealing plugs, the cable bushing shall be discarded but the nylon washers shall be retained and left in the stuffing tube.
- Step 15 -Install terminations on the OFCCs as specified on the system drawings using Part 5 of this standard practice.

MIL-STD-2042-2B(SH)

METHOD 2B1

CONVENTIONAL CABLE ENTRANCE TO EQUIPMENT VIA MCP

1. SCOPE.

1.1 Scope. This method describes a procedure for optical fiber cable entry to fiber optic cable topology and other equipment through multiple cable penetrators (MCP) integral to the equipment being entered. Procedures for electrical cable entry and grounding to equipment through MCPs integral to the equipment shall be as specified on the applicable ship or system drawings.

2. REQUIRED EQUIPMENT AND MATERIALS.

2.1 The equipment and materials in table 2B1-I shall be used to perform this procedure.

TABLE 2B1-I. Equipment and materials.

Description	Quantity
Safety glasses	1
Ruler	1
Tallow (Hevi-Duty/Nelson AA0099 or equal)	As required
Open end wrench (sized to fit wedgepack nut)	1
Cable jacket stripping tool (NAVSEA DWG 6872812-08 or equal)	1
Kevlar shears (NAVSEA DWG 6872812-16 or equal)	1

3. PROCEDURE.

3.1 Safety Summary. The following safety precautions shall be observed:

- a. Safety glasses shall be worn at all times when handling bare fibers.
- b. Do not touch the ends of bare fiber. Wash hands thoroughly after handling bare fibers.
- c. When visually inspecting an optical fiber, never stare into the end of a fiber connected to a laser source or LED.

3.2 Procedure.

Step 1 - Select MCP blocks in accordance with table 2B1-II.

Step 2 - Measure the length of the cable jacket to be removed:

For unterminated cables, measure the distance required to route OFCCs from innermost portion of the MCP completely around the interior of the interconnection box (or to the furthestmost connection point in the end user equipment), add approximately 130 mm (5 in) and mark the cable outer jacket.

MIL-STD-2042-2B(SH)

For terminated cable assemblies, measure the distance required to route OFCCs from innermost portion of the MCP to the furthestmost connection point in the equipment, add approximately 80 mm (3 in) and mark the cable outer jacket. In an interconnection box the distance measured shall be great enough that the OFCC can be routed one-half of the way around the box and then to the termination point.

Step 3 - Remove the outer jacket up to the mark using the cable stripper.

CAUTION: Do not cut or nick OFCCs.

Cut off the cable kevlar strength members and exposed central member, if present, using kevlar shears.

Step 4 - Remove the waterblocking material and clean the OFCCs using a wipe dampened with alcohol. Blow dry with air.

TABLE 2B1-II. MCP data and insert block sizes for optical fiber cables.

Cable type	4-fiber	8-Fiber	18-fiber	36-Fiber
Cable OD mm (in) nominal	8.1 (0.32)	11.1 (0.44)	14.3 (0.56)	20.8 (0.82)
Primary insert block part number M24705/1-BN	1508	2011	2014	3021
Alternate insert block part number M24705/1-BN	2008	N/A	N/A	N/A
Blanking insert block part number M24705/1-BN	15	20	20	30
Alternate blanking insert block part number M24705/1-BN	20	N/A	N/A	N/A

Step 5 - **CAUTION:** Do not exceed the cable minimum bend diameter of eight times cable OD for short term bends and sixteen times the cable OD for long term bends.

Feed the cables into the interconnection box or the other equipment through the cable penetration opening.

Step 6 - Liberally apply tallow to the outside portion of the insert blocks, the inner portion of the MCP frame and to the sides of the wedgepack. Make sure that tallow is placed in the corners of the MCP frame. (NOTE: The wedgepack may be removed and disassembled to apply the tallow.)

Step 7 - Reinstall the wedgepack (if removed) and install the insert blocks on the cables so that the outer jacket protrudes 13 mm (0.5 inch) to 25 mm (1 inch) inside the equipment. Install the cable insert blocks so that the gap between the insert block halves is parallel to the wedge pack. Install the insert blocks into the MCP frame so that the insert blocks are flush with the outside edge of the MCP frame. Fill all

MIL-STD-2042-2B(SH)

positions in the frame with insert blocks [either cable insert blocks or blanking (solid) insert blocks (see figure 2B1-1)]. (NOTE: Incoming cables may be installed on one end of the enclosure and outgoing cables on the opposite end for large enclosures. Where only one penetrator is used, incoming cables may be installed on one side of the wedgepack and outgoing cables on the opposite side.)

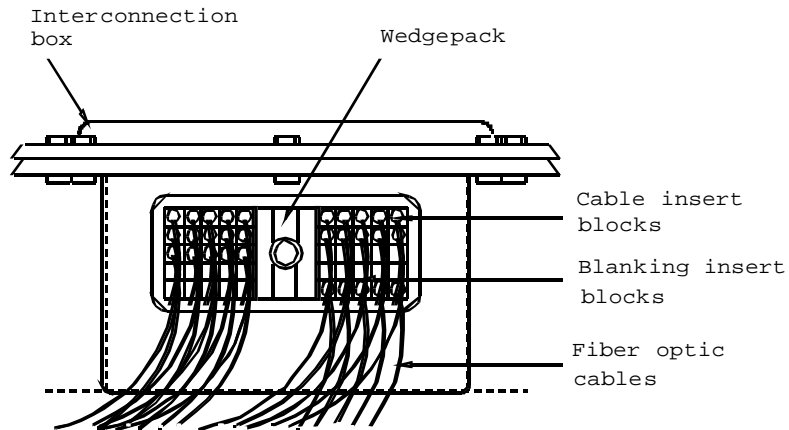

FIGURE 2B1-1. Interconnection box integral MCP - (typical).

- Step 8 - Tighten the nut on the wedgepack to compress the insert, until the outside wedge pack metal plate is almost flush with the bottom of the MCP frame blocks in the frame, using a wrench. (NOTE: The wedge pack is fully tightened when the length of the pack is the same as the depth of the MCP frame.) Continue to tighten the wedgepack nut until a torque between 5.7 and 16.9 N-m (50 and 150 in-lbs) is reached. After the blocks have been compressed for approximately 24 hours, retighten the nut to ensure that the seal is maintained.
- Step 9 - Install terminations on the OFCCs as specified on the system drawings using Part 5 of this standard practice.

MIL-STD-2042-2B(SH)

METHOD 2C1

CONVENTIONAL CABLE AND BUFFERED FIBER FORMING AND SHAPING

1. SCOPE.

1.1 Scope. This method describes a procedure for the forming and shaping of the optical fiber cable components (OFCC), loose tube furcation cables, and buffered fibers within an interconnection box or other equipment and installation of connectors and splices in patch panels and splice trays, respectively.

2. REQUIRED EQUIPMENT AND MATERIALS.

2.1 The equipment and materials in table 2C1-I shall be used to perform this procedure.

TABLE 2C1-I. Equipment and materials.

Description	Quantity
Safety glasses	1
Ruler	1
Self-clinching straps (SAE AS 23190 or equal)	As required
Lacing (Nylon or equal)	As required
Synthetic tubing	As required
Heat shrink tubing (SAE AMS-DTL-23053/5)	As required
Heat gun (Raychem 500B or equal)	1
Open end wrench	1
Alcohol bottle with alcohol/2-propanol	1
Wipes (NAVSEA DWG 6872812-18 or equal)	As required
Canned air (NAVSEA DWG 6872812-17 or equal)	As required

CAUTION: Throughout the fabrication process, cleanliness is critical to obtaining a high quality optical connection. Make sure that your hands and the work area are as clean as possible to minimize the ingress of dirt into the connections.

3. PROCEDURE.

3.1 Safety summary. The following safety precautions shall be observed:

- a. Safety glasses shall be worn at all times when handling bare fibers.
- b. Do not touch the ends of bare fiber. Wash hands thoroughly after handling bare fibers.

MIL-STD-2042-2B(SH)

- c. When visually inspecting an optical fiber, never stare into the end of a fiber connected to a laser source or LED.

3.2 Procedure.

3.2.1 Forming and shaping.

CAUTION: For equipment containing blown optical fiber tubes, do not disengage mated BOF tube couplers. Disengaging utilized BOF tube couplers may damage/break the optical fibers contained within the BOF tubes.

Step 1 - Verify that the procedures of Method 2A1 or Method 2B1 of this standard practice have been completed.

Step 2 - Open the enclosure cover and visually examine the OFCCs and loose tube furcation units for cuts, nicks, kinks or twists before forming them into groups.

Step 3 - **CAUTION:** Do not exceed the bend diameter of eight times the OFCC or loose tube furcation cable OD for short term bends and sixteen times the OFCC or loose tube furcation cable OD for long term bends.

Observe the connection configuration chart or other approved drawing and form the fibers into groups based on their final destination. Groups may then be formed into bundles and shaped using lacing or self-clinching straps in accordance with MIL-STD-2003-1, figures 1B5 and 1B6 respectively. Lace or strap the groups loosely; do not tighten down the straps with the hand tool.

Step 4 - Route the fiber bundles around the box securing them to the box mounting brackets using the self-clinching straps. Observe the following during routing (see figure 2C1-1):

- a. All OFCCs and loose tube furcation cables shall be routed one-half of the way around the box and then to the termination point.
- b. When a direct route to a termination point would exceed the OFCC or loose tube furcation cable long-term bend diameter of sixteen times the OFCC or furcation cable OD, an indirect route shall be used.
- c. Groups and bundles shall not cross the splice trays or patch panels or in any other way obstruct access to the individual connectors, splices or adapters. Groups and bundles may be routed between the splice tray or connector patch panel modules, if necessary.
- d. Groups and bundles shall be protected from possible damage by sharp edges by the use of supporting brackets or by synthetic tubing at the point of the sharp edge.

MIL-STD-2042-2B(SH)

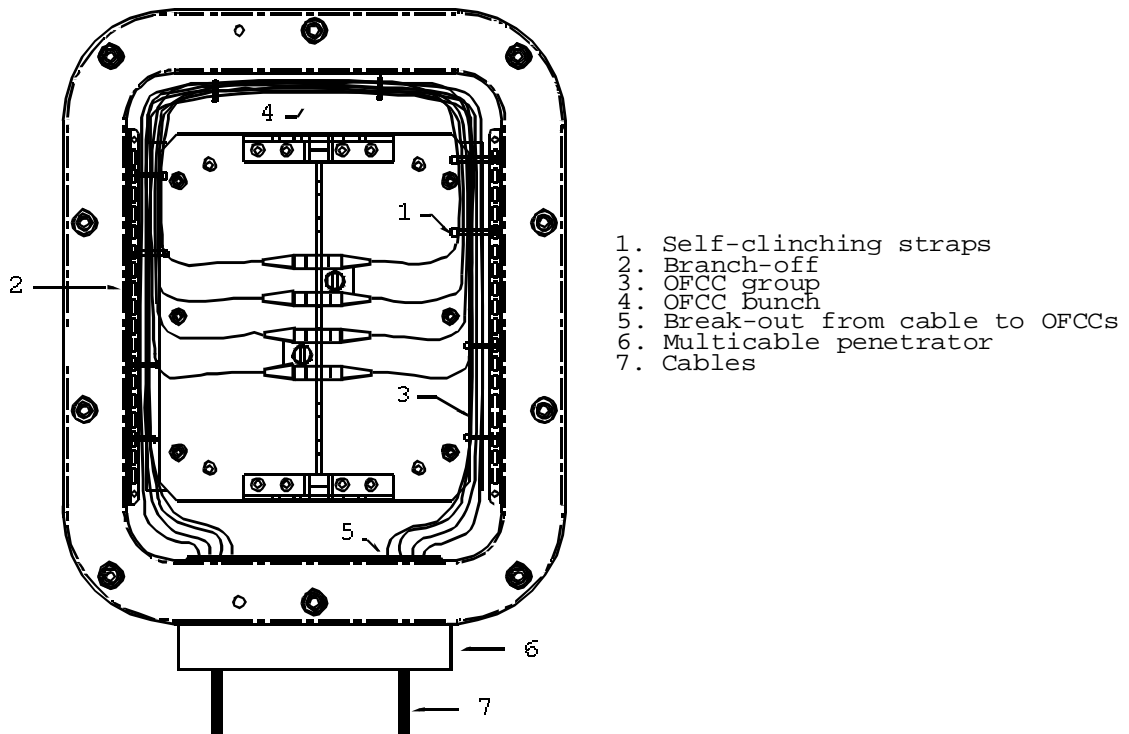
FIGURE 2C1-1. Forming and shaping - (typical).

Step 5 - Break out each separate OFCC or loose tube furcation cable from the group or bundle and, if not already done, slide the heat shrink tubing with the fiber identification over the connector or splice onto the OFCC or loose tube furcation cable jacket.

NOTE: The heat shrink tubing should normally be pushed up the OFCC or loose tube furcation cable before the OFCC or loose tube furcation cable is terminated. If the heat shrink is not put on before the connector or splice, heat shrink is available that can be installed after the connector or splice is installed.

NOTE: Do not install heat shrink tubing on 900-micron fibers. In those cases where 900-micron fiber is present going into a splice, the shrink tubing should be installed in a region where there is an OFCC.

Step 6 - **CAUTION:** Do not overheat the OFCC or loose tube furcation cable. Prolonged exposure of the OFCC or loose tube furcation cable jacket to temperatures in excess of 160 degrees Celsius ($^{\circ}\text{C}$) [320 degrees Fahrenheit ($^{\circ}\text{F}$)] may damage the OFCC or furcation cable jacket. Discontinue heating of the tubing and allow the OFCC or loose tube furcation cable jacket to cool before reheating if the OFCC or furcation cable jacket shows any signs of bubbling.

Holding the heat gun approximately 100 mm (4 in) away from the OFCC or loose tube furcation cable and tubing, shrink the tubing.

MIL-STD-2042-2B(SH)

Step 7 - Form the unterminated OFCC bundles into a loop around the complete interior of the box being careful not to kink or otherwise damage the OFCCs and end seal the bundles in accordance with Method 1A1 of this Standard practice. Tie off the unterminated bundles such that they will not obstruct access to other components.

NOTE: Do not group or bundle the unterminated OFCCs with the terminated OFCCs or loose tube furcation cables. Unterminated OFCCs should be independently grouped, bundled and strapped to the box mounting brackets from the terminated OFCCs.

NOTE: Unterminated loose tube furcation cables shall be individually end sealed in accordance with Method 1E1 of this standard practice.

Step 8 - Proceed to 3.2.2 below to install connectors in patch panels. Proceed to 3.2.3 below to install splices in splice trays.

3.2.2 Connector installation in patch panel.

Step 1 - Unscrew the two screws holding the patch panel and pull the panel forward until it catches in the slide. (NOTE: The panel can be completely removed by pulling it through the catch.)

NOTE: Use a wipe dampened with alcohol to clean all connectors and blow them dry with air before making connections.

Step 2 - Insert one connector into the adapter mounted in the patch panel and lock it into place with the bayonet fitting. (This is accomplished by aligning the key on the connector barrel with the keyway on the adapter, inserting the connector in the adapter, engaging the bayonet coupling mechanism and rotating the connector clockwise until it stops.)

Step 3 - Insert the mating connector into the opposite side of adapter and lock it into place.

Step 4 - Repeat steps 2 and 3 above until all of the connectors are installed. Push the panel back into the box and tighten the screws.

Step 5 - Close and secure the enclosure cover using a wrench.

3.2.3 Splice installation in splice tray. This procedure is only applicable for specific systems previously designed utilizing MIL-PRF-24623/4 splices.

Step 1 - Unscrew the four screws holding the splice tray holder cover, pull the splice tray forward and remove it from the holder. Remove the splice tray cover (if applicable).

Step 2 - Place the ends of splice compression tool into the slots on the splice ferrule collars and squeeze the tool to compress the ferrule springs (see figure 2C1-2).

MIL-STD-2042-2B(SH)

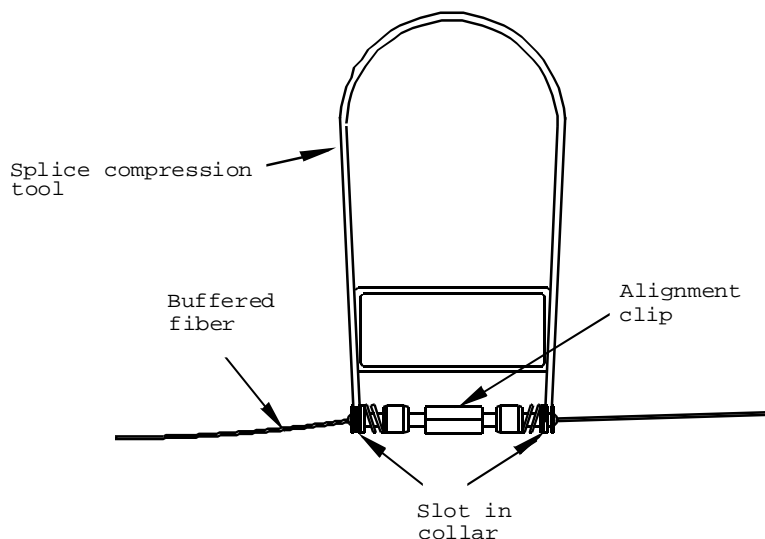
FIGURE 2C1-2. Compressing ferrule springs.

Step 3 - Carefully place the splice into the splice tray with the open slot in the splice alignment sleeve facing upward (see figure 2C1-3). Ensure the ferrule ends are completely seated in the tray and that the buffered fibers are carefully routed in the tray slots.

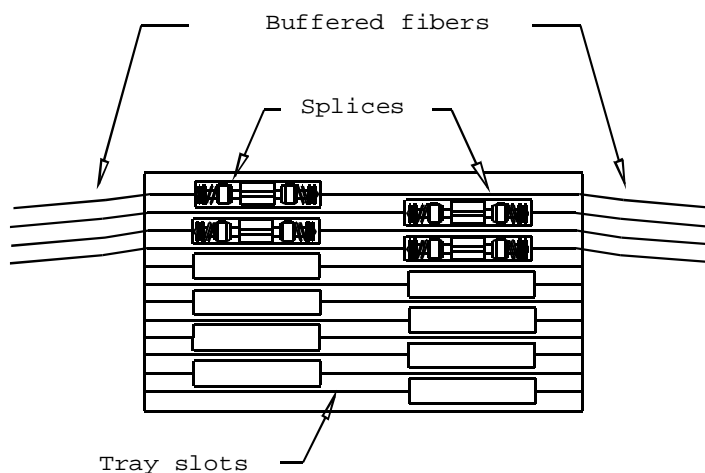
FIGURE 2C1-3. Splices installed in splice tray - (typical).

Step 4 - Repeat steps 2 and 3 above until all of the splices are installed in the tray. Place the splice tray cover over the splice tray and reinstall the tray into the holder. Repeat the above procedures for each tray, as required.

Step 5 - Replace the tray holder cover and tighten the holder cover screws.

Step 6 - Close and secure the enclosure cover using a wrench.

MIL-STD-2042-2B(SH)

METHOD 2D1

SPLICE ASSEMBLY AND ALIGNMENT

1. SCOPE.

1.1 Scope. This method describes a procedure for mating and aligning optical fibers terminated with MIL-PRF-24623/4 splice ferrules to form a continuous optical signal path. This method is only applicable for specific systems previously designed utilizing MIL-PRF-24623/4 splices.

2. REQUIRED EQUIPMENT AND MATERIALS.

2.1 The equipment and materials in table 2D1-I shall be used to perform this procedure.

TABLE 2D1-I. Equipment and materials.

Description	Quantity
Safety glasses	1
Index matching gel (MIL-M-24794)	As required
Alignment clip tool (NAVSEA DWG 6872812-01 or equal)	1
Splice alignment tool (NAVSEA DWG 6872812-05 or equal)	1
Test jumpers (in accordance with table 6C1-III in Part 6 of this standard practice)	As required
Optical loss test set (NSN 7Z 6625 01 304 1739) or equal	1
Alcohol bottle with alcohol/2-propanol	1
Wipes (NAVSEA DWG 6872812-18 or equal)	As required

CAUTION: Throughout the fabrication process, cleanliness is critical to obtaining a high optical quality connection. Make sure that your hands and the work area are as clean as possible to minimize the ingress of dirt into the splice.

3. PROCEDURE.

3.1 Safety summary. The following safety precautions shall be observed:

- a. Safety glasses shall be worn at all times when handling bare fibers.
- b. Do not touch the ends of the fiber. Wash your hands thoroughly after handling bare fibers.
- c. When visually inspecting an optical fiber, never stare into the end of a fiber connected to a laser source or LED.

MIL-STD-2042-2B(SH)

3.2 Procedure.

3.2.1 Splice assembly.

Step 1 - Mix a small portion of the index matching gel on a clean surface according to the manufacturer's instructions provided (vacuuming is not required).

NOTE: The index matching gel provided may be a one-part gel that does not require mixing.

Step 2 - CAUTION: Opening the sleeve too much may damage the sleeve.

Adjust the splice alignment clip tool so that it opens the splice alignment clip just enough to insert the splice ferrules. Insert the tool tip into the alignment sleeve slot. Open the sleeve (see figure 2D1-1).

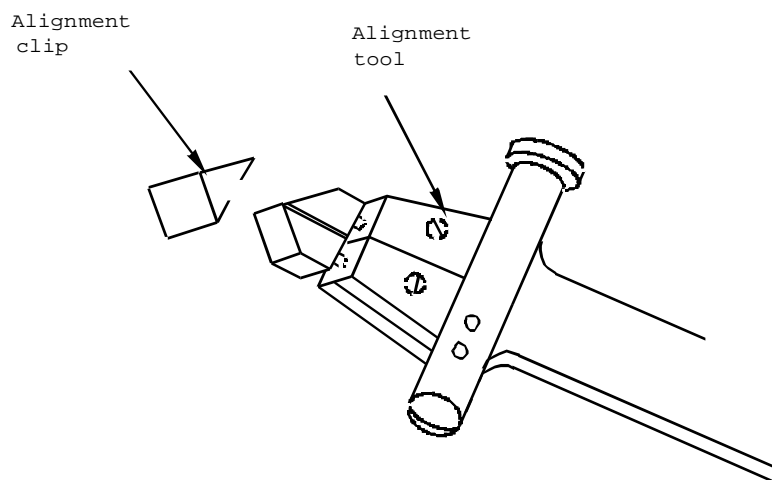
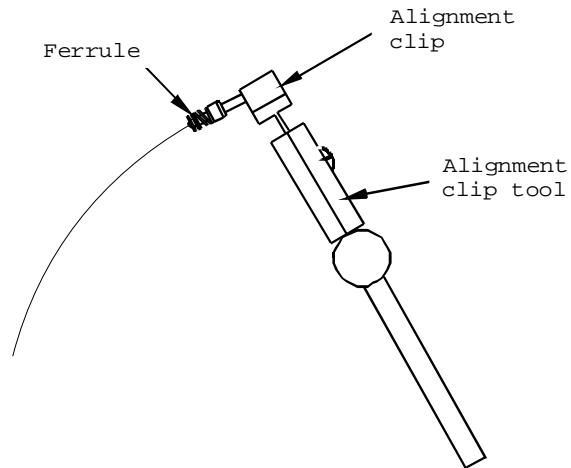

FIGURE 2D1-1. Opening alignment sleeve.

Step 3 - Dip one of the polished ferrule tips into the index matching gel and slide the ferrule into the alignment clip until the tip is approximately centered in the clip (see figure 2D1-2).

MIL-STD-2042-2B(SH)

FIGURE 2D1-2. Inserting ferrule into alignment sleeve.

Step 4 - Dip the other ferrule tip into the index matching gel and slide the ferrule tip into the other side of the alignment clip (see figure 2D1-3). Ensure that the ferrule tips are centered in the alignment clip and the alignment tabs are facing the clip gap. Remove the alignment clip tool from the alignment clip. Verify that the ferrule tips are in contact by pushing the ferrules together.

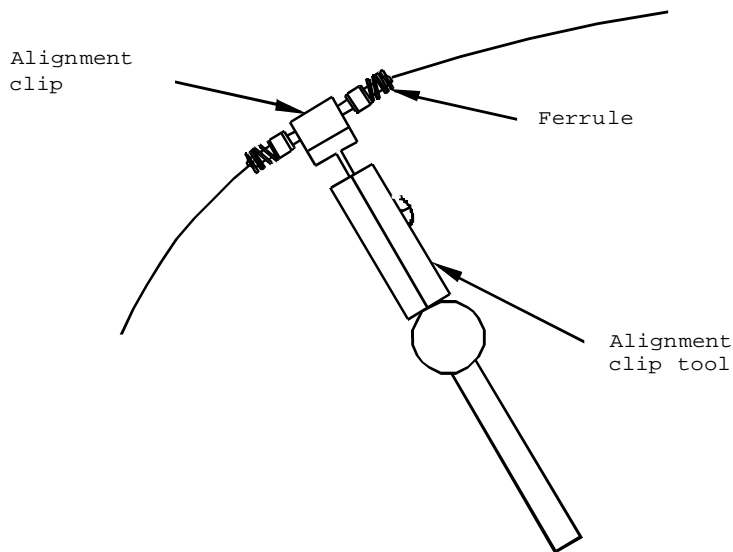
FIGURE 2D1-3. Inserting second ferrule into alignment sleeve.

3.2.2 Splice alignment.

NOTE: Passive alignment should be sufficient for most applications. Active alignment shall only be performed when required to meet link acceptance requirements.

MIL-STD-2042-2B(SH)

Proceed to step 1 below for passive alignment or proceed to step 2 below for active alignment.

- Step 1 - Passive alignment - verify the tab alignment by inserting the splice assembly into the splice alignment tool making sure the tabs fit into the tool slots (see figure 2D1-4). If necessary, rotate either ferrule slightly to align the tabs. Remove the splice from the tool.

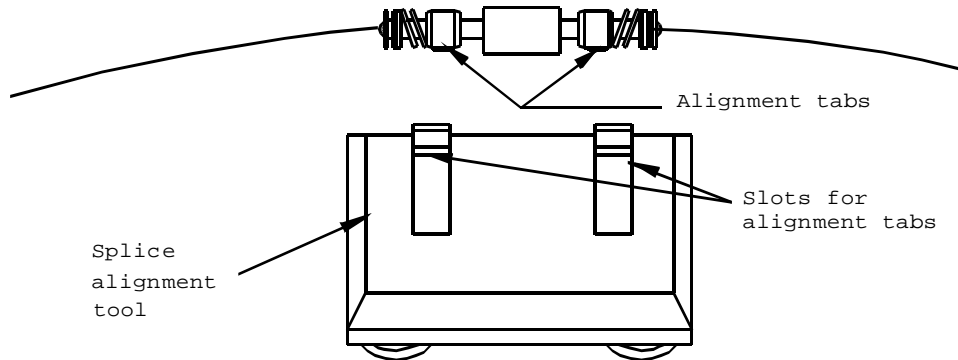

FIGURE 2D1-4. Aligning tabs.

- Step 2 - Active alignment -

WARNING: Do not stare into the end of a fiber connected to an LED or laser diode. Light may not be visible but can still damage the eye.

Using the appropriate test adapters or test jumper cables in accordance with table 6C1-III in Part 6 of this standard practice, connect the cable ends opposite the splice ferrules of cable under test to the light source and detector of two optical loss test sets and energize both (see figure 2D1-5).

- NOTE: Both optical loss test sets should be allowed to warm up before starting the active alignment so that the readings are stable.

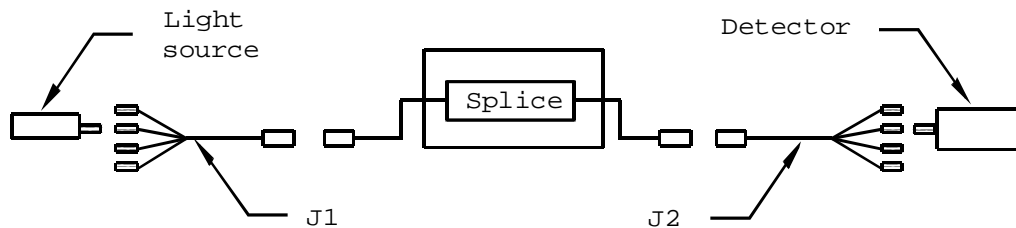

FIGURE 2D1-5. Active splice alignment cable hookup.

- Step 3 - Rotate the ferrules relative to each other until the maximum power is recorded at the optical detector. De-energize the optical loss test sets.

MIL-STD-2042-2B(SH)

METHOD 2E1

BOF TUBE FURCATION UNIT FABRICATION

1. SCOPE

1.1 Scope. This method describes the procedure for fabricating tube furcation units that will separate either individual BOF fibers or BOF bundles, within a tube, into individual single fiber cables, so that they may be terminated using the same methods and materials as traditional (OFCC-type) cables. This procedure may be used to fabricate tube furcation units for four to twelve optical fibers.

NOTE: Furcation units in accordance with A-A-59729 may be used.

2. REQUIRED EQUIPMENT AND MATERIALS.

2.1 The equipment and materials in the tables located in the applicable sections of this method shall be used to perform these procedures.

3. PROCEDURES

3.1 Safety summary. The following safety procedures shall be observed:

- a. Observe warnings and cautions on equipment and materials.
- b. Safety glasses shall be worn at all times when handling bare fibers or dispensing adhesive.
- c. Avoid skin contact with adhesives.
- d. Do not touch the ends of the fiber, as they may be razor sharp. Wash your hands after handling bare fiber.

3.2 Procedure.

3.2.1 The equipment and materials in Table 2E1-I shall be used to perform this procedure.

TABLE 2E1-I. Equipment and materials.

Description	Quantity
Safety glasses	1
Ruler	1
Polyethylene tubing with 9.5 mm (0.375 in) ID (for 4 and 6 fiber tube furcation unit)	As required
Polyethylene tubing with 12.7 mm (0.5 in) ID (for 8 and 12 fiber tube furcation units)	As required
BOF polyethylene tubing (8.0 mm OD) or equal	As required
Heat shrink sleeve (Raychem SST-FR series or equal)	As required
Heat gun (Raychem 500B or equal)	1
Slate colored loose tube furcation cable (Northern Lights Cable LSZH-FT-650x900x2.4mm/HY/SP/SL or equal)	As required

MIL-STD-2042-2B(SH)

TABLE 2E1-I. Equipment and materials - continued.

Description	Quantity
Yellow colored loose tube furcation cable (Northern Lights Cable LSZH-FT- 650x900x2.4mm/HY/SP/YL or equal)	As required
Color coding materials	As required
Two-part epoxy (Devcon P/N 14250 or equal)	1
Kevlar shears (NAVSEA DWG 6872811-16 or equal)	1
OFCC strip tool (NAVSEA DWG 6872811-10 or equal)	1
Tube cutter	1
Scissors	1
Silicone caulking compound in standard caulking tube (CID A-A-00272 or equal)	As required
Caulking gun	1
Rubber gloves	1 pair
Alcohol bottle with alcohol/2-propanol	1
Wipes (NAVSEA DWG 6872811-18 or equal)	As required
Razor blade	1
Fiber, 500 micrometer outer diameter	As required
Tube coupler (AA59731-U-8 or AA59731-U-8E)	1
Pressure source with 8 mm OD tube outlet	1

Step 1 - Using the kevlar shears, cut the required number of loose tube furcation cables to the required length.

NOTE: Slate colored loose tube furcation cable is used for furcation units for multimode optical fiber. Yellow colored loose tube furcation cable is used for furcation units for single mode optical fiber.

NOTE: The exact length of the loose tube furcation cable depends upon the equipment and the furcation cable routing. This length may be determined by measuring the distance required to route the loose tube furcation cables from the end of the BOF tube to the furthestmost connection point in the equipment plus approximately 130 mm (5 in). Alternatively, standard length furcation units (1.0 m, 1.5 m, 2.0 m, etc.) may be fabricated and cut to the appropriate length during equipment installation.

Step 2 - Using the tube cutter, cut the following items to the identified lengths:

- a. 38.0 mm (1.5 inch) length of polyethylene tube.
- b. 76.0 mm (3.0 inch) length of BOF tube.
- c. 76.0 mm (3.0 inch) length of heat shrink tubing.

NOTE: Clean the end of the polyethylene tube and the BOF tube with a wipe dampened with alcohol and blow dry as necessary.

MIL-STD-2042-2B(SH)

- Step 3 - Insert the loose tube furcation cables into the polyethylene tube and slide the tube approximately 30 cm (12 in) down the furcation cables.
- Step 4 - Using the OFCC strip tool, trim back the loose tube furcation cable jackets approximately 100 mm (4 in) exposing the kevlar and buffer tubes. Arrange all of the loose tube furcation cables together and evenly align them with each other (see figure 2E1-1).

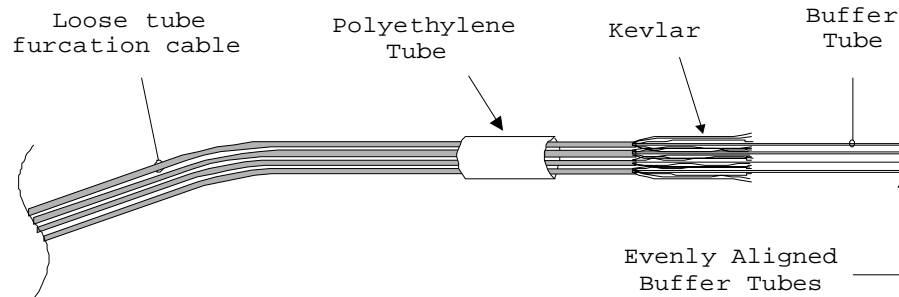

FIGURE 2E1-1. Aligning the loose tube furcation cables.

- Step 5 - Slide the polyethylene tube up the loose tube furcation cables until it is approximately 25 mm (1.0 inch) from the end of the furcation cable jacket. Ensure that the trimmed portions of the loose tube furcation cables are still aligned with each other.
- Step 6 - Thoroughly mix the two parts of the epoxy together and apply the epoxy to the end 19 mm (0.7 in) of the loose tube furcation cable jackets.
- NOTE: Only a light coating of epoxy is required. Make sure that epoxy is applied to all furcation cable jackets.
- Step 7 - Carefully move the polyethylene tube over the epoxy covered loose tube furcation cables until the ends of the furcation cable jackets are centered approximately between the ends of the polyethylene tube. Fold back the kevlar strands over the polyethylene tube (see figure 2E1-2).

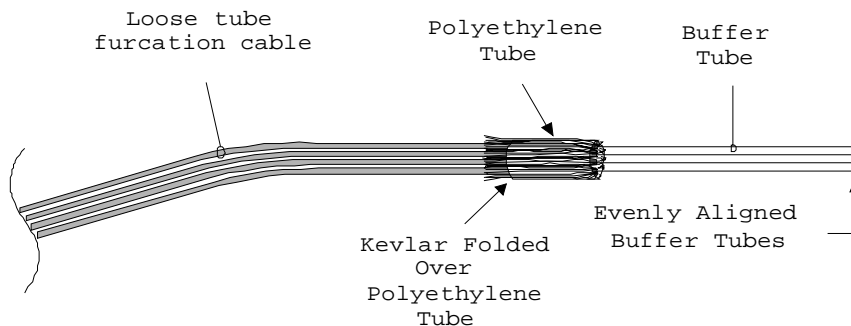

FIGURE 2E1-2. Folding back the kevlar.

- Step 8 - Still holding the loose tube furcation cable and polyethylene tube assembly, insert the exposed furcation cable buffer tubes into the BOF tube. Slide the BOF tube to the edge of the polyethylene tube.
- Step 9 - Apply epoxy to approximately 19.0 mm (0.75 inch) of the BOF tube end closest to the polyethylene tube. Insert the BOF tube into the

MIL-STD-2042-2B(SH)

polyethylene tube until the BOF tube butts against the jackets of the loose tube furcation cables. Ensure that approximately 12.7 mm (0.5 inch) of the loose tube furcation cable buffer tubes are protruding from the end of the BOF tube (see figure 2E1-3).

NOTE: Only a light coating of epoxy is required.

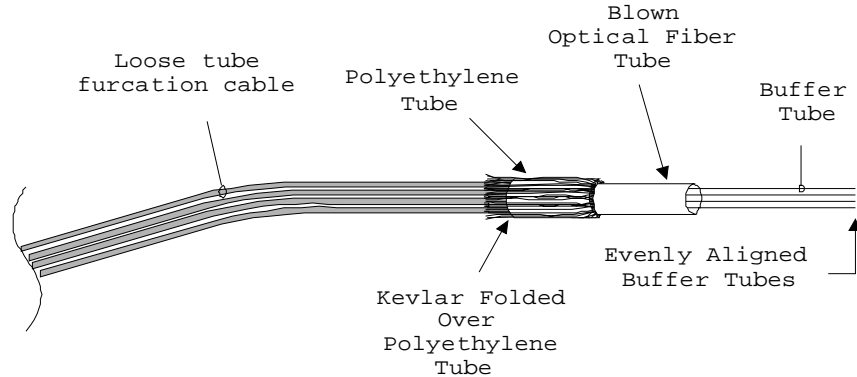

FIGURE 2E1-3. Furcation cables joined to the BOF tube.

Step 10 -Allow the assembly to set until the epoxy hardens.

Step 11 -With the kevlar shears, trim the kevlar strands even with the rear end of the polyethylene tube. Thoroughly mix the two parts of the epoxy together and apply epoxy to the polyethylene tube. Evenly distribute the kevlar strands around the polyethylene tube and fold them flat against the tube sides.

NOTE: Only a light coating of epoxy is required.

Step 12 -While the epoxy is still wet, slide the heat shrink tube over the BOF tube and the polyethylene tube. Center the heat shrink tube over the polyethylene tube. Ensure that the heat shrink tube covers at least 12.7 mm (0.5 inch) of the loose tube furcation cables and BOF tube.

Step 13 -**CAUTION:** Do not overheat the loose tube furcation cables. Prolonged exposure of the loose tube furcation cable jackets to temperatures above 160°C (320°F) may damage the furcation cable jackets. Discontinue heating of the sleeve and allow the loose tube furcation cable jackets to cool before reheating if the furcation cable jackets show any signs of bubbling.

Holding the heat gun approximately 100 mm (4 in) away, heat evenly from the center to the ends around the entire sleeve. Heat until the tube has shrunk to a snug fit around the complete assembly (see figure 2E1-4).

MIL-STD-2042-2B(SH)

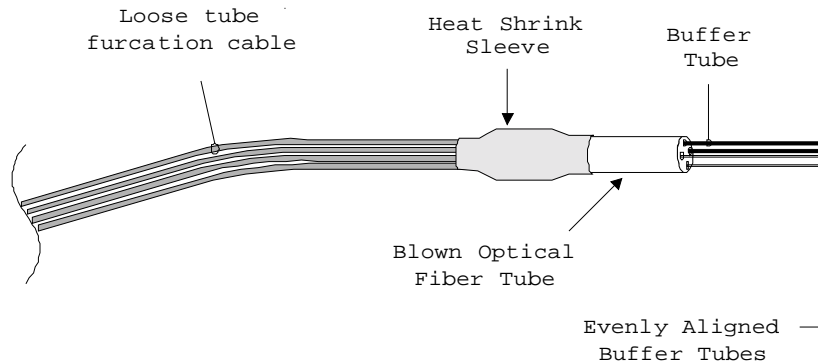
FIGURE 2E1-4. Completed assembly.

- Step 14 -Place the caulking compound tube nozzle into the end of the BOF tube. Inject the caulking compound so that it completely fills a 12.7 mm (0.5 inch) length of the tube (as a minimum). Carefully work the exposed loose tube furcation cable buffer tubes around within the caulking compound so that there are no voids. Arrange the buffer tubes so that they are approximately centered in the BOF tube. Clean any excess caulking compound from the tube with a wipe.
- Step 15 -Allow the caulking compound to cure for 72 hours.
- Step 16 -Using the razor blade, carefully cut off the exposed ends of the loose tube furcation cable buffer tubes even with the end of the BOF tube.
- Step 17 -Verify the integrity of each loose tube furcation cable buffer tube in the completed furcation unit:
- Insert the 500-micron fiber through each loose tube furcation cable buffer tube until it exits out the other end of the tube.
- Step 18 -Connect the furcation unit to a 234 kPa (34 PSI) pressure source using a tube coupler. Maintain the connection for a minimum of 30 seconds. Verify that there is no leakage of air from the furcation unit body.
- NOTE: Leakage may be checked by immersing the furcation unit body in water and visually inspecting for air bubbles. The ends of the loose tube furcation cables should not be immersed.

MIL-STD-2042-2B(SH)

METHOD 2F1

BOF TUBE FURCATION UNIT INSTALLATION

1. SCOPE

1.1 Scope. This method describes the procedure for installing the individual BOF fibers, or fibers within BOF bundles, into a furcation unit.

2. REQUIRED EQUIPMENT AND MATERIALS.

2.1 The equipment and materials in the tables located in the applicable sections of this method shall be used to perform these procedures.

3. PROCEDURES

3.1 Safety summary. The following safety procedures shall be observed:

- a. Observe warnings and cautions on equipment and materials.
- b. Safety glasses shall be worn at all times when handling bare fibers or dispensing adhesive.
- c. Do not touch the ends of the fiber as they may be razor sharp. Wash your hands after handling bare fiber.
- d. When visually inspecting an optical fiber, never stare into the end of a fiber connected to a laser source or LED.

3.2 Procedure.

3.2.1 The equipment and materials in table 2F1-I shall be used to perform this procedure.

TABLE 2F1-I. Equipment and materials.

Description	Quantity
Safety glasses	1
Tapered tube plug (6 fiber bundle, 2 to 6 individual fibers) (AA59730-TTP-2)	As required
Tapered tube plug (12 or 18 fiber bundle, 8 to 12 individual fibers) (AA59730-TTP-3)	As required
Adhesive and sealant tape (Raychem SFTS-1 or equal)	As required
Ruler	1
Utility knife	1
Tube cutter	1
Bundle jacket stripper (18 gauge for 6-fiber bundles)	1
Bundle jacket stripper (12 gauge for 18-fiber bundles)	1
Clear jacket stripper (20 gauge for 6-fiber bundles)	1

MIL-STD-2042-2B(SH)

TABLE 2F1-I. Equipment and materials (continued).

Description	Quantity
Scissors	1
Fiber, BOF single fibers or fibers from a BOF bundle	As required
Furcation Unit (per A-A-59729 or fabricated per Method 2E1 of this standard)	As required
Straight tube coupler (AA59731-U-8 or AA59731-U-8E)	As required
Tee tube coupler (AA59731-T-8 or AA59731-T-8E)	As required
BOF tubing (8.0 mm OD)	As required
Wipes (NAVSEA DWG 6872811-18 or equal)	As required
Colored tubing or tape	As required

NOTE: Previously used BOF tube couplers may not adequately seal to BOF tubes. When installing BOF cabling, always use new BOF tube couplers.

NOTE: Before mating BOF tubes to BOF tube couplers, clean the end of each BOF tube with a wipe dampened with alcohol and blow dry as necessary.

3.2.2 Tube preparation. The BOF tubes shall be prepared as described below, unless otherwise approved by the Naval Surface Warfare Center (see 1.1.1), before installation of the BOF furcation unit.

NOTE: Refer to the connection chart or other approved drawing to determine where to use straight tube couplers and where to use tee tube couplers.

Step 1 - Insert the individual fibers or bundle into the tube coupler. Slide the tube coupler over the fibers to the BOF tube. Slide the tube coupler onto the BOF tube and firmly seat the tube within the tube coupler.

Step 2 - Using the scissors, trim back the individual fibers or fiber bundle that exit the tube coupler to approximately 66 cm (26.0 in) longer than the required length.

NOTE: The exact length of the BOF fiber or fiber bundle depends upon the equipment and the fiber routing. This length may be determined by measuring the distance required to route the fiber from the end of the BOF tube to the furthestmost connection point in the equipment plus approximately 130 mm (5 in).

Step 3 - For tubes containing BOF bundles only:

NOTE: For eighteen fiber bundles, fibers of the same color are contained in each 6-fiber subunit. During the installation of the furcation unit, it is necessary to know the 6-fiber subunit that each fiber comes from. One method to uniquely mark the fibers of each 6-fiber subunit is to make the fibers of each subunit a slightly different length.

a. Optional step for 18-fiber bundles: Using the scissors, cut off approximately 100 mm (4 in) of the fibers of one 6-fiber subunit. Then cut off approximately 200 mm (8 in) of the fibers in a different 6-fiber subunit.

b. Mark the bundle jacket approximately 25 mm (1.0 in) from the tube coupler.

MIL-STD-2042-2B(SH)

- NOTE: Do not pull slack fiber bundle out of the BOF tube while breaking out the bundle fibers. If slack fiber bundle is accidentally pulled out of the BOF tube, re-establish the bundle to its original position (using the mark on the bundle jacket) and continue the procedure.
- c. Using the bundle jacket stripper, remove the bundle jacket in approximately 160 mm (6 inch) lengths back to the mark.
- NOTE: Once a short length of the bundle jacket has been removed, the remaining length can be torn off of the bundle by hand.
- d. Using the clear jacket stripper, remove approximately 80 mm (3.0 in) of the clear inner jacket from the end of each 6-fiber subunit.
- NOTE: If the clear jacket stripper does not bite into the clear inner jacket, position the clear jacket stripper at a 30 to 40 degree angle to increase its bite.
- e. Find the ripcord from among the six fibers. Ensure that it is not crossed with any of the fibers. While holding the group of fibers in one hand, pull the ripcord along the bundle with the other hand. Pull the ripcord until it reaches the mark on the bundle jacket.
- NOTE: The ripcord and fibers spiral along the bundle length. Take care to follow the spiral when pulling the ripcord.
- f. Starting at the end of the fiber bundle subunit, carefully pull the group of fibers from the clear inner jacket.
- g. Using the scissors, carefully cut away the ripcord and the clear inner jacket.
- Step 4 - Using the tube cutter, cut a piece of BOF tube a minimum of 80 mm (3 inch) in length. Visually verify that both ends of the tube are cut perpendicular to the tube length. Clean the ends of the BOF tube with a wipe dampened with alcohol and blow dry as necessary.
- NOTE: When tube furcation units with removable BOF tubes are utilized, the removable tube from the tube furcation unit may be utilized as the 80 mm (3 inch) BOF tube.
- Step 5 - Insert the individual fibers into the short piece of BOF tube. Slide the short piece of BOF tube over the fibers to within approximately 51 mm (2.0 in) of the tube coupler.
- Step 6 - For tubes containing BOF bundles only:
- a. Place the appropriate tapered tube plug around the exposed bundle jacket approximately 19 mm (0.75 inch) from the BOF tube coupler.
- NOTE: The tapered tube plug should be oriented with the tapered end of the plug towards the short piece of BOF tube.
- b. Push the short piece of BOF tube over the tapered tube plug until the plug is fully inserted into the BOF tube.
- NOTE: Do not pull slack fiber bundle out of the BOF tube while assembling the plug to the bundle jacket and the short piece of BOF tube. If slack fiber bundle is accidentally pulled out of the BOF tube, re-establish the bundle to its original position and continue the procedure.
- Step 7 - For tubes containing individual BOF fibers only:

MIL-STD-2042-2B(SH)

- a. Work a small amount of sealant tape around the optical fibers approximately 19 mm (0.75 inch) from the end of the BOF tube.
- b. Place the appropriate tapered tube plug around the optical fibers and sealant tape.

NOTE: The tapered tube plug should be oriented with the tapered end of the plug towards the short piece of BOF tube.

- c. Push the short piece of BOF tube over the tapered tube plug until the plug is fully inserted into the short piece of BOF tube.

NOTE: Do not pull slack fiber out of the BOF tube while assembling the plug to the individual fibers and the short piece of BOF tube. If slack fiber is accidentally pulled out of the BOF tube, re-establish the fibers to their original position and continue the procedure.

Step 8 - Using the scissors, trim the flange on the tapered tube plug even with the outer diameter of the short piece of BOF tube.

Step 9 - Slide the short piece of BOF tube with the tapered tube plug into the tube coupler and firmly seat the tube within the tube coupler (see figure 2F1-2). Apply an axial load of approximately 22 N (5 lbs) between the two BOF tubes to verify that the tube coupler is properly engaged onto the tubes.

NOTE: The optical fibers should now be fixed in the tapered tube plug and should not move into or out of the BOF tube during the furcation unit installation or fiber termination process.

NOTE: When a tee tube coupler is used, the tee connection is end sealed after conduct of the tube sealing integrity test.

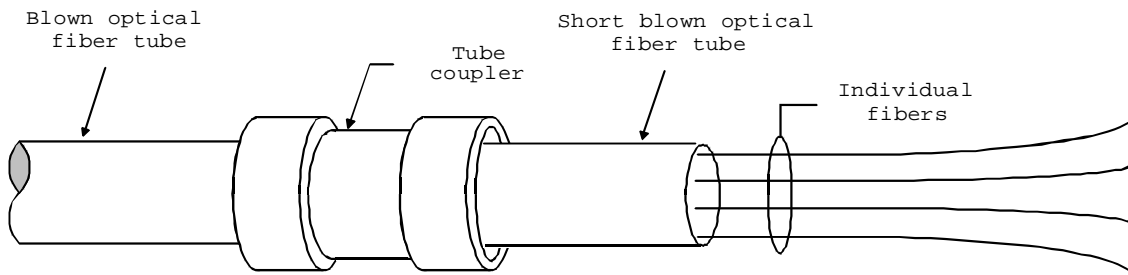

FIGURE 2F1-2. Short BOF tube and fibers.

Step 10 -When a tee tube connection is used, one of the following optional steps may be performed:

- option a. Using the tube cutter, cut a short piece of BOF tubing (length as necessary to allow easy access). Visually verify that the ends of the tube are cut perpendicular to the tube length. Clean the ends of the short piece of BOF tube with a wipe dampened with alcohol and blow dry as necessary. Slide the short tube into the tee position of the tee tube coupler. Firmly seat the short BOF tube into the tee tube coupler. Apply an axial load of approximately 22 N (5 lbs) between the BOF tube and the tee tube coupler to verify that it is properly engaged into the tube coupler.
- option b. Clean a pressure valve assembly with a wipe dampened with alcohol and blow dry as necessary. Slide the pressure valve assembly into the tee position of the tee tube coupler. Firmly seat the

MIL-STD-2042-2B(SH)

pressure valve assembly into the tee tube coupler. Apply an axial load of approximately 22 N (5 lbs) between the pressure valve assembly and the tee tube coupler to verify that it is properly engaged into the tube coupler.

- option c. Clean a tube fitting plug with a wipe dampened with alcohol and blow dry as necessary. Slide a tube fitting plug into the tee position of the tee tube coupler. Apply an axial load of approximately 22 N (5 lbs) between the tube fitting plug and the tee tube coupler to verify that it is properly engaged into the tube coupler.

Step 11 - Proceed to Step 1 of 3.2.3.

3.2.3 Furcation installation.

Step 1 - Insert the individual fibers into a tube coupler. Slide the tube coupler over the fibers to the short piece of BOF tube. Slide the tube coupler onto the short piece of BOF tube and firmly seat the tube within the tube coupler (see figure 2F1-3).

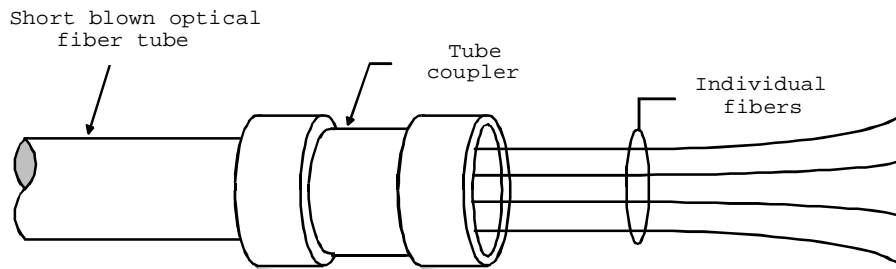

FIGURE 2F1-3. BOF tube and fibers.

NOTE: When the BOF tube from a tube furcation unit with a removable tube is utilized for the 80 mm (3 inch) BOF tube, this step is not required.

Step 2 - Insert each individual fiber into one of the loose tube furcation cable buffer tubes within the furcation unit (see figure 2F1-4). Feed each fiber through the furcation unit until all of the fibers are protruding from the ends of the individual loose tube furcation cables.

NOTE: Use furcation units identified with a slate color for BOF tubes containing multimode optical fiber. Use furcation units identified with a yellow color for BOF tubes containing single mode optical fiber.

NOTE: Furcation units utilized should have a furcation cable for each of the fibers in the BOF tube. If the number of fibers in the BOF tube exceeds the number of furcation cables, the additional fibers may be cut off after all of the required fibers are successfully installed through their furcation cables.

MIL-STD-2042-2B(SH)

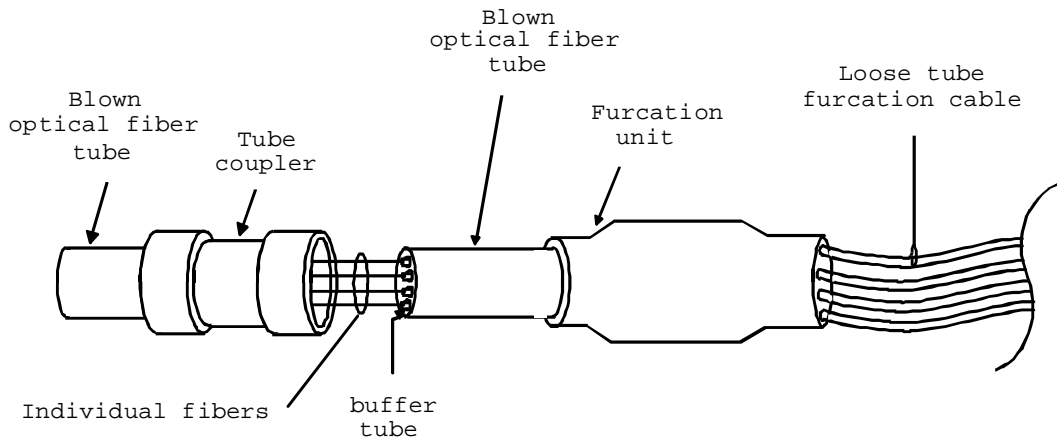
FIGURE 2F1-4. Feeding fibers into the furcation unit.

- Step 3 - Carefully insert the furcation unit tube into the tube coupler and firmly seat the tube within the tube coupler (see figure 2F1-5). Ensure that no fibers are kinked within the tube as it is inserted into the tube coupler. Apply an axial load of approximately 22 N (5 lbs) between the BOF tube and the furcation unit to verify that they are properly engaged into the tube coupler.

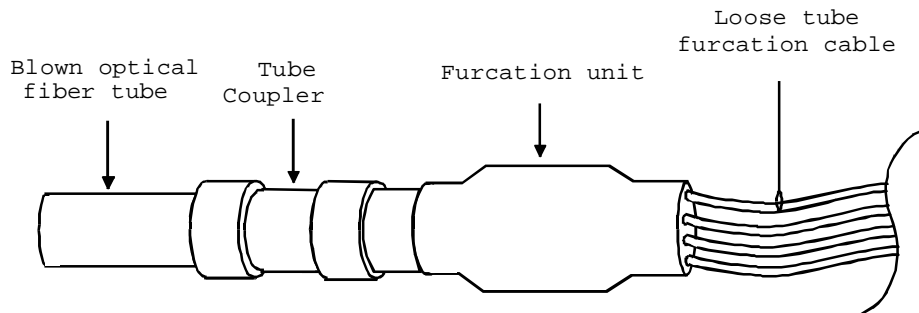
FIGURE 2F1-5. Installed furcation unit.

NOTE: Do not rotate the furcation unit with respect to the BOF tube cable. Rotation of the furcation unit may cause increased optical loss or fiber breakage.

- Step 4 - Mark each loose tube furcation cable to identify the color/number of the fiber within that furcation cable. Refer to table 2F1-2 for fiber color coding.

NOTE: If marking the color of the fiber within each loose tube furcation cable, colored heat shrink tubing or tape may be used.

MIL-STD-2042-2B(SH)

TABLE 2F1-II. Fiber color coding.

Fiber number	General Cable fiber color	Sumitomo Electric fiber color		
		12-fiber bundle	18-fiber bundle	
			Subunit color (See Note)	Fiber color
1	Blue	Blue	Red	Blue
2	Orange	Orange		Orange
3	Green	Green		Green
4	Brown	Brown		Brown
5	Slate	Slate		Slate
6	White	White		Red
7	Red	Red	Violet	Blue
8	Black	Black		Orange
9	Yellow	Yellow		Green
10	Violet	Violet		Brown
11	Pink	Pink		Slate
12	Aqua	Aqua		Violet
13	N/A	N/A	Yellow	Blue
14	N/A	N/A		Orange
15	N/A	N/A		Green
16	N/A	N/A		Brown
17	N/A	N/A		Slate
18	N/A	N/A		Yellow

NOTE: The subunits of the 18-fiber bundles do not have color coded subunit jackets. The subunit color is determined by the presence of red, violet or yellow colored fiber within the subunit.

Step 5 - Slide the heat shrink tubing with the furcation unit identification over the furcation unit loose tube furcation cables onto the furcation unit body. Holding the heat gun approximately 100 mm (4 in) away from the furcation unit, shrink the shrink tubing.

Step 6 - End seal any furcation cables that will not be terminated in accordance with Method 1E1 of this standard.

MIL-STD-2042-2B(SH)

METHOD 2G1

BOF CABLE ENTRANCE TO EQUIPMENT VIA NYLON STUFFING TUBES

1. SCOPE

1.1 Scope. This method describes the procedures for BOF cable entry to fiber optic cable topology and other equipment through nylon stuffing tubes.

2. REQUIRED EQUIPMENT AND MATERIALS.

2.1 The equipment and materials in table 2G1-I shall be used to perform this procedure:

TABLE 2G1-I. Equipment and materials.

Description	Quantity
Safety glasses	1
Ruler	1
Deburring tool (or equivalent)	1
Paint scraper	1
Emery cloth	As required
Cable jacket stripping tool (NAVSEA DWG 6872811-08 or equal)	1
Kevlar shears (NAVSEA DWG 6872811-16 or equal)	1
Open end wrench (sized to fit locknut)	1
Spanner wrench (sized to fit cap)	1
Primer (type to suit metal)	As required
Talc (soap stone)	As required
RTV silicone rubber (Silastic 731731 or equal)	As required
Alcohol bottle with alcohol/2-propanol	1
Wipes	As required
Canned air (or compressed air)	As required

3. PROCEDURE.

3.1 Safety summary. The following safety precautions shall be observed:

- a. Observe warnings and cautions on equipment and materials.
- b. Never look into the end of a BOF tube. Always wear approved safety glasses when handling BOF tubes that may be connected to a pressure source.

3.2 Procedure.

NOTE: Packing assemblies and "O"-rings are not furnished with stuffing tubes. They must be ordered separately by the installing activity to suit installations.

Step 1 - Select the recommended stuffing tube, packing and "O"-ring in accordance with tables 2G1-II and 2G1-III.

MIL-STD-2042-2B(SH)

TABLE 2G1-II. Nylon stuffing tube sizes for BOF cable.

Type of Cable	Cable OD mm (in) nominal	Stuffing tube size	Packing assembly part no. ASTM F1836M/	Packing assembly opening mm (in)
Single-tube	11.125 (0.45)	3	18-018	12.0 (0.47)
7-tube	29.0 (1.14)	6	21-001	29.44 (1.16)
	31.5 (1.25)	6	21-004	31.6 (1.25)
19-tube	50.8 (2.00)	9	24-002	53.2 (2.09)

TABLE 2G1-III. Nylon stuffing tube data.

Stuffing tube sizes		Tube size 3	Tube size 6	Tube size 9
Straight tube	Tube part number ASTM F1836M/	1-003	1-007	1-010
	"O"-ring part number ASTM F1836M-	216	230	242
Angle tube	Tube part number ASTM F1836M/	2-003	NA	NA
	"O"-ring part number ASTM F1836M-	216	NA	NA
NPT Tube	Tube part number ASTM F1836M/	3-003	3-006	3-009
	NPT Tap mm (in)	25 (1.0)	50.8 (2.0)	88.9 (3.5)
"Y" Tube	Tube part number ASTM F1836M/	4-03	NA	NA
	"O"-ring part number ASTM F1836M-	216	NA	NA

NOTE: Angle and "Y" tubes are not defined for 7 and 19-tube BOF cables. These stuffing tubes are not compatible with the 7 and 19-tube BOF cables.

Step 2 - WARNING: Wear safety glasses during deburring to avoid possible eye injury.

Inspect the hole in the enclosure and remove any burrs or irregularities using the deburring tool.

Step 3 - For steel enclosures where the roughness is greater than a 125 microinch finish (not required on aluminum enclosures), remove the paint using a paint scraper and clean the surface with emery paper approximately 13 mm (0.5 inch) wide around the hole on the exterior of the enclosure. Apply one coat of primer, and allow to set. Dust coat the surface with talc if the primer is not thoroughly dried at the

MIL-STD-2042-2B(SH)

time of the stuffing tube installation. Remove the cover and proceed to step 4, 5 or 7 below, as applicable.

- Step 4 - With straight tubes, insert the stuffing tube body into the hole from the inside of the enclosure (see figure 2G1-1). If necessary, remove the interior fitting from enclosure. Proceed to step 6 below.

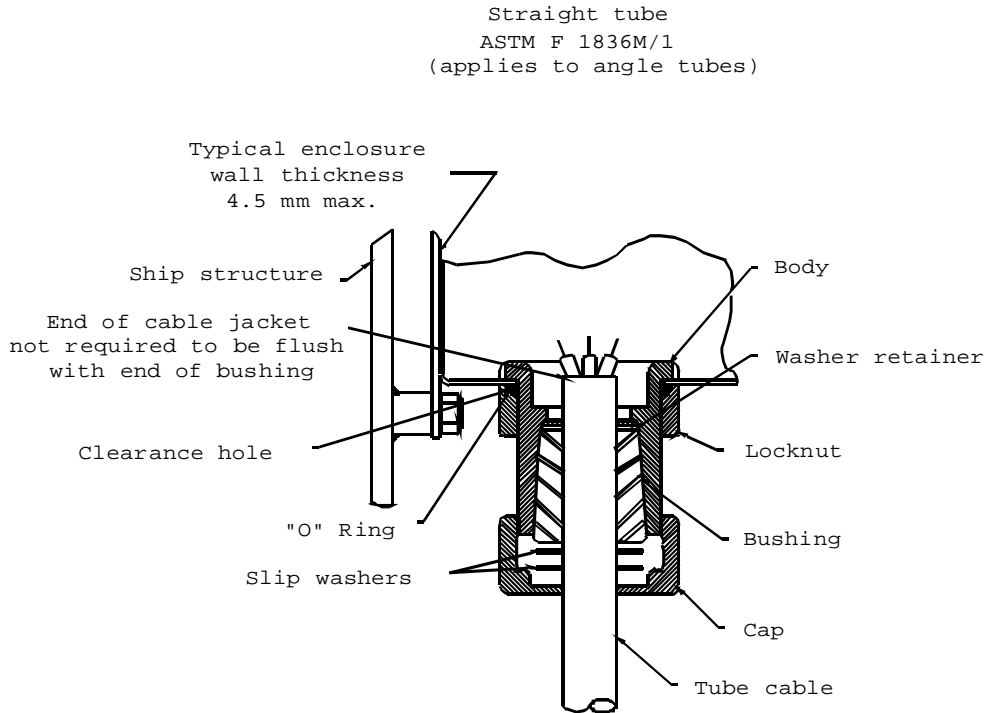

FIGURE 2G1-1. Straight tube.

- Step 5 - With "Y" and angle tubes, insert the stuffing tube body into the hole from the outside of enclosure (see figures 2G1-2 and 2G1-3). The excess length protruding into the enclosure may be removed.

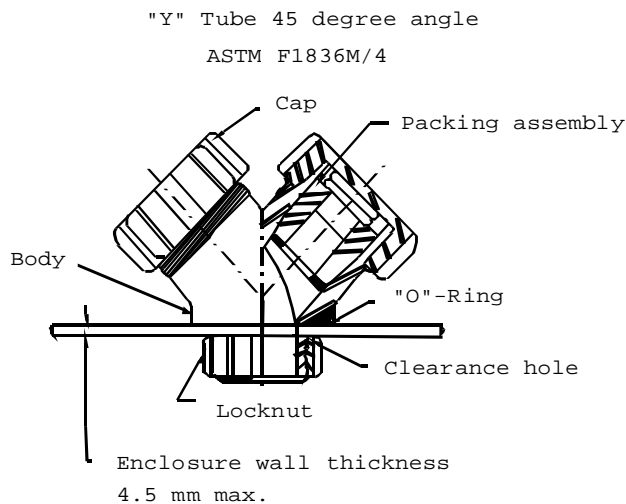
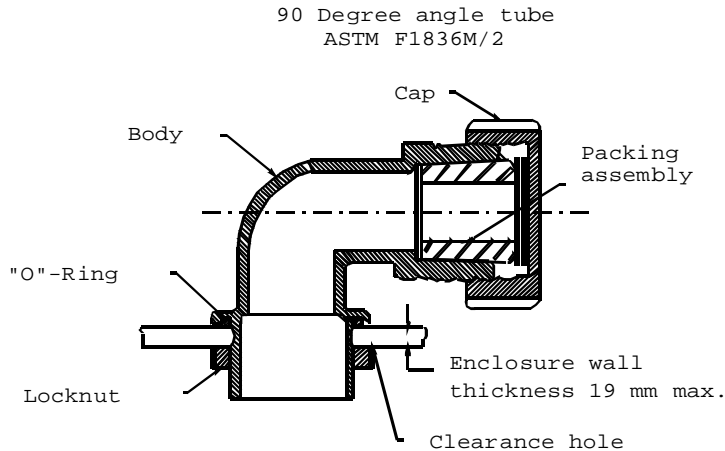

FIGURE 2G1-2. "Y" (45°) tube.

MIL-STD-2042-2B(SH)

FIGURE 2G1-3. 90° angle tube.

Step 6 - Screw the locknut onto the body and tighten with a wrench against the "O"-ring sufficiently to obtain plastic to metal contact of the stuffing tube and the enclosure. In cases where this plastic to metal contact cannot be obtained, tighten the locknut until the threads start to skip. This is considered a satisfactory indication of tightness. (Note: Hold the stuffing tube body while tightening the locknut to prevent turning.) Proceed to step 8 below.

Step 7 - With NPT tubes, screw the tube into the enclosure pipe thread and tighten it sufficiently to obtain a seal at the threads (see figure 2G1-4).

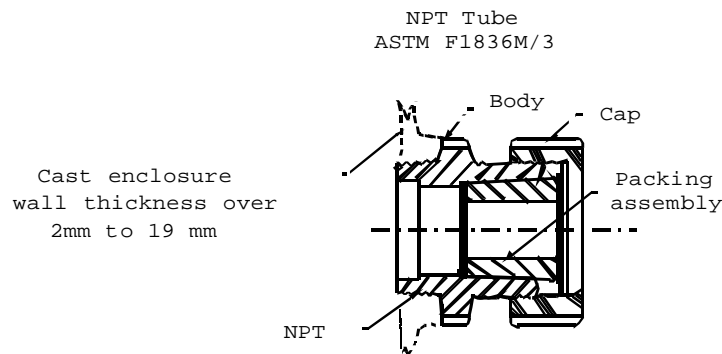
FIGURE 2G1-4. NPT tube.

Step 8 - Measure the distance required to route the BOF tubes from innermost portion of the stuffing tube to the most distant corner of the interconnection box (or to the furcation or end sealing region in the end user equipment). Add approximately 130 mm (5 in) to the distance and mark the BOF cable outer jacket.

Step 9 - Slide the stuffing tube parts onto the BOF cable in the order indicated:

- a. Cap
- b. Two slip washers

MIL-STD-2042-2B(SH)

c. Rubber bushing

d. Bottom washer

Step 10 -Slide the parts up the BOF cable beyond the mark and, if not already done, remove the outer jacket up to the mark using the cable stripper. Cut off the cable kevlar strength members and waterblocking materials, if present, using kevlar shears.

NOTE: If cable strength member capture is planned, leave approximately 100 mm (4 in) of the kevlar strength members protruding from the cable jacket.

If the required length of any of the BOF tubes is shorter than the exposed tube length, trim the tubes to the appropriate length.

NOTE: Make sure that the individual BOF tubes are not punctured, crushed, or kinked while trimming back the cable elements and the BOF tubes that will not be routed into the equipment.

Step 11 -Clean the BOF cable jacket and BOF tubes using a wipe dampened with alcohol. Blow dry with air.

Step 12 -End seal the BOF tubes that will not be routed into the equipment using Method 2J1-1 of this standard practice.

NOTE: This step may be performed after cable insertion into the stuffing tube if there is a problem inserting the BOF cable through the stuffing tube with the BOF tubes end sealed.

Step 13 -Insert the BOF cable through the stuffing tube and into the enclosure so that the outer jacket will protrude completely through the rubber bushing. Slide the washers and bushing down the cable into the stuffing tube. (NOTE: When necessary to pass an airtight test, apply RTV silicone rubber to the bushing.)

Step 14 -Slide the cap down the BOF cable, screw it onto the stuffing tube and tighten it sufficiently using the spanner wrench to compress the bushing to form a tight seal between the BOF cable and the stuffing tube. (NOTE: Hold the stuffing tube body when tightening the cap to prevent breaking the watertight seal.) After the bushing has been compressed for approximately 24 hours, retighten it to ensure the seal is maintained.

Step 15 -If required, wind the exposed kevlar strength member under a screw lug attached beside the stuffing tube and tighten the screw lug.

NOTE: This step is only performed when additional strain relief is required beyond that provided by the stuffing tube assembly.

Step 16 -If the BOF tubes will not be immediately formed and shaped within the equipment, close the equipment cover to keep dirt and moisture out of the BOF tubes.

MIL-STD-2042-2B(SH)

METHOD 2H1

BOF CABLE ENTRANCE TO EQUIPMENT VIA MCP

1. SCOPE.

1.1 Scope. This method describes a procedure for BOF cable entry to fiber optic cable topology and other equipment through multiple cable penetrations (MCP) integral to the equipment being entered.

2. REQUIRED EQUIPMENT AND MATERIALS.

2.1 The equipment and materials in table 2H1-I shall be used to perform this procedure.

TABLE 2H1-I. Equipment and materials.

Description	Quantity
Safety glasses	1
Ruler	1
Tallow (Hevi-Duty/Nelson AA0099 or equal)	As required
Open end wrench (sized to fit wedgepack nut)	1
Cable jacket stripping tool (NAVSEA DWG 6872811-08 or equal)	1
Kevlar shears (NAVSEA DWG 6872811-16 or equal)	1

3. PROCEDURE.

3.1 Safety Summary. The following safety precautions shall be observed:

- a. Observe warnings and cautions on equipment and materials.
- b. Never look into the end of a BOF tube. Always wear approved safety glasses when handling BOF tubes that may be connected to a pressure source.

3.2 Procedure.

Step 1 - Select MCP blocks in accordance with table 2H1-II.

MIL-STD-2042-2B(SH)

TABLE 2H1-II. MCP data and insert block sizes for BOF cables.

Cable type	Single-Tube	7-Tube	7-Tube	19-Tube
Cable OD mm (in) nominal	11.125 (0.44)	29.0 (1.14)	31.5 (1.25)	50.8 (2.00)
Primary insert block part number M24705/1-BN	2011	4029	4032	6050
Alternate insert block part number M24705/1-BN	NA	N/A	6032	6051
Blanking insert block part number M24705/1-BN	20	40	40	60
Alternate blanking insert block part number M24705/1- BN	NA	N/A	60	N/A

Step 2 - Measure the distance required to route the BOF tubes from the innermost portion of the MCP to the most distant corner of the interconnection box (or to the furcation or end sealing region in the end user equipment). Add approximately 130 mm (5 in) to the distance and mark the BOF cable outer jacket.

Step 3 - Remove the BOF cable outer jacket up to the mark using the cable jacket stripper. Cut off the cable kevlar strength members and waterblocking materials, if present, using the kevlar shears. If the required length of any of the BOF tubes is shorter than the exposed tube length, trim the tubes to the appropriate length.

NOTE: Make sure that the individual BOF tubes are not punctured, crushed, or kinked while trimming back the cable elements and the BOF tubes that will not be routed into the equipment.

Step 4 - End seal the BOF tubes that will not be routed into the equipment using Method 2J1-1 of this standard practice.

NOTE: This step may be performed after BOF cable insertion into the MCP if there is a problem inserting the BOF cable through the cable insert blocks with the BOF tubes end sealed.

Step 5 - Clean the BOF cable jacket and the BOF tubes using a wipe dampened with alcohol. Blow them dry with air.

Step 6 - **CAUTION:** Do not exceed the following BOF cable and BOF tube minimum bend diameters: BOF tube - 127 mm (5 in), 7-tube cable - 46 cm (18 in), and 19-tube cable - 1.27 m (50 in).

Feed the BOF cables into the interconnection box or the other equipment through the cable penetration opening.

Step 7 - Liberally apply tallow to the outside portion of the insert blocks, the inner portion of the MCP frame and to the sides of the wedgepack. Make sure that tallow is placed in the corners of the MCP frame. (NOTE: The wedgepack may be removed and disassembled to apply the tallow.)

MIL-STD-2042-2B(SH)

- Step 8 - Reinstall the wedgepack (if removed) and install the insert blocks on the BOF cables so that the outer jacket protrudes 13 mm (0.5 inch) to 25 mm (1 inch) inside the equipment. Install the cable insert blocks so that the gap between the insert block halves is parallel to the wedge pack. Install the insert blocks into the MCP frame so that the insert blocks are flush with the outside edge of the MCP frame. Fill all positions in the frame with insert blocks [either cable insert blocks or blanking (solid) insert blocks (see figure 2H1-1)]. (NOTE: Incoming BOF cables may be installed on one end of the enclosure and outgoing cables on the opposite end for large enclosures. Where only one penetrator is used, incoming cables may be installed on one side of the wedgepack and outgoing cables on the opposite side.)

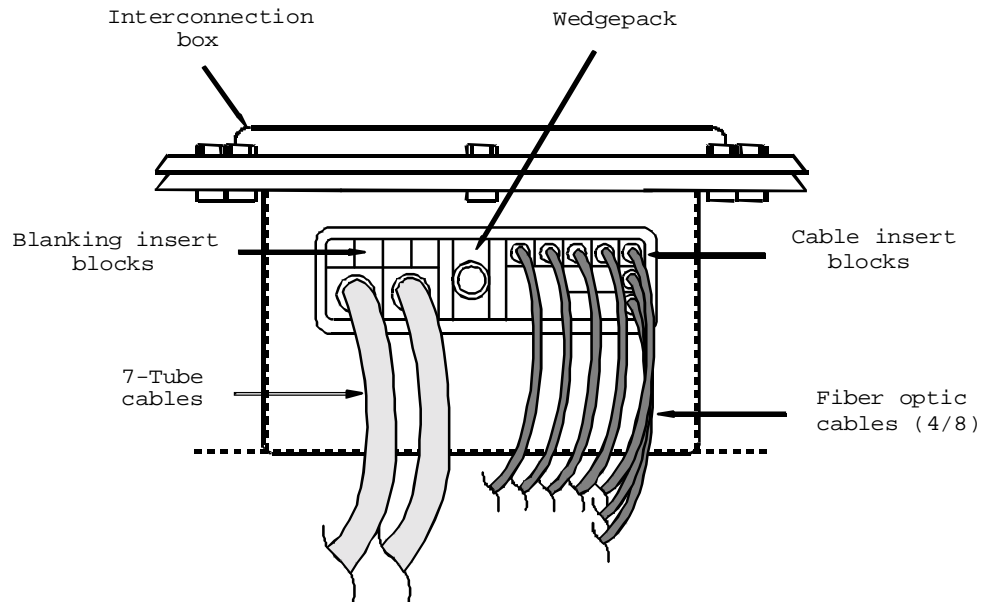

FIGURE 2H1-1. Interconnection box integral MCP (typical).

- NOTE: BOF cables generally should be installed near the ends of the MCP so that the BOF tubes can be easily routed to the sides of the equipment.
- Step 9 - Tighten the nut on the wedgepack to compress the insert blocks in the frame using a wrench. Tighten the wedgepack nut until the outside wedge pack metal plate is almost flush with the bottom of the MCP frame and the insert blocks. (NOTE: The wedge pack is fully tightened when the length of the pack is the same as the depth of the MCP frame.) Continue to tighten the wedgepack nut until a torque between 5.7 and 16.9 N-m (50 and 150 in-lbs) is reached. After the blocks have been compressed for approximately 24 hours, retighten the nut to ensure that the seal is maintained.
- Step 10 - If the BOF tubes will not be immediately formed and shaped within the equipment, close the equipment cover to keep dirt and moisture out of the BOF tubes.

MIL-STD-2042-2B(SH)

METHOD 2I1

BOF CABLE FORMING, ROUTING, AND SHAPING WITHIN TUBE ROUTING BOXES

1. SCOPE

1.1 Scope. This method describes the procedures for forming, routing and shaping BOF tubes within tube routing boxes.

2. REQUIRED EQUIPMENT AND MATERIALS.

2.1 The equipment and materials in the tables located in the applicable sections of this method shall be used to perform these procedures.

3. PROCEDURES

3.1 Safety summary. The following safety procedures shall be observed:

- a. Observe warnings and cautions on equipment and materials.
- b. Never look into the end of a BOF tube. Always wear approved safety glasses when handling BOF tubes that may be connected to a pressure source.

3.2 Procedure.

NOTE: To the maximum extent practicable, tube routing boxes should be sized to encourage BOF tube bend diameters greater than 460 mm (18 in). BOF tube bend diameters less than 460 mm (18 in) will negatively impact the blowing distances achievable for 12 and 18-fiber BOF bundles.

NOTE: When the number of tubes in a tube routing box is large to make strict compliance with this procedure impractical, this procedure shall be used as guidance.

3.3 The equipment and materials in table 2I1-I shall be used to perform this procedure.

TABLE 2I1-I. Equipment and materials.

Description	Quantity
BOF tubing (8 mm x 6 mm)	As required
Straight tube coupler (AA59731-U-8 or AA59731-U-8E)	As required
Tee tube coupler (AA59731-T-8 or AA59731-T-8E)	As required
Tube cutter	1
Ruler	1
Utility knife	1
Heat shrink tubing (SAE-DTL-23053/5 or equal)	As required
Heat gun (Raychem 500B or equal)	1
Tube clip (Sumitomo DETC008 or equal) or small plastic or metal bar	As required
Self-clinching straps (SAE AS 23190 or equal)	As required
Pressure valve assembly (Connective Solutions FC08B1 or equal)	1

MIL-STD-2042-2B(SH)

- NOTE: Keep BOF tube couplers and the ends of BOF tubes clean and free of contaminants.
- NOTE: BOF tube couplers may be cleaned using distilled water and blown dry with air. Do not clean or soak BOF tube couplers in alcohol or other cleaning agents. BOF tube couplers can be permanently damaged by exposure to alcohol and cleaning agents.
- NOTE: Previously used BOF tube couplers may not adequately seal to BOF tubes. When installing BOF cabling, always use new BOF tube couplers.
- CAUTION: Do not disengage mated BOF tube couplers. Disengaging utilized BOF tube couplers may damage/break the optical fibers contained within the BOF tubes.

- Step 1 - Verify that the procedures of Method 2G1 or Method 2H1 of this standard practice have been completed for all BOF cables entering the tube routing box.
- Step 2 - Open the tube routing box cover and visually examine the BOF tubes for cuts or kinks before continuing.
- Step 3 - CAUTION: Do not exceed a bend diameter of 13 cm (5 in) for the BOF tubes. BOF tubes may collapse at diameters less than 13 cm (5 in).

Choose a BOF cable and route BOF tube number one to the nearest side of the box. Route the BOF tube along the side and mark the tube 100 to 150 mm (4 to 6 in) from the far corner of the box. Successively route and mark each BOF tube within the BOF cable (staggering each tube approximately 44 mm (1.7 in) shorter than the previous tube is recommended). Using the tube cutter, cut each tube at the mark. Visually verify that the end of the tube is cut perpendicular to the tube length. Clean the end of each BOF tube with a wipe dampened with alcohol and blow dry as necessary.

- NOTE: Small BOF tube bend diameters may not allow 12 and 18-fiber BOF bundles to be blown through the tube routing box. Maximize BOF tube bend diameters to the maximum extent practicable.
- NOTE: BOF tube bend diameters less than 18 in will negatively impact the blowing distances achievable for 12 and 18-fiber BOF bundles.
- Step 4 - CAUTION: Do not overheat the BOF tubes. Prolonged exposure of the BOF tubes to temperatures above 160°C (320°F) may damage them. Discontinue heating of the sleeve and allow the BOF tubes to cool before reheating if the tubes show any signs of bubbling or swelling.
- Slide the heat shrink tubing with the tube identification onto each BOF tube of the BOF cable approximately 100 mm (4 in) from the tube end. Holding the heat gun approximately 100 mm (4 in) away from each BOF tube, shrink the shrink tubing.
- Step 5 - Form the BOF tubes into a flat group and route the group along the side of the box as follows (see figure 2I1-1):

MIL-STD-2042-2B(SH)

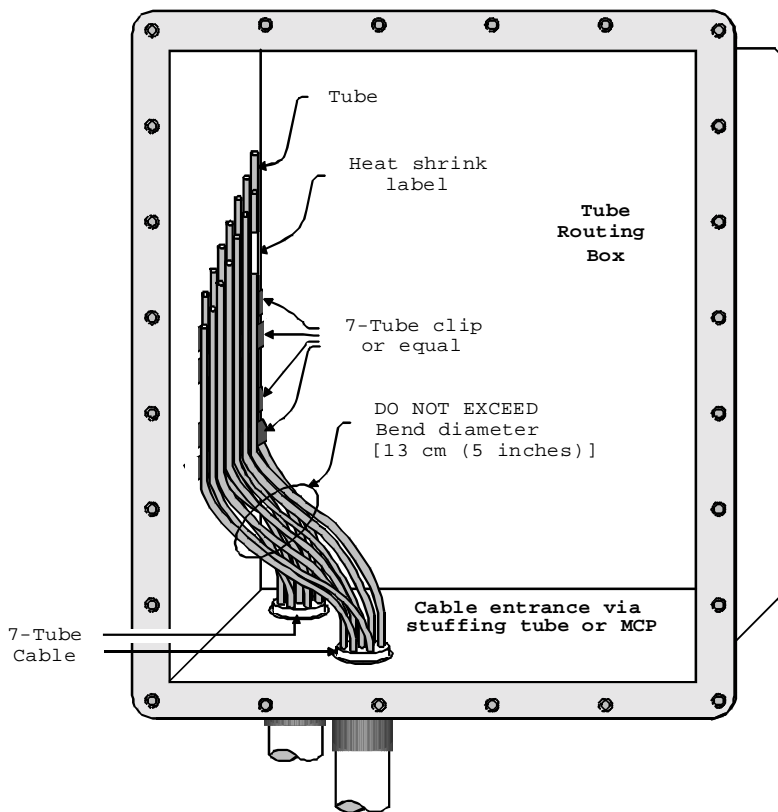

FIGURE 2I1-1. Routing BOF tubes in TRB.

- a. Snap the BOF tubes into a 7-tube clip or lace the tubes flat to a small plastic or metal bar. Place the longest BOF tube to the rear of the box with each successively shorter tube placed to the front of the previous tube (if the BOF tube lengths are staggered).
- b. Route the group of BOF tubes along the side of the box securing the group to the box mounting brackets (if available) using self-clinching straps.

Step 6 - Repeat steps 3, 4 and 5 for each BOF cable entering the tube routing box.

NOTE: The tubes of each successive BOF cable should be shortened approximately 50 mm (2 in) compared to the previous BOF cable routed on the same side of the box.

NOTE: Spacers may be used to separate tube groups to facilitate access.

Step 7 - Observe the tube connection chart or other approved drawing. Identify BOF tubes that will not be connected and end seal them in accordance with Method 2J1 of this standard.

Step 8 - Slide a straight tube coupler or a tee tube coupler onto the tube and firmly seat the tube coupler on the tube.

MIL-STD-2042-2B(SH)

- NOTE: Before assembling the tube coupler onto the tube, clean the end of each BOF tube with a wipe dampened with alcohol and blow dry as necessary.
- NOTE: Refer to the connection chart or other approved drawing to determine where to use straight tube couplers and where to use tee tube couplers.
- NOTE: When a tee tube coupler is used, the tee connection is end sealed in accordance with Method 2J1 of this standard after conduct of the tube sealing integrity test.

Step 9 - For all locations where a tee tube coupler is used, one of the following optional steps may be performed:

- option a. Using the tube cutter, cut a short piece of BOF tubing (length as necessary to allow easy access). Visually verify that the ends of the tube are cut perpendicular to the tube length. Clean the ends of the BOF tube with a wipe dampened with alcohol and blow dry as necessary. Slide the short tube into the tee position of the tee tube coupler. Firmly seat the short BOF tube into the tee tube coupler. Apply an axial load of approximately 22 N (5 lbs) between the BOF tube and the tee tube coupler to verify that it is properly engaged into the tube coupler.
- option b. Clean the pressure valve assembly with a wipe dampened with alcohol and blow dry as necessary. Slide the pressure valve assembly into the tee position of the tee tube coupler. Firmly seat the pressure valve assembly into the tee tube coupler. Apply an axial load of approximately 22 N (5 lbs) between the pressure valve assembly and the tee tube coupler to verify that it is properly engaged into the tube coupler.
- option c. Clean a tube fitting plug with a wipe dampened with alcohol and blow dry as necessary. Slide the tube fitting plug into the tee position of the tee tube coupler. Apply an axial load of approximately 22 N (5 lbs) between the tube fitting plug and the tee tube coupler to verify that it is properly engaged into the tube coupler.

Step 10 - Identify two BOF tubes to be interconnected, plan the path of the interconnecting jumper tube (see figure 2I1-2), and determine the length of the required jumper tube. Using the tube cutter, cut a piece of BOF tubing to the required length. Visually verify that the end of the tube is cut perpendicular to the tube length. Clean each end of the BOF tube with a wipe dampened with alcohol and blow dry as necessary.

NOTE: The path of the jumper tube should follow the exterior of the tube routing box to the greatest extent possible.

NOTE: When the two tubes to be interconnected are located on the same side of the tube routing box, a figure-eight type of path should be used (see figure 2I1-2).

Step 11 - **CAUTION:** Do not exceed a bend diameter of 13 cm (5 in) for the BOF tubes. BOF tubes may collapse at diameters less than 13 cm (5 in).

Form the jumper tube along the planned path. Slide the jumper tube into the tube coupler of each of the two BOF tubes to be interconnected. Firmly seat the jumper tube into each tube coupler. Apply an axial load of approximately 22 N (5 lbs) between the BOF tubes and the jumper tube to verify that they are properly engaged into the tube couplers. Secure the jumper tube to the box mounting brackets (if available) using self-clinching straps.

MIL-STD-2042-2B(SH)

- NOTE: Small BOF tube bend diameters may not allow 12 and 18-fiber BOF bundles to be blown through the tube routing box. Maximize BOF tube bend diameters to the greatest extent practicable.
- NOTE: BOF tube bend diameters less than 18 in will negatively impact the blowing distances achievable for 12 and 18-fiber BOF bundles.
- NOTE: BOF tube loops with a diameter larger than the tube routing box may be utilized during fiber installation to improve blowing performance. During the blowing operation, the BOF tubes may be extended outside of the tube routing box. After the blowing operation, the large loop can be collapsed into multiple smaller loops for stowage within the tube routing box. An additional tube coupler may be placed in the middle of the large loop to facilitate collapse of the large loop into multiple smaller loops.
- Step 12 -Repeat steps 10 and 11 until all required tube interconnections have been accomplished.
- Step 13 -Close and secure the tube routing box cover.

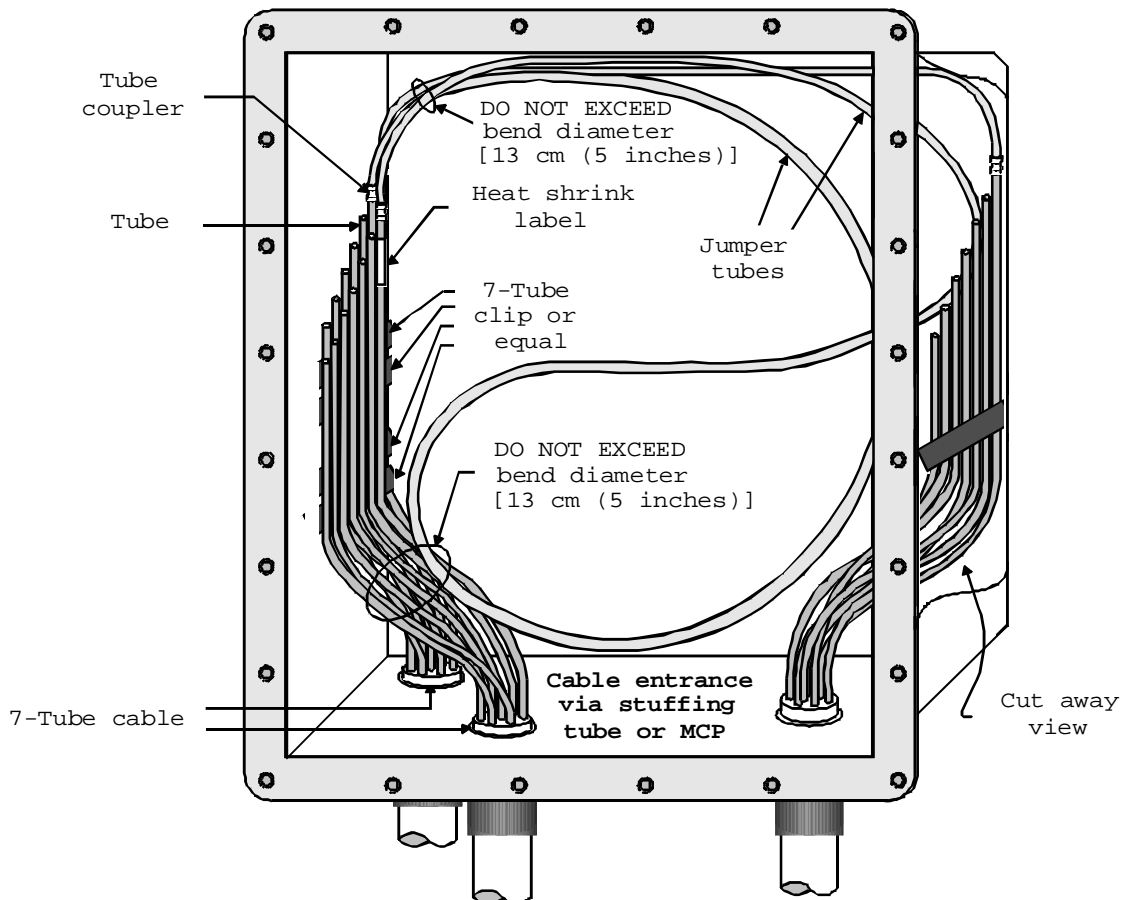
FIGURE 2I1-2. Typical jumper tube paths.

MIL-STD-2042-2B(SH)

METHOD 2I2

BOF CABLE FORMING, ROUTING, AND SHAPING WITHIN INTERCONNECTION BOXES

1. SCOPE

1.1 Scope. This method describes the procedures for forming, routing and shaping BOF tubes within interconnection boxes or other equipment.

2. REQUIRED EQUIPMENT AND MATERIALS.

2.1 The equipment and materials in the tables located in the applicable sections of this method shall be used to perform these procedures.

3. PROCEDURES

3.1 Safety summary. The following safety procedures shall be observed:

- a. Observe warnings and cautions on equipment and materials.
- b. Never look into the end of a BOF tube. Always wear approved safety glasses when handling BOF tubes that may be connected to a pressure source.

3.2 Procedure.

3.2.1 The equipment and materials in table 2I2-I shall be used to perform this procedure.

TABLE 2I2-I. Equipment and materials.

Description	Quantity
Tube coupler (AA59731-U-8 or AA59731-U-8E)	As required
Tube cutter	1
Ruler	1
Utility knife	1
Heat shrink tubing (MIL-T-23053/5 or equal)	As required
Heat gun (Raychem 500B or equal)	1
Tube clip (Sumitomo DETC008 or equal) or small plastic or metal bar	As required
Self-clinching straps (SAE AS 23190 or equal)	As required
Open end wrench	1

NOTE: Keep BOF tube couplers and the ends of BOF tubes clean and free of contaminants.

NOTE: BOF tube couplers may be cleaned using distilled water and blown dry with air. Do not clean or soak BOF tube couplers in alcohol or other cleaning agents. BOF tube couplers can be permanently damaged by exposure to alcohol and cleaning agents.

NOTE: Previously used BOF tube couplers may not adequately seal to BOF tubes. When installing BOF cabling, always use new BOF tube couplers.

CAUTION: Do not disengage mated BOF tube couplers unless authorized. Disengaging utilized BOF tube couplers may damage/break the optical fibers contained within the BOF tubes.

MIL-STD-2042-2B(SH)

Step 1 - Verify that the procedures of Method 2G1 or Method 2H1 of this standard practice have been completed for all BOF cables entering the interconnection box.

Step 2 - Open the equipment cover and visually examine the BOF tubes for cuts or kinks before continuing.

Step 3 - CAUTION: Do not exceed a bend diameter of 13 cm (5 in) for the BOF tubes. BOF tubes may collapse at diameters less than 13 cm (5 in).

Choose a BOF cable and route BOF tube number one to the nearest side of the box. Route the BOF tube along the side and mark the tube approximately 200 mm (8 in) from the far corner of the box. Successively route and mark each BOF tube within the BOF cable (staggering each tube approximately 44 mm (1.7 in) shorter than the previous tube is recommended). Using the tube cutter, cut each tube at the mark. Visually verify that the end of the tube is cut perpendicular to the tube length. Clean the end of each BOF tube with a wipe dampened with alcohol and blow dry as necessary.

NOTE: Small BOF tube bend diameters may not allow 12 and 18-fiber BOF bundles to be blown through the tube bend. Maximize BOF tube bend diameters to the greatest extent practicable.

NOTE: BOF tube bend diameters less than 18 in will negatively impact the blowing distances achievable for 12 and 18-fiber BOF bundles.

NOTE: BOF tubes may be extended outside of the interconnection box (to enlarge the tube bend diameter) during fiber installation to improve blowing performance.

Step 4 - CAUTION: Do not overheat the BOF tubes. Prolonged exposure of the BOF tubes to temperatures above 160°C (320°F) may damage them. Discontinue heating of the sleeve and allow the BOF tubes to cool before reheating if the tubes show any signs of bubbling or swelling.

Slide the heat shrink tubing with the tube identification onto each BOF tube of the BOF cable approximately 100 mm (4 in) from the tube end. Holding the heat gun approximately 100 mm (4 in) away from each BOF tube, shrink the shrink tubing.

Step 5 - Form the BOF tubes into a flat group and route the group along the side of the box as follows (see figure 2I2-1):

- a. Snap the BOF tubes into a 7-tube clip or lace the tubes flat to a small plastic or metal bar. Place the longest BOF tube to the rear of the box with each successively shorter tube placed to the front of the previous tube (if the BOF tube lengths are staggered).
- b. Route the group of BOF tubes along the side of the box securing the group to the box mounting brackets using self-clinching straps.

Step 6 - Repeat steps 3, 4 and 5 for each BOF cable entering the interconnection box.

NOTE: The tubes of each successive BOF cable should be shortened approximately 50 mm (2 in) compared to the previous BOF cable routed on the same side of the box.

NOTE: Spacers may be used to separate tube groups to facilitate access.

Step 7 - Observe the connection chart or other approved drawing. Identify BOF tubes that will not have fibers installed and end seal them in accordance with Method 2J1 of this standard.

MIL-STD-2042-2B(SH)

- Step 8 - Identify those BOF tubes that are to have fibers installed and install fibers into them in accordance with the manufacturer's instructions.
- Step 9 - For each BOF tube containing fibers, install a tube furcation unit onto the tube in accordance with Method 2F1 of this standard and terminate the furcation cables in accordance with part 5 of this standard.
- Step 10 - Form and shape the optical fiber cables and furcation unit's loose tube furcation cables within the interconnection box in accordance with Method 2C1 of this standard.
- Step 11 - For each BOF tube containing fibers, verify the integrity of the end seals in accordance with Method 6J1 of this standard.

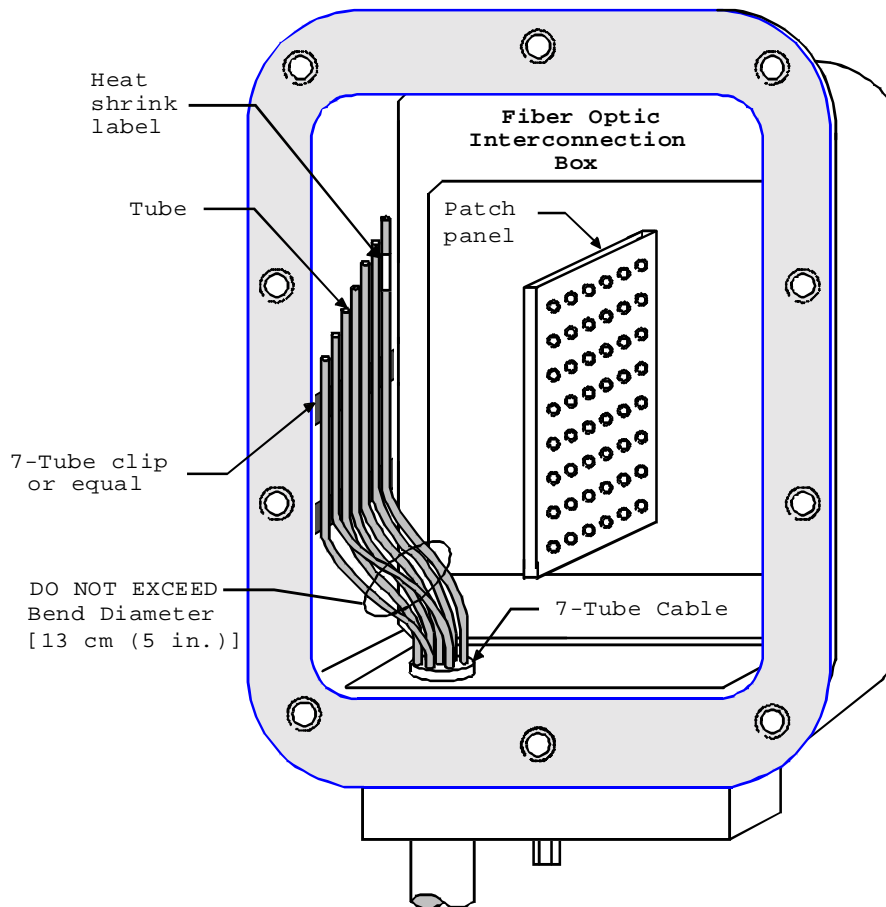
FIGURE 2I2-1. Routing BOF tubes in a FOICB.

MIL-STD-2042-2B(SH)

METHOD 2J1

BOF TUBE END SEALING

1. SCOPE

1.1 Scope. This method describes the procedures for sealing the ends of empty BOF tubes in tube routing boxes, fiber optic interconnection boxes and equipment.

2. REQUIRED EQUIPMENT AND MATERIALS.

2.1 The equipment and materials in the tables located in the applicable sections of this method shall be used to perform these procedures.

3. PROCEDURES

3.1 Safety summary. The following safety procedures shall be observed:

- a. Observe warnings and cautions on equipment and materials.
- b. Never look into the end of a BOF tube. Always wear approved safety glasses when handling BOF tubes that may be connected to a pressure source.

3.2 Procedure.

3.3 The equipment and materials in table 2J1-I shall be used to perform this procedure.

TABLE 2J1-I. Equipment and materials.

Description	Quantity
Safety glasses	1
Tube coupler (AA59731-U-8 or AA59731-U-8E)	As required
Tube coupler plug (AA59728-TFP-8)	As required
Tube end cap (AA59731-EC-8)	As required
Wipes	As required

NOTE: Keep BOF tube couplers and the ends of BOF tubes clean and free of contaminants.

NOTE: BOF tube couplers may be cleaned using distilled water and blown dry with air. Do not clean or soak BOF tube couplers in alcohol or other cleaning agents. BOF tube couplers can be permanently damaged by exposure to alcohol and cleaning agents.

NOTE: Previously used BOF tube couplers may not adequately seal to BOF tubes. When installing BOF cabling, always use new BOF tube couplers.

Step 1 - Verify that the procedures of Method 2I1-1 or Method 2I1-2 of this standard practice have been completed.

Step 2 - Determine if the other end of the BOF tube has been end sealed in accordance with this method. If the other end of the BOF tube has been end sealed, verify the integrity of the end seal in accordance with Method 6J1 of this standard.

MIL-STD-2042-2B(SH)

Step 3 - Perform one of the following steps:

- a. Clean the end of the BOF tube with a wipe dampened with alcohol and blow dry as necessary. Slide a tube coupler onto the BOF tube and firmly seat it. Clean the tube coupler plug with a wipe dampened with alcohol and blow dry as necessary. Insert the tube coupler plug in the other end of the tube coupler and firmly seat it within the tube coupler. Apply an axial load of approximately 22 N (5 lbs) between the BOF tube and the tube coupler plug to verify that they are properly engaged into the tube coupler.
- b. Clean the end of the BOF tube with a wipe dampened with alcohol and blow dry as necessary. Slide a tube end cap onto the BOF tube and firmly seat it. Apply an axial load of approximately 22 N (5 lbs) between the BOF tube and the tube end cap to verify that the BOF tube is properly engaged into the tube end cap.

STANDARDIZATION DOCUMENT IMPROVEMENT PROPOSAL**INSTRUCTIONS**

1. The preparing activity must complete blocks 1, 2, 3, and 8. In block 1, both the document number and revision letter should be given.
2. The submitter of this form must complete blocks 4, 5, 6, and 7.
3. The preparing activity must provide a reply within 30 days from receipt of the form.

NOTE: This form may not be used to request copies of documents, nor to request waivers, or clarification of requirements on current contracts. Comments submitted on this form do not constitute or imply authorization to waive any portion of the referenced document(s) or to amend contractual requirements.

I RECOMMEND A CHANGE:

1. DOCUMENT NUMBER
MIL-STD-2042-2

2. DOCUMENT DATE (YYMMDD)

3. DOCUMENT TITLE

FIBER OPTIC CABLE TOPOLOGY INSTALLATION STANDARD METHODS FOR NAVAL SHIPS (EQUIPMENT)

4. NATURE OF CHANGE (Identify paragraph number and include proposed rewrite, if possible. Attach extra sheets as needed.)

5. REASON FOR RECOMMENDATION**6. SUBMITTER**

a. NAME (Last, First, Middle initial)

b. ORGANIZATION

c. ADDRESS (Include Zip Code)

d. TELEPHONE (Include Area Code)

7. DATE SUBMITTED
(YYMMDD)

(1) Commercial
(2) AUTOVON
(If applicable)

8. PREPARING ACTIVITY

a. NAME
Ruth Butler

b. TELEPHONE (Include Area Code)
(1) Commercial (2) AUTOVON
(202) 781-3726 326-3726

c. ADDRESS (Include Zip Code)
Commander, Naval Sea Systems Command
ATTN: SEA 05Q
1333 Isaac Hull Avenue Southeast, Stop 5160
Washington Navy Yard, DC 20376-5160

IF YOU DO NOT RECEIVE A REPLY WITHIN 45 DAYS, CONTACT:
Defense Standardization Program Office (DLSC-LM)
8725 John J. Kingman Road, Suite 2533
Fort Belvoir, Virginia 22060-6221
Telephone (703) 767-6888 DSN 427-6888