

METRIC

MIL-STD-2042-2A(SH)
29 September 1997
SUPERSEDING
MIL-STD-2042-2(SH)
7 July 1993

DEPARTMENT OF DEFENSE
STANDARD PRACTICE
FIBER OPTIC CABLE TOPOLOGY INSTALLATION
STANDARD METHODS FOR NAVAL SHIPS
(EQUIPMENT)
(PART 2 OF 6 PARTS)



MIL-STD-2042-2A(SH)

FOREWORD

1. This Department of Defense Standard Practice is approved for use by the Naval Sea Systems Command, Department of the Navy, and is available for use by all Departments and Agencies of the Department of Defense.

2. Beneficial comments (recommendations, additions, deletions) and any pertinent data which may be of use in improving this document should be addressed to: Commander, Naval Sea Systems Command, SEA 03K12, 2531 Jefferson Davis Highway, Arlington, VA 22242-5160 by using the self-addressed Standardization Document Improvement Proposal (DD Form 1426) appearing at the end of this document or by letter.

3. This standard practice provides detailed information and guidance to personnel concerned with the installation of fiber optic cable topologies (fiber optic cabling and associated components) on Naval surface ships and submarines. The methods specified herein are not identifiable to any specific ship class or type, but are intended to standardize and minimize variations in installations to enhance the compatibility of the installations on all Naval ships.

4. In order to provide flexibility in the use and update of the installation methods, this standard practice is issued in seven parts; the basic standard practice and six numbered parts as follows:

- Part 1 Cables
- Part 2 Equipment
- Part 3 Cable Penetrations
- Part 4 Cableways
- Part 5 Connectors and Interconnections
- Part 6 Tests

MIL-STD-2042-2A(SH)

CONTENTS

<u>PARAGRAPH</u>		<u>PAGE</u>
1.	SCOPE	1
1.1	Scope	1
1.1.1	Applicability	1
2.	APPLICABLE DOCUMENTS	2
2.1	General	2
2.2	Government documents	2
2.2.1	Specifications, standards and handbooks	2
2.2.2	Other government documents	3
2.3	Non-Government publications	3
2.4	Order of precedence	3
3.	DEFINITIONS	4
3.1	General fiber optics terms	4
3.2	Allocated and not used fiber	4
3.3	Allocated and used fiber	4
3.4	Alternate channel	4
3.5	Authorized approval	4
3.6	End user equipment	4
3.7	Fiber optic cable topology	4
3.8	Installing activity	4
3.9	Local cable	4
3.10	Minimum bend diameter	4
3.11	Multicable penetrator (MCP)	4
3.12	Non-redundant channel (NRC)	4
3.13	Normal channel	4
3.14	Optical fiber cable component (OFCC)	4
3.15	Outlet	4
3.16	Spare fibers	4
3.17	Trunk cable	4
3.18	Unused fiber	4
4.	GENERAL REQUIREMENTS	5
4.1	Fiber optic equipment installation	5
4.1.1	Interconnection box selection	5
4.1.2	Location	5
4.1.3	Interconnection box mounting	5
4.1.3.1	Bonding, grounding, and shielding	5
4.1.3.2	Holes drilled in beams	5
4.1.3.3	Welding	5
4.1.3.4	Fasteners	5
4.1.3.5	Dissimilar metals	5
4.2	Cable entrance to equipment	6
4.2.1	Cable slack	6
4.2.2	Cable forming and shaping	6
4.2.3	Splice assembly and alignment	6
4.2.4	Interconnection organization	6
4.2.4.1	Connector organization	6
4.2.4.2	Splice organization	7
4.2.5	Nameplates and marking	7
4.3	Safety precautions	8
5.	DETAILED REQUIREMENTS	9
5.1	Fiber optic interconnection equipment installation	9
5.1.1	Non-watertight decks and bulkheads	9
5.1.2	Watertight decks and bulkheads	9
5.1.3	Stanchions	9
5.1.4	Metal joiner bulkheads	9
5.1.5	Expanded metal or wire mesh bulkhead	9
5.1.6	Refrigerated spaces	9
5.1.7	GRP (glass reinforced plastic) bulkheads	9
5.1.8	Locking devices for installations on submarines	9
5.2	Cable entrance to equipment	9
5.2.1	Nylon stuffing tubes	9
5.2.2	Multiple cable penetrator (MCP)	9
5.2.3	Cable clamps	9
5.3	Interconnection organization	10
5.4	Splice assembly and alignment	10
6.	NOTES	11
6.1	Intended use	11
6.2	Issue of DODISS	11
6.3	Standard method designation	11

MIL-STD-2042-2A(SH)

CONTENTS

<u>PARAGRAPH</u>		<u>PAGE</u>
6.4	Subject term (key word) listing	11
 <u>METHOD</u>		
2A1	Cable entrance to equipment via nylon stuffing tubes	2A1-1
2B1	Cable entrance to equipment via MCP	2B1-1
2C1	Cable and buffered fiber forming and shaping	2C1-1
2D1	Splice assembly and alignment	2D1-1
 <u>TABLE</u>		
2A1-I	Equipment and materials.	2A1-1
2A1-II	Nylon stuffing tube sizes for fiber optic cable.	2A1-2
2A1-III	Nylon stuffing tube data	2A1-2
2B1-I	Equipment and materials.	2B1-1
2B1-II	MCP data and insert block sizes for fiber optic cables	2B1-2
2C1-I	Equipment and materials	2C1-1
2D1-I	Equipment and materials.	2D1-1
 <u>FIGURE</u>		
2-1	Configuration of patch panel - (typical)	6
2-2	Configuration of splice module -(typical)	7
2-3	Configurations of splice tray - (typical)	7
2A1-1	Straight tube	2A1-3
2A1-2	"Y" (45°) tube	2A1-3
2A1-3	90° angle tube	2A1-4
2A1-4	NPT tube	2A1-4
2B1-1	Interconnection box integral MCP-(typical)	2B1-2
2C1-1	Forming and shaping - (typical)	2C1-2
2C1-2	Compressing ferrule springs	2C1-4
2C1-3	Splices installed in splice tray - (typical)	2C1-4
2D1-1	Opening alignment sleeve	2D1-2
2D1-2	Inserting ferrule into alignment sleeve	2D1-2
2D1-3	Inserting second ferrule into alignment sleeve	2D1-2
2D1-4	Aligning tabs	2D1-3
2D1-5	Power Meter Cable hookup- (typical)	2D1-3

MIL-STD-2042-2A(SH)

1. SCOPE

1.1 Scope. This standard provides detailed methods for the installation of fiber optic cable topology equipment (see 3.7), and fiber optic cable entry to fiber optic cable topology and other equipment.

1.1.1 Applicability. These criteria apply to installations on specific ships when invoked by the governing ship specification or other contractual document. They are intended primarily for new construction; however, they are also applicable for conversion or alteration of existing ships. The rapidly changing state of the art in fiber optic technology makes it essential that some degree of flexibility be exercised in enforcing this document. When there is a conflict between this document and the ship specification or contract, the ship specification or contract shall take precedence. Where ship design is such that the methods herein cannot be implemented, users shall submit new methods or modifications of existing methods to NAVSEA 03K12 for approval prior to implementation.

MIL-STD-2042-2A(SH)

2. APPLICABLE DOCUMENTS

2.1 General. The documents listed in this section are specified in sections 3, 4 and 5 of this standard. This section does not include documents cited in other sections of this standard or recommended for additional information or as examples. While every effort has been made to ensure the completeness of this list, document users are cautioned that they must meet all specified requirements documents cited in sections 3, 4 and 5 of this standard, whether or not they are listed.

2.2 Government documents.

2.2.1 Specifications, standards and handbooks. The following specifications, standards, and handbooks form a part of this document to the extent specified herein. Unless otherwise specified, the issues of these documents are those listed in the issue of the Department of Defense Index of Specifications and Standards (DODISS) and supplement thereto, cited in the solicitation (see 6.2).

DEPARTMENT OF DEFENSE SPECIFICATIONS

- MIL-P-15024 - Plates, Tags and Bands for Identification of Equipment.
- MIL-P-15024/5 - Plates, Identification.
- MIL-S-19622 - Stuffing Tubes, Nylon; and Packing Assemblies, General Specification for.
- MIL-T-23053 - Insulation Sleeving, Electrical, Heat Shrinkable, General Specification for.
- MIL-T-23053/5 - Insulation Sleeving, Electrical, Heat Shrinkable, Polyolefin, Flexible, Crosslinked.
- MIL-S-23190 - Straps, Clamps and Mounting Hardware, Plastic and Metal for Cable Harness Tying and Support.
- MIL-S-24235 - Stuffing Tubes, Metal and Packing Assemblies for Electric Cables, General Specification for.
- MIL-S-24623 - Splice, Fiber Optic Cable, General Specification for (Metric).
- MIL-S-24623/4 - Splice, Fiber Optic, Housing, Fiber.
- MIL-I-24728 - Interconnection Box, Fiber Optic, Metric, General Specification for.

DEPARTMENT OF DEFENSE STANDARDS

- MIL-STD-278 - Welding and Casting Standard.
- MIL-STD-461 - Electromagnetic Emission and Susceptibility Requirements for the Control of Electromagnetic Interference.
- MIL-STD-889 - Dissimilar Metals.
- MIL-STD-1310 - Shipboard Bonding, Grounding, and other Techniques for Electromagnetic Compatibility and Safety.
- MIL-STD-2003 - Electric Plant Installation Standard Methods for Surface Ships and Submarines.
- MIL-STD-2003-1 - Electric Plant Installation Standard Methods for Surface Ships and Submarines (Cable).
- MIL-STD-2003-2 - Electric Plant Installation Standard Methods for Surface Ships and Submarines (Equipment).
- MIL-STD-2042-1 - Fiber Optic Topology Installation Standard Methods for Naval Ships (Cables)(Part 1 of 6 Parts).
- MIL-STD-2042-5 - Fiber Optic Topology Installation Standard Methods for Naval Ships (Connections and Interconnections)(Part 5 of 6 Parts).
- MIL-STD-2042-6 - Fiber Optic Topology Installation Standard Methods for Naval Ships (Tests)(Part 6 of 6 Parts).

MIL-STD-2042-2A(SH)

(Unless otherwise indicated, copies of the above specifications, standards, and handbooks are available from the Standardization Documents Order Desk, 700 Robbins Ave, Building 4D, Philadelphia, PA, 19111-5094.)

2.2.2 Other Government documents. The following other Government documents form a part of this document to the extent specified herein. Unless otherwise specified, the issues are those cited in the solicitation.

DEPARTMENT OF DEFENSE DRAWINGS

NAVSEA Drawing - 6872812 Tool Kit, MIL-S-24623, Fiber Optic, Navy Shipboard.

(Copies of documents should be obtained from the contracting activity or as directed by the contracting officer.)

2.3 Non-Government publications. The following documents form a part of this document to the extent specified herein. Unless otherwise specified, the issues of the documents which are DOD adopted are those listed in the issue of the DODISS cited in the solicitation. Unless otherwise specified, the issues of documents not listed in the DODISS are the issues of the documents cited in the solicitation (see 6.2).

AMERICAN NATIONAL STANDARDS INSTITUTE (ANSI)

ANSI Z136.2 - Safe Use of Optical Fiber Communication Systems Utilizing Laser Diode and LED Sources

(Application for copies should be addressed to the American National Standards Institute, 1430 Broadway, New York, NY 10018-3308.)

ELECTRONICS INDUSTRY ASSOCIATION/TELECOMMUNICATIONS INDUSTRY ASSOCIATION

EIA/TIA-440 - Fiber Optic Terminology.

(Application for copies should be addressed to Global Engineering Documents, 1990 M Street NW, Suite 400, Washington, DC 20036.)

2.4 Order of precedence. In the event of a conflict between the text of this document and the references cited herein, the text of this document takes precedence. Nothing in this document, however, supersedes applicable laws and regulations unless a specific exemption has been obtained.

MIL-STD-2042-2A(SH)

3. DEFINITIONS

3.1 General fiber optics terms. Definitions for general fiber optics terms used in this standard practice are in accordance with EIA/TIA-440. Definitions for other terms as they are used in this standard practice are given in the following paragraphs.

3.2 Allocated and not used fiber. An allocated and not used fiber is a fiber that is designated for use for a particular system, but is not being used to transmit information. Allocated and not used fibers include fibers allocated as system spare fibers, system growth fibers, and system redundant fibers.

3.3 Allocated and used fiber. An allocated and used fiber is a fiber that is designated and required for use for a particular system link, and is being used to transmit information. Allocated and used fibers include fibers used for normal channels, fiber for alternate channels, and fibers for non redundant channels.

3.4 Alternate channel. An alternate channel is the allocated and used active backup link for a normal channel.

3.5 Authorized approval. Authorized approval is written approval from the cognizant Government activity.

3.6 End user equipment. End user equipment refers to any cabinet, case, panel, or device, that contains components that are either the origin or destination of an optical signal.

3.7 Fiber optic cable topology. The fiber optic cable topology consists of fiber optic interconnection boxes, outlets, trunk and local cables and the connectors and splices used to interconnect the trunk and local cables.

3.8 Installing activity. An installing activity is any military, commercial, or industrial organization involved with the installation of fiber optic cable topologies aboard Naval ships.

3.9 Local cable. A local cable is a fiber optic cable that provides a continuous optical path between an interconnection box (or outlet) and an end user equipment or between an interconnection box and an outlet, and is typically not run through the main cableways.

3.10 Minimum bend diameter. The minimum bend diameter of a fiber optic cable (and OFCC, see 3.15) is the radius at which the cable can be bent without degrading optical performance. The short term bend diameter applies during handling and installing; the long term bend diameter applies to the completed installation.

3.11 Multiple cable penetrator (MCP). A MCP provides a means for making watertight, airtight, and firetight penetrations through decks, bulkheads, and into equipment.

3.12 Non redundant channel (NRC). A non redundant channel is any allocated and used active link that has no system required backup link.

3.13 Normal channel. A normal channel is an allocated and used active link between system equipment that has a designated active backup link.

3.14 Optical fiber cable component (OFCC). An OFCC is a buffered fiber augmented with a concentric layer of strength members and an overall jacket.

3.15 Outlet. An outlet is a small termination box used to break out a local cable from and interconnection box to one or more equipments in a compartment or area.

3.16 Spare fiber. A fiber that is not allocated for use by any system, but is reserved for use as a maintenance spare in the case of damage to an allocated fiber within the cable. A system spare fiber is an allocated and not used fiber designated for a particular system.

3.17 Trunk cable. A trunk cable is a fiber optic cable that provides a continuous optical path between interconnection boxes. Typically, trunk cables are run in the main cableways and have higher fiber counts per cable than local cables.

3.18 Unused fiber. An unused fiber is a fiber that is not designated for use for any system and not required as part of the cabling. Unused fibers occur within the fiber optic cable topology when the required systems fibers are less than the number of fibers available within a standard cable size.

MIL-STD-2042-2A(SH)

4. GENERAL REQUIREMENTS

4.1 Fiber optic equipment installation. The methods specified herein are for installing the fiber optic cable topology equipment, which consists of interconnection boxes in accordance with MIL-I-24728. They may be extended to other fiber optic equipment only after obtaining authorized approval (see 3.5).

4.1.1 Interconnection box selection. The interconnection boxes selected shall be those identified in the ship specifications and drawings. Substitute boxes shall not be used without authorized approval (see 3.5). In those instances where the installing activity (see 3.8) is responsible for interconnection box selection, the box type shall be selected from MIL-I-24728. The box shall be sized to provide sufficient capacity to accept the total number of fibers entering the box (including growth fibers) as specified by the ship specification and system drawings. Unless otherwise specified in the ship specification or the system drawings, for boxes with both patch panels and splice trays, unused spaces can be any combination of patch panel or splice tray positions.

4.1.2 Location. Boxes shall be located in accordance with the system drawings. In those instances where the installing activity is responsible for selecting box location, the following requirements apply:

- a. In instances where a box interfaces directly with only one end user equipment, the box shall be located as close as possible to that equipment without interfering with any other systems or violating any other requirements specified herein. If a box interfaces directly with two or more end user equipments, the box shall be so located as to keep the majority of local cable (see 3.9) runs as short as possible. For end user equipment with local cables that are required to be survivably separated, the boxes that connect these local cables to trunk cables shall be located in different compartments, except for the case where the interconnection box and the equipment are in the same compartment. In this situation, both cables may be run from the equipment to the same box.
- b. Boxes shall be located in spaces protected from the weather whenever possible. Boxes shall not be installed in voids or inaccessible spaces. If mounting the box within gun or missile blast areas cannot be avoided, it shall be located clear of maximum deflection or whip of bulkheads and deck plating.
- c. Box location shall provide ready access and entry for maintenance. No part of the box shall be at a height greater than 7 feet above the deck, with the preferred maximum height being 5 feet. There shall be a minimum of 2 feet of clearance in front of the box.

4.1.3 Interconnection box mounting. Interconnection boxes shall be mounted in accordance with methods specified in 5.1.

4.1.3.1 Bonding, grounding, and shielding. Boxes that contain active fiber optic components, such as switches, shall be bonded, grounded, and shielded in accordance with MIL-STD-1310. Bonding, grounding, and shielding inside the box shall be in accordance with MIL-STD-1310 and MIL-STD-461.

4.1.3.2 Holes drilled in beams. Holes drilled in structural members for passing cables or securing equipment shall be on the neutral axis of the beam or between the neutral axis and the point of attachment. Reinforcement of holes, where required, shall be in accordance with the applicable ship specification.

4.1.3.3 Welding. Unless otherwise noted, welding of studs, step hangers, tapped pads, mounting pads, and extension hangers shall be in accordance with MIL-STD-278. Any required tapping shall be done before welding.

4.1.3.4 Fasteners. Material for the bolts, nuts, machine screws and washers used to fasten boxes to decks and bulkheads shall be as specified in the ship specification and drawings, and in the methods described herein. Locking devices in accordance with ship specifications shall be used for bolts that secure the boxes. Through-bolts and self-locking nuts shall be used to mount boxes located:

- a. In gun mounts.
- b. In missile launch areas.
- c. In submarine battery compartments above the level of the lowest cell tops.

4.1.3.5 Dissimilar metals. Where design requirements preclude the isolation of incompatible metal combinations, as identified in MIL-STD-889, from one another, the area in contact shall, as a minimum, be coated, treated, or otherwise insulated against corrosion in accordance with Appendix A of MIL-STD-889.

MIL-STD-2042-2A(SH)

4.2 Cable entrance to equipment. Fiber optic cables shall enter equipment in accordance with the methods described herein and as follows:

- a. Cables shall enter splashproof, spraytight, watertight, submersible, and explosionproof equipment through multiple cable penetrators (MCP's) integral to the equipment or through stuffing tubes. When stuffing tubes are used, entrance shall be made through the bottom or sides of the equipment where possible. Stuffing tubes used to enter splashproof, spraytight, or watertight equipment shall be nylon in accordance with MIL-S-19622. Stuffing tubes used to enter submersible (50 foot) and explosionproof equipment shall be metal in accordance with MIL-S-24235.
- b. Cables shall enter molded plastic equipment through nylon stuffing tubes.
- c. The entrance of cables via connector plugs and receptacles shall be as specified on the applicable ship or system drawings.
- d. The entrance and grounding of electrical cables using MCP's integral to the equipment shall be as specified on the applicable ship or system drawings.

4.2.1 Cable slack. Cables shall be secured to ship structure as close as possible to the equipment without violating cable long term bend diameter (see 3.10) requirements of not less than sixteen times the cable outside diameter (O.D.). Cables entering hard-mounted equipment shall have sufficient slack between the equipment and the last point of cable support, to prevent damage to the cable caused by vibration. Cables connected to equipment provided with resilient or shock mounts shall have a minimum length of 457 mm (18 inches) with not less than 76 mm (3 inches) of slack between the equipment and the last point of support of the cable to provide for flexibility and movement of the equipment under shock, vibration, and in-service loading. Cables terminated in a heavy duty (multiple terminus) connector shall have an additional minimum of 254 mm (10 inches) of slack in the cableway from which the cable exits to provide for two reconnections. For cables that enter equipment by way of stuffing tubes or MCP's, there shall be enough slack inside the equipment for a minimum of two reconnections. Where connectors are used for cable entrance to equipment, the cables shall be installed such that the connectors may be easily removed.

4.2.2 Cable forming and shaping. Optical Fiber Cable Components (OFCC's) and buffered fibers within interconnection boxes shall be routed around the inside edges of the box such that they do not block or otherwise obstruct access to any connections within the box. The group or bundle of OFCCs shall be protected from possible damage on sharp edges by using ties, clamps or tubing. Care shall be taken when attaching the group or bundle as shown in the methods herein to prevent kinking or cutting the OFCC jackets and to ensure that bends do not violate the OFCC minimum short term bend diameter of eight times the OFCC O.D. and the minimum long term bend diameter of sixteen times the OFCC O.D.

4.2.3 Splice assembly and alignment. The mating and alignment of splice ferrules shall be accomplished after they enter the interconnection box as specified herein. The fiber optic splice ferrules shall be installed on the buffered fibers in accordance with Method 5C1 in Part 5 of this standard practice.

4.2.4 Interconnection organization. Fiber optic splices shall be installed in the splice tray mounted in the interconnection box. The splice tray shall be in accordance with MIL-S-24623 and MIL-S-24623/4. Fiber optic connectors and adapters shall be mounted on the optical patch panels mounted in the interconnection box. The position of each connector or splice shall be in accordance with system drawings. Unterminated fibers shall be tied off in the bundle. The reservation of unused connection or splice spaces for unterminated fibers shall be as specified in the ship specification. If the installing activity is responsible for the internal configuration of the interconnection box, the configuration shall be in accordance with 4.2.4.1 and 4.2.4.2.

4.2.4.1 Connector organization. The individual patch panels shall be filled starting with the row closest to the inside of the box and working outward (see figure 2-1). Allocated fibers [normal, alternate, and NRC fibers (see 3.4, 3.12, and 3.13) and system growth and spare fibers] shall be located nearest the inside of the box. Spare fibers (see 3.16) shall be located in close proximity to their respective allocated fibers. Unused adapters shall be located closest to the outside of the box.

MIL-STD-2042-2A(SH)

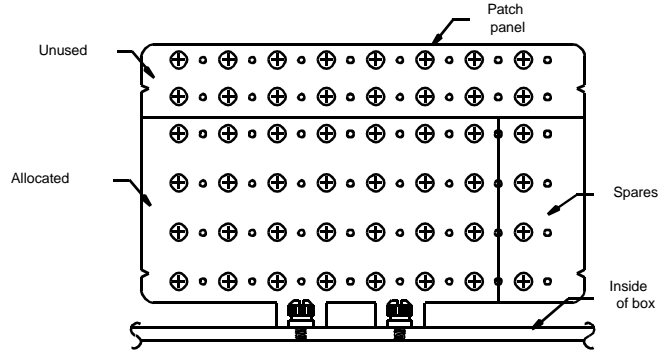

FIGURE 2-1. Configuration of patch panel - (typical).

4.2.4.2 Splice organization. The individual splice tray positions shall be filled starting with the tray position closest to the center of the box and working outward (see figure 2-2). Allocated fibers shall be located nearest the center of the box. Spare fibers shall be located in close proximity to their respective allocated fibers. Unused splice tray positions shall be located closest to the outside of the box. Each splice tray shall be filled starting closest to the rear of the box and working towards the front. Figure 2-3 shows typical splice tray configurations.

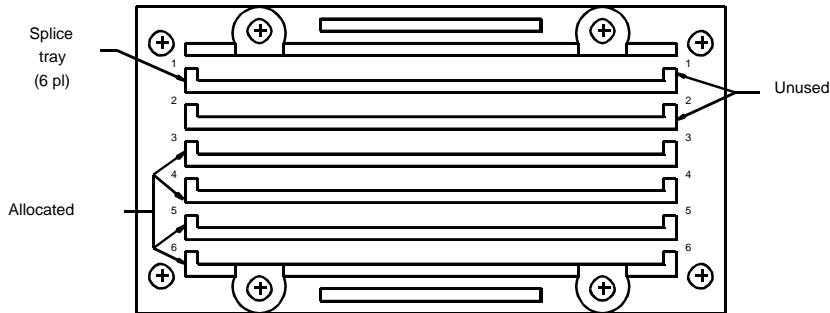

FIGURE 2-2. Configuration of splice module - (typical).

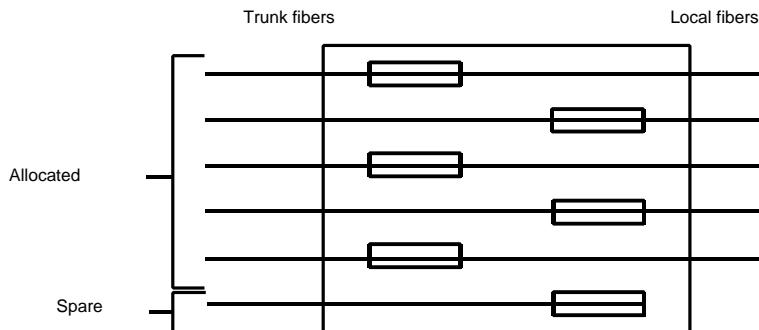

FIGURE 2-3. Configurations of splice tray - (typical).

4.2.5 Nameplates and marking. Nameplates shall be provided for all equipment and shall be in accordance with MIL-P-15024 and MIL-P-15024/5. Marking shall be as specified in the ship specification, applicable drawings, and the requirements herein. Interconnection box identification and location plates shall be located on the outside of the cover. Each connector or adapter position on the optical patch panels shall be marked. Splice trays shall be marked to identify each splice position, or a chart shall be attached in the box interior detailing the splice position numbers. A configuration chart showing all the

MIL-STD-2042-2A(SH)

connections within the box shall be permanently attached to the inside of the box lid. The input and output cable and fiber numbers and the connector or splice position number shall be shown for each connection. Cable marking at an equipment end shall be in accordance with Part 1 of this standard practice.

4.3 Safety precautions. The following safety precautions apply:

- a. Observe all written safety precautions given in the methods of this standard practice.
- b. Observe all warning signs on equipment and materials.
- c. The classification of a laser is based on the ability of the optical beam to cause damage to the eye. Under normal operating conditions, an optical fiber communication system (OFCS) is inherently an eye safe system; but, when an optical fiber connection is broken and optical viewing instruments are used, it is possible that hazardous energy can enter the eye. For this reason four service group hazard classes have been devised to indicate the degree of hazard and required hazard control measures. Refer to ANSI Z136.2 for a full technical definition. The following laser safety precautions shall apply:
 - (1) Ensure personnel are familiar with the laser degree of hazard and the required control measures.
 - (2) Light generated by light emitting diodes (LED's) and laser diodes may not be visible but may still be hazardous to the unprotected eye. Never stare into the end of an optical fiber connected to an LED or laser diode and do not stare into broken, severed or disconnected optical cables.
 - (3) Do not view the primary beam or a specular reflection from an OFCS with an optical microscope, eye loupe or other viewing instrument. The instrument may create a hazard due to its light gathering capability.
- d. Safety glasses shall be worn when handling bare fibers. Always handle cable carefully to avoid personal injury. The ends of optical fibers may be extremely sharp and can lacerate or penetrate the skin or cause permanent eye damage if touched. If the fiber penetrates the skin, it most likely will break off, in which case the extraction of the fiber should be performed by trained medical personnel to prevent further complications.
- e. Wash hands after handling bare fibers.

MIL-STD-2042-2A(SH)

5. DETAILED REQUIREMENTS

5.1 Fiber optic interconnection equipment installation. The methods covered here are applicable to the fiber optic interconnection boxes. They may be extended to other fiber optic interconnection equipment only after contacting the contracting activity. The mounting of these boxes on ship structure is the same as the standard mounting methods of electrical enclosures given in MIL-STD-2003-2. These methods will not be repeated in this standard practice; however, they are identified and listed here to aid the user in rapidly locating the applicable method in MIL-STD-2003-2 to be used for installing the fiber optic interconnection box.

5.1.1 Non-watertight decks and bulkheads. The following methods shall be used to install the interconnection box on non-watertight decks and bulkheads:

- a. Steel decks and bulkheads: MIL-STD-2003-2, Figure 2A1 or 2A4.
- b. Aluminum decks and bulkheads: MIL-STD-2003-2, Figure 2A6 or 2A8.

5.1.2 Watertight decks and bulkheads. The following methods shall be used to install the interconnection box on watertight decks and bulkheads:

- a. Steel decks and bulkheads: MIL-STD-2003-2, Figure 2A1 or 2A2.
- b. Aluminum decks and bulkheads: MIL-STD-2003-2, Figure 2A6 or 2A7.

5.1.3 Stanchions. The following methods shall be used to install the interconnection box on stanchions:

- a. Steel stanchion: MIL-STD-2003-2, Figure 2A5.
- b. Aluminum stanchion: MIL-STD-2003-2, Figure 2A9.

5.1.4 Metal joiner bulkheads. The following method shall be used to install the interconnection box on metal joiner bulkheads:

MIL-STD-2003-2, Figure 2A11.

5.1.5 Expanded metal or wire mesh bulkhead. The following methods shall be used to install the interconnection box on expanded metal or wire mesh bulkheads:

MIL-STD-2003-2, Figure 2A12 or 2A13.

5.1.6 Refrigerated spaces. The following method shall be used to install the interconnection box in refrigerated spaces:

MIL-STD-2003-2, Figure 2A16.

5.1.7 GRP (glass reinforced plastic) bulkheads. The following methods shall be used to install the interconnection box on GRP bulkheads:

MIL-STD-2003-2, Figure 2A23 or 2A24 and Figure 2A25.

5.1.8 Locking devices for installations on submarines. Locking devices of the following method shall be used in the installation of the interconnection box on submarines:

MIL-STD-2003-2, Figure 2A21.

5.2 Cable entrance to equipment. Fiber optic cable entrance into equipment may employ the same devices (that is, stuffing tubes and cable clamps) used for electric cable entrance into equipment. When these devices are used and the procedures are the same for both cable types, the methods will not be repeated in this standard practice. However, the methods are identified and listed here to aid the user in rapidly locating the applicable method in MIL-STD-2003. Methods unique to fiber optic cable or that differ from those for electric cable shall be in accordance with this standard practice.

5.2.1 Nylon stuffing tubes. Cable entry into spraytight, splashproof, molded plastic and watertight equipment via nylon stuffing tubes shall be in accordance with Method 2A1 in this part of this standard practice.

5.2.2 Multiple cable penetrator (MCP). Cable entry into equipment via integral MCP's shall be in accordance with Method 2B1 in this part of this standard practice.

5.2.3 Cable clamps. Cable entry into equipment via cable clamps shall not be permitted, unless given approval from the contracting activity.

MIL-STD-2042-2A(SH)

5.3 Interconnection organization. The organization of the splices, connectors and adapters and the shaping of the OFCC's and buffered fibers within the interconnection box shall be in accordance with Method 2C1 in this part of this standard practice.

5.4 Splice assembly and alignment. The interconnection of splice ferrules within the interconnection box shall be in accordance with Method 2D1 in this part of this standard practice.

MIL-STD-2042-2A(SH)

6. NOTES

(This section contains information of a general or explanatory nature that may be helpful, but is not mandatory.)

6.1 Intended use. The methods for equipment mounting and cable entrance to equipment depicted in this standard practice are intended primarily for new construction; however, they are applicable for conversion or alteration of existing ships.

6.2 Issue of DODISS. When this standard practice is used in acquisition, the applicable issue of the DODISS must be cited in the solicitation (see 2.2.1 and 2.3).

6.3 Standard method designation. To simplify the usage of this standard practice, an alpha-numeric designation system was developed to identify and locate a given method. The methods were grouped together by function as follows:

Group	A:	Cable entrance to equipment via nylon stuffing tubes.
	B:	Cable entrance to equipment via MCP.
	C:	Cable and buffered fiber forming and shaping.
	D:	Splice assembly and alignment.

Then the designation system was completed as follows:

$\frac{2}{*}$	$\frac{B}{*}$	$\frac{1}{*}$	-	*	
*	*	*	*	*	
*	*	*	.))))))		Alternate procedure within method
*	*	.))))))))))))		Method number within group
*	.))))))))))))))))))		Functional group
.))))))))))))))))))))))))		MIL-STD-2042 Part number

Thus, method 2B1 indicates there is no alternate procedure for method 1 of group B in Part 2 (MIL-STD-2042-2) of MIL-STD-2042.

6.4 Subject term (key word) listing.

Component
 Entrance into equipment
 Interconnection box
 Interconnection box selection
 Interconnection organization
 Nameplates and marking
 Splice assembly and alignment

Preparing activity:
 NAVY - SH
 (Project GDRQ-N169-2)

MIL-STD-2042-2A(SH)

METHOD 2A1

CABLE ENTRANCE TO EQUIPMENT VIA NYLON STUFFING TUBES

1. SCOPE.

1.1 Scope. This method describes a procedure for fiber optic cable entry to fiber optic cable topology and other equipment through nylon stuffing tubes.

2. REQUIRED EQUIPMENT AND MATERIALS.

2.1 The equipment and materials in table 2A1-I shall be used to perform this procedure:

TABLE 2A1-I. Equipment and materials.

Description	Quantity
Safety glasses	1
Ruler	1
Deburring tool (or equivalent)	1
Paint scraper	1
Emery cloth	As required
Cable jacket stripping tool (NAVSEA DWG 6872812-08 or equal)	1
Kevlar shears (NAVSEA DWG 6872812-16 or equal)	1
Open end wrench (sized to fit locknut)	1
Spanner wrench (sized to fit cap)	1
RTV silicone rubber (Silastic 731731 or equal)	As required
Primer (type to suit metal)	As required
Talc (soap stone)	As required
Alcohol bottle with alcohol/2-propanol	1
Wipes	As required
Canned air (or compressed air)	As required

3. PROCEDURE.

3.1 Safety summary. The following safety precautions shall be observed:

- a. Safety glasses shall be worn at all times when handling bare fibers.
- b. Do not touch the ends of bare fiber as they may be razor sharp. Wash your hands thoroughly after handling bare fibers.
- c. Do not stare into the end of a fiber until verifying that the fiber is not connected to a laser light source or LED.

3.2 Procedure.

NOTE: Packing assemblies and "O"-rings are not furnished with stuffing tubes. They must be ordered separately by the installing activity to suit installations.

- Step 1 - Select the stuffing tube, packing and "O"-ring in accordance with tables 2A1-II and 2A1-III.

MIL-STD-2042-2A(SH)

TABLE 2A1-II. Nylon stuffing tube sizes for fiber optic cable.

Cable type	Cable O.D. mm (inches) nominal	Tube size	Packing assembly part no. M19622/	Packing assembly opening mm (inches)
4-Fiber	8.1 (0.32)	2	17-0001	8.26 (0.325)
8-Fiber	11.1 (0.44)	3	18-0018	12.0 (0.472)
36-Fiber	20.8 (0.82)	5	20-0003	21.7 (0.853)

TABLE 2A1-III. Nylon stuffing tube data.

Stuffing tube sizes		Tube size 2	Tube size 3	Tube size 5
Straight tube	Tube part number M19622/	1-002	1-003	1-0006
	"O"-ring part number MS28775-	214	216	226
Angle tube	Tube part number M19622/	2-002	2-003	2-006
	"O"-ring part number MS28775-	212	216	226
NPT Tube	Tube part number M19622/	3-002	3-003	3-005
	NPT Tap mm (inches)	19 (0.75)	25 (1.0)	38 (1.5)
"y" Tube	Tube part number M19622/	4-02	4-03	N/A
	"O"-ring part number MS28775-	214	216	N/A

- Step 2 - **WARNING:** Wear safety glasses during deburring to avoid possible eye injury. Inspect the hole in the enclosure and remove any burrs or irregularities using the deburring tool.
- Step 3 - For steel enclosures where the roughness is greater than a 125 microinch finish (not required on aluminum enclosures), remove the paint using a paint scraper and clean the surface with emery paper approximately 13 mm (0.5 inch) wide around the hole on the exterior of the enclosure. Apply one coat of primer, and allow to set. Dust coat the surface with talc if the primer is not thoroughly dried at the time of the tube installation. Remove the cover and proceed to step 4, 5 or 7 below, as applicable.
- Step 4 - With straight tubes, insert the stuffing tube body into the hole from the inside of the enclosure (see figure 2A1-1). If necessary, remove the interior fitting from enclosure. Proceed to step 6 below.

MIL-STD-2042-2A(SH)

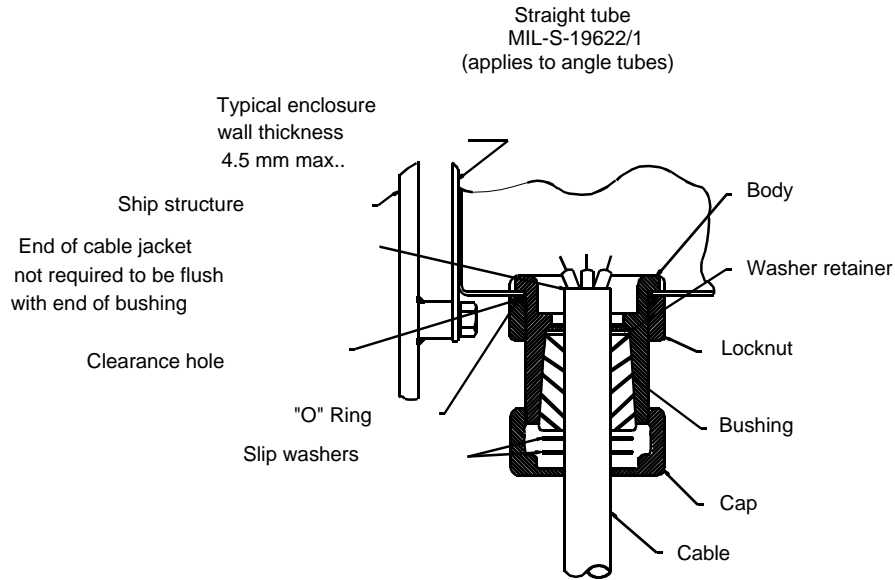

FIGURE 2A1-1. Straight tube.

- Step 5 - With "Y" and angle tubes, insert the stuffing tube body into the hole from the outside of enclosure (see figures 2A1-2 and 2A1-3). The excess length protruding into the enclosure may be removed.

"Y" Tube 45 degree angle
MIL-S-19622/4

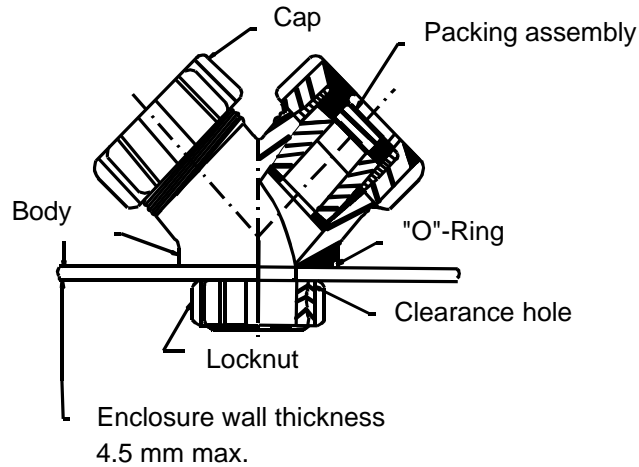
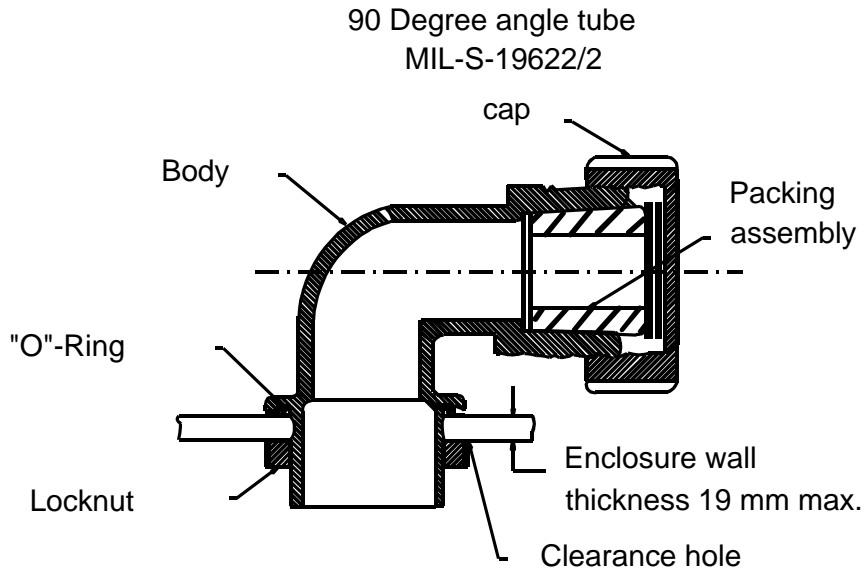
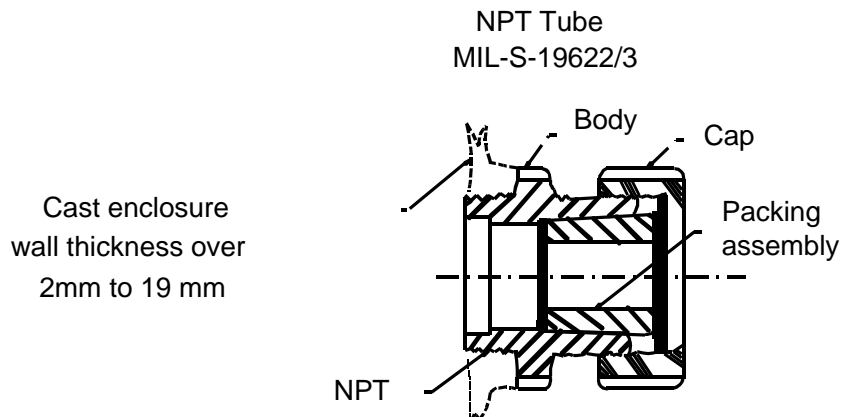

FIGURE 2A1-2. "Y" (45°) tube.

MIL-STD-2042-2A(SH)

FIGURE 2A1-3. 90° angle tube.

- Step 6 - Screw the locknut onto the body and tighten with a wrench against the "O"-ring sufficiently to obtain plastic to metal contact of the stuffing tube and the enclosure. In cases where this plastic to metal contact cannot be obtained, tighten the locknut until the threads start to skip. This is considered a satisfactory indication of tightness. (Note Hold the stuffing tube body while tightening the locknut to prevent turning.) Proceed to step 8 below.
- Step 7 - With NPT tubes, screw the tube into the enclosure pipe thread and tighten it sufficiently to obtain a seal at the threads (see figure 2A1-4).

FIGURE 2A1-4. NPT tube.

- Step 8 - Measure the length of the cable jacket to be removed:
- For unterminated cables, measure the distance required to route OFCCs from innermost portion of the stuffing tube completely around the interior of the interconnection box (or to the furthestmost connection point in the end user equipment), add approximately 127 mm (5 inches) and mark cable outer jacket.

MIL-STD-2042-2A(SH)

For terminated cable assemblies, measure the distance required to route OFCCs from innermost portion of the stuffing tube to the furthestmost connection point in the equipment, add approximately 76 mm (3 inches) and mark cable outer jacket. In an interconnection box the distance measured shall be great enough that the OFCC can be routed one-half of the way around the box and then to the termination point.

- Step 9 - Slide the stuffing tube parts onto cable in the order indicated:
- a. Cap
 - b. Two slip washers
 - c. Rubber bushing
 - d. Bottom washer
- Step 10 - Slide the parts up the cable beyond the mark and, if not already done, remove the outer jacket up to the mark using the cable stripper.
- CAUTION: Do not cut or nick OFCC's.
- Cut off the cable kevlar strength members and exposed central member, if present, using kevlar shears.
- NOTE: If cable strength member capture is planned, leave approximately 102 mm (4 inches) of the kevlar strength members protruding from the cable jacket.
- Step 11 - Remove the waterblocking material and clean the OFCC's using a wipe dampened with alcohol. Blow dry with air.
- Step 12 - Insert the cable through the stuffing tube and into the enclosure so that the outer jacket protrudes 12 mm to 25 mm (0.5 in to 1 inch) inside the equipment. Slide the washers and bushing down the cable into the tube (NOTE: When necessary to pass an airtight test, apply RTV silicone rubber to the bushing.)
- Step 13 - Slide the cap down the cable, screw it onto the tube and tighten it sufficiently using the spanner wrench to compress the bushing to form a tight seal between the cable and the tube. (NOTE: Hold the tube body when tightening the cap to prevent breaking the watertight seal.) After the bushing has been compressed for approximately 24 hours, retighten it to ensure the seal is maintained.
- Step 14 - If required, wind the exposed kevlar strength member under a screw lug attached beside the stuffing tube and tighten the screw lug.
- Note: This step is only performed when additional strain relief is required beyond that provided by the stuffing tube assembly.
- NOTE: Sealing plugs are for use in service to seal nylon stuffing tubes from which cables have been removed. When installing sealing plugs, the cable bushing shall be discarded but the nylon washers shall be retained and left in the stuffing tube.
- Step 15 - Install connectors and splice ferrules on the OFCCs as specified on the system drawings using Method 5B1 in Part 5 of this standard practice for connectors and Method 5C1 in Part 5 of this standard practice for splice ferrules.

MIL-STD-2042-2A(SH)

METHOD 2B1

CABLE ENTRANCE TO EQUIPMENT VIA MCP

1. SCOPE.

1.1 Scope. This method describes a procedure for fiber optic cable entry to fiber optic cable topology and other equipment through multiple cable penetrators (MCP) integral to the equipment being entered. Procedures for electrical cable entry and grounding to equipment through MCPs integral to the equipment shall be as specified on the applicable ship or system drawings.

2. REQUIRED EQUIPMENT AND MATERIALS.

2.1 The equipment and materials in table 2B1-I shall be used to perform this procedure.

TABLE 2B1-I. Equipment and materials.

Description	Quantity
Safety glasses	1
Ruler	1
Tallow (Hevi-Duty/Nelson AA0099 or equal)	As required
Open end wrench (sized to fit wedgepack nut)	1
Cable jacket stripping tool (NAVSEA DWG 6872812-08 or equal)	1
Kevlar shears (NAVSEA DWG 6872812-16 or equal)	1

3. PROCEDURE.

3.1 Safety Summary. The following safety precautions shall be observed:

- a. Safety glasses shall be worn at all times when handling bare fibers.
- b. Do not touch the ends of bare fiber. Wash hands thoroughly after handling bare fibers.
- c. Do not stare into the end of a fiber until verifying that the fiber is not connected to a laser light source or LED.

3.2 Procedure.

Step 1 - Select MCP blocks in accordance with table 2B1-II.

Step 2 - Measure the length of the cable jacket to be removed:

For unterminated cables, measure the distance required to route OFCCs from innermost portion of the MCP completely around the interior of the interconnection box (or to the furthestmost connection point in the end user equipment), add approximately 127 mm (5 inches) and mark the cable outer jacket.

For terminated cable assemblies, measure the distance required to route OFCCs from innermost portion of the MCP to the furthestmost connection point in the equipment, add approximately 76 mm (3 inches) and mark the cable outer jacket. In an interconnection box the distance measured shall be great enough that the OFCC can be routed one-half of the way around the box and then to the termination point.

Step 3 - Remove the outer jacket up to the mark using the cable stripper.

CAUTION: Do not cut or nick OFCC's.

Cut off the cable kevlar strength members and exposed central member, if present, using kevlar shears.

Step 4 - Remove the waterblocking material and clean the OFCC's using a wipe dampened with alcohol. Blow dry with air.

MIL-STD-2042-2A(SH)

TABLE 2B1-II. MCP data and insert block sizes for fiber optic cables

Cable type	4-Fiber	8-Fiber	36-Fiber
Cable O.D. mm (inches) nominal	8.1 (0.32)	11.1 (0.44)	20.8 (0.82)
Primary insert block part number M24705/1-BN	1508	2011	3021
Alternate insert block part number M24705/1-BN	2008	N/A	N/A
Blanking insert block part number M24705/1-BN	15	20	30
Alternate blanking insert block part number M24705/1-BN	20	N/A	N/A

- Step 5 - **CAUTION:** Do not exceed the cable minimum bend diameter of eight times cable O.D. for short term bends and sixteen times the cable O.D. for long term bends.

Feed the cables into the interconnection box or the other equipment through the cable penetration opening.

- Step 6 - Liberally apply tallow to the outside portion of the insert blocks, the inner portion of the MCP frame and to the sides of the wedgepack. Make sure that tallow is placed in the corners of the MCP frame. (NOTE: The wedgepack may be removed and disassembled to apply the tallow.)

- Step 7 - Reinstall the wedgepack (if removed) and install the insert blocks on the cables so that the outer jacket protrudes 13 mm (0.5 inch) to 25 mm (1 inch) inside the equipment. Install the cable insert blocks so that the gap between the insert block halves is parallel to the wedge pack. Install the insert blocks into the MCP frame so that the insert blocks are flush with the outside edge of the MCP frame. Fill all positions in the frame with insert blocks [either cable insert blocks or blanking (solid) insert blocks (see figure 2B1-1)]. (NOTE: Incoming cables may be installed on one end of the enclosure and outgoing cables on the opposite end for large enclosures. Where only one penetrator is used, incoming cables may be installed on one side of the wedgepack and outgoing cables on the opposite side.)

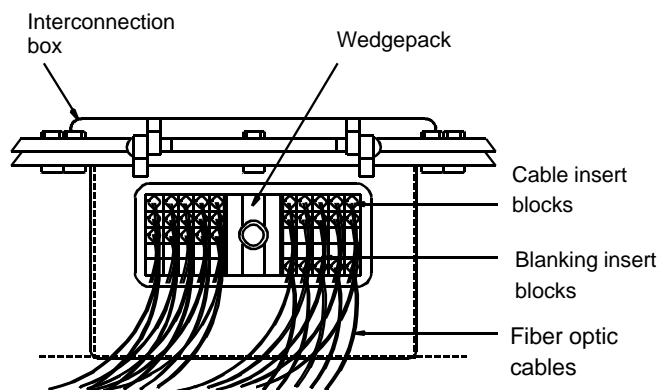
FIGURE 2B1-1. Interconnection box integral MCP-(typical).

- Step 8 - Tighten the nut on the wedgepack to compress the insert blocks in the frame using a wrench. Tighten the wedgepack nut until the outside wedge pack metal plate is almost flush with the bottom of the MCP frame and the insert blocks. (NOTE: The wedge pack is fully tightened when the length of the pack is the same as the depth of the MCP frame.) Continue to tighten the wedgepack nut until a torque between 5.7 and 16.9 N-m (50 and 150 in-lbs) is reached. After the blocks have been compressed for approximately 24 hours, retighten the nut to ensure that the seal is maintained.

MIL-STD-2042-2A(SH)

- Step 9 - Install connectors and splice ferrules on the OFCCs as specified on the system drawings using Method 5B1 in Part 5 of this standard practice for connectors and Method 5C1 in Part 5 of this standard practice for splice ferrules.

MIL-STD-2042-2A(SH)

METHOD 2C1

CABLE AND BUFFERED FIBER FORMING AND SHAPING

1. SCOPE.

1.1 Scope. This method describes a procedure for the forming and shaping of the optical fiber cable components (OFCC) and buffered fibers within the interconnection box and installation of connectors and splices in patch panels and splice trays, respectively.

2. REQUIRED EQUIPMENT AND MATERIALS.

2.1 The equipment and materials in table 2C1-I shall be used to perform this procedure.

TABLE 2C1-I. Equipment and materials.

Description	Quantity
Safety glasses	1
Ruler	1
Self-clinching straps (MIL-S-23190 or commercial)	As required
Lacing (Nylon or equal)	As required
Synthetic tubing	As required
Heat shrink tubing (MIL-T-23053/5)	As required
Heat gun (Raychem 500B or equal)	1
Open end wrench	1
Alcohol bottle with alcohol/2-propanol	1
Wipes (NAVSEA DWG 6872812-18 or equal)	As required
Canned air (NAVSEA DWG 6872812-17 or equal)	As required

CAUTION: Throughout the fabrication process, cleanliness is critical to obtaining a high optical quality splice. Make sure that your hands and the work area are as clean as possible to minimize the ingress of dirt into the connectors and splices.

3. PROCEDURE.

3.1 Safety summary. The following safety precautions shall be observed:

- a. Safety glasses shall be worn at all times when handling bare fibers.
- b. Do not touch the ends of bare fiber. Wash hands thoroughly after handling bare fibers.
- c. Do not stare into the end of a fiber until verifying that the fiber is not connected to a laser light source or LED.

3.2 Procedure.3.2.1 Forming and shaping.

- Step 1 - Verify that the procedures of Method 2A1 or Method 2B1 of this standard practice have been completed.
- Step 2 - Open the enclosure cover and visually examine the OFCC's for cuts, nicks, kinks or twists before forming them into groups.
- Step 3 - **CAUTION:** Do not exceed the bend diameter of eight times the OFCC O.D. for short term bends and sixteen times the OFCC O.D. for long term bends.

Observe the connection configuration chart or other approved drawing and form the fibers into groups based on their final destination. Groups may then be formed into bundles and shaped using lacing or self-clinching straps in accordance with MIL-STD-2003-1, Figures 1B5 and 1B6

MIL-STD-2042-2A(SH)

respectively. Lace or strap the groups loosely; do not tighten down the straps with the hand tool.

- Step 4 - Route the fiber bundles around the box securing them to the box mounting brackets using the self-clinching straps. Observe the following during routing (see figure 2C1-1):
- a. All OFCCs shall be routed one-half of the way around the box and then to the termination point.
 - a. When a direct route to a termination point would exceed the OFCC long term bend diameter of sixteen times the OFCC O.D., an indirect route shall be used.
 - b. Groups and bundles shall not cross the splice trays or patch panels or in any other way obstruct access to the individual connectors, splices or adapters. Groups and bundles may be routed between the splice tray or connector patch panel modules, if necessary.
 - c. Groups and bundles shall be protected from possible damage by sharp edges by the use of supporting brackets or by synthetic tubing at the point of the sharp edge.

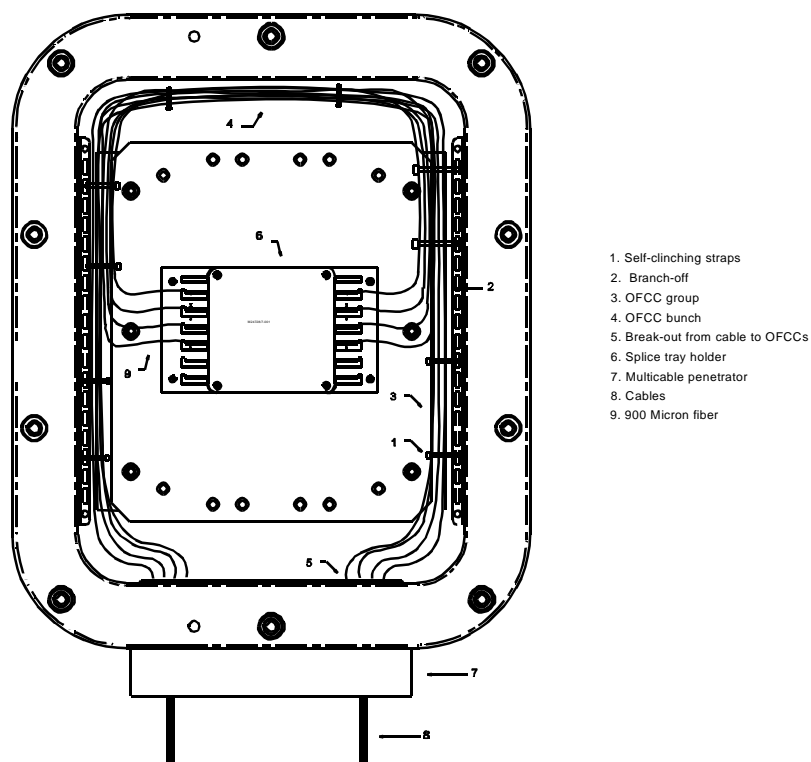

FIGURE 2C1-1. Forming and shaping - (typical).

- Step 5 - Break out each separate OFCC from the group or bundle and, if not already done, slide the heat shrink tubing with the fiber identification over the connector or splice onto the OFCC cable jacket.
- Note: The heat shrink tubing should normally be pushed up the OFCC before the OFCC is terminated. If the heat shrink is not put on before the connector or splice, heat shrink is available that can be installed after the connector or splice is installed.
- Note: Do not install heat shrink tubing on 900 micron fibers. In those cases where 900 micron fiber is present going into a splice, the tubing should be installed in a region where there is an OFCC.
- Step 6 - **CAUTION:** Do not overheat the OFCC. Prolonged exposure of the OFCC jacket to temperatures in excess of 160 degrees Celsius (°C) [320 degrees Fahrenheit (°F)] may damage the OFCC jacket. Discontinue heating of the tubing and allow the OFCC jacket to cool before reheating if the OFCC jacket shows any signs of bubbling.

MIL-STD-2042-2A(SH)

Holding the heat gun approximately 102 mm (4 inches) away from the OFCC and tubing, shrink the tubing.

- Step 7 - Form the unterminated OFCC bundles into a loop around the complete interior of the box being careful not to kink or otherwise damage the OFCCs and end seal the bundles in accordance with Part 1 of this Standard practice. Tie off the unterminated bundles such that they will not obstruct access to other components.

Note: Do not group or bundle the unterminated OFCCs with the terminated OFCCs. Unterminated OFCCs should be independently grouped, bundled and strapped to the box mounting brackets from the terminated OFCCs.

- Step 8 - Proceed to 3.2.2 below to install connectors in patch panels. Proceed to 3.2.3 below to install splices in splice trays.

3.2.2 Connector installation in patch panel.

- Step 1 - Unscrew the two screws holding the patch panel and pull the panel forward until it catches in the slide. (NOTE: The panel can be completely removed by pulling it through the catch.)

NOTE: Use a wipe dampened with alcohol to clean all connectors and blow them dry with air before making connections.

- Step 2 - Insert one connector into the adapter mounted in the patch panel and lock it into place with the bayonet fitting. (This is accomplished by aligning the key on the connector barrel with the keyway on the adapter, inserting the connector in the adapter, engaging the bayonet coupling mechanism and rotating the connector clockwise until it stops.)

- Step 3 - Insert the mating connector into the opposite side of adapter and lock it into place.

- Step 4 - Repeat steps 2 and 3 above until all of the connectors are installed. Push the panel back into the box and tighten the screws.

- Step 5 - Close and secure the cover.

3.2.3 Splice installation in splice tray.

- Step 1 - Unscrew the four screws holding the splice tray holder cover, pull the splice tray forward and remove it from the holder. Remove the splice tray cover.

- Step 2 - Place the ends of splice compression tool into the slots on the splice ferrule collars and squeeze the tool to compress the ferrule springs (see figure 2C1-2).

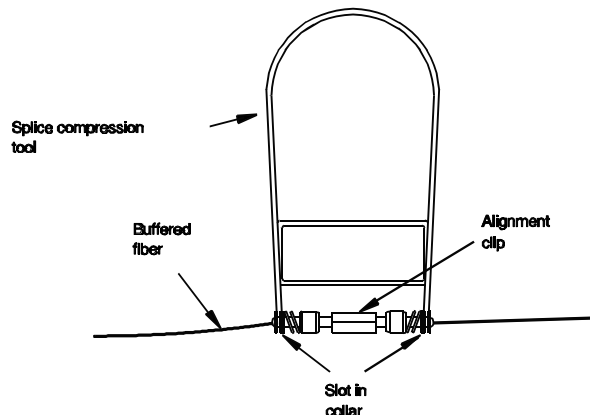

FIGURE 2C1-2. Compressing ferrule springs.

MIL-STD-2042-2A(SH)

- Step 3 - Carefully place the splice into the splice tray with the open slot in the splice alignment sleeve facing upward (see figure 2C1-3). Ensure the ferrule ends are completely inside the tray and that the buffered fibers are carefully routed in the tray slots.

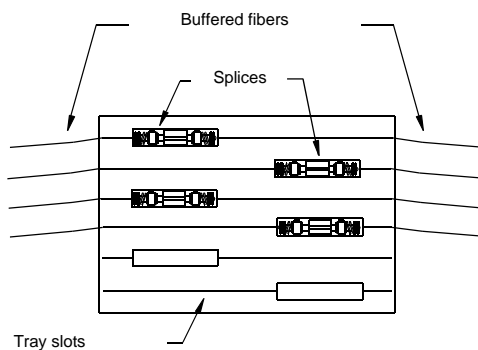

FIGURE 2C1-3. Splices installed in splice tray - (typical).

- Step 4 - Repeat steps 2 and 3 above until all of the splices are installed in the tray. Place the splice tray cover over the splice tray and reinstall the tray into the holder. Repeat the above procedures for each tray, as required.
- Step 5 - Replace the tray holder cover and tighten the holder cover screws.
- Step 6 - Close and secure the enclosure cover using a wrench.

MIL-STD-2042-2A(SH)

METHOD 2D1

SPLICE ASSEMBLY AND ALIGNMENT

1. SCOPE.

1.1 Scope. This method describes a procedure for mating and aligning optical fibers terminated with MIL-S-24623/4 splice ferrules to form a continuous optical signal path.

2. REQUIRED EQUIPMENT AND MATERIALS.

2.1 The equipment and materials in table 2D1-I shall be used to perform this procedure.

TABLE 2D1-I. Equipment and materials.

Description	Quantity
Safety glasses	1
Index matching gel (MIL-M-24794)	As required
Alignment clip tool (NAVSEA DWG 6872812-01 or equal)	1
Splice alignment tool (NAVSEA DWG 6872812-05 or equal)	1
Test jumpers (in accordance with table 6C1-III in Part 6 of this standard practice)	As required
Optical loss test set (NSN 7Z 6625 01 304 1739) or equal	1
Alcohol bottle with alcohol/2-propanol	1
Wipes (NAVSEA DWG 6872812-18 or equal)	As required

CAUTION: Throughout the fabrication process, cleanliness is critical to obtaining a high optical quality splice. Make sure that your hands and the work area are as clean as possible to minimize the ingress of dirt into the splice.

3. PROCEDURE.

3.1 Safety summary. The following safety precautions shall be observed:

- a. Safety glasses shall be worn at all times when handling bare fibers.
- b. Do not touch the ends of the fiber. Wash your hands thoroughly after handling bare fibers.
- c. Do not stare into the end of a fiber until verifying that the fiber is not connected to a laser light source or an LED.

3.2 Procedure.3.2.1 Splice assembly.

Step 1 - Mix a small portion of the index matching gel on a clean surface according to the manufacturer's instructions provided (vacuuming is not required).

Note: The index matching gel provided may be a one part gel that does not require mixing.

Step 2 - CAUTION: Opening the sleeve too much may damage the sleeve.

Adjust the splice alignment clip tool so that it opens the splice alignment clip just enough to insert the splice ferrules. Insert the tool tip into the alignment sleeve slot. Open the sleeve (see figure 2D1-1).

MIL-STD-2042-2A(SH)

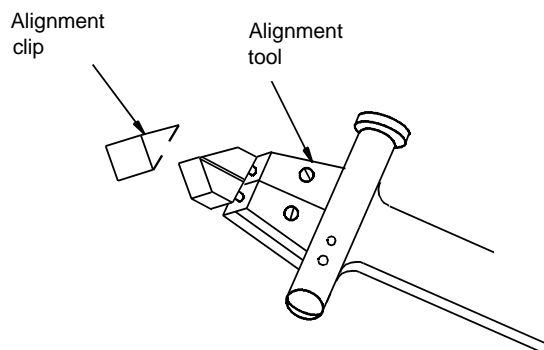
FIGURE 2D1-1. Opening alignment sleeve.

- Step 3 - Dip one of the polished ferrule tips into the gel and slide the ferrule into the alignment clip until the tip is approximately centered in the clip (see figure 2D1-2).

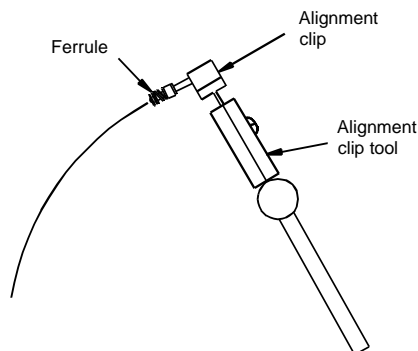
FIGURE 2D1-2. Inserting ferrule into alignment sleeve.

- Step 4 - Dip the other ferrule tip into the index matching gel and slide the ferrule tip into the other side of the alignment clip (see figure 2D1-3). Ensure that the ferrule tips are centered in the alignment clip and the alignment tabs are facing the clip gap. Remove the alignment clip tool. Verify that the ferrule tips are in contact by pushing the ferrules together.

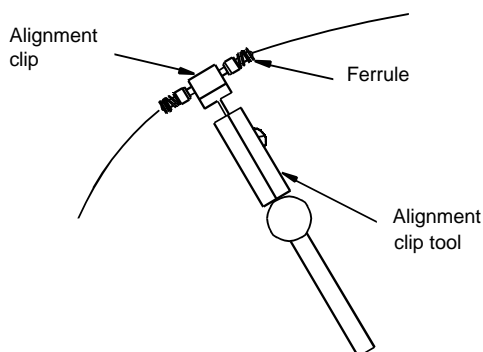
FIGURE 2D1-3. Inserting second ferrule into alignment sleeve.

MIL-STD-2042-2A(SH)

3.2.2 Splice alignment.

NOTE: Passive alignment should be sufficient for most applications. Active alignment shall only be performed when required to meet link acceptance requirements.

Proceed to step 1 below for passive alignment or proceed to step 2 below for active alignment.

- Step 1 - Passive alignment - verify the tab alignment by inserting the splice assembly into the splice alignment tool making sure the tabs fit into the tool slots (see figure 2D1-4). If necessary, rotate either ferrule slightly to align the tabs. Remove the splice from the tool.

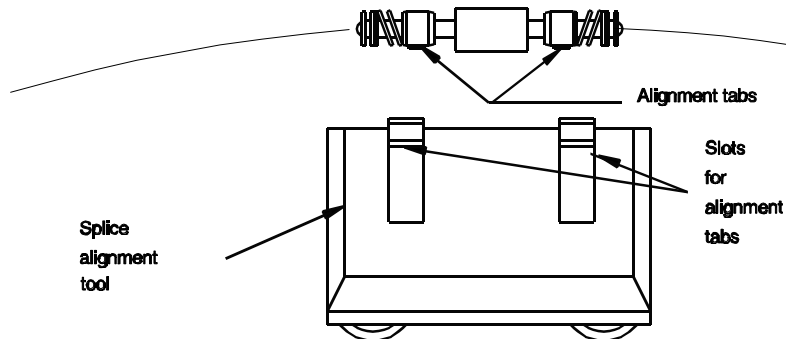

FIGURE 2D1-4. Aligning tabs.

- Step 2 - Active alignment -

WARNING: Do not stare into the end of a fiber connected to an LED or laser diode. Light may not be visible but can still damage the eye.

Using the appropriate test adapters or test jumper cables in accordance with table 6C1-III in Part 6 of this standard practice, connect the cable ends opposite the splice ferrules of cable under test to the light source and detector of two optical loss test sets and energize both (see figure 2D1-5).

Note: Both optical loss test sets should be allowed to warm up before starting the active alignment so that the readings are stable.

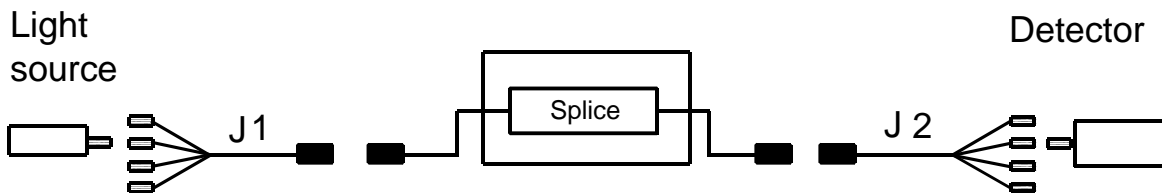

FIGURE 2D1-5. Active splice alignment cable hookup.

- Step 3 - Rotate the ferrules relative to each other until the maximum power is recorded at the optical detector. De-energize the optical loss test sets.

STANDARDIZATION DOCUMENT IMPROVEMENT PROPOSAL

INSTRUCTIONS

1. The preparing activity must complete blocks 1, 2, 3, and 8. In block 1, both the document number and revision letter should be given.
2. The submitter of this form must complete blocks 4, 5, 6, and 7.
3. The preparing activity must provide a reply within 30 days from receipt of the form.

NOTE: This form may not be used to request copies of documents, nor to request waivers, or clarification of requirements on current contracts. Comments submitted on this form do not constitute or imply authorization to waive any portion of the referenced document(s) or to amend contractual requirements.

I RECOMMEND A CHANGE:

1. DOCUMENT NUMBER

MIL-STD-2042-2A(SH)

2. DOCUMENT DATE (YYMMDD)

970929

3. DOCUMENT TITLE

FIBER OPTIC CABLE TOPOLOGY INSTALLATION STANDARD METHODS FOR NAVAL SHIPS (EQUIPMENT)

4. NATURE OF CHANGE (Identify paragraph number and include proposed rewrite, if possible. Attach extra sheets as needed.)

5. REASON FOR RECOMMENDATION

6. SUBMITTER

a. NAME (Last, First, Middle Initial)

b. ORGANIZATION

c. ADDRESS (Include Zip Code)

d. TELEPHONE (Include Area Code)

(1) Commercial
(2) AUTOVON
(If applicable)7. DATE SUBMITTED
(YYMMDD)

8. PREPARING ACTIVITY

a. NAME

THE TECHNICAL POINT OF CONTACT IS:
DR. CHARLES COURCHAINÉ 03J2

b. TELEPHONE (Include Area Code)

(1) Commercial
(703) 602-7241(2) AUTOVON
332-7241

c. ADDRESS (Include Zip Code)

Commander, Naval Sea Systems Command, SEA 03R42
2531 Jefferson Davis Hwy.
Arlington, VA 22242-5160**IF YOU DO NOT RECEIVE A REPLY WITHIN 45 DAYS, CONTACT:**Defense Quality and Standardization Office
5203 Leesburg Pike, Suite 1403, Falls Church, VA 22041-3466
Telephone (703) 756-2340 AUTOVON 289-2340