

INCH-POUND

MIL-STD-2003-5B(SH)

6 October 2020

SUPERSEDING

MIL-STD-2003-5A(SH)

3 September 2009

**DEPARTMENT OF DEFENSE
STANDARD PRACTICE
ELECTRIC PLANT INSTALLATION
STANDARD METHODS FOR
SURFACE SHIPS AND SUBMARINES
(CONNECTORS)**



MIL-STD-2003-5B(SH)

FOREWORD

1. This standard is approved for use by the Naval Sea Systems Command, Department of the Navy, and is available for use by all Departments and Agencies of the Department of Defense.
2. This standard disseminates up-to-date information detailing requirements for standard installation methods for connectors employed for submarine and surface ship electrical distribution systems.
3. These criteria are for application to new construction, conversion, and alteration of existing ships.
4. Comments, suggestions, or questions on this document should be addressed to Commander, Naval Sea Systems Command, ATTN: SEA 05S, 1333 Isaac Hull Avenue, SE, Stop 5160, Washington Navy Yard DC 20376-5160 or emailed to CommandStandards@navy.mil, with the subject line "Document Comment". Since contact information can change, you may want to verify the currency of this address information using the ASSIST Online database at <https://assist.dla.mil>.

MIL-STD-2003-5B(SH)

CONTENTS

<u>PARAGRAPH</u>	<u>PAGE</u>
1. SCOPE.....	1
1.1 Scope.....	1
1.1.1 Application.....	1
2. APPLICABLE DOCUMENTS.....	1
2.1 General.....	1
2.2 Government documents.....	1
2.2.1 Specifications, standards, and handbooks.....	1
2.2.2 Other Government documents, drawings, and publications.....	1
2.3 Non-Government publications.....	1
2.4 Order of precedence.....	2
3. DEFINITIONS.....	2
4. GENERAL REQUIREMENTS.....	2
4.1 Instructions for use of MIL-STD-2003-5.....	2
4.2 Or equal.....	2
4.3 Consideration of electromagnetic shielding.....	2
4.4 Use of connectors not covered in MIL-STD-2003-5.....	2
4.5 Connector post-installation retests.....	2
4.6 Inactive for new design documents.....	3
4.7 Workmanship and inspection guidance.....	3
4.8 Hazardous materials.....	3
4.9 The terms agreement or approval.....	3
5. DETAILED REQUIREMENTS.....	3
6. NOTES.....	3
6.1 Intended use.....	3
6.2 Acquisition requirements.....	3
6.3 Designation of electric plant installation standard methods figures.....	3
6.4 Subject term (key word) listing.....	4
6.5 Changes from previous issue.....	4
APPENDIX 5A – CABLE LEAD PREPARATION.....	5
A.1 SCOPE.....	5
A.1.1 Scope.....	5
A.2 APPLICABLE DOCUMENTS.....	5
A.2.1 General.....	5
A.2.2 Government documents.....	5
A.2.2.1 Specifications, standards, and handbooks.....	5
A.2.2.2 Other Government documents, drawings, and publications.....	6
A.2.3 Non-Government publications.....	6
A.2.4 Order of precedence.....	8
A.3 REQUIRED EQUIPMENT AND MATERIALS.....	8
A.3.1 Required equipment and materials.....	8
A.4 NOTES AND PROCEDURES.....	8
A.4.1 Dimensions.....	8
A.4.2 Figures.....	8
APPENDIX 5B – MIL-C-81511/SAE-AS81511 SERIES 1 AND 2 GANG CONTACT RELEASE CONNECTOR ASSEMBLY PROCEDURE.....	92
B.1 SCOPE.....	92
B.1.1 Scope.....	92
B.2 APPLICABLE DOCUMENTS.....	92
B.2.1 General.....	92

MIL-STD-2003-5B(SH)

B.2.2	Government documents.	92
B.2.2.1	Other Government documents, drawings, and publications.	92
B.2.3	Non-Government publications.	92
B.2.4	Order of precedence.	93
B.3	REQUIRED EQUIPMENT AND MATERIALS	93
B.3.1	Required equipment and materials.	93
B.4	NOTES AND PROCEDURES	93
B.4.1	Dimensions.	93
B.4.2	Figures.	93
APPENDIX 5C – MIL-DTL-5015/SAE-AS50151	CONNECTORS	116
C.1	SCOPE	116
C.1.1	Scope.	116
C.2	APPLICABLE DOCUMENTS	116
C.2.1	General.	116
C.2.2	Government documents.	116
C.2.2.1	Specifications, standards, and handbooks.	116
C.2.2.2	Other Government documents, drawings, and publications.	116
C.2.3	Non-Government publications.	116
C.2.4	Order of precedence.	117
C.3	REQUIRED EQUIPMENT AND MATERIALS	117
C.3.1	Required equipment and materials.	117
C.4	NOTES AND PROCEDURES	117
C.4.1	Dimensions.	117
C.4.2	Figures.	117
APPENDIX 5D – MIL-DTL-26482	CONNECTORS	143
D.1	SCOPE	143
D.1.1	Scope.	143
D.2	APPLICABLE DOCUMENTS	143
D.2.1	General.	143
D.2.2	Government documents.	143
D.2.2.1	Specifications, standards, and handbooks.	143
D.2.2.2	Other Government documents, drawings, and publications.	143
D.2.3	Non-Government publications.	144
D.2.4	Order of precedence.	144
D.3	REQUIRED EQUIPMENT AND MATERIALS	144
D.3.1	Required equipment and materials.	144
D.4	NOTES AND PROCEDURES	144
D.4.1	Dimensions.	144
D.4.2	Figures.	144
APPENDIX 5E – MIL-DTL-28840	CONNECTORS	156
E.1	SCOPE	156
E.1.1	Scope.	156
E.2	APPLICABLE DOCUMENTS	156
E.2.1	General.	156
E.2.2	Government documents.	156
E.2.2.1	Specifications, standards, and handbooks.	156
E.2.2.2	Other Government documents, drawings, and publications.	156
E.2.3	Non-Government publications.	157
E.2.4	Order of precedence.	157
E.3	REQUIRED EQUIPMENT AND MATERIALS	157
E.3.1	Required equipment and materials.	157

MIL-STD-2003-5B(SH)

E.4 NOTES AND PROCEDURES	157
E.4.1 Dimensions.....	157
E.4.2 Figures.....	157
APPENDIX 5F – MIL-DTL-27599 CONNECTORS	166
F.1 SCOPE	166
F.1.1 Scope.....	166
F.2 APPLICABLE DOCUMENTS	166
F.2.1 General.....	166
F.2.2 Government documents.....	166
F.2.2.1 Specifications, standards, and handbooks.....	166
F.2.2.2 Other Government documents, drawings, and publications.....	166
F.2.3 Non-Government publications.....	166
F.2.4 Order of precedence.....	166
F.3 REQUIRED EQUIPMENT AND MATERIALS.....	167
F.3.1 Required equipment and materials.....	167
F.4 NOTES AND PROCEDURES.....	167
F.4.1 Dimensions.....	167
F.4.2 Figures.....	167
APPENDIX 5G – MIL-DTL-22992 CONNECTORS.....	176
G.1 SCOPE.....	176
G.1.1 Scope.....	176
G.2 APPLICABLE DOCUMENTS	176
G.2.1 General.....	176
G.2.2 Government documents.....	176
G.2.2.1 Specifications, standards, and handbooks.....	176
G.2.2.2 Other Government documents, drawings, and publications.....	176
G.2.3 Non-Government publications.....	176
G.2.4 Order of precedence.....	176
G.3 REQUIRED EQUIPMENT AND MATERIALS	176
G.3.1 Required equipment and materials.....	176
G.4 NOTES AND PROCEDURES	176
G.4.1 Dimensions.....	176
G.4.2 Figures.....	177
APPENDIX 5H – MIL-DTL-38999 CONNECTORS.....	183
H.1 SCOPE.....	183
H.1.1 Scope.....	183
H.2 APPLICABLE DOCUMENTS	183
H.2.1 General.....	183
H.2.2 Government documents.....	183
H.2.2.1 Specifications, standards, and handbooks.....	183
H.2.2.2 Other Government documents, drawings, and publications.....	183
H.2.3 Non-Government publications.....	184
H.2.4 Order of precedence.....	184
H.3 REQUIRED EQUIPMENT AND MATERIALS	184
H.3.1 Required equipment and materials.....	184
H.4 NOTES AND PROCEDURES	184
H.4.1 Dimensions.....	184
H.4.2 Figures.....	184

MIL-STD-2003-5B(SH)

LIST OF TABLES

<u>TABLE</u>	<u>PAGE</u>
APPENDIX 5A – CABLE LEAD PREPARATION.....	5
TABLE 5AI. Figures for cable lead preparation.	8
TABLE 5A1-I. Approved solvents.	9
TABLE 5A2-I. Heat shrink tubing.	15
TABLE 5A2-II. Telescoping bushings.	17
TABLE 5A3-I. Rejection criteria for solder contacts.	26
TABLE 5A3-II. Cable lead stripping details.	27
TABLE 5A3-III. Ideal wire stripper part numbers.	30
TABLE 5A4-I. Wire barrel size.	34
TABLE 5A5-I. Soldering iron size.	35
TABLE 5A6-I. Cleaning solvents.	40
TABLE 5A6-II. Soldering iron size.	41
TABLE 5A7-I. Solder ferrule sizes.	52
TABLE 5A7-II. Shielded wire terminations: inner ferrule sizes.	56
TABLE 5A7-III. Shielded wire terminations: insulated outer ferrule sizes.	57
TABLE 5A10-I. Heat shrink tubing (SAE-AS23053).	74
TABLE 5A10-II. Approved solvents.	75
TABLE 5A11-I. Solvents.	79
APPENDIX 5B – MIL-C-81511/SAE-AS81511 SERIES 1 AND 2 GANG CONTACT RELEASE CONNECTOR ASSEMBLY PROCEDURE.....	92
TABLE 5BI. Figures for MIL-C-81511 or SAE-AS81511 connector assembly preparation.	94
TABLE 5B1-I. Wire barrel depths and minimum separation force.	99
TABLE 5B1-II. Crimp tooling information.	99
TABLE 5B1-III. Installation and removal tools.	100
TABLE 5B2-I. Wire barrel depths.	110
TABLE 5B2-II. Crimp tooling information.	111
TABLE 5B2-III. Installing and removal tools.	112
APPENDIX 5C – MIL-DTL-5015/SAE-AS50151 CONNECTORS.....	116
TABLE 5CI. Figures for MIL-DTL-5015/SAE-AS50151 connector assembly preparation.	118
TABLE 5C1-I. Wire barrel contact depth.	122
TABLE 5C2-I. Wire barrel contact depth.	128
TABLE 5C2-II. Front release.	129
TABLE 5C2-III. Rear release.	129
TABLE 5C2-IV. Tools for modified MIL-DTL-5015/SAE-AS50151 connectors.	130
TABLE 5C2-V. Bendix part numbers.	132
APPENDIX 5D – MIL-DTL-26482 CONNECTORS.....	143
TABLE 5DI. Figures for MIL-DTL-26482 connector assembly preparation.	144
TABLE 5D1-I. Wire barrel depth.	148
TABLE 5D1-II. Crimping tools for series 1 connectors.	149
TABLE 5D1-III. Crimping tools for series 2 connectors.	149
TABLE 5D1-IV. Insertion and removal tools.	150
TABLE 5D1-V. Insertion and removal tools.	152
APPENDIX 5E – MIL-DTL-28840 CONNECTORS.....	156
TABLE 5EI. Figures for MIL-DTL-28840 connector assembly preparation.	157
APPENDIX 5F – MIL-DTL-27599 CONNECTORS.....	166
TABLE 5FI. Figures for MIL-DTL-27599 connector assembly procedures.	167
TABLE 5F1-I. Contact wire barrel depths.	170
APPENDIX 5G – MIL-DTL-22992 CONNECTORS.....	176
TABLE 5GI. Figures for MIL-DTL-22992 connector assembly procedures.	177
TABLE 5G1-I. Contact wire barrel depths.	180
APPENDIX 5H – MIL-DTL-38999 CONNECTORS.....	183

MIL-STD-2003-5B(SH)

TABLE 5HI. Figures for MIL-DTL-38999 connector assembly procedures.	185
TABLE 5H1-I. Contact wire barrel depths.....	190
TABLE 5H1-II. Crimp tool guide.	191
TABLE 5H1-III. Installation and removal tools.....	192

MIL-STD-2003-5B(SH)

LIST OF FIGURES

<u>FIGURE</u>	<u>PAGE</u>
APPENDIX 5A – CABLE LEAD PREPARATION.....	5
FIGURE 5A1. Cable preparation procedures.....	9
FIGURE 5A2. Cable diameter change procedures.....	14
FIGURE 5A3. Individual lead stripping techniques.....	20
FIGURE 5A4. Connector contact crimping techniques.....	31
FIGURE 5A5. Tinning techniques.....	35
FIGURE 5A6. Conductor contact soldering techniques.....	40
FIGURE 5A7. Conductor shield termination procedures.....	51
FIGURE 5A8. Gross shield termination procedures.....	61
FIGURE 5A9. Connector lockwiring.....	68
FIGURE 5A10. Cable transflexing procedure.....	71
FIGURE 5A11. Cable bifurcation procedure.....	77
FIGURE 5A12. Glossary of terms.....	81
FIGURE 5A13. Tooling and materials list.....	84
FIGURE 5A14. Connector part number nomenclature.....	86
FIGURE 5A15. Water-proofing coaxial connectors.....	91
APPENDIX 5B – MIL-C-81511/SAE-AS81511 SERIES 1 AND 2 GANG CONTACT RELEASE CONNECTOR ASSEMBLY PROCEDURE.....	92
FIGURE 5B1. MIL-C-81511 or SAE-AS81511 series 1 and 2 gang contact release connector assembly procedure.....	95
FIGURE 5B2. MIL-C-81511 or SAE-AS81511 series 3 and 4 individual contact release connector assembly procedure.....	107
APPENDIX 5C – MIL-DTL-5015/SAE-AS50151 CONNECTORS.....	116
FIGURE 5C1. MIL-DTL-5015/SAE-AS50151 solder connector assembly procedure.....	119
FIGURE 5C2. MIL-DTL-5015/SAE-AS50151 (crimp) connector assembly procedure.....	124
FIGURE 5C3. Multi-cable connector assembly using grommets.....	137
APPENDIX 5D – MIL-DTL-26482 CONNECTORS.....	143
FIGURE 5D1. MIL-DTL-26482 connector assembly procedure.....	145
APPENDIX 5E – MIL-DTL-28840 CONNECTORS.....	156
FIGURE 5E1. MIL-DTL-28840 connector assembly procedure.....	158
APPENDIX 5F – MIL-DTL-27599 CONNECTORS.....	166
FIGURE 5F1. MIL-DTL-27599 connector assembly procedure.....	168
APPENDIX 5G – MIL-DTL-22992 CONNECTORS.....	176
FIGURE 5G1. MIL-DTL-22992 connector assembly procedure.....	178
APPENDIX 5H – MIL-DTL-38999 CONNECTORS.....	183
FIGURE 5H1. MIL-DTL-38999 connector assembly procedure.....	186

MIL-STD-2003-5B(SH)

1. SCOPE

1.1 Scope. This standard covers standard methods for connector fabrication on surface ships and submarines.

1.1.1 Application The installation methods in this document are intended to be used by all installing activities as required by contract, ship specifications, or similar implementing documents. These methods do not normally identify ship or type but do establish standards for connector installations in naval ships. The methods in this document are for new construction as well as for conversions, alterations, and repairs. It is the responsibility of the user activity to determine which method satisfies their requirements.

2. APPLICABLE DOCUMENTS

2.1 General. The documents listed in this section are specified in sections 3, 4, or 5 of this standard. This section does not include documents cited in other sections of this standard or recommended for additional information or as examples. While every effort has been made to ensure the completeness of this list, document users are cautioned that they must meet all specified requirements of documents cited in sections 3, 4, or 5 of this standard, whether or not they are listed.

2.2 Government documents.

2.2.1 Specifications, standards, and handbooks. The following specifications, standards, and handbooks form a part of this document to the extent specified herein. Unless otherwise specified, the issues of these documents are those cited in the solicitation or contract.

DEPARTMENT OF DEFENSE STANDARDS

MIL-STD-1310 - Shipboard Bonding, Grounding, and Other Techniques for Electromagnetic Compatibility, Electromagnetic Pulse (EMP) Mitigation, and Safety

(Copies of this document are available online at <https://quicksearch.dla.mil/>.)

2.2.2 Other Government documents, drawings, and publications. The following other Government documents, drawings, and publications form a part of this document to the extent specified herein. Unless otherwise specified, the issues of these documents are those cited in the solicitation or contract.

NAVAL SEA SYSTEMS COMMAND (NAVSEA) PUBLICATIONS

S9300-A6-GYD-010 - Electrical Workmanship Inspection Guide for Surface Ships and Submarines
 S9407-AB-HBK-010 - Handbook of Shipboard Electromagnetic Shielding Practices
 T9070-AL-DPC-020/077-2 - NAVSEA Hazardous Material Avoidance Process

(Copies of these documents are available online via Technical Data Management Information System (TDMIS) at <https://mercury.tdmis.navy.mil/>. Refer questions, inquiries, or problems to: DSN 296-0669, Commercial (805) 228-0669. This document is available for ordering (hard copy) via the Naval Logistics Library <https://nll.navsup.navy.mil/>. For questions regarding the NLL, contact the NLL Customer Service at nllhelpdesk@navy.mil, (866) 817-3130, or (215) 697-2626/DSN 442-2626.)

2.3 Non-Government publications. The following documents form a part of this document to the extent specified herein. Unless otherwise specified, the issues of these documents are those cited in the solicitation or contract.

SAE INTERNATIONAL

SAE-AIR6151 - Torque, Threaded Application, Electrical Connector, Accessory and Terminal Board Installation

(Copies of this document are available online at www.sae.org.)

MIL-STD-2003-5B(SH)

2.4 Order of precedence. Unless otherwise noted herein or in the contract, in the event of a conflict between the text of this document and the references cited herein, the text of this document takes precedence. Nothing in this document, however, supersedes applicable laws and regulations unless a specific exemption has been obtained.

3. DEFINITIONS

Refer to [figure 5A12](#).

4. GENERAL REQUIREMENTS

4.1 Instructions for use of MIL-STD-2003-5. This standard is designed to be utilized by a connector assembly technician and is formatted to be utilized as follows:

- a. Determine the governing specification for the connector being assembled.
- b. Proceed to the applicable Connector Assembly Procedure (figures in appendices 5B through 5H) and review to determine tools and materials required. Each appendix is designed to assemble a connector starting with the basic components and proceeding in a step-by-step manner to the completed assembly.
- c. Instructions shown on the figures in appendix 5A identify a sequence of processes common to any connector assembly (for example, lead stripping, crimping, soldering). The conduct of these procedures shall be sequenced by the Connector Assembly Procedures. The technician should review these procedures to become familiar with their content.
- d. Terminate the connector/backshell to the cable utilizing the appropriate Connector Assembly Procedure.
- e. The technician should keep in mind that to install a cable with connectors onboard a ship, in most instances, at least one end will need to be routed through a kickpipe, standpipe, stuffing tube, etc. and, thus, cannot have a connector installed prior to routing onboard the ship.

These procedures are designed for use with military specification connectors and backshells. Commercial substitutions may result in deviations from these procedures. Manufacturer assembly instructions should be consulted in these cases. Equal tooling and materials (see 4.2) may be substituted provided the intent of the specification is achieved.

4.2 Or equal. MIL-STD-2003 uses the terms “or equal” to permit the use of parts, components, or tools that are equivalent and can perform the same function as the specified products. The use of the equivalent product is allowed as long as the same functional characteristics, performance, equipment safety, personnel safety, suitability for marine service, life cycle cost, maintenance cost, and supportability are attained, and agreement is obtained from NAVSEA. The request for agreement for the use of “equal” products shall include data that supports that functional and performance equivalence is retained.

4.3 Consideration of electromagnetic shielding. For connector installations where electromagnetic shielding is required, or connectors need to be attached to cable conduit, the practices of S9407-AB-HBK-010 should be used. Connectors for EMI applications shall be installed to meet the requirements of MIL-STD-1310.

4.4 Use of connectors not covered in MIL-STD-2003-5. MIL-STD-2003-5 does not cover every type of connector installed in ship systems. For other connector types, such as RF, DB, Audio/Video, USB, and RJ connectors, class or specific ship installation drawings, provided by the ship design activity, or connector manufacturer’s instructions should be followed for connector installation. The general requirements of this document should be followed. The specific requirements in Appendix 5A should be followed to the maximum extent practicable. For installation of fiberoptic connectors, see MIL-STD-2042.

4.5 Connector post-installation retests. Pin pull tests, contact push tests, and torque-controlled screwdrivers and wrenches, which were required in the past, are no longer required. However, SAE-AIR6151 or connector manufacturer instructions may be consulted for guidance to determine the proper torque and tightness for assembling and installing electrical connectors.

MIL-STD-2003-5B(SH)

4.6 Inactive for new design documents. Some of the documents referenced in MIL-STD-2003-5 have been declared as inactive for new design by decision of the Department of Defense. Where replacement documents are designated, the replacement document is normally substituted for the inactive for new design document. Methods that reference inactive for new design documents shall not be used for new ship design unless approved by NAVSEA. Components and products produced in accordance with the inactive for new design documents shall not be used for new design of systems or equipment; however, this does not prohibit use for maintenance, repair, or resupply purposes. In addition, use of components is not prohibited in cases where connectors must interface with connectors being supplied with Government Furnished Equipment.

4.7 Workmanship and inspection guidance. For workmanship and inspection guidance associated with connector installation, see S9300-A6-GYD-010. For any conflict between this standard and S9300-A6-GYD-010, the requirements of this standard take precedence.

4.8 Hazardous materials. Materials and products utilized to execute installation methods in this standard should avoid chemicals listed on the NAVSEA List of Targeted Chemicals (N-LTC) contained within T9070-AL-DPC-020/077-2. These chemicals pose significant risk to the user, environment, or both, and are deemed both undesirable and unsustainable by NAVSEA. NAVSEA is minimizing the use of hazardous materials in procedures such as those covered by this standard. Alternative materials should be considered for applications covered in this document to minimize the use of targeted chemicals. NAVSEA should be informed of the need for the use of any of the targeted chemicals prior to procedure execution.

4.9 The terms agreement or approval. Wherever such terms as “approved” or “agreement” are used without further qualification, it is the approval or agreement of the Supervising Authority or NAVSEA, as applicable, that is intended. In these cases, the approval request and the response shall be formal, in writing, and traceable. Existing methods allowed by applicable ship specifications, such as departures from specifications, are acceptable. The Supervising Authority, also referred to as the Supervisor, is defined in the applicable ship specifications.

5. DETAILED REQUIREMENTS

(See figures.)

6. NOTES

(This section contains information of a general or explanatory nature that may be helpful, but is not mandatory.)

6.1 Intended use. This standard specifies the requirements for standard methods to be employed both on surface ships and submarines. Standard methods identified for electric plant installation are intended for new construction, conversion, and alteration of existing ships. The use of this standard will be specified in the contract, ship specifications, and similar implementing documents (such as COMUSFLTFORCOMINST 4790.3, Joint Fleet Maintenance Manual (JFMM) and S9086-KC-STM-010/300, Naval Ships' Technical Manual Chapter 300, Electric Plant-General).

6.2 Acquisition requirements. Acquisition documents should specify the following:

a. Title, number, and date of this standard.

6.3 Designation of electric plant installation standard methods figures. MIL-STD-2003-5 contains drawings that depict standard methods that are applicable for general electric plant installation on both surface ships and submarines. Each drawing has been assigned a figure number. The methods shown on the figures are grouped together in the following appendices to this standard. Each appendix provides requirements for similar functions.

- | | |
|-----------------------------|--|
| MIL-STD-2003-5 (Connectors) | <ul style="list-style-type: none"> A. Cable Lead Preparation (Appendix 5A) B. MIL-C-81511/SAE-AS81511 Series 1 and 2 Gang Contact Release Connector Assembly Procedure (Appendix 5B) C. MIL-DTL-5015/SAE-AS50151 Connectors (Appendix 5C) D. MIL-DTL-26482 Connectors (Appendix 5D) E. MIL-DTL-28840 Connectors (Appendix 5E) |
|-----------------------------|--|

MIL-STD-2003-5B(SH)

F. MIL-DTL-27599 Connectors (Appendix 5F)

G. MIL-DTL-22992 Connectors (Appendix 5G)

H. MIL-DTL-38999 Connectors (Appendix 5H)

The methods shown on the figures are identified by the following alphanumeric designation system:

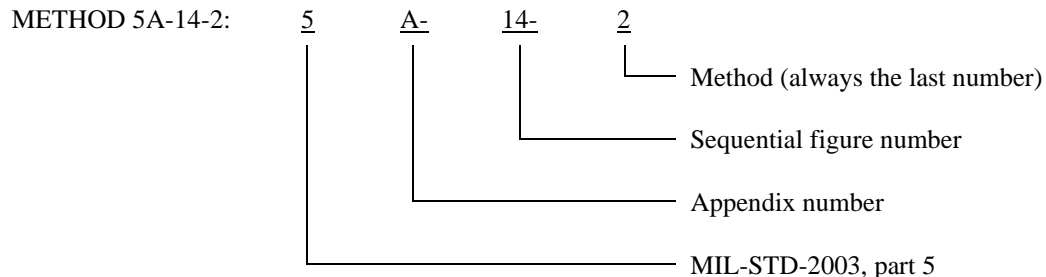

Thus, method 5A-14-2 identifies method 2, sequential number 14 in Appendix 5A of MIL-STD-2003-5.

6.4 Subject term (key word) listing.

Adapter
 Backshell
 Bifurcation
 Cable lead preparation
 Clamp
 Connector assembly
 Crimp
 Electromagnetic shielding
 Grommet
 Heat shrink
 Installation retest
 Lead strip
 Lockwire
 Pin
 Plug
 Shield termination
 Socket
 Solder
 Strain relief
 Strip
 Tinning
 Waterproof transflexing
 Wire barrel

6.5 Changes from previous issue. Marginal notations are not used in this revision to identify changes with respect to the previous issue due to the extent of the changes.

MIL-STD-2003-5B(SH)
APPENDIX 5A

APPENDIX 5A – CABLE LEAD PREPARATION

A.1 SCOPE

A.1.1 Scope. This appendix describes procedures for the preparation of leads for electrical connectors used aboard naval ships and submarines. This appendix is a mandatory part of the standard. The information contained herein is intended for compliance.

A.2 APPLICABLE DOCUMENTS

A.2.1 General. The documents listed in this section are specified in this appendix. This section does not include documents cited in other sections of this standard or recommended for additional information or as examples. While every effort has been made to ensure the completeness of this list, document users are cautioned that they must meet all specified requirements of documents cited in this appendix, whether or not they are listed.

A.2.2 Government documents.

A.2.2.1 Specifications, standards, and handbooks. The following specifications, standards, and handbooks form a part of this document to the extent specified herein. Unless otherwise specified, the issues of these documents are those cited in the solicitation or contract.

FEDERAL SPECIFICATIONS

- MMM-A-189 - Adhesive, Synthetic-Rubber, Thermoplastic, General-Purpose
- TT-I-735 - Isopropyl Alcohol

COMMERCIAL ITEM DESCRIPTIONS

- A-A-52506 - Clamps, Hose
- A-A-59770 - Insulation Tape, Electrical, Pressure Sensitive Adhesive and Pressure Sensitive Thermosetting Adhesive

DEPARTMENT OF DEFENSE SPECIFICATIONS

- MIL-DTL-915 - Cable, Electrical, for Shipboard Use, General Specification for
- MIL-DTL-22992 - Connectors, Plugs and Receptacles, Electrical, Waterproof, Quick Disconnect, Heavy Duty Type, General Specification for
- MIL-DTL-24640 - Cables, Lightweight, Low Smoke, Electric, for Shipboard Use, General Specification for
- MIL-DTL-24643 - Cables, Electric, Low Smoke Halogen-Free, for Shipboard Use, General Specification for
- MIL-DTL-26482 - Connectors, Electrical, Circular, Miniature, Quick Disconnect, Environment Resisting, Receptacles and Plugs, General Specification for
- MIL-DTL-27599 - Connectors, Electrical, Circular, Miniature, High Density, Quick Disconnect, Environment Resistant, Solder Contacts, General Specification for (see 4.6)
- MIL-DTL-28840 - Connectors, Electrical, Circular, Threaded, High Shock, High Density, Shipboard, Class D, General Specification for
- MIL-DTL-38999 - Connectors, Electrical, Circular, Miniature, High Density, Quick Disconnect (Bayonet, Threaded or Breech Coupling), Environment Resistant with Crimp Removable Contacts or Hermetically Sealed with Fixed, Solderable Contacts, General Specification for
- MIL-A-46146 - Adhesives-Sealants, Silicone, RTV, Noncorrosive (for Use with Sensitive Metals and Equipment)

MIL-STD-2003-5B(SH)
APPENDIX 5A

DEPARTMENT OF DEFENSE STANDARDS

- MIL-STD-1651 - Insert Arrangements for SAE-AS50151, MIL-DTL-22992 (Classes C, J and R), MIL-DTL-83723 (Series II), and SAE-AS95234 Circular Electrical Connectors
- MIL-STD-1669 - Insert Arrangements for MIL-DTL-26482 Environment Resisting, Circular Electrical Connectors
- MIL-STD-1698 - Insert Arrangements for MIL-DTL-28840 High Density High Shock Circular Electrical Connectors

(Copies of these documents are available online at <https://quicksearch.dla.mil>.)

A.2.2.2 Other Government documents, drawings, and publications. The following other Government documents, drawings, and publications form a part of this document to the extent specified herein. Unless otherwise specified, the issues of these documents are those cited in the solicitation or contract.

MILITARY SPECIFICATION SHEETS

- MS3116 - Connectors, Plug, Electrical, Solder Type, Straight, Bayonet Coupling, Series 1, Classes E, F, J and P (see 4.6)
- MS17344 - Connector, Plug, Electrical, Straight
- MS20028 - Connectors, Plug, Electrical, Straight, Solder Type, Bayonet Coupling, Class T, Series I (see 4.6)
- MS27467 - Connectors, Plug, Electrical, Straight, Crimp Type, Bayonet Coupling, Series I

(Copies of these documents are available online at <https://quicksearch.dla.mil>.)

A.2.3 Non-Government publications. The following documents form a part of this document to the extent specified herein. Unless otherwise specified, the issues of these documents are those cited in the solicitation or contract.

ASTM INTERNATIONAL

- ASTM B286 - Standard Specification for Copper Conductors for Use in Hookup Wire for Electronic Equipment
- ASTM D1193 - Standard Specification for Reagent Water
- ASTM D4376 - Standard Specification for Vapor-Degreasing Grade Perchloroethylene

(Copies of these documents are available online at www.astm.org.)

IPC

- J-STD-004 - Requirements for Soldering Fluxes
- J-STD-005 - Requirements for Soldering Pastes
- J-STD-006 - Requirements for Electronic Grade Solder Alloys and Fluxed and Non-Fluxed Solid Solders for Electronic Soldering Applications

(Copies of these documents are available online at www.ipc.org.)

NATIONAL AEROSPACE STANDARDS COMMITTEE (NA/NAS)

- NASM20995 - Wire, Safety or Lock

(Copies of this document are available online at www.aia-aerospace.org.)

MIL-STD-2003-5B(SH)
APPENDIX 5A

SAE INTERNATIONAL

- SAE-AS5942 - Marking of Electrical Insulating Materials
- SAE-AS18121 - Ferrules, Outer, Insulated, Shield Terminating, Type II Two-Piece, Class I, for Shielded Cable
- SAE-AS21608 - Ferrule, Shield Terminating, Crimp Style
- SAE-AS21981 - Ferrule, Inner, Uninsulated, Shield Terminating, Type I, Two Piece, Class I, for Shielded Cables
- SAE-AS22520 - Crimping Tools, Wire Termination, General Specification for
- SAE-AS22520/5 - Crimping Tools, Type 2, Terminal, Hand, Wire Termination, for Coaxial, Twinaxial, Triaxial, Shielded Contacts and Ferrules, Terminal Lugs, Splices and End Caps
- SAE-AS22520/6 - Crimping Tools, Terminal, Hand, Wire Termination; In-Service Inspection Gages for Type II AS22520/5, /10, and MIL-T-22520/32 (Cancel) Crimp Tools
- SAE-AS22520/10 - Crimping Tools, Type 2, Terminal, Hand, Wire Termination, for Coaxial, Twinaxial, Triaxial, Shielded Contacts and Ferrules, Terminal Lugs, Splices, and End Caps
- SAE-AS23053 - Insulation Sleeving, Electrical, Heat Shrinkable, General Specification for
- SAE-AS23053/5 - Insulation Sleeving, Electrical, Heat Shrinkable, Polyolefin, Flexible, Crosslinked
- SAE-AS23053/15 - Insulation Sleeving, Electrical, Heat Shrinkable, Polyolefin, Heavy-Wall, Coated, Flexible, Outer Wall Crosslinked
- SAE-AS81765/1 - Insulating Components, Molded, Electrical, Heat Shrinkable Polyolefin, Crosslinked, Semi-Rigid and Flexible
- SAE-AS83519 - Shield Termination, Solder Style, Insulated, Heat-Shrinkable, Environment Resistant General Specification for
- SAE-AS85049 - Connector Accessories, Electrical General Specification For
- SAE-AS85049/1 - Connector Accessories, Electrical, Backshell, Environmental, Cable Sealing, Straight, Grounding (Without Strain Relief), Category 1C (for AS50151 Solder Type, V Thread of AS310XX Classes A, B, C, or K Connectors, AS95234 Connectors)
- SAE-AS85049/2 - Connector Accessories, Electrical, Backshell, Environmental, Cable Sealing, Straight, Category 1C (for AS50151 Solder Type, V Thread of AS310XX Classes A, B, C, or K Connectors, AS95234 Connectors)
- SAE-AS85049/41 - Connector Accessories, Electrical, Non-Environmental, Strain Relief, Straight, Category 4C (for AS50151 Solder Type, V Thread of MS310X, Classes A, B, C, or K Connectors and AS85049 Accessories)
- SAE-AS85049/42 - Connector Accessories, Electrical, Nonenvironmental, Strain Relief, Straight, Category 4A (for AS50151 Solder Type, V Thread of MS310X Classes A, B, C or K Connectors)

(Copies of these documents are available online at www.sae.org.)

MIL-STD-2003-5B(SH)
APPENDIX 5A

A.2.4 Order of precedence. Unless otherwise noted herein or in the contract, in the event of a conflict between the text of this document and the references cited herein, the text of this document takes precedence. Nothing in this document, however, supersedes applicable laws and regulations unless a specific exemption has been obtained.

A.3 REQUIRED EQUIPMENT AND MATERIALS

A.3.1 Required equipment and materials. The required equipment and materials are specified in the standard methods of this section.

A.4 NOTES AND PROCEDURES

A.4.1 Dimensions. For figures and tables in this appendix, all dimensions are in inches unless otherwise noted.

A.4.2 Figures. [Table 5AI](#) provides information for the figures in this appendix.

TABLE 5AI. Figures for cable lead preparation.

Figure number	Cable lead preparation	Page
5A1	Cable preparation procedures	9
5A2	Cable diameter change procedures	14
5A3	Individual lead stripping techniques	20
5A4	Connector contact crimping techniques	31
5A5	Tinning techniques	35
5A6	Conductor contact soldering techniques	40
5A7	Conductor shield termination procedures	51
5A8	Gross shield termination procedures	61
5A9	Connector lockwiring	68
5A10	Cable transflexing procedure	71
5A11	Cable bifurcation procedure	77
5A12	Glossary of terms	81
5A13	Tooling and materials list	84
5A14	Connector part number nomenclature	86
5A15	Water-proofing coaxial connectors	91

MIL-STD-2003-5B(SH)
APPENDIX 5A

Cable preparation procedures:

1. Ensure the cable is the correct type as specified on the applicable cabling diagram.
2. Measure the cable to the required length.
 - a. When the connector is prefabricated in the shop, add 5' or 5 percent, whichever is greater.
 - b. When measuring the cable to terminate at equipment onboard, ensure that sufficient length exists to allow for at least one, but where practicable, three re-terminations of the connector contacts. Ensure that the required cable bend radius is maintained.
3. Visually inspect the cable jacket for deformities, cuts, or punctures.
4. Wipe the cable jacket or armor, if present, with an approved solvent from [table 5A1-I](#) in order to remove grease, oil, dirt, and other debris in the area where the connector and backshell will be installed.

TABLE 5A1-I. Approved solvents.

Solvent	Specification
Isopropyl alcohol	TT-I-735
Perchloroethylene	ASTM D4376
Reagent water (type II)	ASTM D1193
Detergent cleaners	As approved by the Government procuring activity

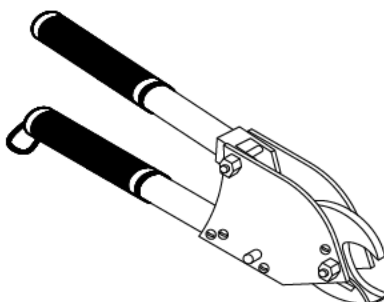

ILLUSTRATION 1
CABLE SHEARS

5. Cut the cable perpendicular to the cable axis utilizing cable shears (H.K. Porter Company 6990FS, or equal [see 4.2, illustration 1]). Ensure a clean sharp cut, all conductors are the same length, and there is no damage to the cable.
6. Verify cable diameter is compatible with cable clamp size.
 - a. Place the clamp assembly over the outermost cable covering and tighten (see 4.5) the clamp screws securely to ensure a minimum gap of $\frac{1}{16}$ inch is maintained between clamp saddles and support (see illustration 2). If satisfactory clamping cannot be obtained, build up or reduce cable diameter in accordance with [figure 5A2](#). The minimum $\frac{1}{16}$ -inch gap requirement applies to all connectors covered by Appendices 5B-5H of this standard. For other connectors, there shall be a discernable gap between the clamp saddles to prevent metal-to-metal contact. All saddle clamp assemblies shall be of sufficient tightness to prevent the cable, harness, or individual wire material from moving and to eliminate strain on the wire/connector terminations.

FIGURE 5A1. Cable preparation procedures.

MIL-STD-2003-5B(SH)
APPENDIX 5A

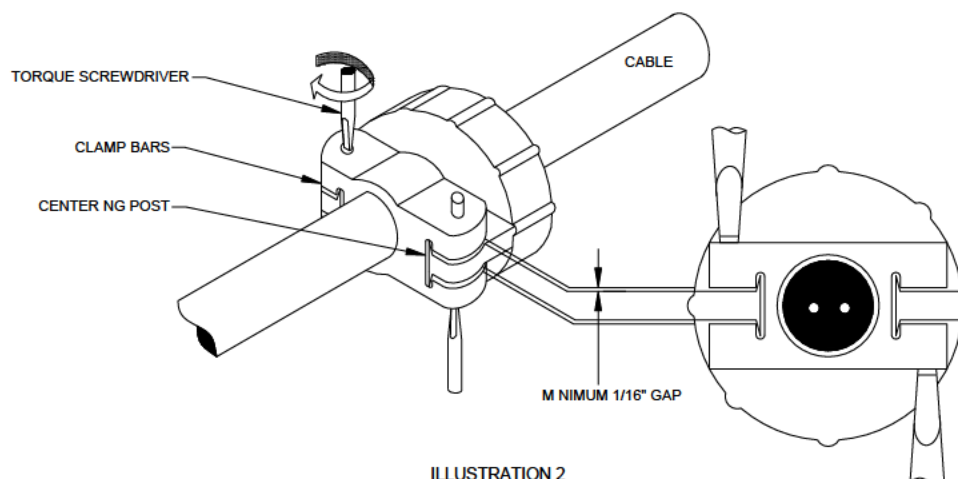

ILLUSTRATION 2

NOTE: For armored cable, prepare the cable using steps 7 through 15. For unarmored cable, prepare the cable using steps 8 through 15.

Cable preparation procedures (continued):

7. Armor preparation, if present:

CAUTION: Do not damage the cable jacket beneath the armor.

a. Backshell without armor clinching RFI ferrules (PC 6 and 7).

- (1) Measure the length of the assembled backshell (PC 2 through 9) from the connector end to the front end of the clamp saddle (PC 9) (see illustration 3).

NOTE: On angled backshells, measure the center radius dimension.

- (2) Add 2 inches and mark this dimension on the armor. Cut and remove the cable armor at this mark using a cable stripper (see illustration 4).

FIGURE 5A1. Cable preparation procedures – Continued.

MIL-STD-2033-5B(SH)
APPENDIX 5A

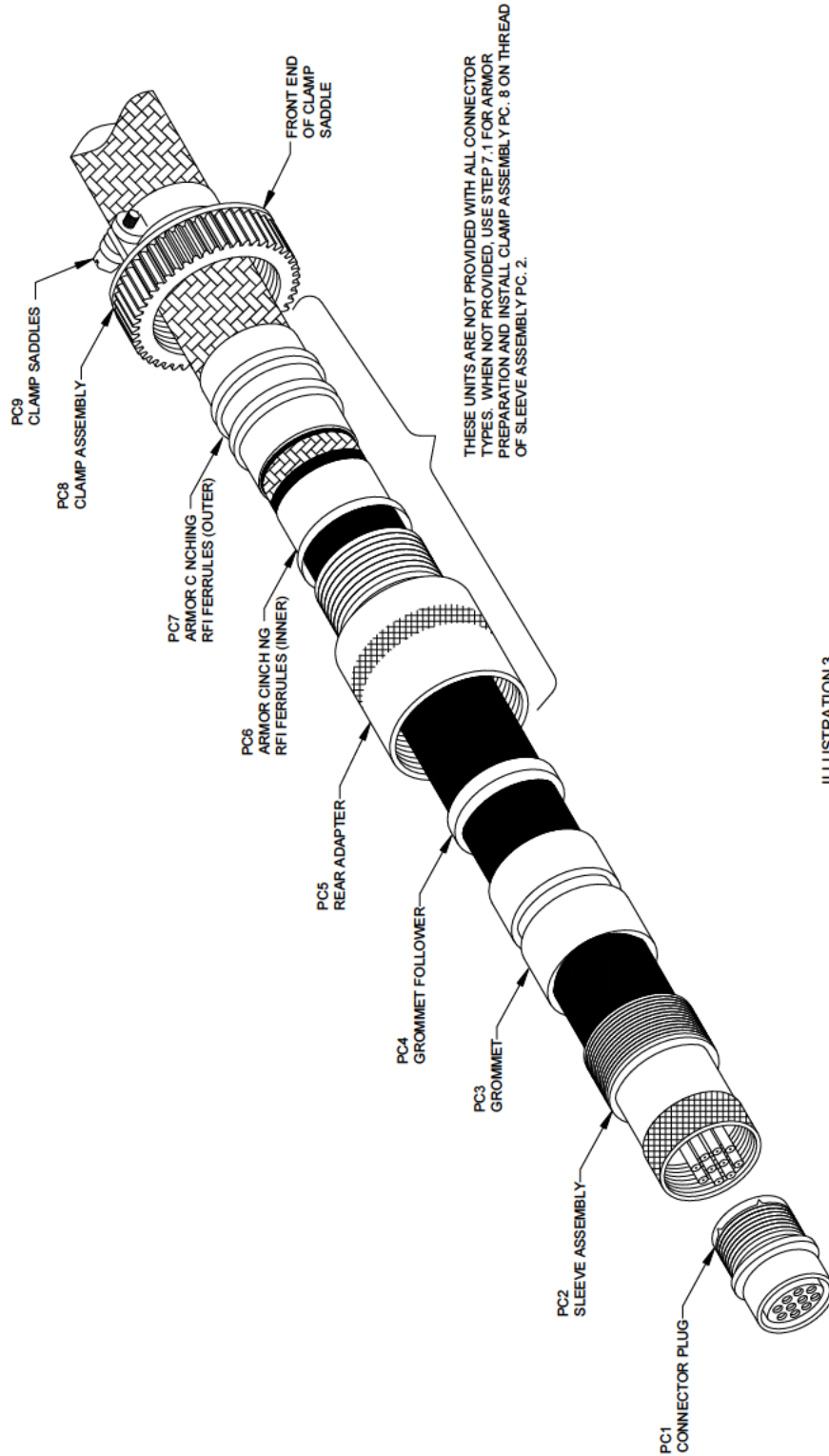

ILLUSTRATION 3
TYPICAL CONNECTOR ASSEMBLY

FIGURE 5A1. Cable preparation procedures— Continued.

MIL-STD-2003-5B(SH)
APPENDIX 5A

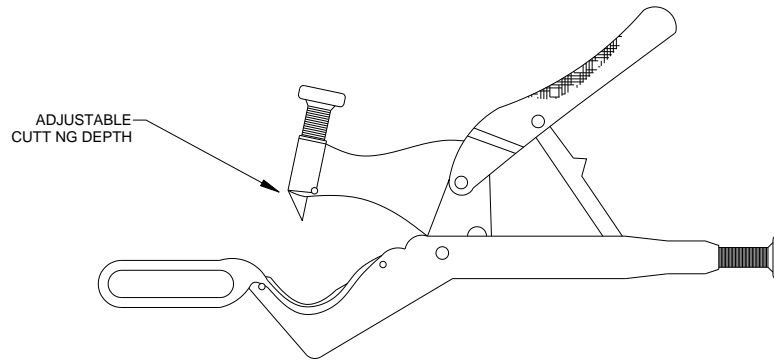
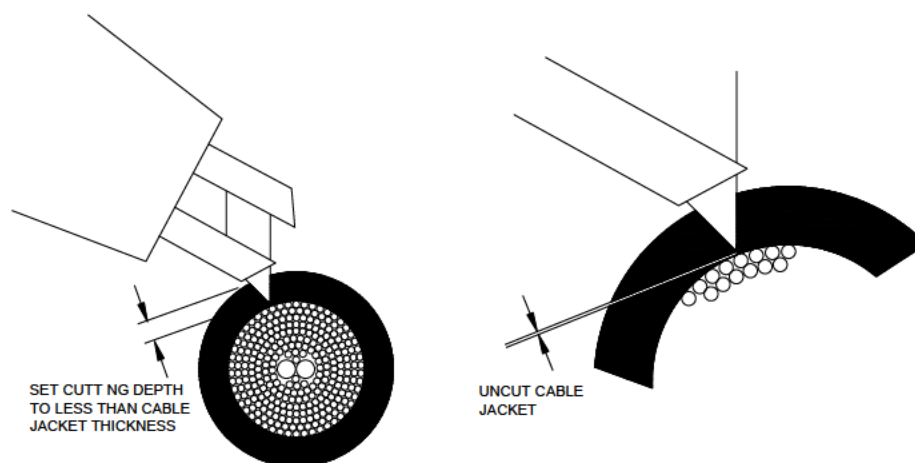

ILLUSTRATION 4
CABLE STRIPPER

Cable preparation procedures (continued):

- (3) Center a $\frac{3}{4}$ -inch to 1-inch length of appropriately sized heat shrink tubing meeting the requirements of SAE-AS23053/5, class 1 over the armor termination point and shrink in place using a heat gun, prior to tightening the saddle clamps.
- b. Backshell with armor clinching ferrules.
 - (1) Measure the length of the assembled backshell (PC 2 through 6) from the connector end to the inner armor clinching RFI ferrule (PC 6) (see illustration 3).
NOTE: On angled backshells, measure the center radius dimension.
 - (2) Add 2 inches and mark this dimension on the armor. Cut and remove the cable armor at this mark using a cable stripper.
CAUTION: Do not damage the cable jacket beneath the armor.
8. Verify cable diameter is compatible with grommet size for environmental seal.
 - a. Wipe the cable jacket with an approved solvent from [table 5A1-I](#) in order to remove grease, oil, dirt, and other debris.
 - b. Assemble, in correct order and orientation, the required backshell hardware to compress the grommet to the PVC jacket.
NOTE: Tighten without bottoming of adjoining assemblies (see 4.5).
 - c. Attempt to push backshell straight along cable, applying moderate pressure (do not twist); backshell shall not move. If satisfactory sealing cannot be obtained, build up or reduce the cable diameter in accordance with [figure 5A2](#).
 - d. Remove all backshell components from the cable.
9. Jacket preparation for environmental sealing.
 - a. Measure the length of the assembled backshell from the connector end to the nearest grommet end (PC 3, illustration 3).
 - b. Add 2 inches and mark this dimension on the jacket.
 - c. Disassemble and relocate the backshell and clamp components on the cable. Verify that all parts are included and are in correct order and orientation. Assemble the backshell and locate it on the cable so that it will not interfere with connector wiring.
 - d. Remove the cable jacket to the predetermined length as follows:
NOTE: Ensure the cut does not penetrate the jacket completely (see illustration 5).

FIGURE 5A1. Cable preparation procedures – Continued.

MIL-STD-2003-5B(SH)
APPENDIX 5AILLUSTRATION 5
SCORE CABLE JACKET**Cable preparation procedures (continued):**

- (1) Score the circumference of the jacket with a multi-purpose cutter (OLFA 300, or equal [see 4.2]) at the mark made in step 9.a.
 - (2) Score the jacket piece to be removed along its length with a multi-purpose cutter.
 - (3) Remove the jacket piece utilizing needle nose pliers.
10. Prepare gross shield in accordance with [figure 5A8](#), if applicable.
 11. Cut and remove any glass belt, tape, fillers, or core used in the cable construction as close to the jacket as possible.
 12. Prepare individual conductor shields in accordance with [figure 5A7](#), if applicable.
 13. Inspect the individual conductors to ensure the insulation is not cut, nicked, or scratched and that none of the conductors are crushed.
 14. Prepare twisted pairs or triads as follows (if applicable):
 - a. For military specification cables identified with the standard identification code, each triad or twisted pair should be identified by placing a ¼-inch length of pre-marked shrink tubing over each triad or pair and shrinking in place.
 - b. For military specification cables identified with the telephone identification code, each twisted pair should be identified by placing a ⅛-inch piece of insulated sleeving over each twisted pair.
NOTE: Do not use adhesive backed markers.
 - c. The tubing should be located close to the cable jacket end and staggered so as to prevent formation of a bulky lump.
 15. Identify the individual leads as follows (not required if conductor size or backshell/clamp shape, size, or configuration prevents installation):
 - a. Slide pre-marked electrical insulating sleeving, which meets the requirements of SAE-AS23053/5, class 1, length and size to suit, over each conductor.
 - (1) The sleeves shall be marked with the contact letter or number of the contact position to which they are connected in accordance with SAE-AS5942.

FIGURE 5A1. Cable preparation procedures – Continued.

MIL-STD-2003-5B(SH)
APPENDIX 5A

Method 5A-2-1
Cable diameter build-up procedures

Procedure:

1. These procedures shall be used when the cable entrance dimension of the backshell is too large for the cable diameter to which the connector backshell assembly is being attached.
2. The material used for cable build-up shall extend completely through the sealing grommet without interruption at completion of connector assembly.
3. The first method depicts the use of heat shrink sleeving as the means to increase the cable diameter. The second method depicts the use of telescoping bushings as the means of cable diameter build-up. Each method is designed such that it can be used individually or in combination with the other as the method for cable build-up.

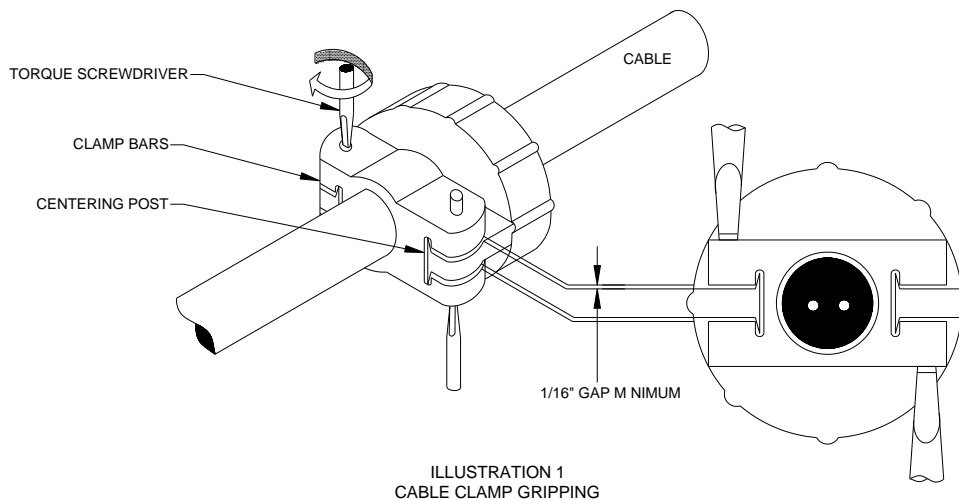

4. The following method shall be used in conjunction with heat shrink sleeving. The cable diameter build-up shall not exceed the maximum cable entryway diameter (cable range) of the clamp.
 - a. Build up the cable jacket in the vicinity of the environmental seal or cable clamp or both as follows:
 - (1) Measure the installed length of the grommet, grommet follower, and cable clamp.
 - (2) Cut a correctly sized piece of heat shrinkable tubing meeting the requirements of SAE-AS23053/5, class 1 to a length equal to that measured in step 4.a(1).
 - (a) The size of the heat shrink tubing shall be selected from [table 5A2-I](#) such that the inner diameter after shrinkage shall be less than the cable diameter.

FIGURE 5A2. Cable diameter change procedures.

MIL-STD-2003-5B(SH)
APPENDIX 5A

TABLE 5A2-I. Heat shrink tubing.

Military part number	I.D. min. (as supplied)	After unrestricted shrinkage	
		I.D. max.	Wall thickness
Class 1			
M23053/5-101	0.046	0.023	0.016±0.003
102	0.063	0.031	0.017±0.003
103	0.093	0.046	0.020±0.003
104	0.125	0.062	0.020±0.003
105	0.187	0.093	0.020±0.003
106	0.250	0.125	0.025±0.003
107	0.375	0.187	0.025±0.003
108	0.500	0.250	0.025±0.003
109	0.750	0.375	0.030±0.003
110	1.000	0.500	0.035±0.005
111	1.500	0.750	0.040±0.006
112	2.000	1.000	0.045±0.007
113	3.000	1.500	0.050±0.008
114	4.000	2.000	0.055±0.009
Class 1 over expanded			
M23053/5-115	1.000	0.275	0.045±0.005
116	2.000	0.550	0.045±0.005
117	3.000	0.810	0.045±0.005
118	4.000	1.050	0.045±0.005
119	1.000	0.462	0.045±0.005
120	2.375	0.680	0.045±0.005
121	3.000	0.840	0.045±0.005
122	3.750	0.930	0.045±0.005
123	4.500	1.450	0.045±0.005

Cable diameter build-up procedures (continued):

- (3) Install the heat shrink tubing on the cable in the area where the environmental seal and cable clamp will be, and shrink in place using a heat gun.
 - (4) Verify that satisfactory environmental sealing can be obtained without bottoming of adjoining backshell assemblies.
 - (5) Verify that the clamp securely holds over the sleeving and cable, maintaining a minimum gap of $\frac{1}{16}$ inch between clamp saddles and support (see illustration 1). The minimum $\frac{1}{16}$ -inch gap requirement applies to all connectors covered by Appendices 5B-5H of this standard. For other connectors, there shall be a discernable gap between the clamp saddles to prevent metal-to-metal contact. All saddle clamp assemblies shall be of sufficient tightness to prevent the cable, harness, or individual wire material from moving and to eliminate strain on the wire/connector terminations.
 - (6) Continue applying heat shrink tubing until the cable outside diameter is compatible with the cable sealing range of the environmental grommet, cable clamp, or both.
5. [Table 5A2-II](#) provides detailed information on the SAE-AS85049 telescoping bushing. The following method shall be used in conjunction with an SAE-AS85049 telescoping bushing (see illustration 2).

FIGURE 5A2. Cable diameter change procedures – Continued.

MIL-STD-2003-5B(SH)
APPENDIX 5A

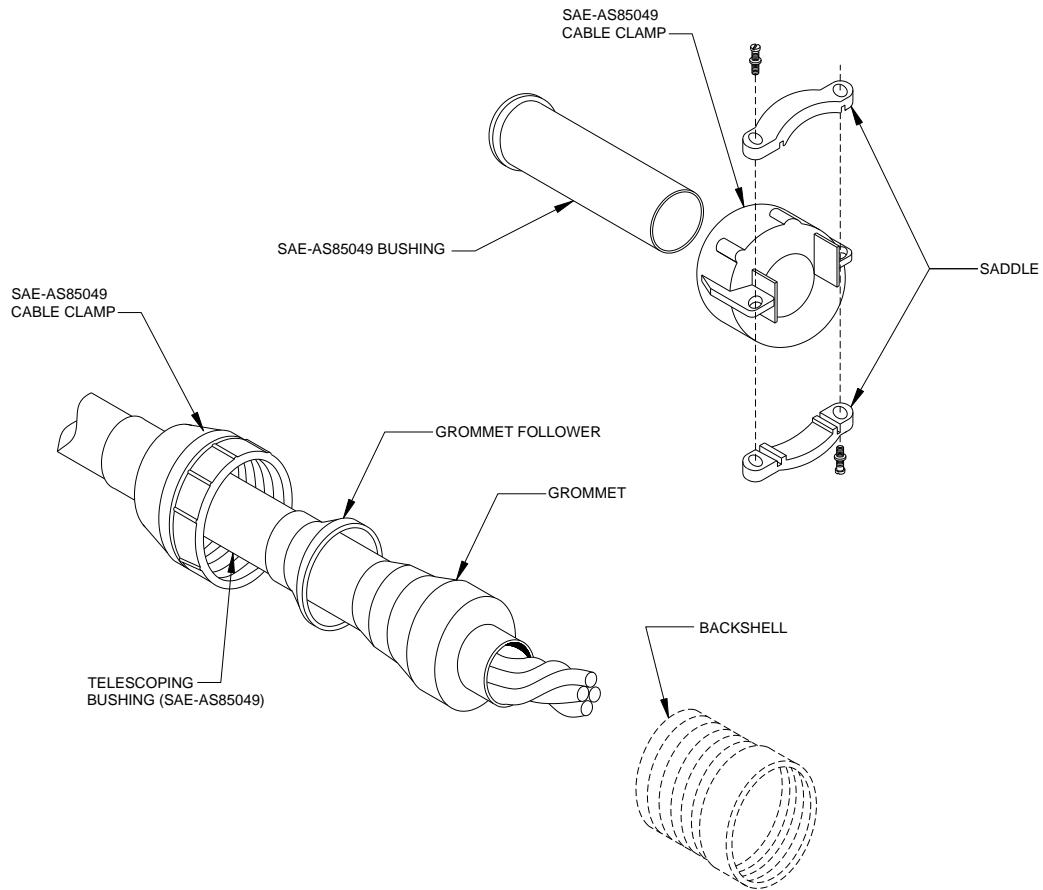

ILLUSTRATION 2
INSTALLING SAE-AS85049 TELESCOPING BUSHING

NOTE: The SAE-AS85049 bushing shall not be installed under the grommet. The SAE-AS85049 bushings are only used to build up cable diameter under the cable clamp. References to SAE-AS85049 specifically refer to specification sheets SAE-AS85049/1, SAE-AS85049/2, SAE-AS85049/41, and SAE-AS85049/42 for particular components of the connector.

FIGURE 5A2. Cable diameter change procedures – Continued.

MIL-STD-2003-5B(SH)
APPENDIX 5A

TABLE 5A2-II. Telescoping bushings.

SAE-AS85049 dash number	A diameter	B diameter	C diameter	D length
-3	0.130	0.210	0.379	2.875
-4	0.220	0.302	0.505	2.750
-6	0.312	0.427	0.619	2.625
-8	0.437	0.552	0.744	2.500
-10	0.562	0.615	0.889	2.375
-12	0.625	0.740	1.084	2.250
-16	0.750	0.927	1.314	2.125
-20	0.937	1.240	1.598	2.000
-24	1.250	1.365	1.847	1.875
-28	1.375	1.614	2.085	1.750
-32	1.624	1.864	2.335	1.625
-40	1.874	2.364	2.835	1.500

Cable diameter build-up procedures (continued):

- a. Measure the installed length of the grommet, grommet follower, and cable clamp. If measured length is longer than available bushing, use heat shrink tubing to build up cable diameter.

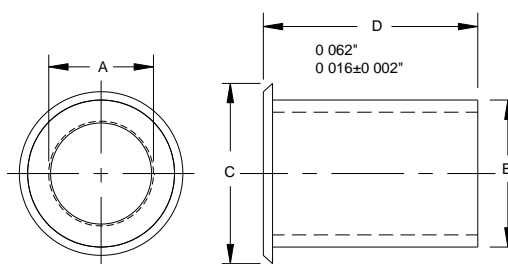
ILLUSTRATION 3
SAE-AS85049

- b. Slide a correctly sized SAE-AS85049 telescoping bushing (see illustration 3) on the conductor bundle.
(1) [Table 5A2-II](#) provides information on the SAE-AS85049 telescoping bushing in order to select the proper size based on the cable diameter.

FIGURE 5A2. Cable diameter change procedures – Continued.

MIL-STD-2003-5B(SH)
APPENDIX 5A

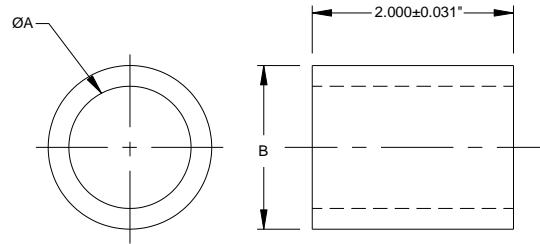

ILLUSTRATION 4
SAE-AS85049 BUSHING

Cable diameter build-up procedures (continued):

- (2) Verify that satisfactory environmental sealing can be obtained without bottoming of adjoining backshell assemblies.
- (3) Verify that the cable clamp securely holds over the bushing and cable maintaining a minimum gap of $\frac{1}{16}$ inch between clamp saddles and support (see illustration 1). The minimum $\frac{1}{16}$ -inch gap requirement applies to all connectors covered by Appendices 5B-5H of this standard. For other connectors, there shall be a discernable gap between the clamp saddles to prevent metal-to-metal contact. All saddle clamp assemblies shall be of sufficient tightness to prevent the cable, harness, or individual wire material from moving and to eliminate strain on the wire/connector terminations.

NOTE: More than one bushing may be used to achieve the desired cable diameter (see illustration 5). However, the cable diameter build-up shall not exceed the maximum cable entryway diameter (cable range) of the clamp.

NOTE: Two design bushings are available. The one has an outside end flange (see illustration 3) while the other has no flange (see illustration 4).

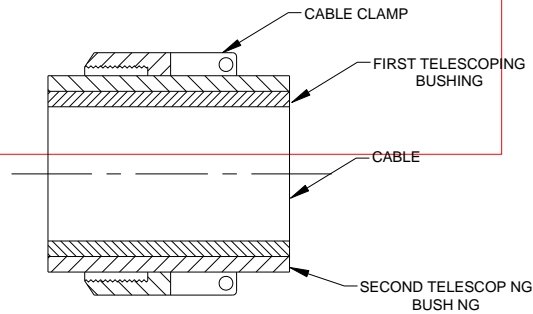

ILLUSTRATION 5
USING MORE THAN ONE TELESCOPING BUSHING

FIGURE 5A2. Cable diameter change procedures – Continued.

MIL-STD-2003-5B(SH)
APPENDIX 5A

Method 5A-2-2
Reducing cable diameter for entry into a connector

General notes:

1. This method includes instructions for reducing a cable diameter for entry into a connector. Only use this method if the cable jacket diameter is too large for the connector to achieve proper strain relief.
2. Heat shrink tubing is required to replace the cable jacket inside a connector to achieve optimal strain relief for the cable and connector.
3. Continually apply layers of heat shrink tubing, as shown in the following illustration, until the diameter of the heat shrink tubing correctly matches the required diameter of the connector strain relief. Ensure that the heat shrink extends past the strain relief location and covers the end of the cable jacket. The heat shrink shall extend past the environmental seal inside of the backshell if backshell contains an environmental seal.

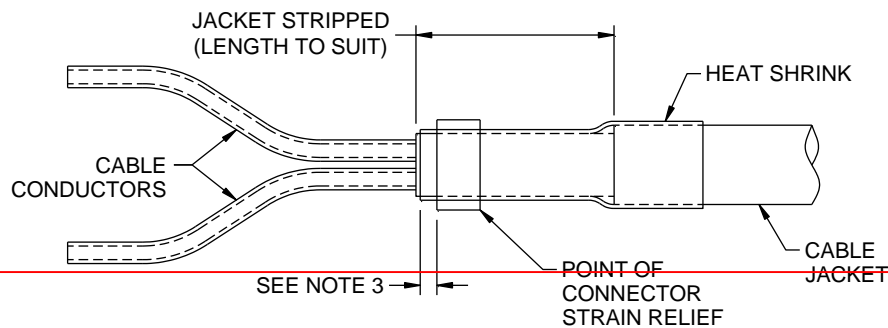

TYPICAL APPLICATION OF HEAT SHRINK

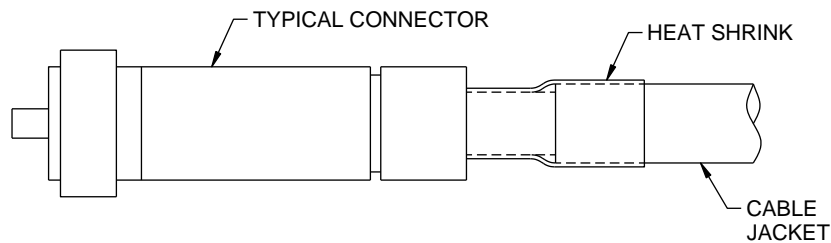

TYPICAL VIEW ILLUSTRATING COMPLETED CABLE AND CONNECTOR

FIGURE 5A2. Cable diameter change procedures – Continued.

MIL-STD-2003-5B(SH)
APPENDIX 5A**Individual lead stripping techniques:**

1. Thermal stripping is the preferred method when compatible with the insulation type.
2. The following precautions shall be observed when stripping wires with either thermal or mechanical strippers:
 - a. Ensure the blades or heated stripping elements of thermal strippers are kept clean at all times.
 - b. Ensure all stripping blades are sharp and free from nicks, dents, and any other mechanical deformities that may prevent proper operation.
 - c. Ensure the correct stripping hole is used for the corresponding wire size. Illustration 8 of [figure 5A3](#) is provided to show construction of a common conductor.
CAUTION: There are significant differences between Navy and commercial (AWG) wire gauges. Ensure all comparisons are taken using the same convention.
 - d. When stripping the lead, hold the wire perpendicular to the cutting or thermal blade (see illustration 2 and illustration 7 on [figure 5A3](#) for examples).
 - e. Avoid nicking, cutting, or otherwise damaging the wire strands.
 - f. Ensure there are no frayed or ragged edges after the insulation has been removed.
 - g. Ensure all insulation has been removed from the stripped area.
 - h. Conductor strands may be re-twisted if required to restore the natural lay and tightness of the strands. Avoid bare finger contact with the wire strands.
3. Glass braid or tape and synthetic rubber shall be removed utilizing precision mechanical strippers in accordance with step 6.
4. Strip individual lead using thermal or mechanical stripping method (step 5 or 6). [Table 5A3-II](#) contains conductor information for common Navy cables (MIL-DTL-24643) and the recommended stripping method. Note that [table 5A3-II](#) is not a comprehensive list of cables where conductor stripping will be necessary to attach a conductor to a connector contact. For cables not covered in [table 5A3-II](#), consult specification sheets or cable manufacturer's information. (For information on low smoke cables, refer to MIL-DTL-24643 and MIL-DTL-24640. For information on non-low smoke cable, refer to MIL-DTL-915.)
 - a. Strippers shall be tested and adjusted on a test conductor prior to stripping actual cable conductor.
 - b. Avoid nicking, cutting, or damaging wire strands during stripping.
 - c. Take care to prevent small particles, especially those which are conductive, from entering into connector contact cavities. Particles may hamper proper seating of contacts and cause short circuits.

FIGURE 5A3. Individual lead stripping techniques.

MIL-STD-2003-5B(SH)
APPENDIX 5A

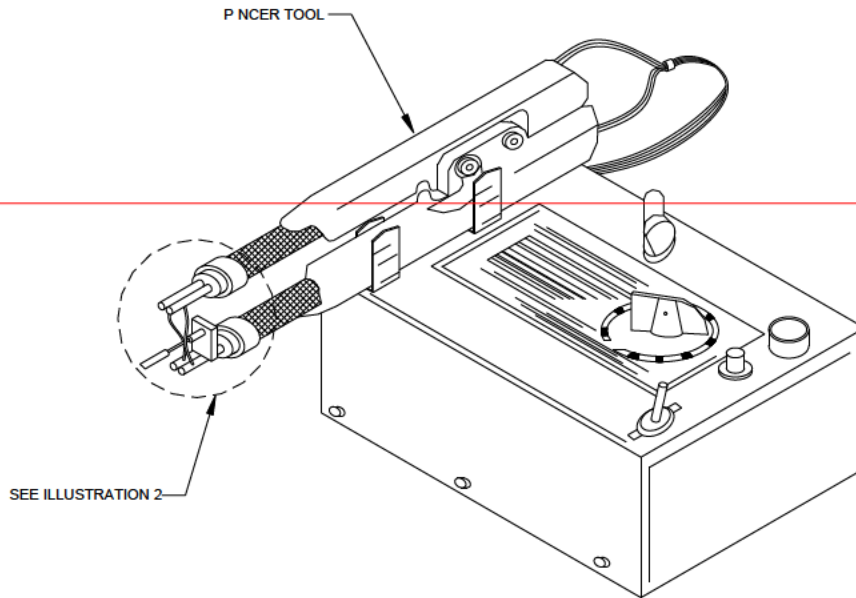

ILLUSTRATION 1
THERMAL STRIPPER

Individual lead stripping techniques (continued):

5. Thermal stripper (see illustration 1).
 - a. When required for personnel safety, an exhaust hood and fan ventilation system shall be used to exhaust toxic fumes from polytetrafluoroethylene or polyvinyl chloride.
 - b. Observe the following when using thermal wire strippers:
 - (1) Determine the insulation material using [table 5A3-II](#) as guidance.
 - (2) Employ the lowest temperature setting that will give satisfactory results.
 - (3) Minimize the time heat is applied for stripping in order to minimize insulation damage and safety hazards due to melting. At no time should the insulation decomposition temperature be utilized.
 - (4) Assure the adequacy of exhaust ventilation.
 - c. Ensure the stripper is obtained using NSN 5130-00-996-9389. Adjust the wire stripper for the depth of the contact wire barrel specified for the type of connector being assembled plus the allowable insulation clearance specified in step 7 (see illustration 2).

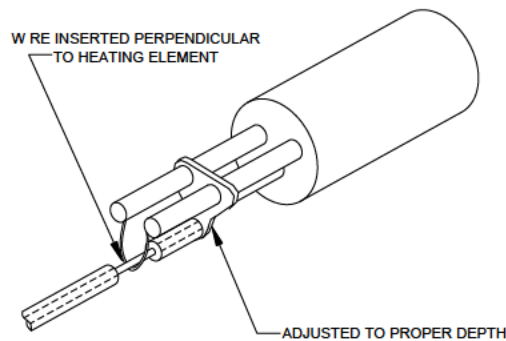

ILLUSTRATION 2
THERMAL STRIPPER DEPTH ADJUSTMENT

FIGURE 5A3. Individual lead stripping techniques – Continued.

MIL-STD-2003-5B(SH)
APPENDIX 5A

Individual lead stripping techniques (continued):

- d. Adjust the temperature to the insulation melting temperature listed in [table 5A3-II](#) for the specific cable type being stripped. If a temperature is not listed, use a precision mechanical stripper in accordance with step 6.
 - e. Check strip length on several test pieces. Strip length should meet criteria of insulation clearance (see step 7). Adjust strip length as necessary.
 - f. Insert the conductor to be stripped between the heating elements or stripper blades.
 - g. Twist the tool slightly or rotate the wire to ring the insulation while applying heat (see illustration 1).
 - h. Draw the wire from the tool. The insulation slug shall be removed with the heating elements.
6. Precision mechanical stripper (see illustration 3).
 - a. Ensure stripper is a precision fixed die cutting type (see illustration 3 for an example of a satisfactory stripper). Strippers that permit operator adjustment shall not be used (see illustration 4).
 - (1) Select the correct stripper blade for the size conductor being stripped utilizing data supplied by the manufacturer. [Table 5A3-III](#) is provided as an example of typical Ideal stripper models.

FIGURE 5A3. Individual lead stripping techniques – Continued.

MIL-STD-2003-5B(SH)
APPENDIX 5A

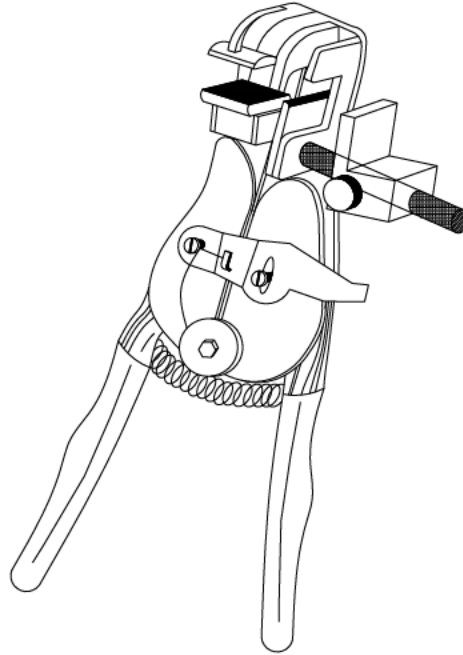

ILLUSTRATION 3
PRECISION MECHANICAL STRIPPER

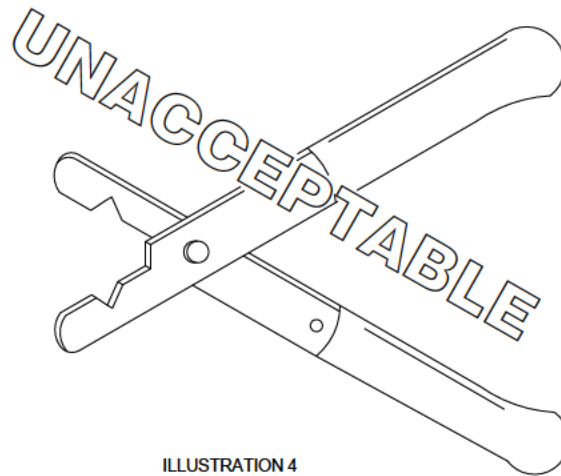

ILLUSTRATION 4
UNACCEPTABLE WIRE STRIPPER

FIGURE 5A3. Individual lead stripping techniques – Continued.

MIL-STD-2003-5B(SH)
APPENDIX 5A

Individual lead stripping techniques (continued):

- b. Examine the stripper to ensure the blades line up for proper operation (see illustration 5).

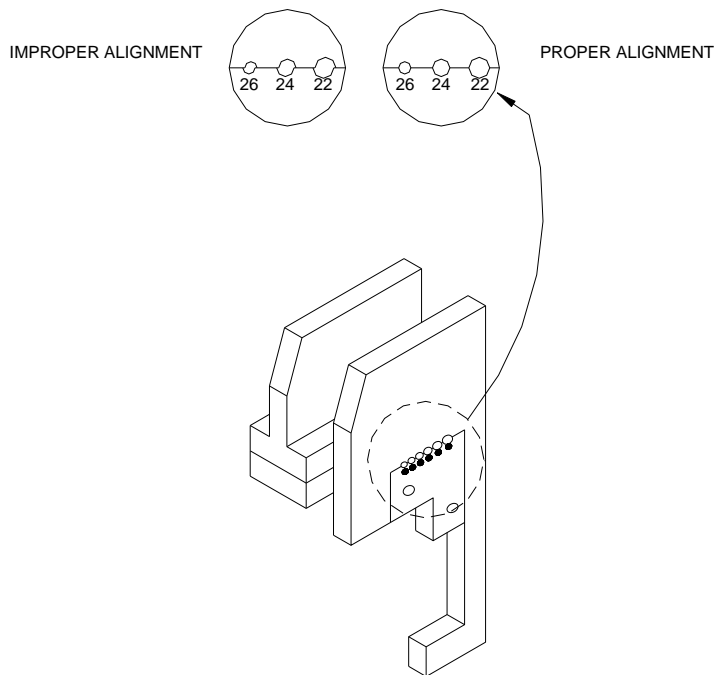
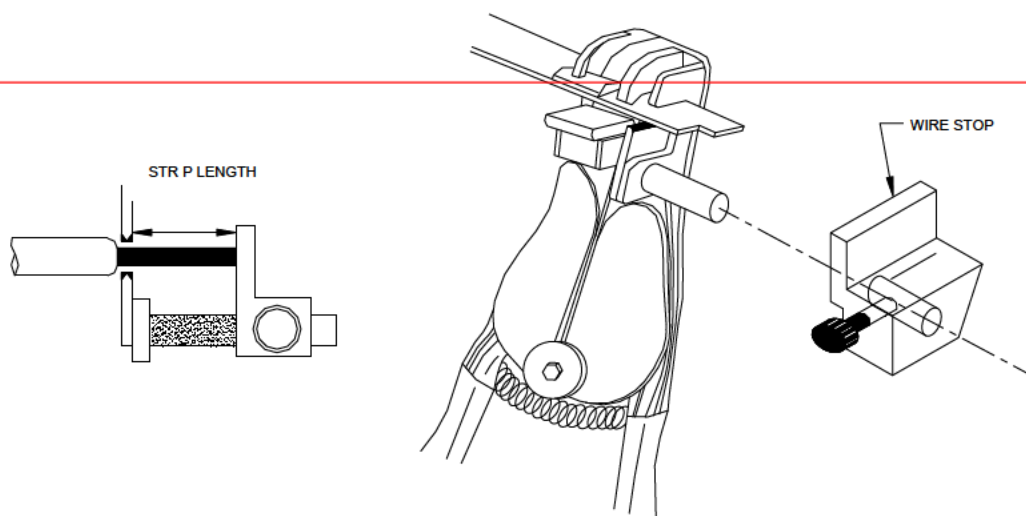

ILLUSTRATION 5
STRIPPING BLADE ALIGNMENT

- c. Set the wire stop for the depth of the contact wire barrel as specified in the connector assembly procedure for the connector type being assembled, plus the allowable insulation clearance specified in step 7 (see illustration 6).
- d. Check strip length on several test pieces.
- (1) Strip length shall meet the criteria of insulation clearance (see step 7). Adjust strip length as necessary.
 - (2) Ensure correct stripping hole is used for corresponding conductor gauge. See [table 5A3-II](#) for conductor size.
- e. Position the conductor in the stripper jaws (see illustration 7).
- f. Squeeze the handles.

FIGURE 5A3. Individual lead stripping techniques – Continued.

MIL-STD-2003-5B(SH)
APPENDIX 5AILLUSTRATION 6
MECHANICAL STRIPPER DEPTH ADJUSTMENT**Individual lead stripping techniques (continued):**

7. Examine the stripped wire for insulation damage and proper insulation clearance. Wires with damaged insulation shall not be used.
 - a. Crimp contact insulation clearance specification.
 - (1) Conductor shall be bottomed in contact wire barrel.
 - (2) Conductor shall be visible in inspection hole.
 - (3) Conductor shall only be visible to a maximum of $\frac{1}{2}$ inch (20 gauge and smaller) or $\frac{1}{16}$ inch (18 gauge and larger) at rear of contact.
 - (4) Contour of the conductor shall be visible at the insulation gap.

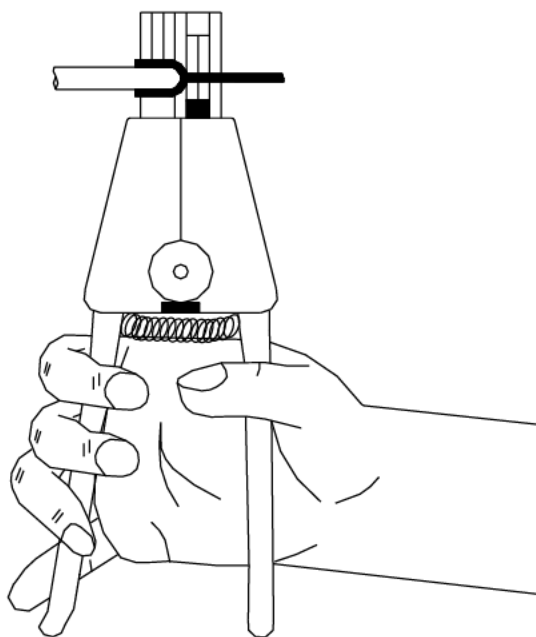
ILLUSTRATION 7
CONDUCTOR POSITIONED IN STRIPPERFIGURE 5A3. Individual lead stripping techniques – Continued.

MIL-STD-2003-5B(SH)
APPENDIX 5A

Individual lead stripping techniques (continued):

- b. Solder contact insulation clearance specification.
 - (1) Conductor shall be bottomed in contact wire barrel.
 - (2) Minimum clearance: Insulation shall not be imbedded in the solder joint.
 - (3) Contour of the conductor shall be visible at the insulation gap.
 - (4) Maximum clearance: Less than two wire diameters including insulation or $\frac{1}{16}$ inch, whichever is larger, but shall not permit shorting between adjacent conductors.
8. Examine the wire with a magnifying glass (6X to 10X power) to ensure the strands have not been scratched, nicked, cut, scraped, broken, or otherwise damaged.
 - a. See [table 5A3-I](#) for rejection criteria for solder contacts.

TABLE 5A3-I. Rejection criteria for solder contacts.

Number of strands	Maximum allowable nicked or broken strands
Less than 7	0
7-15	1
16-18	2
19-25	3
26-36	4
37-40	5
41 or more	6

- b. For crimped contacts, no conductor strand damage is acceptable.

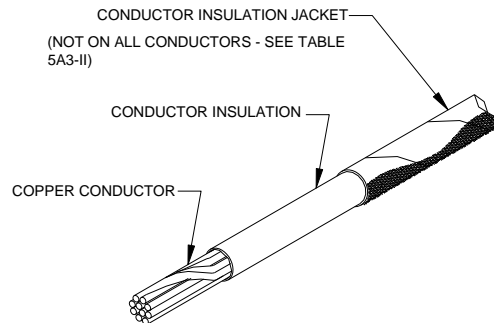

ILLUSTRATION 8
TYPICAL CONDUCTOR CONSTRUCTION
(SEE TABLE 5A3-II)

9. Rework rejected conductors as follows:
 - a. Cut the conductor square where the damage ends.
 - b. Re-strip the conductor in accordance with step 4.

FIGURE 5A3. Individual lead stripping techniques – Continued.

MIL-STD-2003-5B(SH)
APPENDIX 5A

TABLE 5A3-II. Cable lead stripping details.

Cable type ^{2.3}	Conductor wire material	Size of wire conductor	No. of strands per conductor	Max. wire diameter	Max. conductor diameter	Conductor primary insulation material	Insulation melting temp.	Insulation decomposition temp.	Conductor insulation jacket material	Insulation jacket melting temp.	Insulation jacket decomposition temp.	Recommended stripping method
LSDHOF-3	Copper, uncoated	2½(26) (Navy standard)	26	0.061	0.123	Separator ^{1/}	Undetermined ^{1/}	Undetermined ^{1/}	Synthetic rubber	248 F	248 F	Mechanical
LSDHOF-4	Copper, uncoated	4(41)	41	0.077	0.139	Separator ^{1/}	Undetermined ^{1/}	Undetermined ^{1/}	Synthetic rubber	248 F	248 F	Mechanical
LSDHOF-6	Copper, uncoated	6(65) (Navy standard)	65	0.097	0.159	Separator ^{1/}	Undetermined ^{1/}	Undetermined ^{1/}	Synthetic rubber	248 F	248 F	Mechanical
LSDSGU-3	Copper, uncoated	3(7) (Navy standard)	7	0.060	0.130	Extruded silicone rubber	482 F	530 F	Glass braid	1300 F	--	Mechanical
LSDSGU-4	Copper, uncoated	4(7) (Navy standard)	7	0.076	0.143	Extruded silicone rubber	482 F	530 F	Glass braid	1300 F	--	Mechanical
LSDSGU-50	Copper, uncoated	50(19) (Navy standard)	19	0.254	0.334	Silicone rubber	482 F	530 F	Glass tape	1300 F	--	Mechanical
LSFHOF-4	Copper, uncoated	4(41) (Navy standard)	41	0.077	0.139	Separator ^{1/}	Undetermined ^{1/}	Undetermined	Synthetic rubber	248 F	248 F	Mechanical
LSFHOF-9	Copper, uncoated	9(90) (Navy standard)	90	0.120	0.182	Separator ^{1/}	Undetermined ^{1/}	Undetermined ^{1/}	Synthetic rubber	248 F	248 F	Mechanical
LSFSGU-3	Copper, uncoated	3(7) (Navy standard)	7	0.060	0.096	Extruded silicone rubber	482 F	530 F	Glass braid	1300 F	--	Mechanical
LSFSGU-4	Copper, uncoated	4(7) (Navy standard)	7	0.076	0.112	Extruded silicone rubber	482 F	530 F	Glass braid	1300 F	--	Mechanical
LSFSGU-9	Copper, uncoated	9(7) (Navy standard)	7	0.108	0.154	Extruded silicone rubber	482 F	530 F	Glass braid	1300 F	--	Mechanical
LSFSGU-23	Copper, uncoated	23(7) (Navy standard)	7	0.171	0.316	Extruded silicone rubber	482 F	530 F	Glass braid	1300 F	--	Mechanical
LSFSGU-50	Copper, uncoated	50(19) (Navy standard)	19	0.254	0.334	Silicone rubber	482 F	530 F	Glass tape	1300 F	--	Mechanical
LSMCOS-2	Copper, uncoated	1½(16) (Navy standard)	16	0.049	0.072	Separator ^{1/}	Undetermined	Undetermined	Cross linked polyethylene or synthetic rubber	--	--	Mechanical
LSMCOS-6	Copper, uncoated	1(10) (Navy standard)	10	0.038	0.064	Separator ^{1/}	Undetermined	Undetermined	Cross linked polyethylene or synthetic rubber	--	--	Mechanical
LSTTOP-XX	Copper, uncoated	1(10) (Navy standard)	10	0.038	0.078	Separator ^{1/}	Undetermined	Undetermined	Cross linked polyethylene or synthetic rubber	--	--	Mechanical
LSTTRS-XX	Copper, uncoated	1(7) (Navy standard)	7	0.038	0.078	Separator ^{1/}	Undetermined	Undetermined	Cross linked polyethylene or synthetic rubber	--	--	Mechanical

FIGURE 5A3. Individual lead stripping techniques – Continued.

MIL-STD-2003-5B(SH)
APPENDIX 5ATABLE 5A3-II. Lead stripping details – Continued.

Cable type ^{2,3,4}	Conductor wire material	Size of wire conductor	No. of strands per conductor	Max. wire diameter	Max. conductor diameter	Conductor primary insulation material	Insulation melting temp.	Insulation decomposition temp.	Conductor insulation jacket material	Insulation jacket melting temp.	Insulation jacket decomposition temp.	Recommended stripping method
LSTTSU-XX	Copper, uncoated	3/5(7) (Navy standard)	7	0.030	0.047	Extruded silicone rubber	482 F	530 F	Polyamide	325-450 F	700 F	Thermal
LS1SMWU-70	Copper, tin-coated	22-7 ASTM B286	7	0.033	0.093	Separator ^{1/}	Undetermined	Undetermined	Cross linked polyethylene or synthetic rubber	--	--	Mechanical
LS1S50MU-70	Copper, tin-coated	22-7 ASTM B286	7	0.033	0.093	Separator ^{1/}	Undetermined	Undetermined	Cross linked polyethylene or synthetic rubber	--	--	Mechanical
LS2SJ-16	Copper, tin-coated	16-19 ASTM B286	19	0.062	0.091	Separator ^{1/}	Undetermined	Undetermined	Cross linked polyethylene or synthetic rubber	--	--	Mechanical
LS2SJ-20	Copper, tin-coated	20-19 ASTM B286	19	0.038	0.073	Separator ^{1/}	Undetermined	Undetermined	Cross linked polyethylene or synthetic rubber	--	--	Mechanical
LS2SU-XX	Copper, uncoated	22-7 ASTM B286	7	0.033	0.059	Separator ^{1/}	Undetermined	Undetermined	Cross linked polyethylene or synthetic rubber	--	--	Mechanical
LS2SWAU-XX	Copper, uncoated	22-7 ASTM B286	7	0.033	0.059	Separator ^{1/}	Undetermined	Undetermined	Cross linked polyethylene or synthetic rubber	--	--	Mechanical
LS2U-XX	Copper, tin-coated	26-7 ASTM B286	7	0.020	0.051	Separator ^{1/}	Undetermined	Undetermined	Cross linked polyethylene or synthetic rubber	--	--	Mechanical
LS3SJ-12	Copper, uncoated	6(7) (Navy standard)	7	0.092	0.145	Separator ^{1/}	Undetermined	Undetermined	Cross linked polyethylene or synthetic rubber	--	--	Mechanical
LS3SJ-14	Copper, tin-coated	14-19 ASTM B286	19	0.072	0.105	Separator ^{1/}	Undetermined	Undetermined	Cross linked polyethylene or synthetic rubber	--	--	Mechanical
LS3SJ-16	Copper, tin-coated	16-19 ASTM B286	19	0.062	0.091	Separator ^{1/}	Undetermined	Undetermined	Cross linked polyethylene or synthetic rubber	--	--	Mechanical
LS3SJ-18	Copper, tin-coated	18-19 ASTM B286	19	0.051	0.084	Separator ^{1/}	Undetermined	Undetermined	Cross linked polyethylene or synthetic rubber	--	--	Mechanical
LS3SU-XX	Copper, uncoated	18 (AWG)	7	0.050	0.096	Polyethylene	275-400 F	440 F	Polyamide	325-450 F	700 F	Thermal
LS7SGU-3	Copper, uncoated	3(7) (Navy standard)	7	0.060	0.130	Extruded silicone rubber	482 F	530 F	Glass braid	1300 F	--	Mechanical
LS7SGU-4	Copper, uncoated	4(7) (Navy standard)	7	0.076	0.143	Extruded silicone rubber	482 F	530 F	Glass braid	1300 F	--	Mechanical
LSTMHOF-XX	Copper, uncoated	2½(19) (Navy standard)	19	0.057	0.097	Separator ^{1/}	Undetermined	Undetermined	Cross linked polyethylene or synthetic rubber	--	--	Mechanical

FIGURE 5A3. Individual lead stripping techniques – Continued.

MIL-STD-2003-5B(SH)
APPENDIX 5ATABLE 5A3-II. Lead stripping details – Continued.

Cable type ^{2,3/}	Conductor wire material	Size of wire conductor	No. of strands per conductor	Max. wire diameter	Max. conductor diameter	Conductor primary insulation material	Insulation melting temp.	Insulation decomposition temp.	Conductor insulation jacket material	Insulation jacket melting temp.	Insulation jacket decomposition temp.	Recommended stripping method
LSMSCU-XX	Copper, uncoated	2(7) (Navy standard)	7	0.048	0.084	Extruded silicone rubber	482 F	530 F	Glass braid	1300 F	--	Mechanical
LSRG-108A/U	Copper, tin-coated	20 (AWG)	7	0.038	0.079	Polyethylene	275-400 F	440 F	None	--	--	Thermal
LSSHOF-3	Copper, uncoated	2½(65) (Navy standard)	65	0.061	0.123	Separator ^{1/}	Undetermined ^{1/}	Undetermined ^{1/}	Synthetic rubber	248 F	248 F	Mechanical
LSSSGU-50	Copper, uncoated	50(19) (Navy standard)	19	0.254	0.334	Silicone rubber	482 F	530 F	Glass tape	1300 F	--	Mechanical
LSTHOF-3	Copper, uncoated	2½(26) (Navy standard)	26	0.061	0.123	Separator ^{1/}	Undetermined ^{1/}	Undetermined ^{1/}	Synthetic rubber	248 F	248 F	Mechanical
LSTHOF-9	Copper, uncoated	9(90) (Navy standard)	90	0.120	0.182	Separator ^{1/}	Undetermined ^{1/}	Undetermined ^{1/}	Synthetic rubber	248 F	248 F	Mechanical
LSTHOF-14	Copper, uncoated	14(140) (Navy standard)	140	0.145	0.225	Separator ^{1/}	Undetermined ^{1/}	Undetermined ^{1/}	Synthetic rubber	248 F	248 F	Mechanical
LSTSGU-3	Copper, uncoated	3(7) (Navy standard)	7	0.060	0.130	Extruded silicone rubber	482 F	530 F	Glass braid	1300 F	--	Mechanical
LSTSGU-4	Copper, uncoated	4(7) (Navy standard)	7		0.143	Extruded silicone rubber	482 F	530 F	Glass braid	1300 F	--	Mechanical
LSTSGU-9	Copper, uncoated	9(7) (Navy standard)	7	0.108	0.187	Extruded silicone rubber	482 F	530 F	Glass braid	1300 F	--	Mechanical
LSTSGU-14	Copper, uncoated	14(7) (Navy standard)	7	0.136	0.230	Extruded silicone rubber	482 F	530 F	Glass braid	1300 F	--	Mechanical
LSTSGU-23	Copper, uncoated	23(7) (Navy standard)	7	0.171	0.284	Extruded silicone rubber	482 F	530 F	Glass braid	1300 F	--	Mechanical
LSTSGU-150	Copper, uncoated	150(61) (Navy standard)	61	0.451	0.557	Silicone rubber	482 F	530 F	Glass tape	1300 F	--	Mechanical

NOTES:

^{1/} Several types of wires are manufactured with a layer between the conductor and the insulation jacket called the separator. The separator may consist of various materials, such as glass fibers, synthetic fibers, synthetic fiber tape, polyester tape, etc. Ensure the separator is removed along with the insulation.

^{2/} In most instances, when manufactured in the watertight version, the letter W is added to the cable designation.

^{3/} Not all cable types where lead stripping is necessary are covered in this table. For cables not covered in this table, see step 4.

FIGURE 5A3. Individual lead stripping techniques – Continued.

MIL-STD-2003-5B(SH)
APPENDIX 5A

TABLE 5A3-III. Ideal wire stripper part numbers.

Ideal cat. no.	Blade only	Blade hole size										
		10	12	14	16	18	20	22	24	26	28	30
45-169	L-9300 cutter dia. counterbore dia.								0.024 0.033	0.018 0.025	0.014 0.023	0.012 0.019
45-170 45-180	L-5210 cutter dia. counterbore dia.	0.116 0.154	0.0937 0.135	0.076 0.113								
45-171 45-181	L-5211 cutter dia. counterbore dia.				0.062 0.096	0.052 0.086	0.042 0.073	0.035 0.0635	0.0292 0.0595	0.022 0.052		
45-172 45-182	L-5436 cutter dia. counterbore dia.									0.024 0.043	0.020 0.040	0.016 0.037
45-173 45-183	L-5562 cutter dia. counterbore dia.	0.119 0.144	0.095 0.125	0.076 0.104								
45-174 45-184	L-5563 cutter dia. counterbore dia.				0.061 0.089	0.052 0.0785	0.042 0.057	0.034 0.0595	0.028 0.055	0.023 0.0485		
45-175 45-185	L-5564 cutter dia. counterbore dia.									0.023 0.0465	0.019 0.043	0.016 0.042
45-176 45-186	L-5559 cutter dia. counterbore dia.	0.119 0.136	0.096 0.113	0.076 0.0938								
45-177 45-187	L-5560 cutter dia. counterbore dia.				0.061 0.081	0.052 0.070	0.042 0.0595	0.034 0.052	0.028 0.043	0.023 0.039		
45-178 45-188	L-5561 cutter dia. counterbore dia.									0.023 0.039	0.019 0.035	0.016 0.032
45-179	L-7625 cutter dia. counterbore dia.											0.012 0.020

FIGURE 5A3. Individual lead stripping techniques – Continued.

MIL-STD-2003-5B(SH)
APPENDIX 5A

Connector contact crimping techniques:

1. Observe the following when crimping contacts:
 - a. Ensure the crimping tool is calibrated in accordance with SAE-AS22520.
 - b. The crimping tool and positioner shall conform to SAE-AS22520.
2. Select the crimping tool (see illustration 4) and positioner in accordance with those specified for the connector being assembled.
3. Check the crimping tool for proper operation as follows:
 - a. Check proper action of tool.
 - (1) Squeeze handles together.
 - (2) Check (ensure that) locking mechanism (ratchet) releases when handles are fully closed.
 - (3) Release the handles.
 - b. Check proper action of crimpers.
 - (1) Select correct inspection gauge ("GO"/"NO-GO" gauge) for crimping tool in accordance with SAE-AS22520 or instruction sheet provided with crimping tool.
 - (2) Rotate selector knob to correct position for testing in accordance with SAE-AS22520 or crimper instruction sheet.
 - (3) Activate the tool to the fully closed position and hold. The "GO" gauge shall be freely inserted in the space between opposing closed indentors. Release pressure on the handles and allow the tool to open automatically.
 - (4) Activate the tool to the fully closed position and hold. The "NO-GO" gauge shall not be insertable between opposing indentors.
4. Mount the positioner on the crimping tool in accordance with the appropriate instructions for the tool being used.

NOTE: Do not crimp the gauge. It will damage the indentors.
5. Mount the positioner on the crimping tool in accordance with the appropriate instructions for the tool being used.

NOTE: The tool handles shall be fully open when inserting the positioner or changing the selector setting.
6. Set the wire size selector knob for the wire size being crimped. The correct wire size selector number is determined from the chart on the side of the turret head.
7. Insert the stripped wire into the contact. The stripped wire shall be visible in the inspection hole and at the rear of the contact wire barrel (maximum gap between contact and insulation depends on contact size) (see illustration 1).
 - a. ~~Ensure all wire strands are inserted into the contact wire barrel.~~

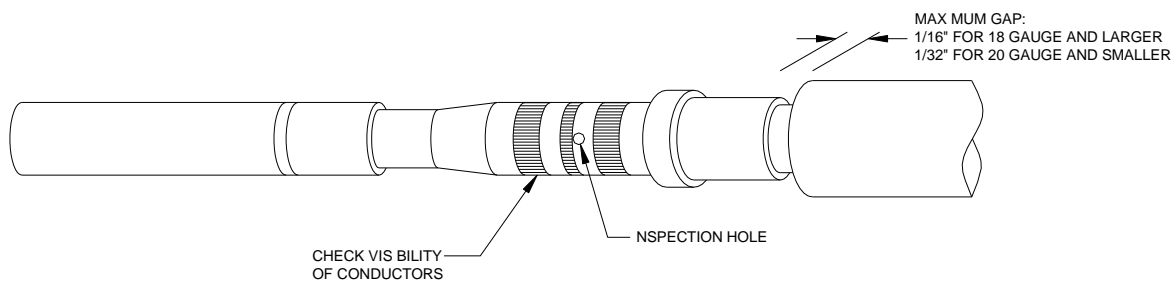
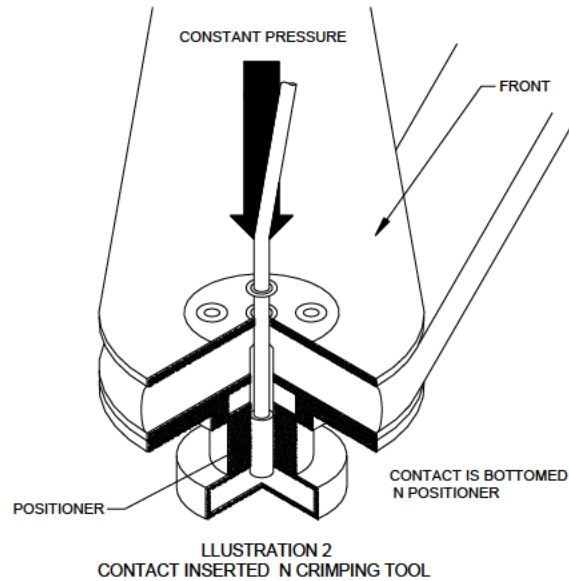

ILLUSTRATION 1
TYPICAL CRIMP CONTACT

7. Turn the crimping tool so the front is facing the operator.
8. Insert the wire and contact through the indentors until it bottoms in the positioner (see illustration 2).

FIGURE 5A4. Connector contact crimping techniques.

MIL-STD-2003-5B(SH)
APPENDIX 5A



Connector contact crimping techniques (continued):

9. Hold the wire in place and squeeze the handles until the ratchet releases and the tool opens. The crimping cycle is controlled by means of a ratchet that will not release until the crimping cycle has been completed.
10. Remove the crimped contact after releasing the handles.
11. Inspect the crimped contact for the following:
 - a. Even crimp.
 - b. Wire visible in inspection hole.
 - c. $\frac{1}{32}$ -inch maximum gap between contact and insulation for 20 gauge and smaller, $\frac{1}{16}$ -inch maximum gap between contact and insulation for 18 gauge and larger (see illustration 1).
12. Lightly pull on inserted lead to ensure contact has locked in connector.
13. Rework any failed crimped contact.
 - a. Failed crimped contacts should be removed by cutting the contact just above the crimped area.

FIGURE 5A4. Connector contact crimping techniques – Continued.

MIL-STD-2003-5B(SH)
APPENDIX 5A



ILLUSTRATION 4
M L-DTL-22520 CRIMPING TOOLS

FIGURE 5A4. Connector contact crimping techniques – Continued.

MIL-STD-2003-5B(SH)
APPENDIX 5A

TABLE 5A4-I. Wire barrel size.

Wire barrel size	Wire size range	Axial load (pounds)		
		Silver- or tin-plated copper wire	Nickel-plated copper wire	Copper alloy wire
0000	0000	25	25	
	00 ^{1/}	25	25	
0	0	25	25	
	2 ^{1/}	25	25	
2	2	25	25	
	4 ^{1/}	25	25	
4	4	25	25	
	6 ^{1/}	25	25	
6	6	25	25	
	8 ^{1/}	25	25	
8	8	25	25	
	10 ^{1/}	25	25	
10	10	25	25	
	12 ^{1/}	25	25	
12	12	25	25	
	14	25	25	
16	16	25	18.5	
	20	10	9.5	
20	20	10	6.5	25
	24	4	3	9
22	22	6	4	15
	26	2.5	1.5	6
24	24	4	2.5	9
	28	1.5	1.0	3.5
26	26	2.2	1.4	5.5
	30	0.7	0.7	2
28	28	1.3	0.9	3.2
	32	0.5	0.5	1.2

NOTE:
^{1/} With electrically conductive bushing.

FIGURE 5A4. Connector contact crimping techniques – Continued.

MIL-STD-2003-5B(SH)
APPENDIX 5A

Tinning techniques:

1. Observe the following prior to commencing work:
 - a. Solder Sn 60 or Sn 63 tin lead form W or B, type R, RMA, or S conforming to J-STD-006 shall be used for pre-tinning.
 - b. Only rosin flux shall be used in all soldering operations. Liquid rosin flux shall conform to J-STD-004, J-STD-005, and J-STD-006, as appropriate, type RMA, except that the copper mirror test is not required and the resistivity of the water extract shall be at least 45,000 ohm-centimeters.
 - c. Soldering guns shall not be used and the use of a solder pot is not recommended. When conductors are tinned with a soldering iron, only ironclad tips shall be used. The following rules apply to soldering iron maintenance:
 - (1) The soldering iron tip shall always be checked for full insertion into the heating element and tight attachment to the iron. Oxidation scale shall not be allowed to accumulate between the heating element and the tip. The barrel of the cold iron shall be cleaned with a soft pipe cleaner or object when tip is removed, or once a week. A continuous tinned surface shall be maintained on the tip working-surface to ensure proper heat transfer and to avoid transfer of impurities to the solder connection.
 - (2) Plated tips shall be cleaned by scrubbing action on an alumina substrate (ceramic) while the iron is hot. Tin the tip by immersion in a ball of solder and flux until a bright shiny solder-coated surface is visible. Fine emery cloth may be substituted for ceramic substrate.
 - (3) Never file an ironclad soldering tip.
 - (4) During use and just before each application, the heated and tinned soldering tip should be maintained by passing the tip (with a rotary motion) through the folds of a damp cleaning sponge. This removes the surface dross from the working surface. Never shake or “whip” the iron to remove excess solder. Use Kimwipes® (or equal, see 4.2) or cloth diapers to remove excess solder.
2. Tinning with soldering iron (see illustration 1):
 - a. Check the wire for adequate strip length (as required by [figure 5A3](#)) and for nicks, cut strands, or other damage. If rejectable defects are evident, re-strip in accordance with [figure 5A3](#) as long as the wire length is adequate. If the wire length is not adequate, replace the wire.
 - b. The size of the soldering iron to be used should be determined from [table 5A5-I](#) based on the size of the wire being tinned.

TABLE 5A5-I. Soldering iron size.

Wire size (AWG)	Soldering element size – maximum wattage capacity	Maximum tip temperature
0	150 W	1000 °F
4	150 W	1000 °F
8	150 W	1000 °F
10	75 W	800 °F
12	60 W	800 °F
16	50 W	800 °F
20	35 W	800 °F
22	35 W	800 °F
24-26	24 W	800 °F

- c. Select a soldering iron tip that will give the maximum “contact” to the connection. Illustration 1 shows representative tips and is not intended as a selection guide.

FIGURE 5A5. Tinning techniques.

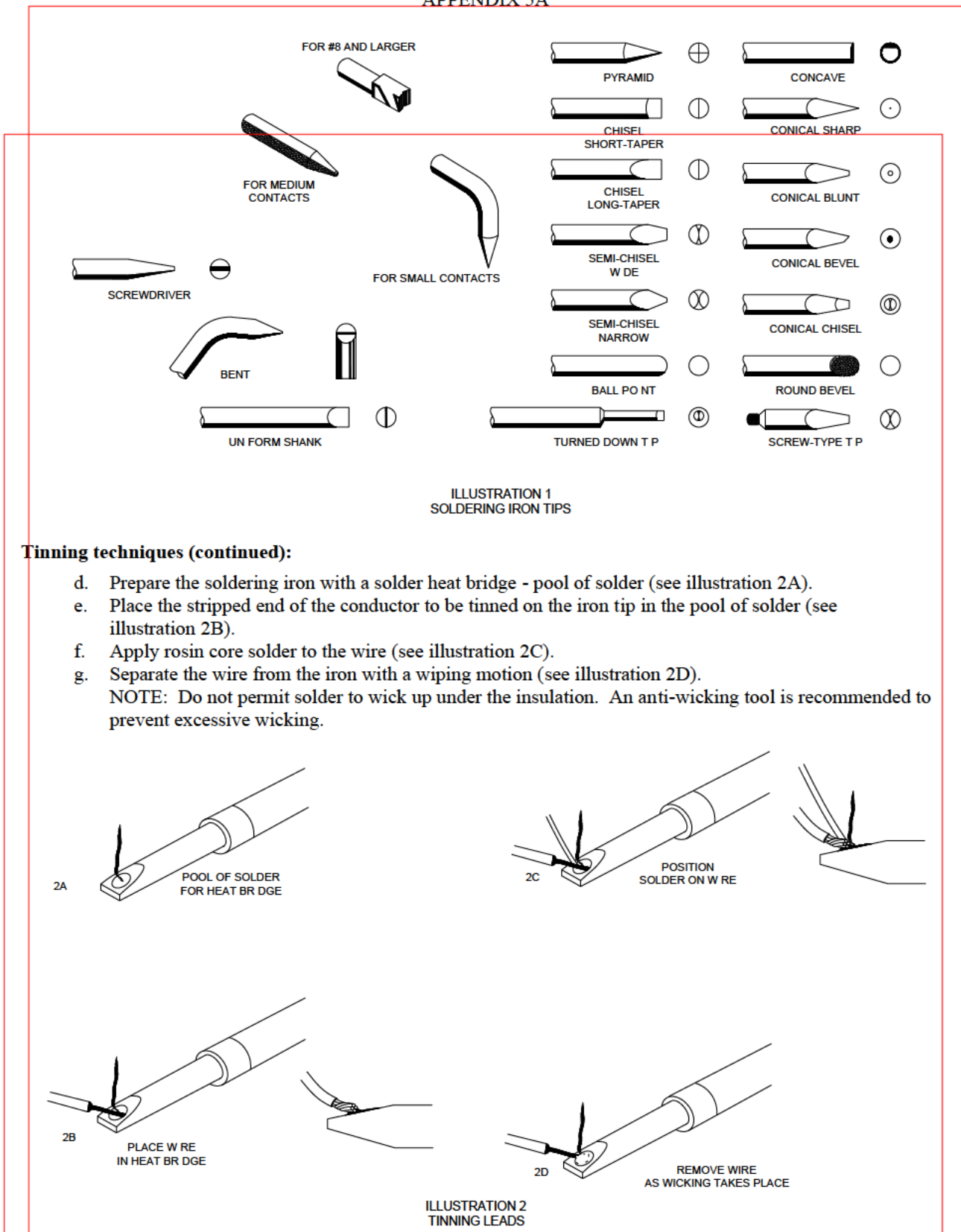
MIL-STD-2003-5B(SH)
APPENDIX 5A**Tinning techniques (continued):**

- d. Prepare the soldering iron with a solder heat bridge - pool of solder (see illustration 2A).
 - e. Place the stripped end of the conductor to be tinned on the iron tip in the pool of solder (see illustration 2B).
 - f. Apply rosin core solder to the wire (see illustration 2C).
 - g. Separate the wire from the iron with a wiping motion (see illustration 2D).
- NOTE: Do not permit solder to wick up under the insulation. An anti-wicking tool is recommended to prevent excessive wicking.

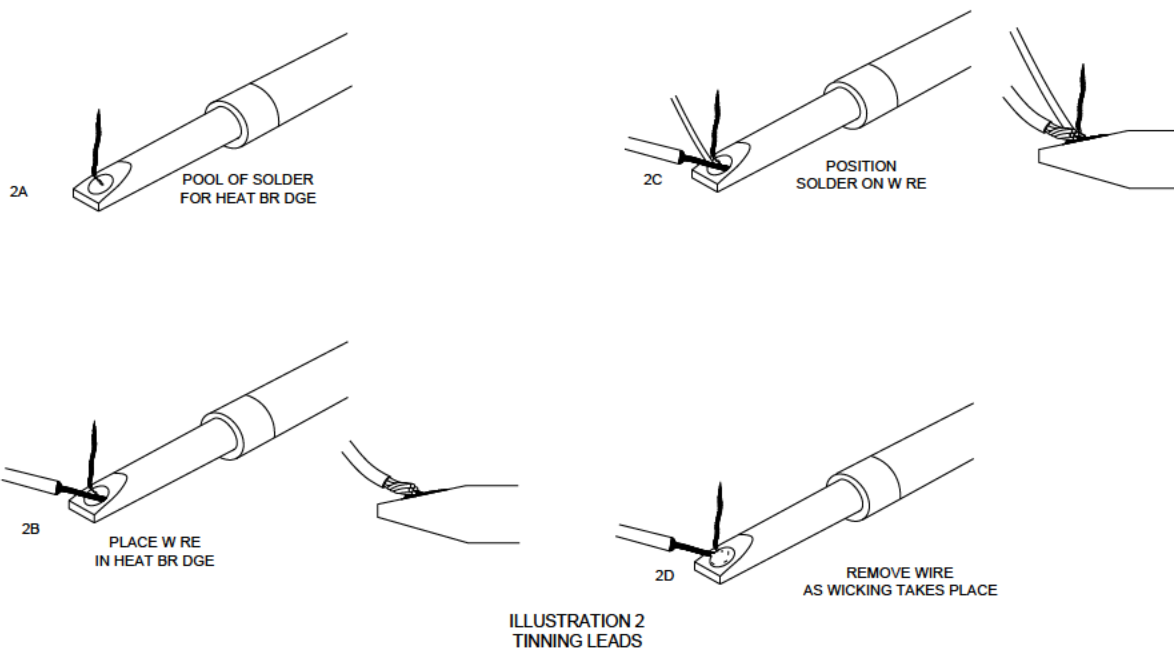
FIGURE 5A5. Tinning techniques – Continued.

MIL-STD-2003-5B(SH)
APPENDIX 5A

ILLUSTRATION 3B
COLD SOLDER



SHIELD PIGTAILS



ACCEPTABLE

STRANDS VISIBLE UNDER SOLDER
SLIGHT BULGING IN APPEARANCE
SOLDER FEATHERS TO BASE METAL



REJECT

BALLED SOLDER DOES NOT WET ALL SURFACES
SOLDER WETTING IS NOT EVIDENT ON ALL SURFACES
SOLDER SURFACE IS NOT SMOOTH AND CONTINUOUS

ILLUSTRATION 3A
EXCESSIVE/BALLED SOLDER



SHIELD PIGTAILS



ACCEPTABLE

STRANDS PARTIALLY OBSCURED
FILLET SURFACE IS STRAIGHT, NOT CONCAVE



REJECT

SOLDER SPLATTERS
FILLET SURFACE IS BALLED UP,
NOT STRAIGHT OR CONCAVE
STRANDS NOT VISIBLE

FIGURE 5A5. Tinning techniques – Continued.

MIL-STD-2003-5B(SH)
APPENDIX 5A

ILLUSTRATION 4B
EXCESSIVE WICKING/DAMAGED INSULATION

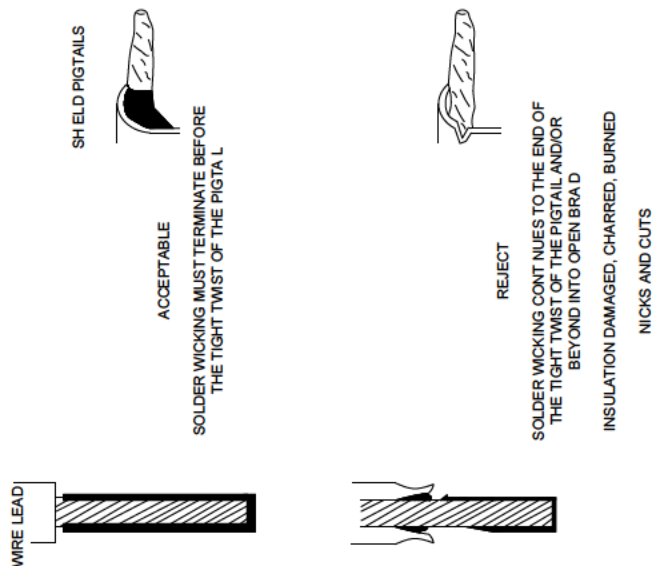

ILLUSTRATION 4A
BUCKLED WIRESTRANDS

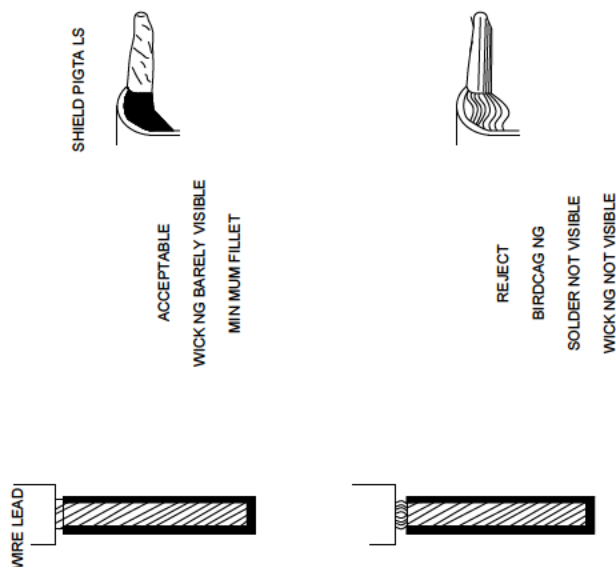

FIGURE 5A5. Tinning techniques – Continued.

MIL-STD-2003-5B(SH)
APPENDIX 5A

Connector contact soldering techniques:

1. Solder Sn 60 or Sn 63 tin lead form W, type R, or RMA conforming to J-STD-006 shall be used for connector soldering.
2. Only rosin flux shall be used in all soldering operations. Liquid rosin flux shall conform to J-STD-004, J-STD-005, and J-STD-006, as appropriate, type RMA, except that the copper mirror test is not required, and the resistivity of the water extract shall be at least 45,000 ohm-centimeters.
3. Soldering iron tips to be used for connector assembly shall be ironclad. The soldering iron and style should provide a large contact area with the solder cup for maximum heat transfer. The following notes apply to soldering iron tip maintenance:
 - a. The soldering iron tip shall always be checked for full insertion into the heating element and tight attachment to the iron. Oxidation scale shall not be allowed to accumulate between the heating element and the tip. The barrel of the cold iron shall be cleaned with a soft pipe cleaner or similar object when the tip is removed, or once a week. A bright thin, but continuous, tinned surface shall be maintained on the tip working-surface to ensure proper heat transfer and to avoid transfer of impurities to the solder connection (see illustration 1).

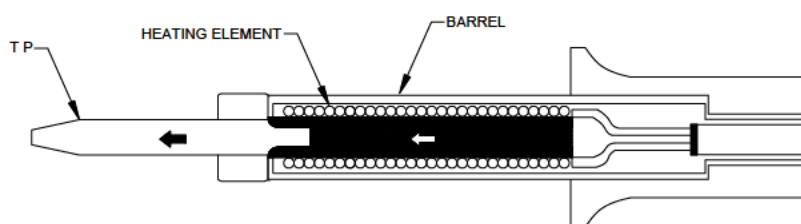

ILLUSTRATION 1 - SOLDERING IRON COMPONENTS

- b. Plated tips shall be cleaned by scrubbing action on an alumina substrate (ceramic) while the iron is hot. Tin the tip by immersion in a ball of solder and flux until a bright shiny solder-coated surface is visible. Fine emery cloth may be substituted for ceramic substrate.
 - c. Never file an ironclad soldering tip.
 - d. During use and just prior to each application, the heated and tinned soldering tip should be maintained by passing the tip (with a rotary motion) through the folds of a damp cleaning sponge. This removes the surface dross from the working surface. Never shake or "whip" the iron to remove excess solder. Use Kimwipes® (or equal, see 4.2) or cloth diapers to remove excess solder.
4. Cleaning and cleaning solvents: Grease, oil, and other dirt shall be removed from the parts prior to soldering. Flux residues shall be removed from the joint area. Solvents listed in [table 5A6-I](#) may be used for the cleaning.

TABLE 5A6-I. Cleaning solvents.

Solvent	Specification
Isopropyl alcohol	TT-I-735
Perchloroethylene	ASTM D4376
Reagent water (type II)	ASTM D1193
Detergent cleaner	As approved by the Government procuring activity

FIGURE 5A6. Conductor contact soldering techniques.

MIL-STD-2003-5B(SH)
APPENDIX 5A

Connector contact soldering techniques (continued):

5. Method:

- a. If required, place lengths of insulating sleeve on each pre-tinned lead to be soldered, and position out of the way for soldering.
 - (1) Insulation sleeving shall meet the requirements of SAE-AS23053/5, type 1, as appropriate.
 - (2) Insulating sleeves are not required in miniature MS connectors or in MS type, class E or R connectors because the sealing grommets cover the soldered connection. Class E connectors made by Bendix require insulating sleeves because the grommets do not cover the soldered connection. The insulating sleeve shall not extend into the grommet.
 - (3) Polyvinyl chloride plastics shall not be used.
 - (4) The sleeve length shall cover the entire solder terminal and overlap conductor insulation by two wire diameters (plus insulation) (see illustration 2).
 - (a) Tubing shall be tight on terminal initially and when repositioned after connector inspection.
 - (5) Heat shrink tubing is not recommended. If used, it should not be shrunk.

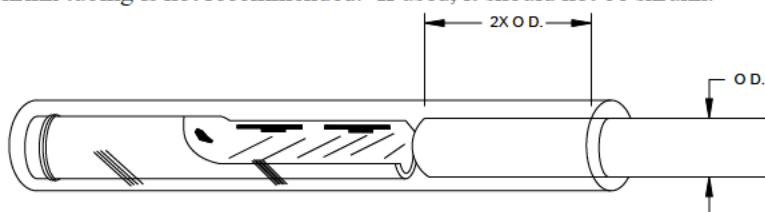

ILLUSTRATION 2 - TUBING LENGTH

- b. Pre-tin solder terminal cups as follows (see illustration 3):
 - (1) Support solder terminal cup at an angle as shown (see illustration 3A).
 - (2) Apply soldering iron tip or resistance soldering tongs to the side of the solder cup to heat the solder cup. Soldering iron size should be selected from [table 5A6-II](#) based on wire size.

TABLE 5A6-II. Soldering iron size.

Wire size	Soldering element size – maximum wattage capacity	Maximum tip temperature
0	150 W	1000 °F
4	150 W	1000 °F
8	150 W	1000 °F
10	75 W	800 °F
12	60 W	800 °F
16	50 W	800 °F
20	35 W	800 °F
22	35 W	800 °F
24-26	24 W	800 °F

- (3) Apply solder to the inside of the cup cavity as the solder melts and begins to flow into the cup. Slowly add solder until the cup is filled to the proper level (the pre-fill level should be determined such that the cup will be properly filled when the tinned wire is placed in the pre-filled terminal cup) (see illustration 3B).

CAUTION: Step c below should be accomplished quickly to prevent excess wicking under the wire insulation.

- c. While the solder cup is still heated, insert the tinned wire into the cup cavity slowly and at an angle. Then tip the wire into place to allow the solder to flow. Ensure that the wire is bottomed in the solder cup before removing the soldering iron (see illustration 4).

NOTE: The use of an anti-wicking tool is recommended.

FIGURE 5A6. Conductor contact soldering techniques – Continued.

MIL-STD-2003-5B(SH)
APPENDIX 5A

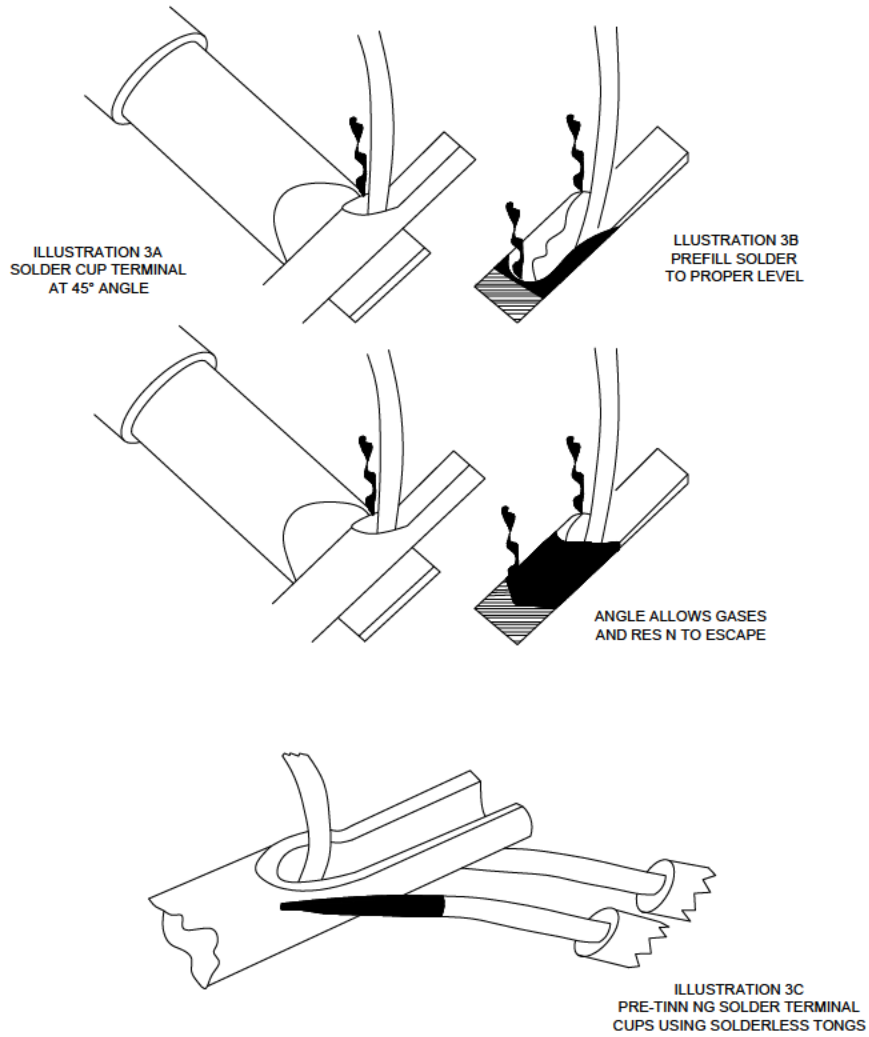
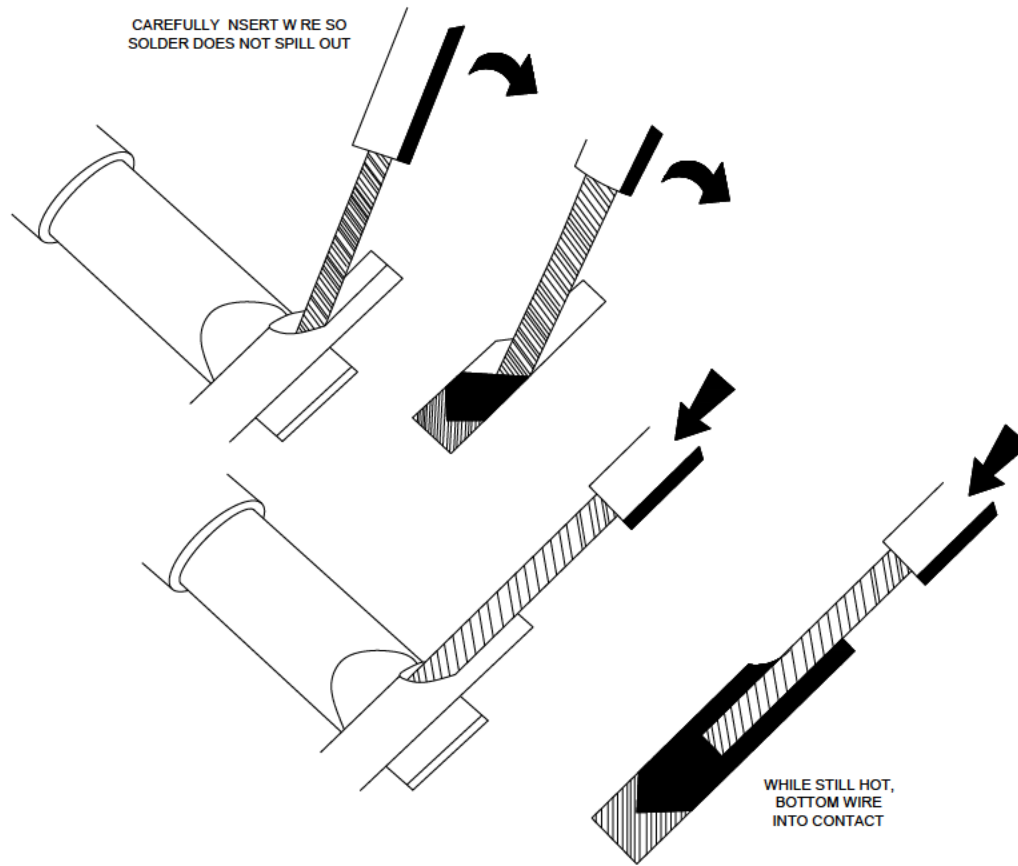

ILLUSTRATION 3 - PRE-TINNING THE SOLDER TERMINAL CUPS

FIGURE 5A6. Conductor contact soldering techniques – Continued.

MIL-STD-2003-5B(SH)
APPENDIX 5AILLUSTRATION 4
WIRE INSERTION IN CONTACT**Connector contact soldering techniques (continued):**

- d. Remove the soldering iron or resistance soldering tongs from the solder terminal cup.
- e. Support the wire without movement while the solder cools and solidifies.
- f. Clean the soldered connection with a non-metal fiber brush dampened in solvent (step 4). Remove all traces of flux and solvent residues by blotting the area dry with an absorbent lint-free material.
- g. Alternate method: Pre-fill all solder cups (step 5.b), then proceed with installing wires (steps 5.c through 5.f).
- h. Visually inspect solder connection for compliance with the following criteria:
 - (1) Clean, smooth, bright, undisturbed surface with a concave fillet between all strands and from conductor to cup.
 - (2) Solder shall not wick under conductor insulation.
 - (3) Insulation shall not be damaged or deformed.
 - (4) Wire insulation shall not be imbedded in the solder joint. Maximum insulation clearance shall be two wire diameters including insulation, or $\frac{1}{16}$ inch, whichever is larger.
 - (5) Examples of rejectable defects are shown in illustrations 5A-5J.

FIGURE 5A6. Conductor contact soldering techniques – Continued.

MIL-STD-2003-5B(SH)
APPENDIX 5A

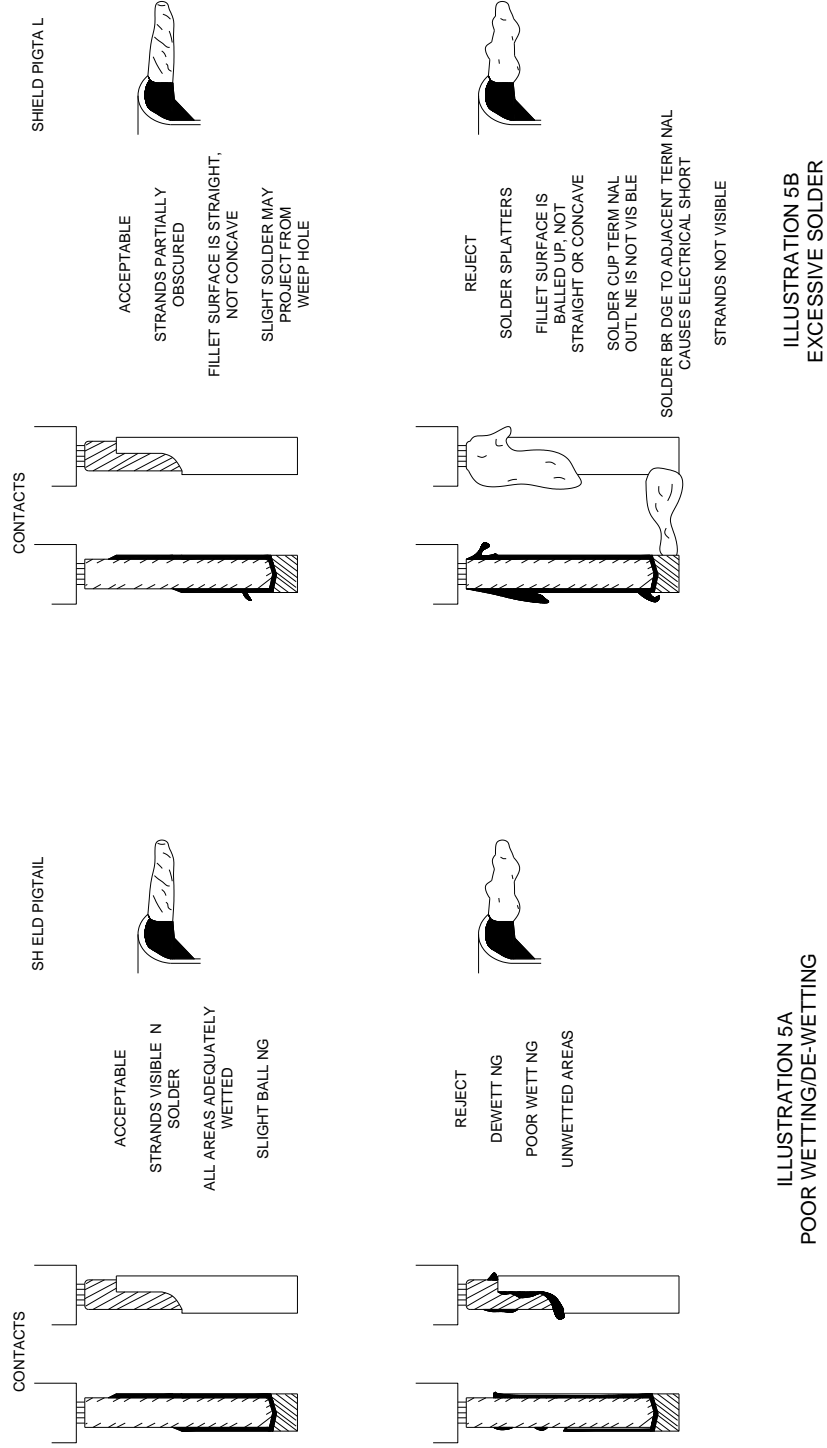

FIGURE 5A6. Conductor contact soldering techniques – Continued.

MIL-STD-2003-5B(SH)
APPENDIX 5A

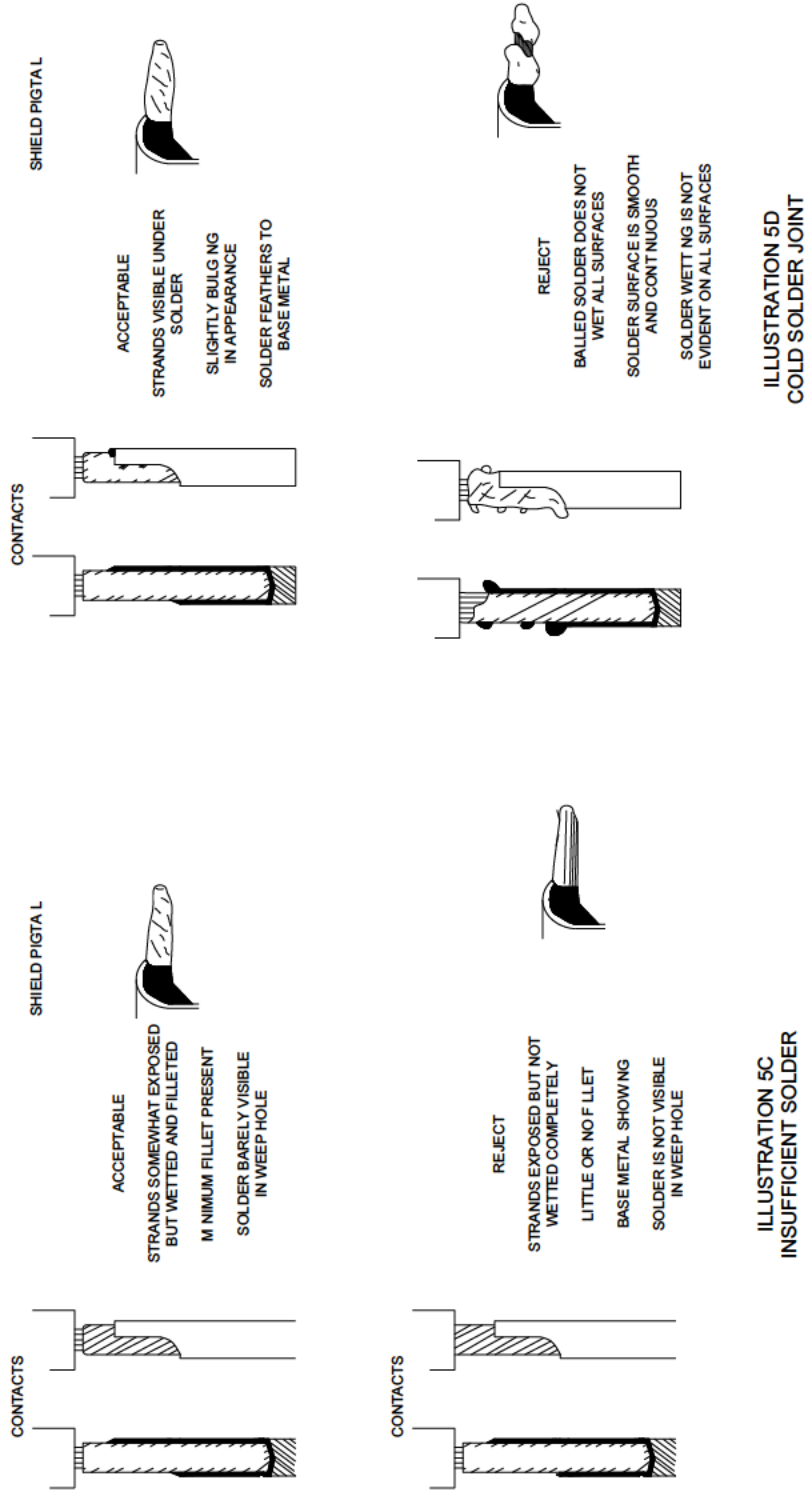

FIGURE 5A6. Conductor contact soldering techniques – Continued.

MIL-STD-2003-5B(SH)
APPENDIX 5A

ILLUSTRATION 5F
OVERHEATED JOINT

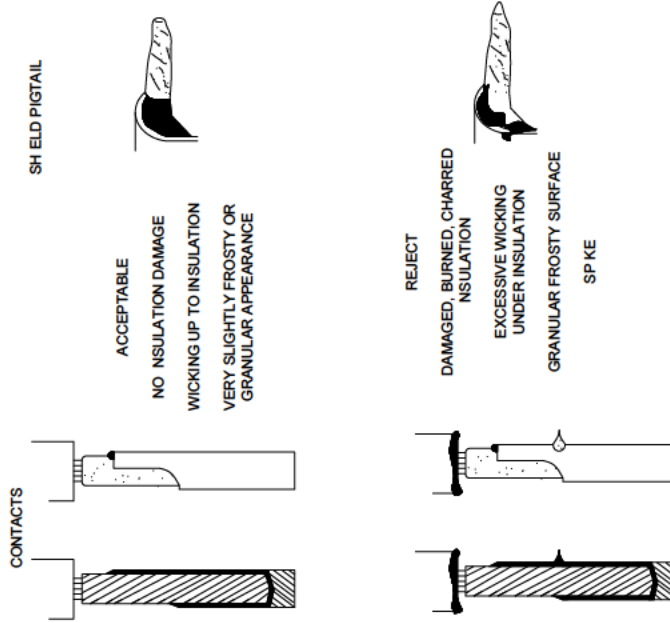

ILLUSTRATION 5E
FRACTURED/DISTURBED JOINT

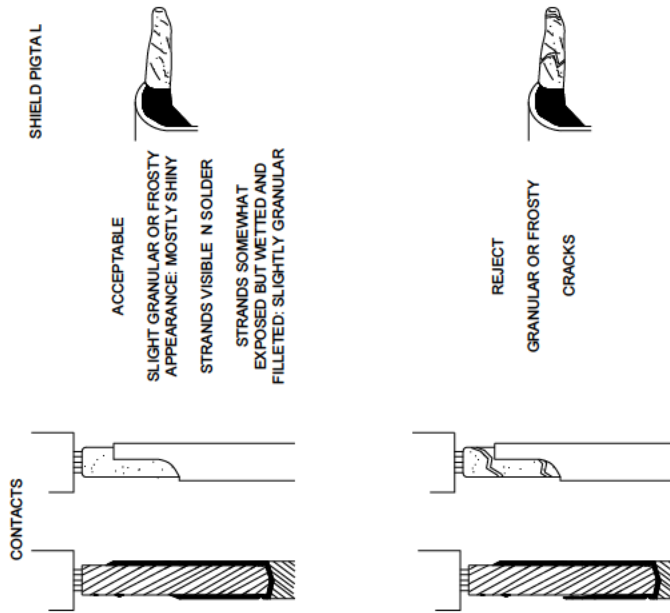

FIGURE 5A6. Conductor contact soldering techniques – Continued.

MIL-STD-2003-5B(SH)
APPENDIX 5A

ILLUSTRATION 5H
INSUFFICIENT WICKING

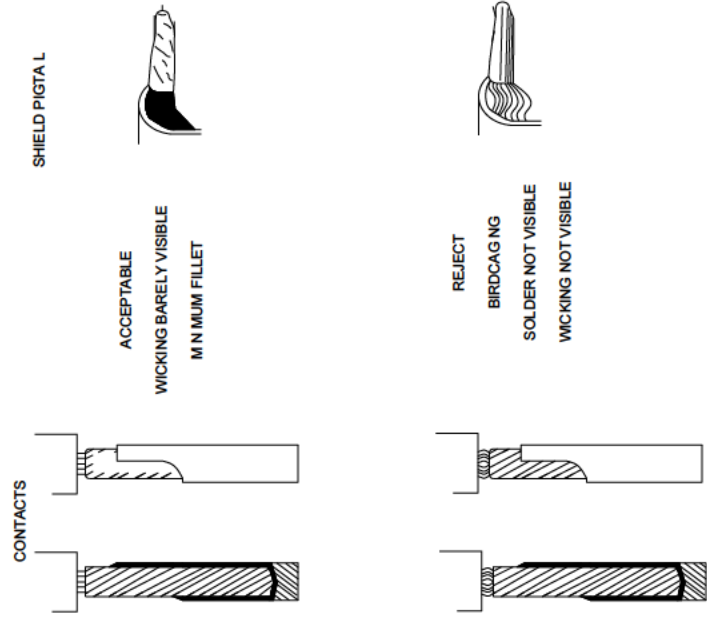

ILLUSTRATION 5G
EXCESSIVE WICKING

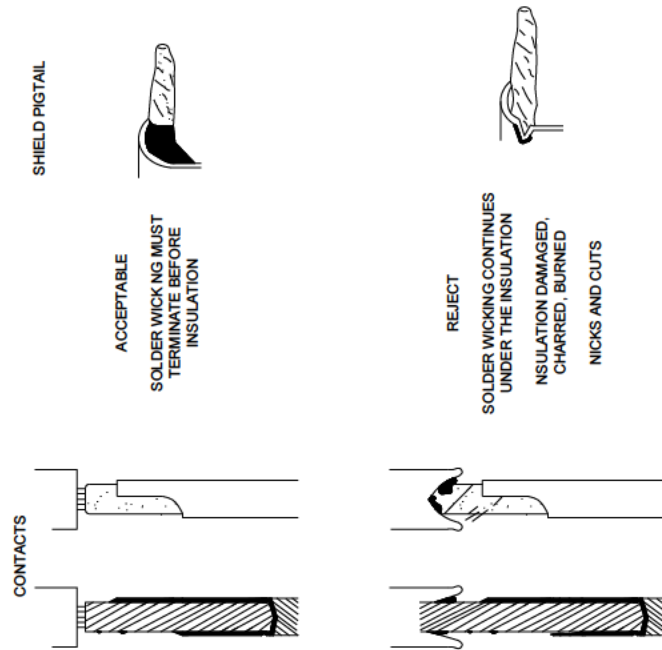

FIGURE 5A6. Conductor contact soldering techniques – Continued.

MIL-STD-2003-5B(SH)
APPENDIX 5A

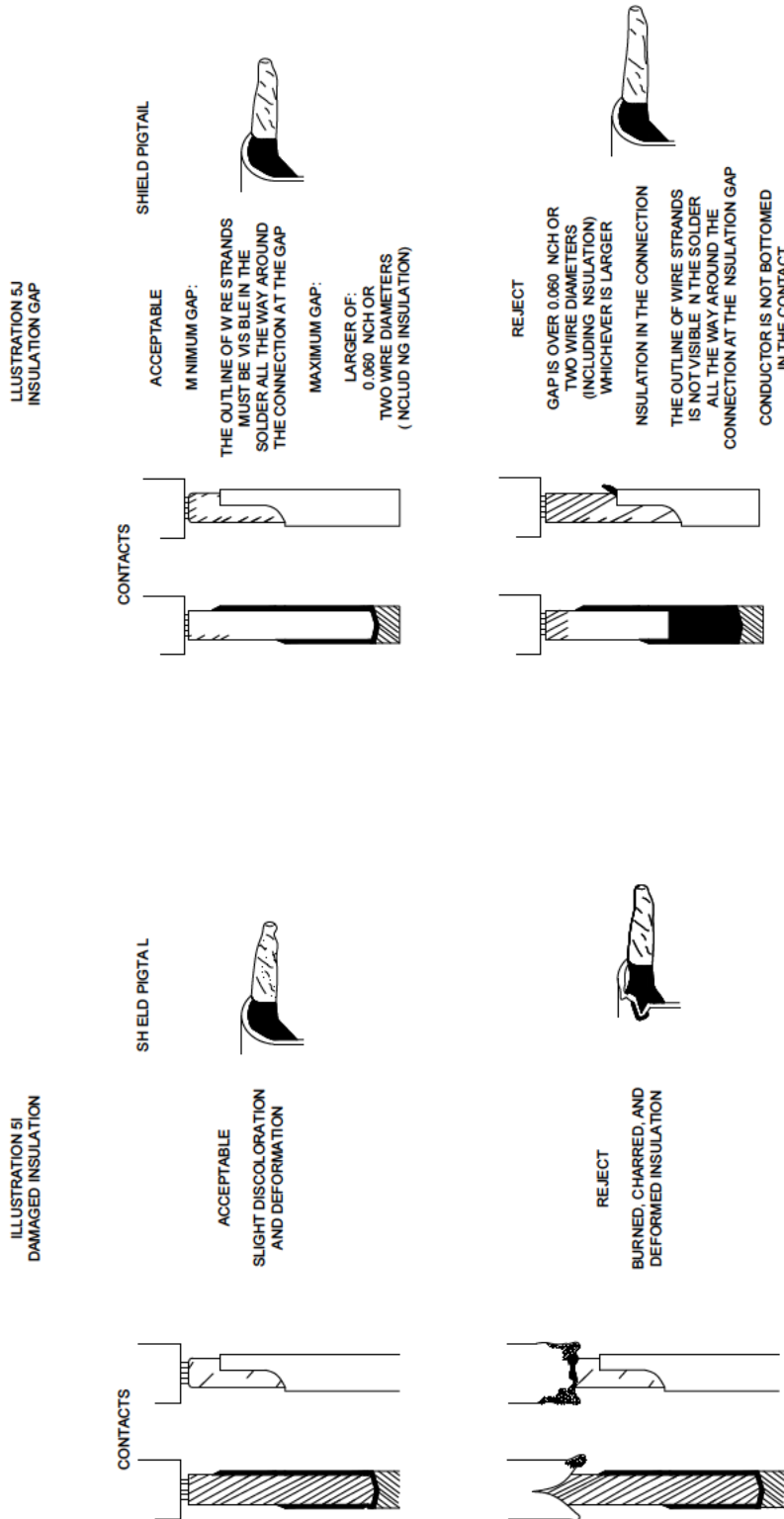

FIGURE 5A6. Conductor contact soldering techniques – Continued.

MIL-STD-2003-5B(SH)
APPENDIX 5A

Connector contact soldering techniques (continued):

6. The following de-soldering methods shall be used when the soldered connection requires repair, rework, or replacement.

a. Vacuum method:

- (1) Install an anti-wicking tool in order to prevent migration of excess heat and solder (see illustration 6A).
- (2) Apply a very light coat of flux to the solder connection (see illustration 6B).

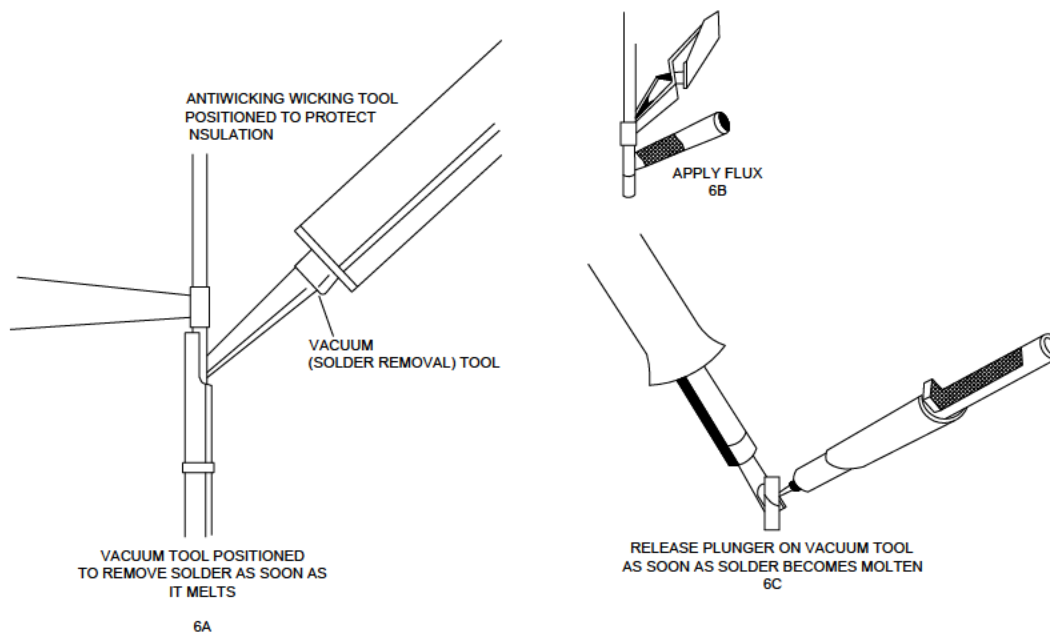

ILLUSTRATION 6 - DE-SOLDERING (VACUUM METHOD)

- (3) Heat solder cup until molten and remove wire.
 - (4) Select a vacuum tool tip to properly fit the solder connection.
 - (5) Load or cock the vacuum tool.
 - (6) Place the vacuum tool tip adjacent to the soldered connection (see illustration 6A).
 - (7) Heat the solder joint (until molten) with a soldering iron then release the vacuum tool trigger device (see illustration 6C).
 - (8) Remove the soldering iron and vacuum tool.
 - (9) Examine the connection for adequate solder removal.
 - (10) Repeat steps 6.a(6) through 6.a(9) until only a thin film of solder remains.
 - (11) Clean the connection with an approved solvent from [table 5A6-I](#).
- b. Wicking braid method:
- (1) Install an anti-wicking tool in order to prevent migration of excess heat or solder.
 - (2) Apply a light coat of liquid flux to solder connection.
 - (3) Heat solder cup until molten and remove wire.
 - (4) Apply a light coat of flux to the wicking wire.
 - (5) Place wicking braid over solder to be removed.
 - (6) Place heat on wicking braid. Remove heat and wicking braid simultaneously when the solder has saturated the wicking braid (see illustration 7).

FIGURE 5A6. Conductor contact soldering techniques – Continued.

MIL-STD-2003-5B(SH)
APPENDIX 5A

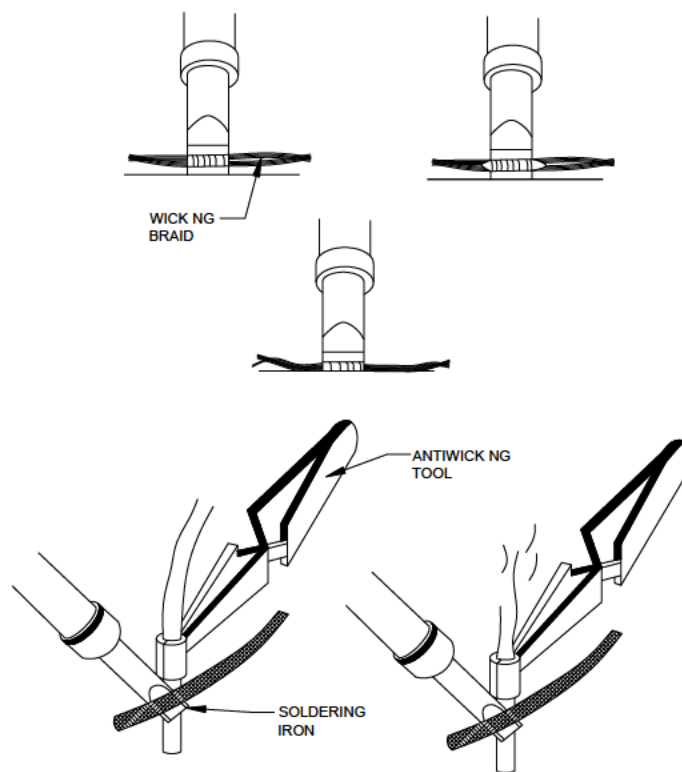

ILLUSTRATION 7 - BRAIDED WICK WIRE SOLDER REMOVAL

Connector contact soldering techniques (continued):

- (7) Repeat steps 6.b(1) through 6.b(4) until de-soldering is complete, leaving only a thin film of solder on the connection.
- (8) Clean connection with approved solvent from [table 5A6-I](#).

FIGURE 5A6. Conductor contact soldering techniques – Continued.

MIL-STD-2003-5B(SH)
APPENDIX 5A

Conductor shield termination procedures:

1. Verify that the shield braiding is not cut, nicked, or damaged.
2. Inspect all termination hardware (i.e., rings, ferrules, solder sleeves, etc.) to ensure they are the correct type and size for the connector being assembled and are free of tarnish, corrosion, or damage.
3. Shield termination shall be in accordance with applicable system wiring tables and design data. In addition, the following applies:
 - a. Shield terminations shall be staggered in order to limit buildup of the assembly diameter.
 - b. Shield terminations shall not be positioned as to occur under cable clamps or within the potted areas of connectors.
 - c. The use of an appropriate heat barrier when shrinking solder sleeves is preferred to minimize damage to conductor insulation. A heat barrier can be a heat-resistant, flexible material such as several layers of glass tape applied back-to-back (adhesive-to-adhesive) of sufficient width to provide the protection needed for conductor insulation.

4. Shield termination to a conductor using the solder ferrule method:

NOTE: If a solder ferrule of the correct size cannot be utilized, terminate the shield using step 5.

- a. Strip outer jacket from conductors, staggering the distances between each (see illustration 1).

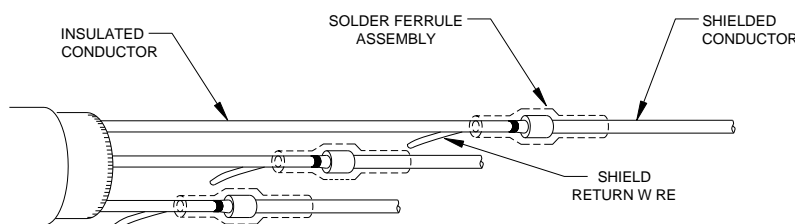

ILLUSTRATION 1 - STAGGERED SHIELD TERMINATIONS

NOTE: Ensure conductors are identified before removing insulation.

- b. Trim the shields to $\frac{3}{8}$ -inch length (see illustration 3).
- c. Strip $\frac{3}{8}$ inch of insulation from the shield return wire in accordance with [figure 5A3](#) (see illustration 3).
 - (1) Unless the shield return wire is supplied with the solder ferrule, the shield return wire shall be fabricated from insulated flexible stranded wire with the same physical characteristics as the conductor.
 - (2) Unless the shield return wire is supplied with the solder ferrule, when terminated to a connector contact, the wire size shall be governed by the contact to which it is being attached.
 - (3) The length shall allow the shield return wire to extend beyond the shielded conductor after attachment to the shield.
- d. Tin the stripped shield return wire using a solder with a melting temperature approximately the same as the preformed solder in the ferrule (see [figure 5A5](#)).
- e. When a heat barrier is used (preferred method), spread the braided shield slightly open, and slide the heat barrier under the braid until it bottoms. The length of the heat barrier shall be selected as required for the protection of wire insulation near the solder operation.
- f. Position the stripped end of the conductor against and parallel to the exposed shielding.

NOTE: The shield return wire may extend from the front (when terminating to a contact) or rear (when terminating to another shield) of the solder ferrule as required.

 - (1) Ensure the shield return wire strands and shield braid strands are flat and smooth.
- g. Select a solder ferrule meeting the requirements of SAE-AS83519, as appropriate, that will fit freely but will not be excessively loose on the shield and shield return lead connection. [Table 5A7-I](#) is provided as an example of solder ferrule sizes available.
 - (1) Solder ferrules consist of a heat shrinkable sleeve containing a preform of fluxed solder at the center and a thermoplastic sealing ring in each end (see illustration 2).

FIGURE 5A7. Conductor shield termination procedures.

MIL-STD-2003-5B(SH)
APPENDIX 5A

TABLE 5A7-I. Solder ferrule sizes.

Part number	Dimensions (inch)			
	As supplied			Aft shrinking outside diameter (max.)
	A (min.)	B (min.)	C (min.)	
M83519/1-2	0.65±0.06	0.105	0.145	0.120
M83519/1-3	0.65±0.06	0.170	0.200	0.150
M83519/1-5	0.75±0.06	0.275	0.300	0.210

Conductor shield termination procedures (continued):

- h. Position the solder ferrule over the assembly so that the solder ring is centered over the shielding and shield return wire conductor (see illustration 3).

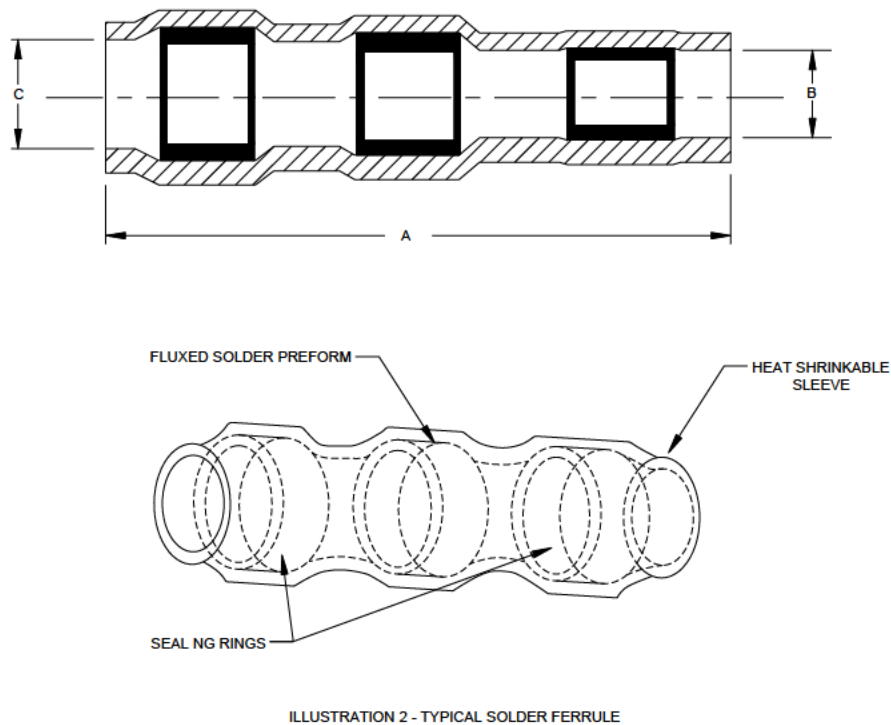
FIGURE 5A7. Conductor shield termination procedures – Continued.

MIL-STD-2003-5B(SH)
APPENDIX 5A

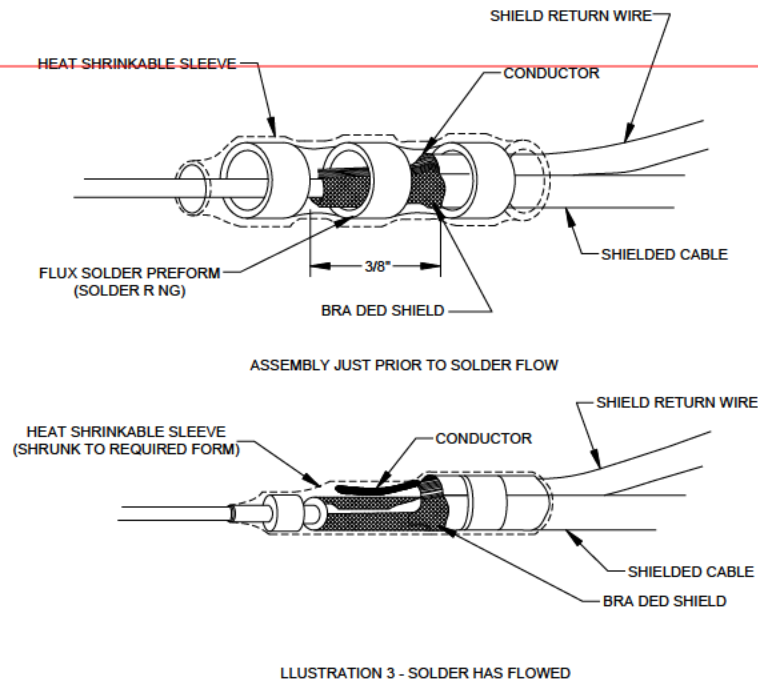

Conductor shield termination procedures (continued):

CAUTION: Use extreme care while applying heat in order to avoid damaging the conductor insulation due to melting.

- i. Using a heat gun and thermal reflector, as appropriate, heat the assembly while rotating to achieve proper solder penetration and uniform sleeve shrinkage (see illustration 4).
 - (1) Apply heat until the solder brightens and starts to flow toward the thermoplastic inserts or when the solder ferrule thermal indicator, if installed, indicates that sufficient heat has been applied.

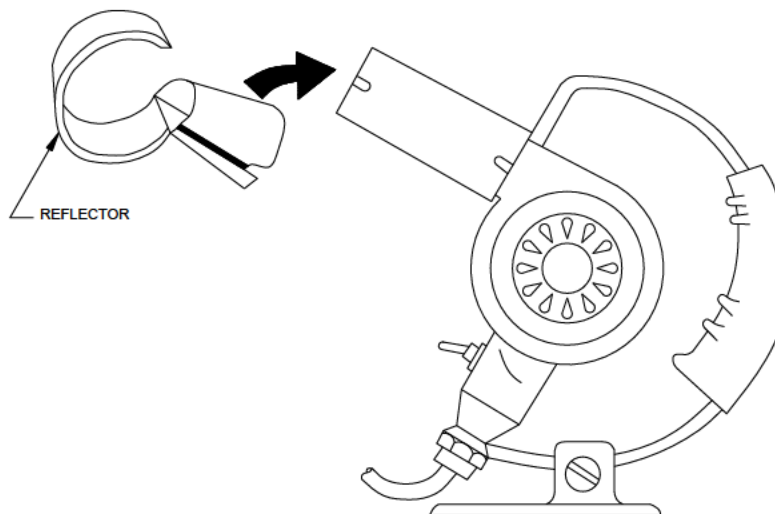

ILLUSTRATION 4 - TYPICAL HEAT GUN

FIGURE 5A7. Conductor shield termination procedures – Continued.

MIL-STD-2003-5B(SH)
APPENDIX 5A

Conductor shield termination procedures (continued):

- j. Hold the assembly firmly until the solder joint is set.
- k. Inspect the solder ferrule.
 - (1) The exposed shield wire shall be visible on both sides of the solder ring but not extend beyond the heat shrinkable inserts.
 - (2) The ferrule solder should appear continuous and smooth with concave fillet between shield and return wire lead.
 - (3) The insulation of the shield return shall be enclosed under the heat shrinkable insert.
 - (4) The thermoplastic insert should collapse over the shield return wire and conductor shielding.
 - (5) The ferrule shield shall not be cut, split, or have strands protruding.
- l. Terminate shield return wire with other conductors in accordance with the applicable system connector assembly procedure.
- 5. Shield termination to a connector using the two-piece crimp ferrule method:
 - a. Strip outer jacket from conductors, staggering the distances between each (see illustration 1).
 - b. Trim the shields ½-inch to ¾-inch length (see illustration 5A).

FIGURE 5A7. Conductor shield termination procedures – Continued.

MIL-STD-2003-5B(SH)
APPENDIX 5A

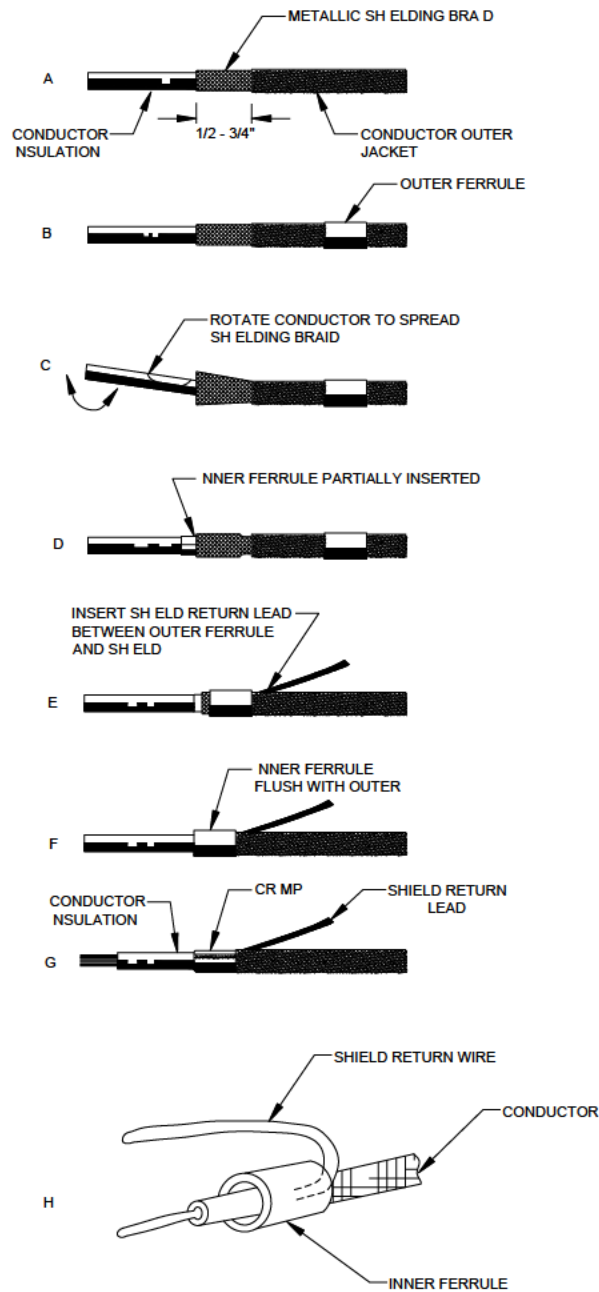

ILLUSTRATION 5 - TWO PIECE GROUNDING CONNECTION FOR TERMINATING SHIELDED WIRE

Conductor shield termination procedures (continued):

- c. Determine the maximum conductor diameter (see individual lead stripping techniques, [table 5A3-II](#)) and add 0.005 inch.
- d. Select the inner ferrule from [table 5A7-II](#) having the inner diameter nearest, but larger than the dimension calculated in step 5.c. Ensure the inner ferrule meets the requirements of SAE-AS21608 and SAE-AS21981.

FIGURE 5A7. Conductor shield termination procedures – Continued.

MIL-STD-2003-5B(SH)
APPENDIX 5A

TABLE 5A7-II. Shielded wire terminations: inner ferrule sizes.

Part number	Color code	Inner ferrule (nominal)	
		I.D.	O.D.
MS21981-046	Tin	0.046	0.070
MS21981-058	Yellow	0.058	0.083
MS21981-063	Red	0.063	0.088
MS21981-071	Green	0.071	0.096
MS21981-080	Blue	0.080	0.104
MS21981-090	Orange	0.090	0.114
MS21981-096	Purple	0.096	0.119
MS21981-101	Yellow	0.101	0.124
MS21981-109	Red	0.109	0.131
MS21981-115	Tin	0.115	0.146
MS21981-124	Green	0.124	0.145
MS21981-128	Tin	0.128	0.152
MS21981-134	Orange	0.134	0.156
MS21981-149	Blue	0.149	0.179
MS21981-156	Red	0.156	0.192
MS21981-165	Tin	0.165	0.194
MS21981-175	Green	0.175	0.215
MS21981-187	Yellow	0.187	0.227
MS21981-194	Blue	0.194	0.225
MS21981-205	Orange	0.205	0.245
MS21981-219	Tin	0.219	0.248
MS21981-225	Yellow	0.225	0.256
MS21981-232	Red	0.232	0.263
MS21981-250	Green	0.250	0.281
MS21981-261	Blue	0.261	0.297
MS21981-266	Tin	0.266	0.297
MS21981-275	Orange	0.275	0.306
MS21981-281	Yellow	0.281	0.331
MS21981-287	Tin	0.287	0.327
MS21981-297	Red	0.297	0.335
MS21981-312	Purple	0.312	0.362
MS21981-375	Blue	0.375	0.406

Conductor shield termination procedures (continued):

- e. Add $\frac{1}{16}$ inch to the outer diameter of the inner ferrule selected in step 5.d. Select an insulated outer ferrule from [table 5A7-III](#) that meets the requirements of SAE-AS21608 and SAE-AS18121 with the above dimension as the minimum inner diameter.

FIGURE 5A7. Conductor shield termination procedures – Continued.

MIL-STD-2003-5B(SH)
APPENDIX 5ATABLE 5A7-III. Shielded wire terminations:
insulated outer ferrule sizes.

Part number	Color code	Inner ferrule (nominal) ± 0.005
MS18121-101	Tin	0.101
MS18121-128	Blue	0.128
MS18121-149	Purple	0.149
MS18121-156	Yellow	0.156
MS18121-175	Blue	0.175
MS18121-187	Orange	0.187
MS18121-194	Red	0.194
MS18121-199	Tin	0.199
MS18121-205	Yellow	0.205
MS18121-219	Green	0.219
MS18121-225	Purple	0.225
MS18121-232	Orange	0.232
MS18121-261	Yellow	0.261
MS18121-275	Tin	0.275
MS18121-281	Purple	0.281
MS18121-287	Blue	0.287
MS18121-297	Green	0.297
MS18121-312	Yellow	0.312
MS18121-327	Tin	0.327
MS18121-348	Orange	0.348
MS18121-359	Purple	0.359
MS18121-375	Yellow	0.375
MS18121-405	Red	0.405
MS18121-415	Blue	0.415
MS18121-460	Tin	0.460
MS18121-500	Green	0.500

Conductor shield termination procedures (continued):

- f. Strip insulation to match the length of the shield prepared from the shield return wire in accordance with [figure 5A3](#).
- (1) The shield return shall be fabricated from insulated flexible stranded wire with the same physical characteristics as the conductor.
 - (2) When terminated to a connector contact, the wire size shall be governed by the contact to which it is being attached.
 - (3) The length shall allow the shield return wire to extend beyond the connector after attachment to the shield.
- g. Slide the outer ferrule back over the conductor outer jacket (if present) and braided shield (see illustration 5B).

FIGURE 5A7. Conductor shield termination procedures – Continued.

MIL-STD-2003-5B(SH)
APPENDIX 5A

Conductor shield termination procedures (continued):

- h. Rotate the conductor with a circular motion to flare out the braid (see illustration 5C).
 - i. Place the inner ferrule under the shield braid so that $\frac{1}{16}$ inch of sleeve sticks out beyond the braid (see illustration 5D).
 - (1) Ensure the shield return wire strands and shield braid strands are flat and smooth.
 - j. Insert the stripped end of the shield return wire under the outer ferrule and slide both forward over the shield braid and inner ferrule until flush with the braid and inner ferrule.

NOTE: The shield return wire may extend from the front (when terminating to a contact) or rear (when terminated to another shield) of the outer ferrule as required.
 - k. Select a crimper and dies meeting the requirements of SAE-AS22520/5 or SAE-AS22520/10.
 - (1) Test the crimping tool using an inspection gauge meeting the requirements of SAE-AS22520/6.
 - l. Place the ferrule assembly into the crimping tool, and crimp until the handle releases.
 - m. Visually inspect the crimped ferrule assembly for fractures or chipping. Ensure the integrity of the connection by giving the shield return wire a light finger tug. Reject any ferrules that do not meet the above criteria.
 - n. Terminate the shield return wire with other conductors in accordance with the applicable connector assembly procedure.
 - o. As an alternate to the step 5 method for shield return wire insertion under the outer ferrule, the following may be used:
 - (1) Before the inner ferrule is placed under the shield braid, insert shield return wire under the inner ferrule and fold back over as shown (see illustration 5H). This method is intended to prevent the shield return wire from pulling out prior to crimping of the ferrule.
 - (2) The note associated with step 5.j is also applicable to this method.
6. Tying back and insulation of shields:
- a. When system design does not require continuity of the conductor shield through a connector or to ground, the shield shall be terminated as follows:
 - (1) Strip the conductor insulation to the length required by the applicable connector assembly procedure in accordance with [figure 5A3](#).
 - (2) Trim the shield to a length of $\frac{3}{8}$ inch.
 - (3) Comb out the shield braid using a spudger.
 - (4) Fold the shield back over the conductor jacket. Ensure that the shield strands are flat and smooth.
 - (5) ~~Center a length of insulation sleeve over the folded back shield and shrink in place.~~
 - (a) Insulation sleeving shall meet the requirements of SAE-AS23053/5, class 1.
 - (b) The length shall be sufficient to completely cover the shield after shrinking.
7. Combining individual shields to common ground (daisy chain) (see illustration 6):

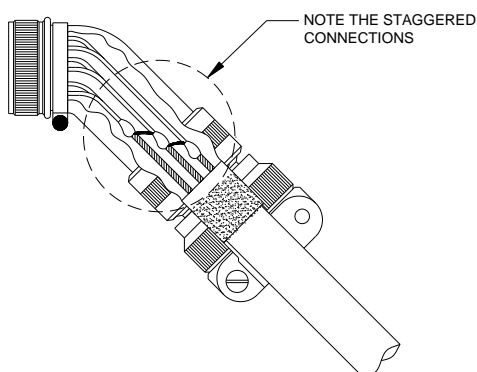

ILLUSTRATION 6
DAISY CHAIN NG SHIELD TERMINATIONS

FIGURE 5A7. Conductor shield termination procedures – Continued.

MIL-STD-2003-5B(SH)
APPENDIX 5A

Conductor shield termination procedures (continued):

- a. This procedure may be utilized when system wiring tables require more than one conductor shield to be attached to a common ground.
- b. Trim the shield of one conductor to $\frac{3}{8}$ -inch length (see illustration 7).
- c. Strip approximately $\frac{3}{8}$ inch of insulation from both ends of a flexible, stranded wire compatible with the connector contacts (see illustration 7).

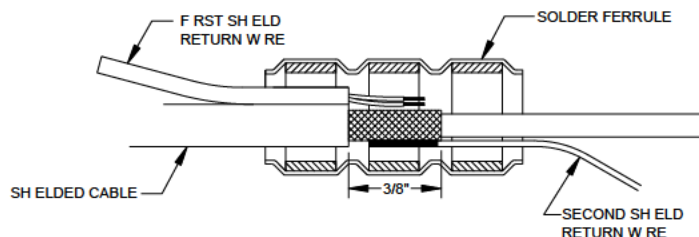

ILLUSTRATION 7
DAISY CHAIN SOLDER FERRULE JUNCTION

- (1) The length of the stranded wire shall suit the distances between the location of the two shielded conductors.
 - d. Tin both stripped ends of the wire in accordance with [figure 5A5](#).
 - e. Attach the wire to the shield using steps 4.e through 4.k.
 - f. Trim the shield of a second conductor to $\frac{3}{8}$ -inch length.
 - (1) Ensure the trimmed shields are staggered in length in order to avoid a buildup in one area.
 - g. Position the other stripped end of the first conductor against and parallel to the second exposed shielding.

NOTE: If more than two shields are to be connected together, ensure a second ground return wire is positioned next to the second shield and first ground return wire (see illustration 7).
 - h. Attach the wire to the shield using steps 4.e through 4.k.
 - i. Continue in this manner until all shields have been connected together and one shield return wire remains.
 - j. Terminate the shield return wire with other conductors in accordance with the applicable connector assembly procedure.
8. Individual shield termination to backshell:
- NOTE: Ensure leads/pairs are identified.
- a. Cut and remove conductor outer insulation as close to cable jacket as possible (see illustration 8A). Stagger as necessary to preclude excessive bulk.
 - b. Push conductor shield back until a bubble forms at jacket termination (see illustration 8B).
 - c. Insert a soft instrument, such as a spudger, into the shield bubble as close to the insulation termination as practicable (see illustration 8C).

NOTE: Do not damage underlying conductor insulation.
 - d. Move tool with a circular motion until a hole is formed large enough to pass the conductor through.

NOTE: Care should be taken not to break any shield strands.
 - e. Carefully bend the conductor and shield at the hole while inserting the soft instrument between the shield and conductor (see illustration 8D). Pull the conductors completely through the formed hole.

FIGURE 5A7. Conductor shield termination procedures – Continued.

MIL-STD-2003-5B(SH)
APPENDIX 5A

A. SCORE AND REMOVE THE JACKET AS SHOWN:



B. BUNCH THE BRAID

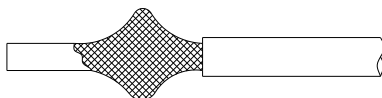

C. FORMATION OF HOLE

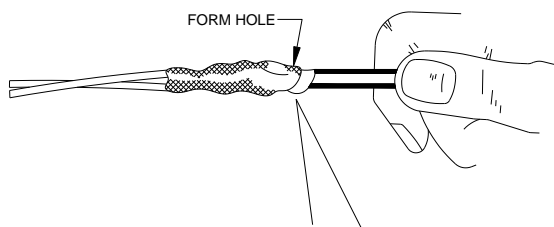

D. CONDUCTOR REMOVAL

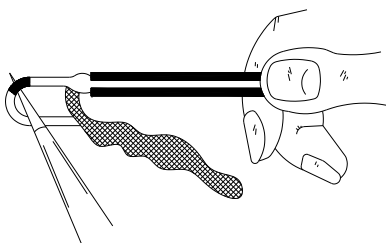

E. STRETCH BRAID

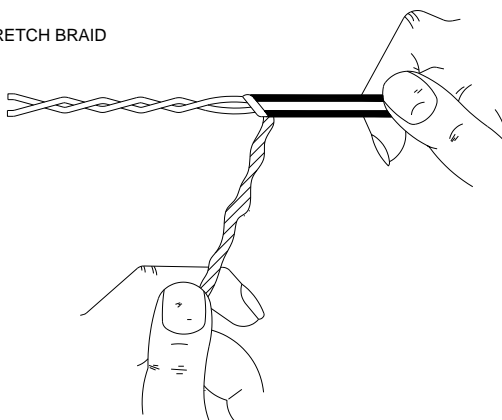

ILLUSTRATION 8
INDIVIDUAL SH ELD TERMINATION

Conductor shield termination procedures (continued):

- f. Stretch the empty section of shield and protect until closing (see illustration 8E).
- g. Proceed to step 5.i on [figure 5A8](#) of the gross shield termination procedure.

FIGURE 5A7. Conductor shield termination procedures – Continued.

MIL-STD-2003-5B(SH)
APPENDIX 5A

Gross shield termination procedures:

1. Observe the following before terminating the gross shield:
 - a. Verify that the shield braiding is not cut, nicked, or scratched.
 - b. Inspect all shield termination hardware (RFI rings, ferrules, etc.) to ensure they are the correct type and size, and are free of tarnish, corrosion, or damage.
2. Gross shield termination shall be in accordance with applicable system wiring tables and diagrams utilizing one of the methods outlined in this appendix.
3. Method 1 – Floating shield method:
 - a. This method is used when the system design does not require continuity of the shield through the connector or grounding of the shield.
 - b. Carefully comb out the shield using a spudger (see illustration 1).

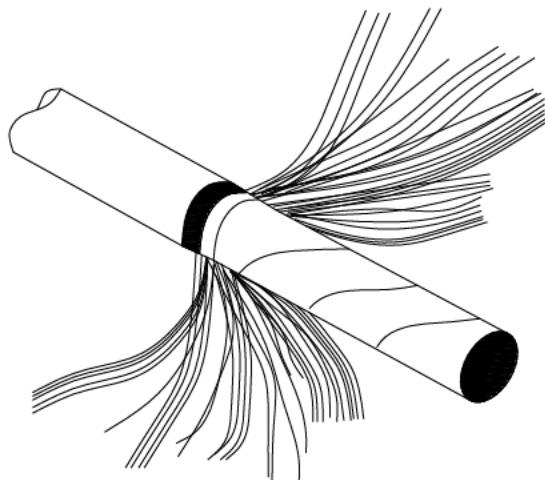

ILLUSTRATION 1
COMBED OUT GROSS SHIELD

- c. Separate the unbraided shield wires into three equal groups.
- d. Twist each group into a tight self-contained bundle (pigtail) (see illustration 2).

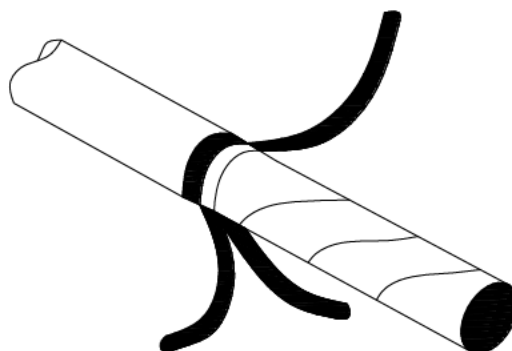

ILLUSTRATION 2
GROSS SHIELD PIGTAILS

FIGURE 5A8. Gross shield termination procedures.

MIL-STD-2003-5B(SH)
APPENDIX 5A

Gross shield termination procedures (continued):

- e. Cut the pigtails $\frac{3}{4}$ inch from the cable jacket (see illustration 3).
NOTE: Do not tin the pigtails. Leave for possible RFI hook-up at a later date.

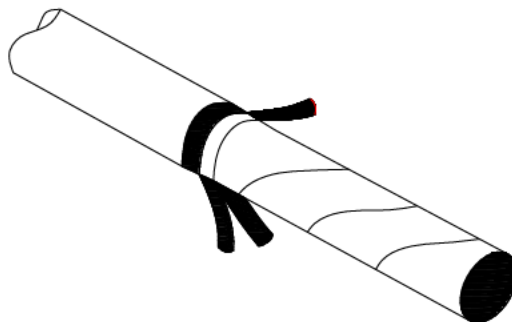

ILLUSTRATION 3
TRIMMED PIGTAILS

- f. Cover each pigtail with a 1-inch length of appropriately sized shrink sleeving conforming to SAE-AS23053/5, class 1 (see illustration 4).

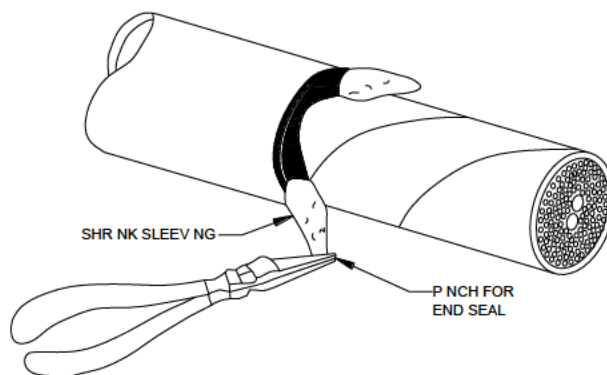

ILLUSTRATION 4
COVERING THE PIGTAILS

- g. Apply heat to shrink the sleeving. Pinch the ends of the shrink tubing shut as heat is applied to create an end seal (see illustration 4).
NOTE: When heating the shrink tubing, keep heat away from the cable as much as possible to prevent damaging the cable jacket and insulation.
- h. Trim the underlying Mylar wrap, leaving $\frac{1}{2}$ inch to protect the individual conductor insulation.
- i. Place a $\frac{3}{4}$ -inch length of shrink sleeving (diameter to exceed cable diameter) over the cable jacket and pigtails.
- j. Apply heat and shrink the sleeving prior to backshell assembly in the applicable connector assembly procedure (see illustration 5).

FIGURE 5A8. Gross shield termination procedures – Continued.

MIL-STD-2003-5B(SH)
APPENDIX 5A

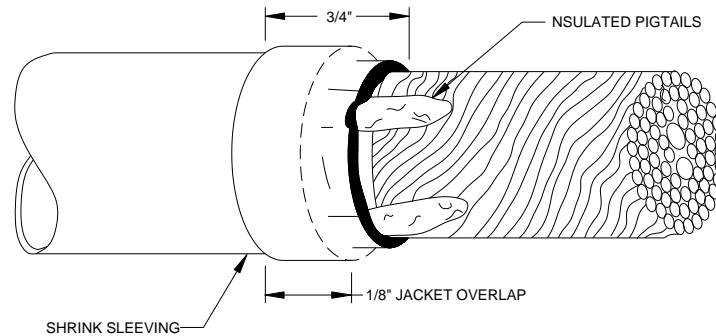

ILLUSTRATION 5
APPLICATION OF SHRINK SLEEVING

Gross shield termination procedures (continued):

4. Method 2 – Gross shield attached to connector contact:
 - a. Prepare the gross shield in accordance with steps 3.b through 3.h, ensuring one pigtail is left exposed for connection to the shield return wire.
 - b. Cut a length of shield return wire 2 inches longer than the exposed conductors.
 - (1) Shield return wires shall be fabricated from insulated, flexible, stranded type wire with the same physical characteristics as the shielded cable.
 - (2) The wire size shall be dictated by the contact to which it will be connected (see applicable wiring table and connector assembly procedure).
 - c. Strip $\frac{3}{4}$ inch of insulation from the shield return wire in accordance with [figure 5A3](#).
 - d. Terminate the shield return wire as follows:
 - (1) Butt the insulation to within $\frac{1}{16}$ inch of the cut end of the pigtail. Wrap the wire strands into the lay of the pigtail wire strands (see illustration 6).

FIGURE 5A8. Gross shield termination procedures – Continued.

MIL-STD-2003-5B(SH)
APPENDIX 5A

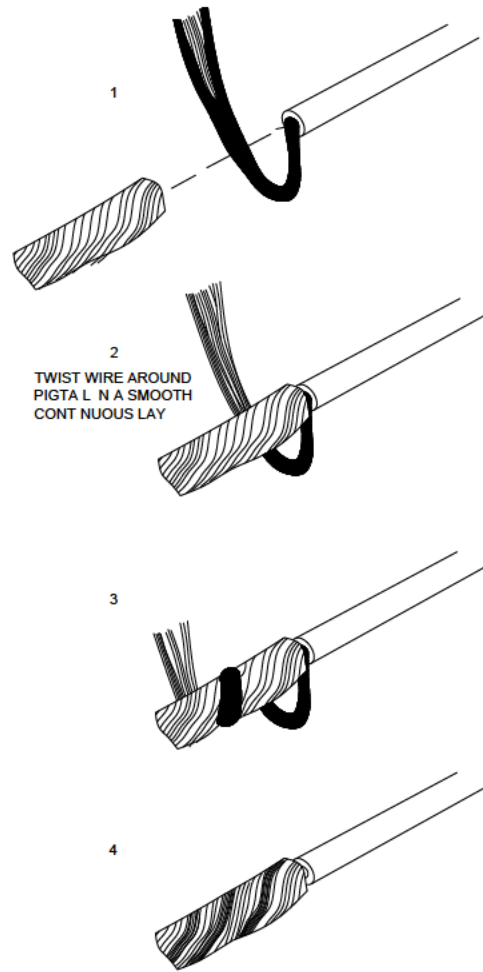

ILLUSTRATION 6
COMBINING SHIELD RETURN WIRE AND GROSS SHIELD PIGTAIL

FIGURE 5A8. Gross shield termination procedures – Continued.

MIL-STD-2003-5B(SH)
APPENDIX 5A

Gross shield termination procedures (continued):

- (2) Solder the shield return wire to the pigtail. The solder should appear continuous, smooth, and shiny with a concave fillet between strands. See [figure 5A6](#) for acceptance criteria.
 - (3) Clean the soldered connection with approved solvent.
 - (4) Cover the soldered connection with appropriately sized shrink tubing, conforming to SAE-AS23053/5 class 1, of sufficient length to cover the exposed shield and solder connection. Shrink the tubing, directing heat away from conductors to prevent damage.
- e. Strain relief:

- (1) Place a ½-inch length of appropriately sized shrink tubing over the tubing applied in step 4.d(4). Loop the shield return wire up through the shrink tubing to provide a strain relief for the shield return wire (see illustration 7). Caution: In order to provide the proper strain relief, the heat shrink shall not constrict the movement of the shield return wire.
- (2) Alternative method – Fold back the return wire and tie, forming a strain relief using the lacing.

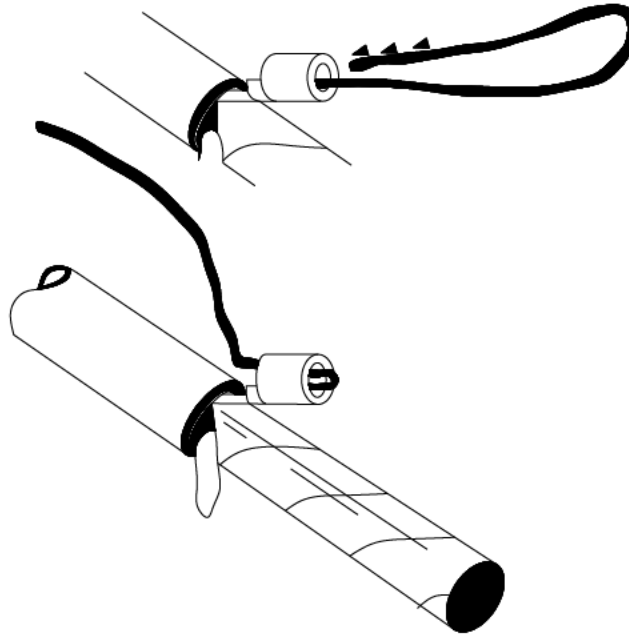

ILLUSTRATION 7
FORMING THE STRAIN RELIEF

FIGURE 5A8. Gross shield termination procedures – Continued.

MIL-STD-2003-5B(SH)
APPENDIX 5A

Gross shield termination procedures (continued):

- f. Place a ¾-inch length of shrink sleeving (diameter to exceed cable diameter) over the cable jacket and pigtails.
- g. Apply heat and shrink the sleeving prior to backshell assembly in the applicable connector assembly procedure.
- h. Terminate the shield return wire with other conductors in accordance with the applicable connector assembly procedure.

5. Method 3 – Gross shield grounded to backshell (see illustration 8):

NOTE: The following assembly procedure is based on the nomenclature and hardware configuration depicted in illustration 8. Variations may occur and cause minor deviation from this procedure.

- a. Carefully comb out the gross shield using a soft instrument, such as a spudger.
- b. Assemble sleeve assembly (PC 2) to the connector plug (PC 1) and tighten.
- c. Measure the distance from the connector end to the aft end of the sleeve assembly.
- d. Remove the sleeve assembly and reposition on the cable in a location that will not interfere with subsequent connector assembly.
- e. Trim the shield to the distance measured in step 5.c.
- f. Complete all steps in the applicable connector assembly procedure up to the backshell assembly section.
- g. Measure the distance from the connector aft end to the cable jacket.
- h. Measure the distance from the forward end of the sleeve assembly to a point midway on the taper of the inner ferrule (RFI bell). The inner ferrule shall be bottomed against the sleeve shoulder.
- i. Determine the desired length of the gross shield by subtracting the measurement of step 5 h from the measurement of step 5.g.
NOTE: Ensure gross shield pieces do not fall into the connector during trimming.
- j. Trim the gross shield to the desired length.
- k. Assemble sleeve assembly (PC 2) to the connector plug (PC 1) and tighten. (See applicable connector assembly procedure.)
- l. Slide inner ferrule (RFI bell) (PC 3) into sleeve assembly and seat on inner shoulder.
- m. If the applicable wiring tables call for individual conductor shields to be grounded to the backshell, push the shields through the gross shield close to the end of the cable jacket and combine individual shield strands with the gross shield.
- n. Flare the gross shield over the tapered end of the inner ferrule.

FIGURE 5A8. Gross shield termination procedures – Continued.

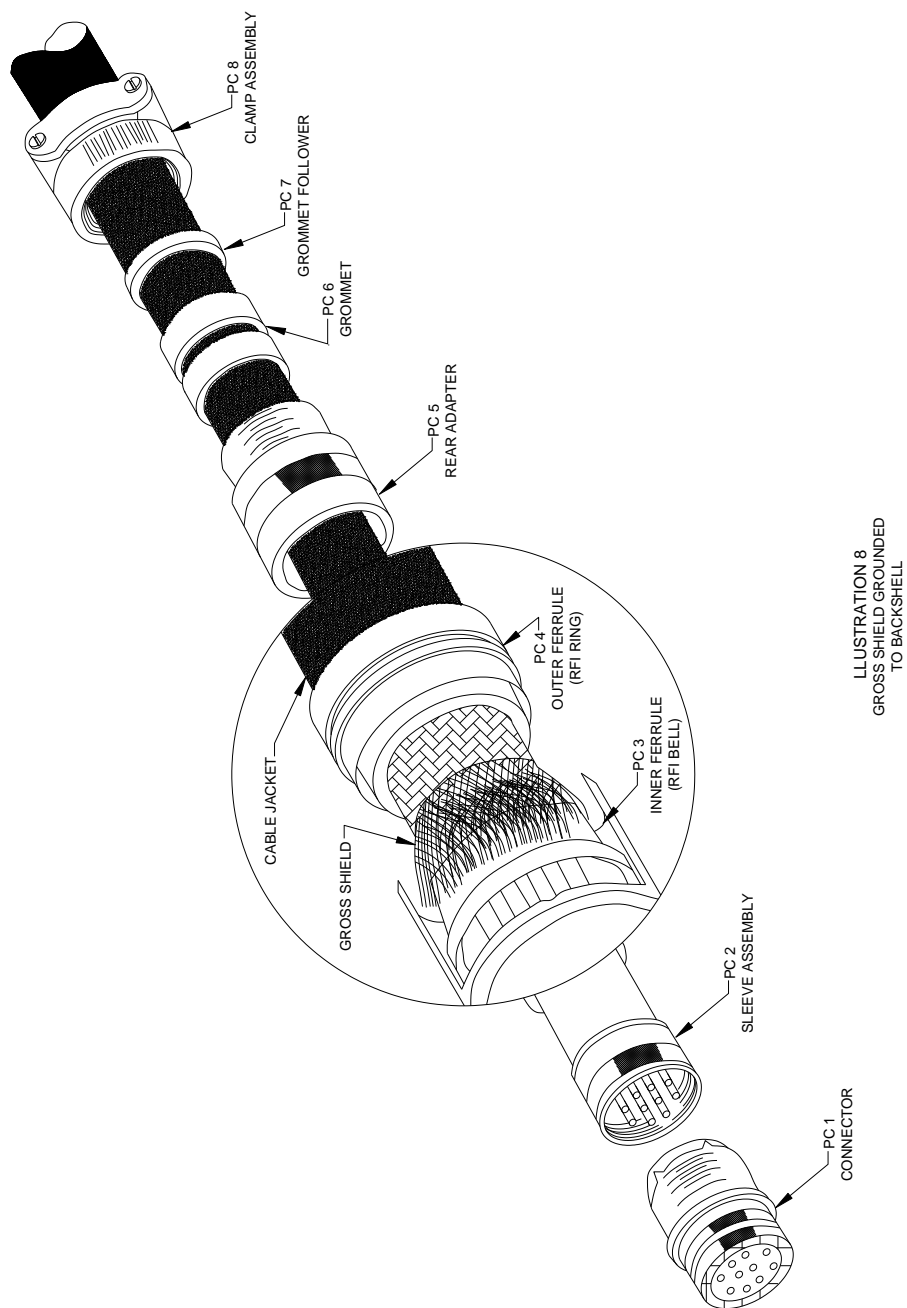
MIL-STD-2003-5B(SH)
APPENDIX 5A**Gross shield termination procedures (continued):**

- o. Gently force the cable toward the connector plug until the shield covers the tapered surface of the inner ferrule.
- p. Insert the outer ferrule (RFI ring) (PC 4) into the sleeve assembly while applying forward pressure on the cable.
- q. Assemble the remaining backshell components in accordance with the applicable connector assembly procedure.

FIGURE 5A8. Gross shield termination procedures – Continued.

MIL-STD-2003-5B(SH)
APPENDIX 5A

Connector lockwiring techniques:

1. The following practices shall be observed when lockwiring connectors:
 - a. Connectors shall be lockwired with 0.020-inch diameter wire conforming to NASM20995.
 - b. Connectors shall be lockwired individually.
 - c. Lockwire shall not be reused.
 - d. Damaged lockwire shall not be used.
 - e. Backshells with holes in the coupling ring shall be lockwired.
2. Connectors shall be lockwired when using 45-degree or 90-degree adapter assemblies (backshells) to prevent the loosening of the adapter coupling ring (see illustration 1).

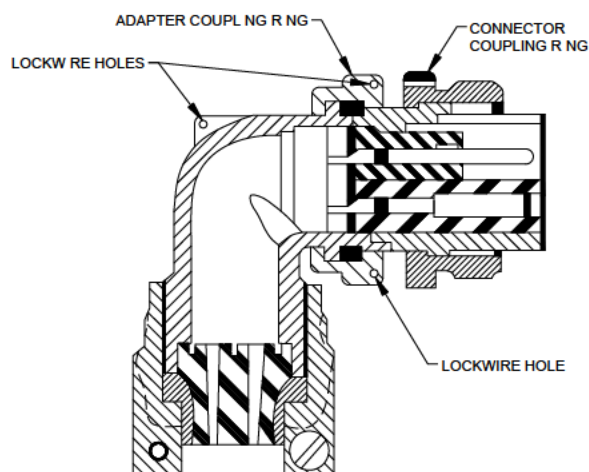

ILLUSTRATION 1
LOCATION OF LOCKWIRE

3. Lockwire is not required if the coupling nut has set screws or other self-locking provisions.
4. The following procedure shall be used to lockwire connectors (see illustration 2):
 - a. The parts shall be lockwired using a double twist in such a manner that when the coupling collar loosens, the lockwire shall be put in tension.

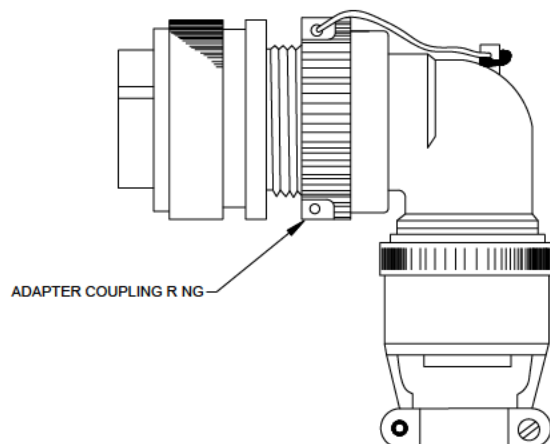

ILLUSTRATION 2
LOCKWIR NG THE CONNECTOR

FIGURE 5A9. Connector lockwiring.

MIL-STD-2003-5B(SH)
APPENDIX 5A

Connector lockwiring techniques (continued):

- b. When the backshell does not have a hole provided and there is no other provision for maintaining backshell/connector orientation, a CRES hose clamp, A-A-52506, type F, should be installed to secure the lockwire as depicted in illustration 3.

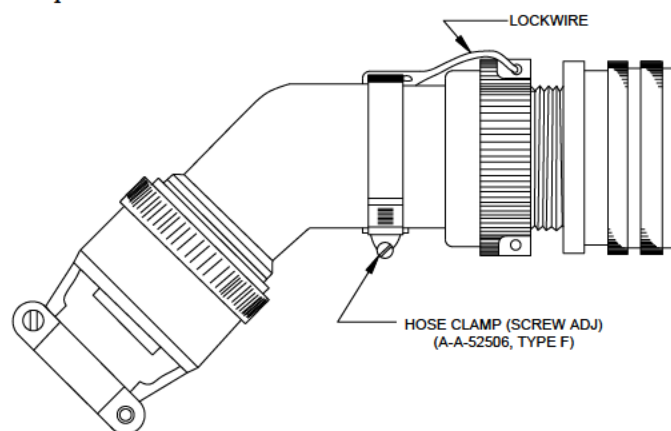

ILLUSTRATION 3
USING A HOSE CLAMP

- c. Measure the distance from the adapter coupling ring safety hole to backshell tab (or hose clamp) and add 2 inches.
- d. Cut the lockwire twice the total dimension measured in step 4.c.
- e. Thread the lockwire through the selected adapter coupling ring hole. Pull ends together to even out the legs of lockwire.
- f. Twist lockwire from adapter coupling ring hole to backshell safety tab (or hose clamp) forming 6 to 8 turns per inch.
- g. Thread one lockwire through the backshell lockwire tab (or hose clamp) and pull tight.
- h. Twist the remaining lockwire. Cut off the extra lockwire leaving a pigtail of $\frac{1}{4}$ inch to $\frac{1}{2}$ inch (3 to 6 twists) and bend back or under to prevent it from becoming a snag.
- (1) Ensure the lockwire is installed and twisted so that the loop at the safety holes stays down and does not tend to come up over the hole and leave a slack loop (see illustration 3).
- i. When optional extensions are used, the coupling nut on the optional extension shall also be secured by lockwire.
- j. If the clamp assembly has a safety wire hole installed, install lockwire between it and the adapter assembly (see illustration 4).
- k. Ensure the hose clamp (if present) is securely tightened (see 4.5).

FIGURE 5A9. Connector lockwiring – Continued.

MIL-STD-2003-5B(SH)
APPENDIX 5A

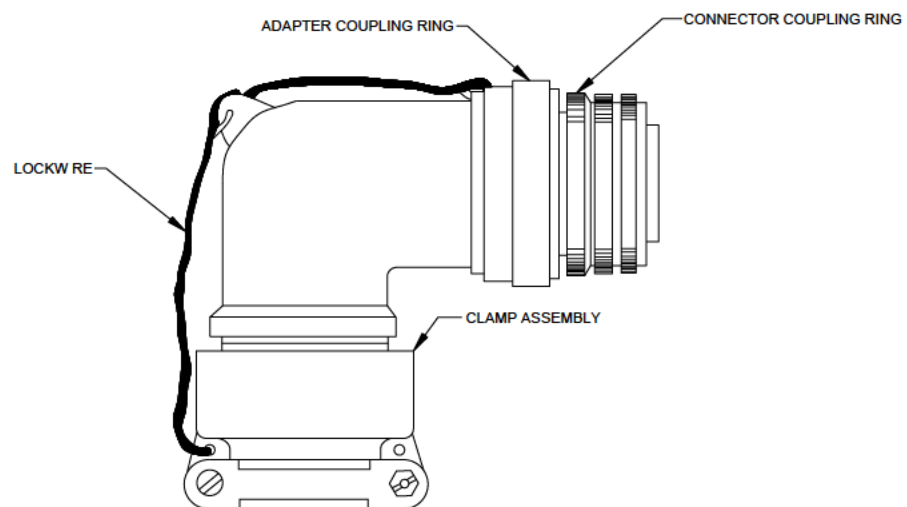

ILLUSTRATION 4
LOCKWIRING THE CLAMP ASSEMBLY

FIGURE 5A9. Connector lockwiring – Continued.

MIL-STD-2003-5B(SH)
APPENDIX 5A**Cable transflexing procedure:**

1. Cable transflexing should be accomplished only after approval has been granted by NAVSEA.
2. The purpose of transflexing a cable is to allow the cable to exceed the minimum bend radius requirement and still provide a measure of mechanical and environmental protection to the individual conductors.
3. Cables shall be transflexed in accordance with the following procedure (see illustration 1).
 - a. Perform steps 1 and 2 of the applicable connector assembly procedure. Do not proceed beyond step 5 of cable preparation ([figure 5A1](#)).
 - b. Determine the length of cable to be transflexed. The length shall not exceed the distance as measured from the cable end to the point where the cable breaks out of its last hanger (18 inches maximum).
 - c. If the cable is armored, remove the armor 1½ inches beyond the length determined in step 3.b using an appropriate cable stripper. This ensures the armor will not interfere with the environmental seal between the cable jacket and transflex sleeving.
 - (1) Install a ½-inch piece of heat shrink sleeving centered over the armor/jacket junction and shrink in place.
 - (a) Heat shrinkable sleeving shall meet the requirements of SAE-AS23053/5, class1.
 - d. Remove the cable jacket to the predetermined length as follows:

NOTE: Ensure the cut does not completely penetrate the jacket.

 - (1) Score the circumference of the jacket with a multi-purpose cutter (OLFA 300 or equal, see 4.2).
 - (2) Score the jacket piece to be removed along its length with a multi-purpose cutter.
 - (3) Remove the jacket piece with needle nose pliers.
 - e. Do not damage gross shield (if applicable) or conductor insulation.
 - f. Provide a length of heat shrinkable sleeving conforming to SAE-AS23053/5, class 1 of the proper diameter (see [table 5A10-I](#)) that will cover the cable conductors, ensuring the following:

FIGURE 5A10. Cable transflexing procedure.

MIL-STD-2003-5B(SH)
APPENDIX 5A

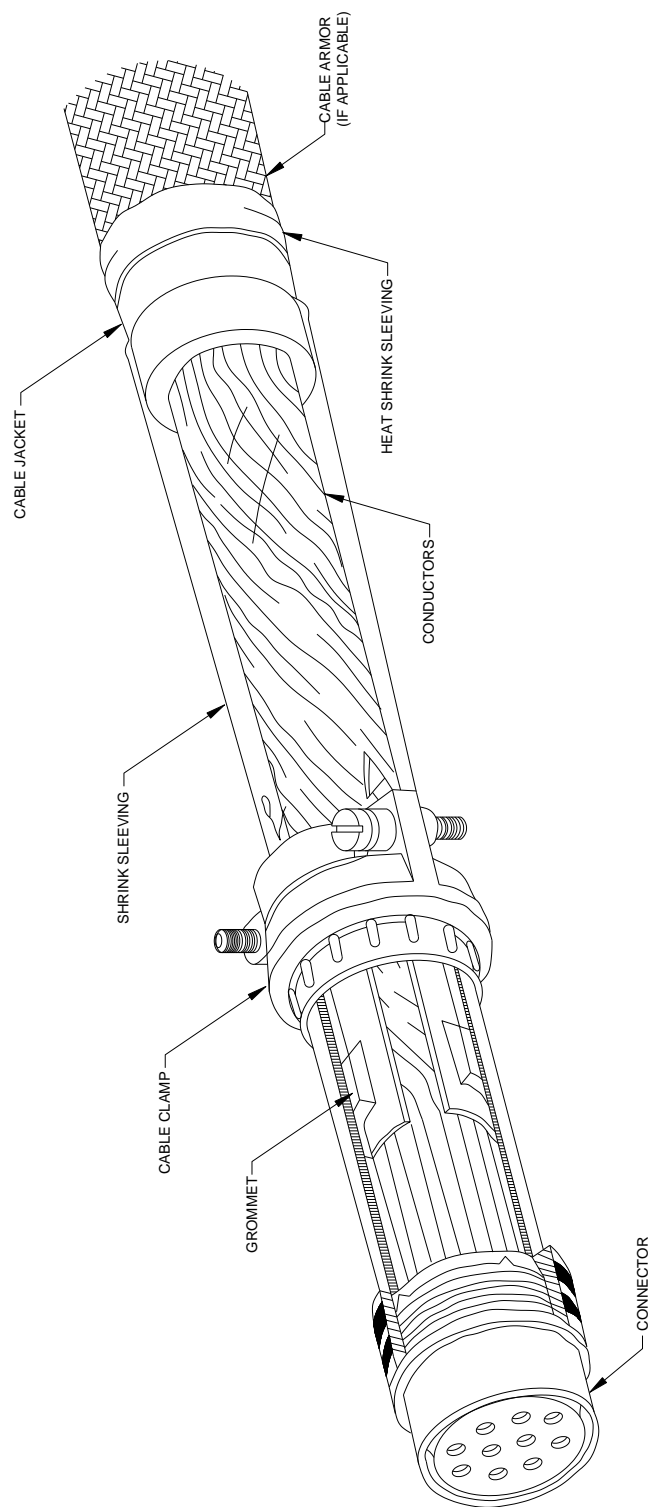

ILLUSTRATION 1
CABLE TRANSFLEXING

FIGURE 5A10. Cable transflexing procedure – Continued.

MIL-STD-2003-5B(SH)
APPENDIX 5A

Cable transflexing procedure (continued):

- (1) A minimum of 1 inch of overlay at the cable jacket.
- (2) Sleeving extends past the sealing gland in the backshell when the backshell is mated to the connector.

NOTE: Ensure longitudinal shrinkage is taken into consideration when making the above determination.

- g. Cut and remove any filler or core used to make up the cable construction.

NOTE: If the gross shield interferes with this step, push the braided shield back on the cable as depicted in illustration 2, while removing cable fillers.

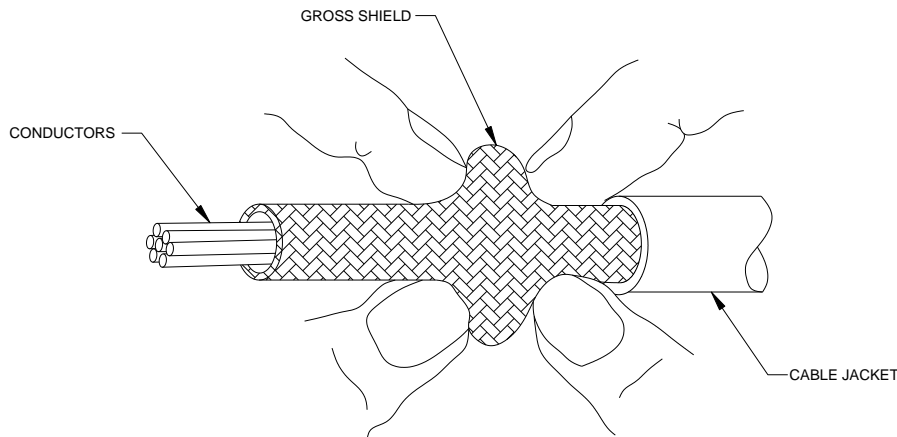

ILLUSTRATION 2
GROSS SHIELD INTERFERENCE REMOVAL

- h. Shrink a test piece of tubing over exposed conductors to check clamping and environmental sealing in accordance with [figure 5A1](#) (steps 6 and 8).
 - (1) Build up the cable diameter in accordance with [figure 5A2](#) if necessary.
- i. Remove the test piece of tubing. Assemble the backshell and clamp components on the cable so as not to interfere with subsequent steps.
- j. Slide the tubing selected in step 3.f over the exposed conductors onto the cable out of the work area.
- k. Hold exposed conductors and gross shield together with temporary ties.

FIGURE 5A10. Cable transflexing procedure – Continued.

MIL-STD-2003-5B(SH)
APPENDIX 5A

TABLE 5A10-I. Heat shrink tubing (SAE-AS23053).

Military part number	I.D. min. (as supplied)	After unrestricted shrinkage	
		I.D. max.	Wall thickness
Class 1			
M23053/5-101 ^{1/}	0.046	0.023	0.016±0.003
102 ^{1/}	0.063	0.031	0.017±0.003
103 ^{1/}	0.093	0.046	0.020±0.003
104 ^{1/}	0.125	0.062	0.020±0.003
105 ^{1/}	0.187	0.093	0.020±0.003
106 ^{1/}	0.250	0.125	0.025±0.003
107 ^{1/}	0.375	0.187	0.025±0.003
108 ^{1/}	0.500	0.250	0.025±0.003
109 ^{1/}	0.750	0.375	0.030±0.003
110 ^{1/}	1.000	0.500	0.035±0.005
111 ^{1/}	1.500	0.750	0.040±0.006
112 ^{1/}	2.000	1.000	0.045±0.007
113 ^{1/}	3.000	1.500	0.050±0.008
114 ^{1/}	4.000	2.000	0.055±0.009
Class 1 overexpanded			
M23053/5-115 ^{1/}	1.000	0.275	0.045±0.005
116 ^{1/}	2.000	0.550	0.045±0.005
117 ^{1/}	3.000	0.810	0.045±0.005
118 ^{1/}	4.000	1.050	0.045±0.005
119 ^{1/}	1.000	0.462	0.045±0.005
120 ^{1/}	2.375	0.680	0.045±0.005
121 ^{1/}	3.000	0.840	0.045±0.005
122 ^{1/}	3.750	0.930	0.045±0.005
123 ^{1/}	4.500	1.450	0.045±0.005

NOTE:

^{1/} Select color designators are as follows:

Designator	Color
0	Black
1	Brown
2	Red
3	Orange
4	Yellow
5	Green
6	Blue
7	Violet (purple)
8	Gray (slate)
9	White
P	Pink
T	Tan

FIGURE 5A10. Cable transflexing procedure – Continued.

MIL-STD-2003-5B(SH)
APPENDIX 5A

Cable transflexing procedure (continued):

- l. Disassemble and relocate the backshell and clamp components on the cable. Verify that all parts are included and are in correct order and orientation. Assemble the backshell, and locate it on the cable so that it will not interfere with connector wiring.
- m. Continue assembling the connector in accordance with the applicable connector assembly procedure commencing with step 12 of [figure 5A1](#).

NOTE: Terminate the gross shield (if applicable) inside the backshell forward of and not to interfere with the environmental seal.

NOTE: Do not assemble the backshell to the connector until sequenced in this procedure.

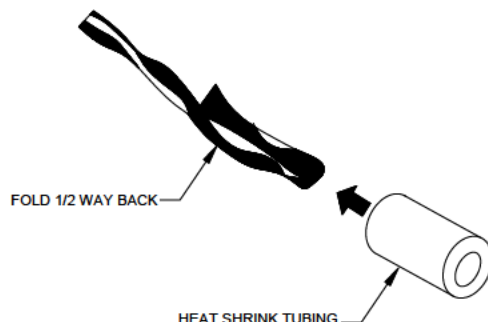

ILLUSTRATION 3
TERMINATION OF SPARE CONDUCTORS

- n. Fold spare conductors back and insulate exposed ends with a ½-inch length of heat shrink tubing (see illustration 3).
 - (1) Position grommet follower if applicable.
- o. If connector has individual lead sealing grommet, slide down over conductors and seat.
 - (1) Clean the area with an approved solvent from [table 5A10-II](#).

FIGURE 5A10. Cable transflexing procedure – Continued.

TABLE 5A10-II. Approved solvents.

Solvent	Specification
Isopropyl alcohol	TT-I-735
Perchloroethylene	ASTM D4376
Reagent water (type II)	ASTM D1193
Detergent cleaners	As approved by the Government procuring activity

Cable transflexing procedure (continued):

- p. Abrade bonding surface of cable jacket with #320 emery cloth or equivalent (see illustration 4).

MIL-STD-2003-5B(SH)
APPENDIX 5A

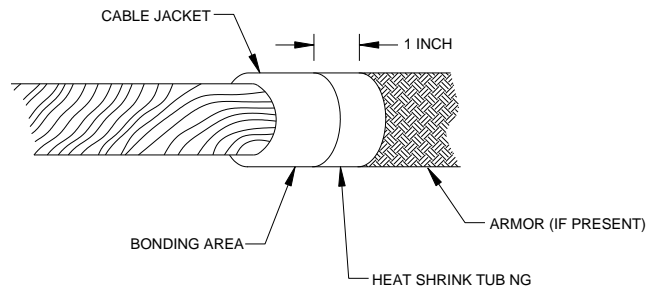

ILLUSTRATION 4
CABLE JACKET PREPARATION

- q. Apply adhesive to the abraded area of the cable jacket.
 - (1) Adhesive material shall be of a type that will effectively seal the enclosed area against moisture (general purpose adhesive MMM-A-189).
- r. Remove the temporary ties applied in step 3.k and position the heat shrinkable tubing over the cable conductors, ensuring that the tubing overlaps the cable jacket by 1 inch and completely covers the environmental seal area. It will be necessary to use a heat gun to shrink the tubing sufficiently to pass the shrinkable tubing under the backshell components during positioning.
- s. Position the backshell components away from the connector end, and using a heat gun, shrink the tubing starting at the connector end. When clear of the area that will be occupied by the backshell, slide the backshell components to the connector end.
- t. ~~Continue applying heat in the direction of the cable jacket, removing heat as the sleeving assumes the configuration of the cable conductors.~~
- u. When the sleeving has recovered sufficiently to seal with the cable jacket and excess adhesive appears at the end, discontinue the heating process.

CAUTION: Do not use solvent for cleaning off excess adhesive. Doing so could cause migration of the solvent into the bond line area and result in a potential bond failure.
- v. Wipe off excess adhesive with a clean cloth.
- w. Assemble the backshell components to the connector in accordance with the applicable connector assembly procedure.

FIGURE 5A10. Cable transflexing procedure – Continued.

MIL-STD-2003-5B(SH)
APPENDIX 5A

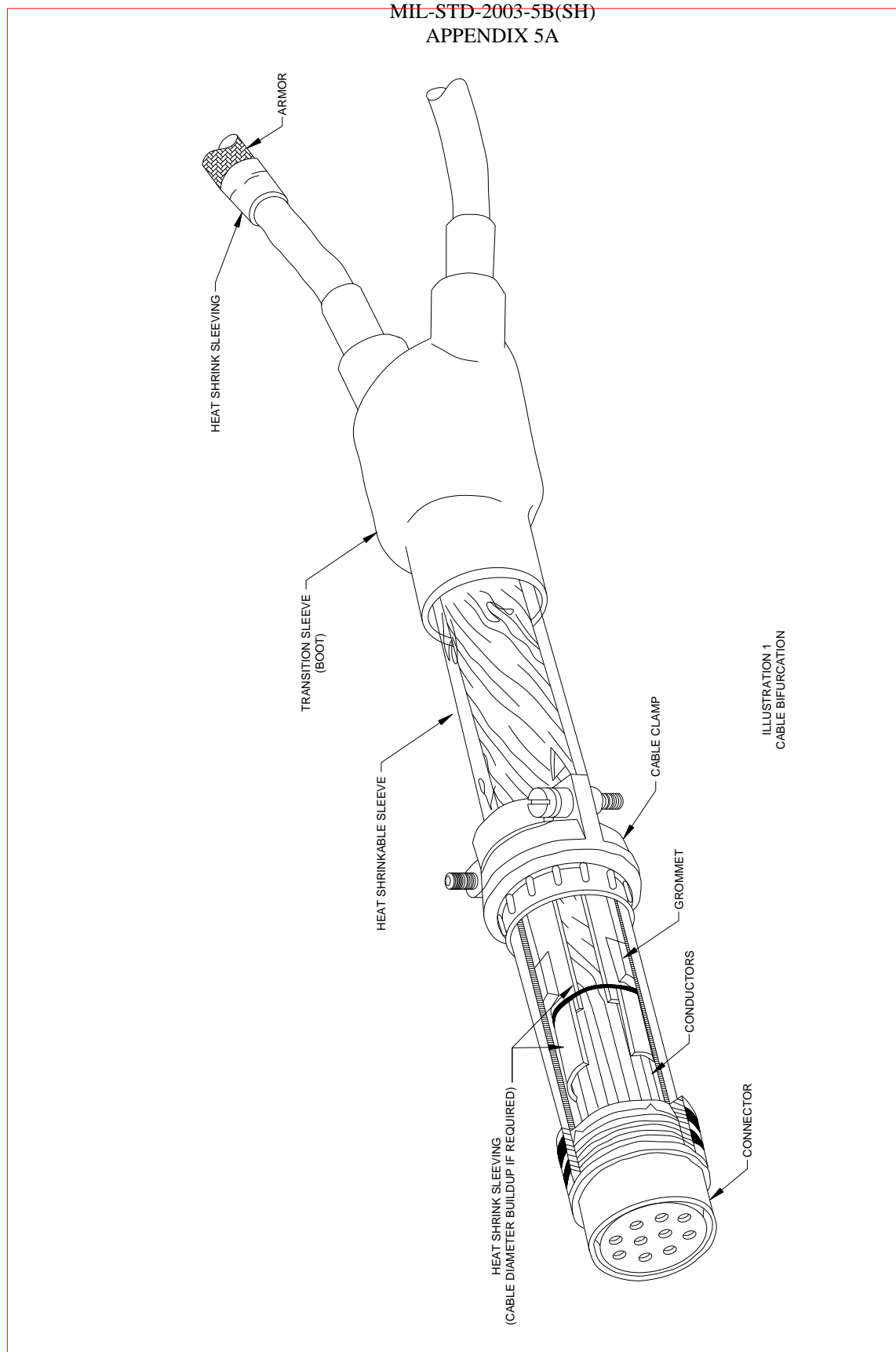

FIGURE 5A11. Cable bifurcation procedure.

MIL-STD-2003-5B(SH)
APPENDIX 5A

Cable bifurcation procedure:

1. Cable bifurcation in this procedure is the mating of two or three cables with a single connector. Mating of three cables shall use the methods and limitations in this procedure, which shows methods and figures for mating two cables. Mating of more than three cables to one connector using this procedure is not allowed without NAVSEA approval. This procedure shall ensure that an environmental seal exists and that adequate strain relief is provided (see illustration 1).
2. The procedure for mating two cables shall be as follows:
 - a. Determine the length from the connector where the mating of the two cables will occur.
 - (1) This distance shall not exceed the distance to the breakout of the two cables from their last wireway hanger (18 inches maximum).
 - b. Prepare each cable in accordance with [figure 5A1](#), steps 1 through 5.
 - c. Remove the cable jacket of each cable in accordance with [figure 5A1](#), step 9.d, to the point of juncture of the two cables.
 - (1) If one or both of the cables is armored, remove the armor from the cables(s) at a point 2 inches beyond the point of juncture using a cable stripper.
 - (2) Shrink a 1-inch piece of heat shrinkable tubing meeting the requirements of SAE-AS23053/5, class 1, centered at the end of the armor to terminate the armor on the cable jacket.
 - (3) Do not damage gross shield or conductor insulation.

- d. Cut and remove any filler or core used to make up the cable construction.
NOTE: If the gross shield interferes with this step, push the braided shield back on the cable as depicted in illustration 2 while removing cable fillers.

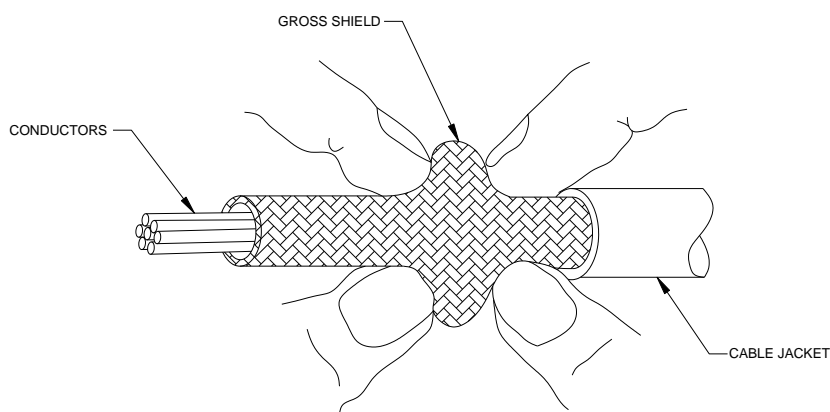

ILLUSTRATION 2
GROSS SHIELD INTERFERENCE REMOVAL

- e. Determine the diameters of the two cables to be bifurcated and the resultant wire bundle and select the appropriately sized "Y" transition sleeve (boot).
 - (1) Material for the boot shall be polyolefin, semi-rigid, non-burning, and shall conform to the requirements of SAE-AS81765/1. The boot shall have an internal coating of adhesive.
 - (2) If one boot will not fit the cables at all legs, select a size that fits as many legs as possible and is too large for the remaining legs. The cable(s) shall then be built up to the proper diameter (see [figure 5A2](#)) with adhesive-coated heat shrinkable tubing conforming to SAE-AS23053/15, class 1.
- f. Slide the legs of the boot over the cables and position away from the work area.
- g. Carefully comb out the gross shield using a soft instrument, such as a spudger, to junction of the two cables.
- h. Mark all conductors.
- i. Interweave the leads from both cables to form a single cable. The conductors of the combined cable shall exhibit the same lay (clockwise or counterclockwise rotation) and relative position as the original single cable conductors.

FIGURE 5A11. Cable bifurcation procedure – Continued.

MIL-STD-2003-5B(SH)
APPENDIX 5A

Cable bifurcation procedure (continued):

- j. Provide a length of heat shrink sleeving meeting the requirements of SAE-AS23053/5, class 1, of proper diameter to cover the combined bundle.
 - (1) Sleeving shall extend from a minimum of 1 inch under the boot to fit completely through connector sealing grommet (see illustration 1 and illustration 3 [figure 5A11]).
NOTE: Ensure longitudinal shrinkage is taken into consideration when making the above determination.
 - (2) Shrink a test piece of sleeving over conductor bundle to check clamping and environmental sealing in accordance with figure 5A1 (steps 6 and 8).
 - (3) Build up the cable diameter (in accordance with figure 5A2), if necessary, after removal of the test piece of sleeving.
- k. Position the tubing over the cables away from the working area. Assemble the backshell and clamp components on the cable so as not to interfere with subsequent steps.
- l. Continue assembling the connector in accordance with the applicable connector assembly procedure commencing with step 12 of figure 5A1.
NOTE: Do not assemble the backshell until sequenced in this procedure.
- m. Terminate gross shield internal to the backshell forward of (not to interfere with) environmental seal in accordance with applicable method of figure 5A8.
- n. Abrade the bonding surface of each cable jacket.
- o. Wipe the abraded surface with a solvent from table 5A11-I.

TABLE 5A11-I. Solvents.

Solvent	Specification
Isopropyl alcohol	TT-I-735
Perchloroethylene	ASTM D4376
Reagent water (type II)	ASTM D1193
Detergent cleaners	As approved by the Government procuring activity

- p. Assemble the sleeve assembly and tighten appropriately (see 4.5).
- q. Using a heat gun, shrink the sleeving by applying heat starting at the connector end. As the tubing shrinks, slide the tubing under the clamp and into the backshell, forward of the environmental sealing area.
- r. Continue applying heat in the direction of the cable jacket, removing heat as the sleeving assumes the configuration of the cable.
- s. Proceed with connector/backshell assembly in accordance with the applicable assembly procedure.
 - t. Slide the boot over the cable junction. Ensure the boot crotch is positioned so that the boot will overlap each cable jacket 1 inch.
- u. Shrink the boot with a heat gun by applying heat from the center to the ends to avoid trapping air.
 - (1) When the boot is recovered sufficiently to assume the configuration covered, remove the heat.
CAUTION: Do not use solvent for cleaning off excess adhesive. Doing so could result in migration of the solvent in the bond line area and result in a potential bond failure.
 - (2) Wipe off excessive adhesive with a clean cloth.
- v. Do not disturb junction until cool.

FIGURE 5A11. Cable bifurcation procedure – Continued.

MIL-STD-2003-5B(SH)
APPENDIX 5A

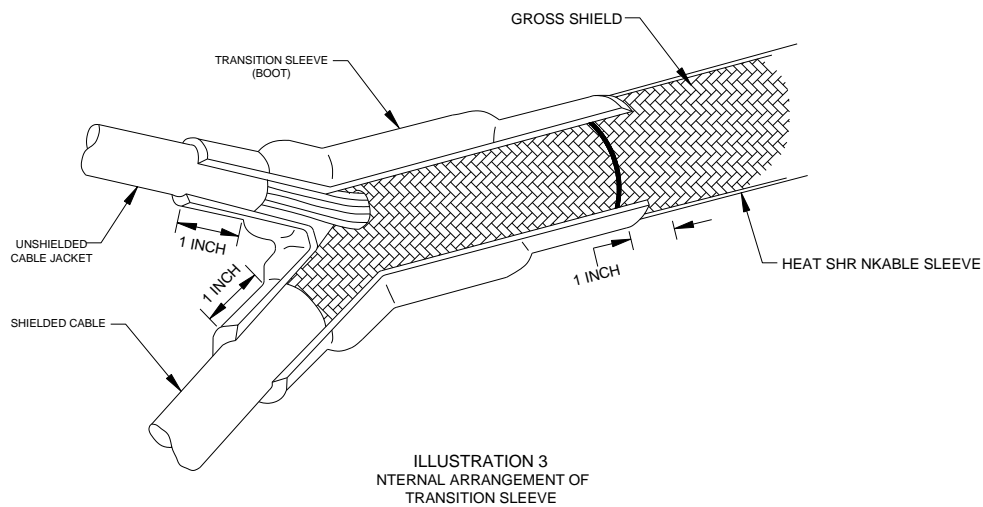

FIGURE 5A11. Cable bifurcation procedure – Continued.

MIL-STD-2003-5B(SH)
APPENDIX 5A

Glossary of terms used in this procedure:

1. A list of terms used in this procedure that are commonly used in electrical connector engineering practice follows.
 - a. Connector related terminology:
 - (1) Adapter – an intermediate device to provide for attaching special accessories or to provide special mounting means.
 - (2) Backshell assemblies – a device added between the rear of the connector and the cable clamp. The backshell is used to provide environmental sealing, RFI shielding, and conductor contact strain relief. Backshells are normally straight (0 degrees) or angled (45 or 90 degrees).
 - (3) Bayonet coupling ring – a positioning device for mating connectors utilizing keys on a connector and slots on the mating receptacle. Mating and unmating is accomplished by rotating the coupling ring.
 - (4) Basic Identification Number (BIN) code – a distinctive number assigned to identify the contact. The BIN code is indicated on the contact by three color-coded marking bands. The color-coded bands are normally located on the wire barrel end of the contact. The wider band, normally nearest the wire barrel end, indicates the first digit, the middle band indicates the second digit, and the last band indicates the third digit of the BIN code. The color code is:

0. Black	4. Yellow	7. Violet
1. Brown	5. Green	8. Gray
2. Red	6. Blue	9. White
3. Orange		
 - (5) Braid – a flexible conductor made of a woven or braided assembly of fine wires.
 - (6) Cable clamp – the cable clamp, when screwed onto the backshell, provides the compression force to seal the cable jacket to the backshell via the compression ring and gland. When tightened, the screws on the clamping bar provide mechanical holding of the cable to the backshell so the seal is not fractured by movement of the cable.
 - (7) Clocking – the orientation of cables having angled backshells to the master key of the mating receptacle.
 - (8) Connector barrel (wire barrel) – the section of the terminal splice or contact that accommodates the stripped conductor.
 - (9) Connector, electrical – a device, either a plug or a receptacle, used to terminate or connect the conductors in cables, and which provides a means to continue the conductors to a mating connector or printed circuit board.
 - (10) Contact – the conductive element in a connector that makes actual contact for the purpose of transferring electrical energy.
 - (11) Contact arrangement – the number, spacing, and arrangement of contacts in a connector.
 - (12) Contact engaging and separating force – force needed to either engage or separate contacts to mating contacts or gauge pins.
 - (13) Contact retainer – a device either on the contact or in the insert to retain the contact in an insert or body.
 - (14) Contact retention – the axial load in either direction that a contact can withstand without being dislodged from its normal position within an insert or body.
 - (15) Contact size – an assigned number denoting the size of the contact engaging end.
 - (16) Cover, electrical connector (dust cap) – an item which is specifically designed to cover the mating-end of a connector for mechanical protection, environmental protection, or both.
 - (17) Dummy connector receptacle – a specially designed connector receptacle that does not have provisions for attaching conductors. It is generally used for assembly of a counterpart connector plug.
 - (18) Extraction tool – a device used for removing removable contacts from a connector.

FIGURE 5A12. Glossary of terms.

MIL-STD-2003-5B(SH)
APPENDIX 5A

Glossary of terms used in this procedure (continued):

- (19) Guide pin – a specially designed pin inserted through a connector to guide socket contacts into proper insert cavity.
 - (20) Insert, electrical connector – an insulating element (dielectric) designed to position and support contacts in a connector.
 - (21) Insertion tool – a device used to insert contacts into a connector; a device used to insert taper pins into taper pin receptacles.
 - (22) Keying (polarization) – a mechanical arrangement of inserts and shell configuration, which prohibits the mating of mismatched plugs and receptacles. Alternate key arrangements are available to prevent mismatching of similar connectors.
 - (23) Plug connector – see electrical connector.
 - (24) Pull-out force – the force necessary to separate a conductor from a contact or terminal, or a contact from a connector, by exerting a tensile force.
 - (25) Radio Frequency Interface (RFI) pieces – the RFI pieces allow connection of the cable gross shield to the connector shell to provide a continuous RFI shield.
 - (26) Shell, electrical connector – the outside case of a connector into which the dielectric material and contacts are assembled.
 - (27) Sleeve – the sleeve is the outer housing of the backshell assembly; the sleeve normally contains the environmental sealing and RFI shielding components of the backshell. On angled backshells, the sleeve is formed at a 45- or 90-degree angle.
 - (28) Solder cup – the end of a terminal or contact in which the conductor is inserted prior to being soldered.
 - (29) Threaded coupling ring – a threaded ring fitting over the connector shell that threads onto the ring. The threaded coupling ring aides in mating the connector to the plug and holds the connector and plug in a mated condition.
 - (30) Wire-sealing plug – for environmental connectors, wire-sealing plugs are inserted behind contacts in unused connector holes to provide an environmental seal. Wire-sealing plugs are not required for non-environmental connectors.
- b. Crimping related terminology:
- (1) Crimp – the physical compression (deformation) of a contact barrel around a conductor in order to make an electrical connection.
 - (2) Crimping – a pressure method of mechanically securing a terminal, splice, or contact to a conductor.
 - (3) Crimping dies – portion of the crimping tool that shapes the crimp.
 - (4) Crimping tool – mechanism used for crimping.
 - (5) Depth of crimp – the distance the indenter penetrates into the barrel.
 - (6) Indenter – that part of a crimping tool, usually the moving part, that compresses indentations in the contact conductor barrel.
 - (7) Locator – the part of the crimping die, positioner, or turret head that places the terminal, splice, or contact in the correct crimping area of the crimping tool or die.
 - (8) Positioner – see locator.
 - (9) Ratchet control – a device to ensure the full crimping cycle of a crimping tool.
 - (10) Turret head – a device that is attached to a crimping tool which contains more than one locator and allows the locators to be rotated to hold a contact in the correct position for crimping. It is usually interchangeable with other turret heads.
- c. Soldering related terminology:
- (1) Alloy region – the area within the solder connection where the mixing of metals occurs during the soldering process.
 - (2) Birdcaging – separation of individual strands.
 - (3) Cold solder connection – unsatisfactory connection resulting from insufficient heat and exhibiting an abrupt rise of the solder from the surface being soldered (see also disturbed solder connection, which is often referred to as a “cold joint”).

FIGURE 5A12. Glossary of terms – Continued.

MIL-STD-2003-5B(SH)
APPENDIX 5A

Glossary of terms used in this procedure (continued):

- (4) Disturbed solder joint – an unsatisfactory connection resulting from relative motion between lead/wire and the terminal area during solidification of the solder.
- (5) Excessive solder – a condition resulting in an unsatisfactory connection because the contour of the elements of the connection is completely obscured or the solder has overflowed beyond the confines of the connection area.
- (6) Fillet – solder that fills the space between conductors in an electrical connection.
- (7) Flux – a chemically active compound that is capable of promoting the wetting of metals with solder.
 - (a) Flux has a lower melting point than solder. As heat is applied to a solder joint, the flux dissolves, cleans the oxide, and aids in proper solder flow. Subsequently, the melting solder displaces the flux on the cleaned surface. At this point, the flux rises to the top and is pushed to the outer edges carrying the oxides that have been removed. At the end of this process, the surface is considered “wetted.”
 - (b) Rosin flux – a non-corrosive, nonconductive, chemically active compound capable of promoting the wetting of metals with solder by a chemical cleaning action.
- (8) Oxidation – oxygen mixing with the surface metal, forming a coating that is resistant to soldering.
- (9) Pre-tinned – solder applied to either or both the contact and conductor prior to soldering.
- (10) Solder – a metallic alloy, usually of lead and tin, used to mechanically and electrically join metallic surfaces by solidification following the wetting action of the melted alloy.
- (11) Soldered connection – an electrical connection that employs solder for bonding two or more metals with an alloy (solder).
- (12) Soldering – a process in which metallic surfaces in close physical proximity are joined by the wetting and subsequent coalescence of liquid solder, which has a much lower melting point (generally below 399.2 °F [204 °C]) than any of the metals being joined.
 - (a) Soldering is accomplished by heating the two metals and the solder to the solder’s melting point. At this time, the metal and the liquid (molten) solder merge at their interfaces and mutually diffuse into each other.
- (13) Solder heat bridge – heat transfer in soldering can be improved by placing a small amount of solder between the heat source and the connection. This is called a solder heat bridge. A solder heat bridge does just what it says – it provides a bridge through which heat can transfer.
- (14) Solder projection – an undesirable protrusion from a solidified solder joint or coating.
- (15) Tinning – the coating of a surface with a uniform layer of solder.
- (16) Wet soldering iron tip – heated soldering iron tip covered with a small quantity of molten solder to accelerate transfer of heat connection.
- (17) Wetting – the process of reducing surface resistance and tension so a liquid can spread evenly over the surface.
- (18) Wicking – the capillary action of a liquid between strands or fibers. In soldering, wicking occurs between wires or strands of wire that make up a conductor. When hot solder comes into contact with heated stranded wire, the solder wicks up the conductor between strands of wire by capillary action until it reaches wire that is not hot enough to support the wetting. The wicking effect is very useful in the application of solder to a connection point. Wicking, via capillary action, distributes solder to all areas of the conductors being joined. The harmful effects of wicking occur when solder is allowed to wick too far up a conductor, causing the conductor to become inflexible or damage the insulation.

FIGURE 5A12. Glossary of terms – Continued.

MIL-STD-2003-5B(SH)
APPENDIX 5A

Tooling and materials list:

1. The following tools are utilized in the assembly of typical connectors:
 - a. Solvent brush is used for cleaning dirt and other foreign material from connector and backshell parts.
 - b. Artist's brush is used for applying petroleum jelly and other lubricants to connector and backshell parts.
 - c. Precision mechanical stripper is used to remove insulation from conductors using blades. It consists of an adjustable stop to control the length of insulation removed.
 - d. Soldering iron is used to heat conductors and solder to provide a secure electrical connection.
 - e. Heat gun is used to heat shrink solder sleeves and shrinkable tubing.
 - f. Diagonal cutter is used to cut conductors to length, cut off a rejected crimped contact, and trim stripped conductor wires to length.
 - g. Cable shears are used to cut multi-conductor cable squarely.
 - h. Adjustable cutter is used to cut cable jackets and insulation because it is totally adjustable to prevent penetration to the underlying jacket conductors/braided shield and has a breakaway renewable blade.
 - i. Soft instrument (spudger) is a pointed instrument used to comb out the shield prior to pigtailling. It is also used to find and route conductors during connector insertion.
 - j. Tailor shears are used to cut Mylar[®], or equal (see 4.2), tape and lacing tape.
 - k. Needle nose pliers are used to peel off the scored cable jacket.
 - l. Crows foot wrench is used to tighten the adapter onto the connector.
 - m. Strap wrench is used to tighten various backshell components (i.e., sleeve to adapter and cable clamp to sleeve).
 - n. Tweezers are an alternative to fingers in tight rework situations.
 - o. Cable stripper is used to remove armor, if present, from cables because it is adjustable to prevent penetration to the underlying cable jacket.
 - p. Crimping tool is used to fasten wire conductors into crimp contacts.
 - q. Positioner is used to position the contact in the crimping tool indentors close to the proper depth.
 - r. Crimping tool gauge provides a "GO"/"NO GO" test to make sure the crimp tool indenter is close to the proper depth.
 - s. Pin contact gauge is used to test socket contact tension.
 - t. Pin vise is used to hold the pin contact gauge.
 - u. Dummy receptacle holds and transfers guide pins used for insertion of socket contacts and provides a holding base for the connector during insertion of contacts.
 - v. Guide pins provide a definite, unobstructed path for contacts to follow, prevent foreign material from accumulating inside the socket contact, and prevent misalignment caused by bunching of the connector insert.
 - w. Connector assembly fixture holds the cable and connector relative to each other and prevents movement of the conductors after they have been inserted. Any assembly fixture that provides the attributes listed in the assembly portions of this procedure will be adequate.
 - x. Insertion tool is used to install contacts into the connector contact holes.
 - y. Extraction tool is used to remove contacts from the connector.
 - z. Lockwire pliers are used to twist and cut the lockwire.
2. The following materials are utilized in connector assembly procedures:
 - a. Petroleum jelly is used to lubricate connector and backshell components.
 - b. Shrink tubing conforms to SAE-AS23053 and is used to insulate shield pigtaills, identify twisted pairs or triads, and provide environmental protection.
 - c. Lacing tape is used to form a strain relief for the shield return wire.
 - d. Transition sleeve (boot) is used at the juncture when bifurcating two cables.

FIGURE 5A13. Tooling and materials list.

MIL-STD-2003-5B(SH)
APPENDIX 5A

Tooling and materials list (continued):

- e. Solder sleeve consists of a heat shrinkable sleeve containing a preform of fluxed solder at the center and a thermoplastic sealing ring at each end.
- f. Transparent sleeving is used to provide environmental protection to exposed conductors and conforms to SAE-AS23053/5, class 1.
- g. Solvents are used to remove grease, oil, dirt, flux, and other debris from the connector, backshell components, and cable jacket.
- h. Lockwire conforming to NASM20995 NC20 is used on connectors to prevent threaded parts from backing off.

FIGURE 5A13. Tooling and materials list – Continued.

MIL-STD-2003-5B(SH)
APPENDIX 5A

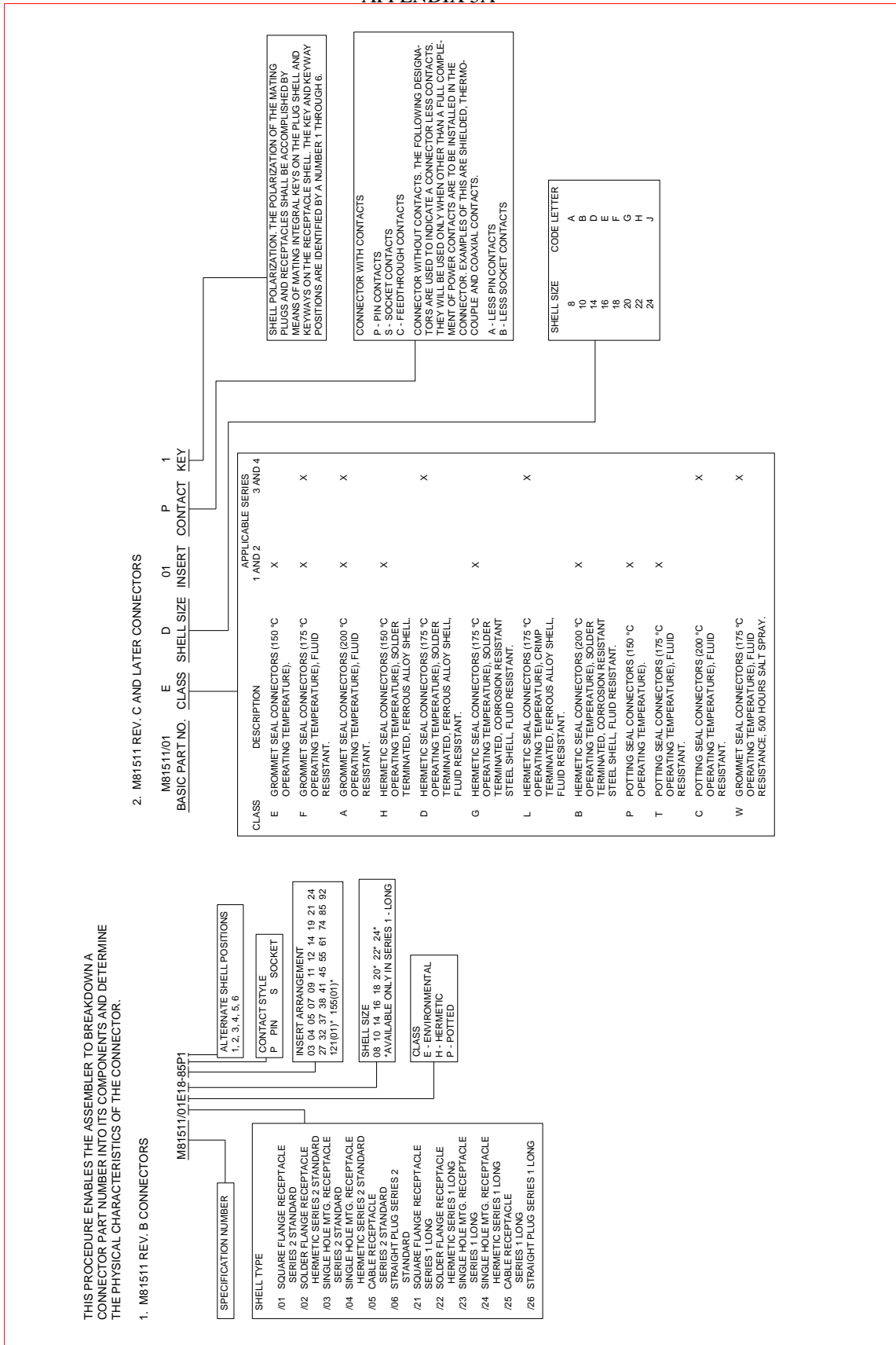

FIGURE 5A14. Connector part number nomenclature.

MIL-STD-2003-5B(SH)
APPENDIX 5A

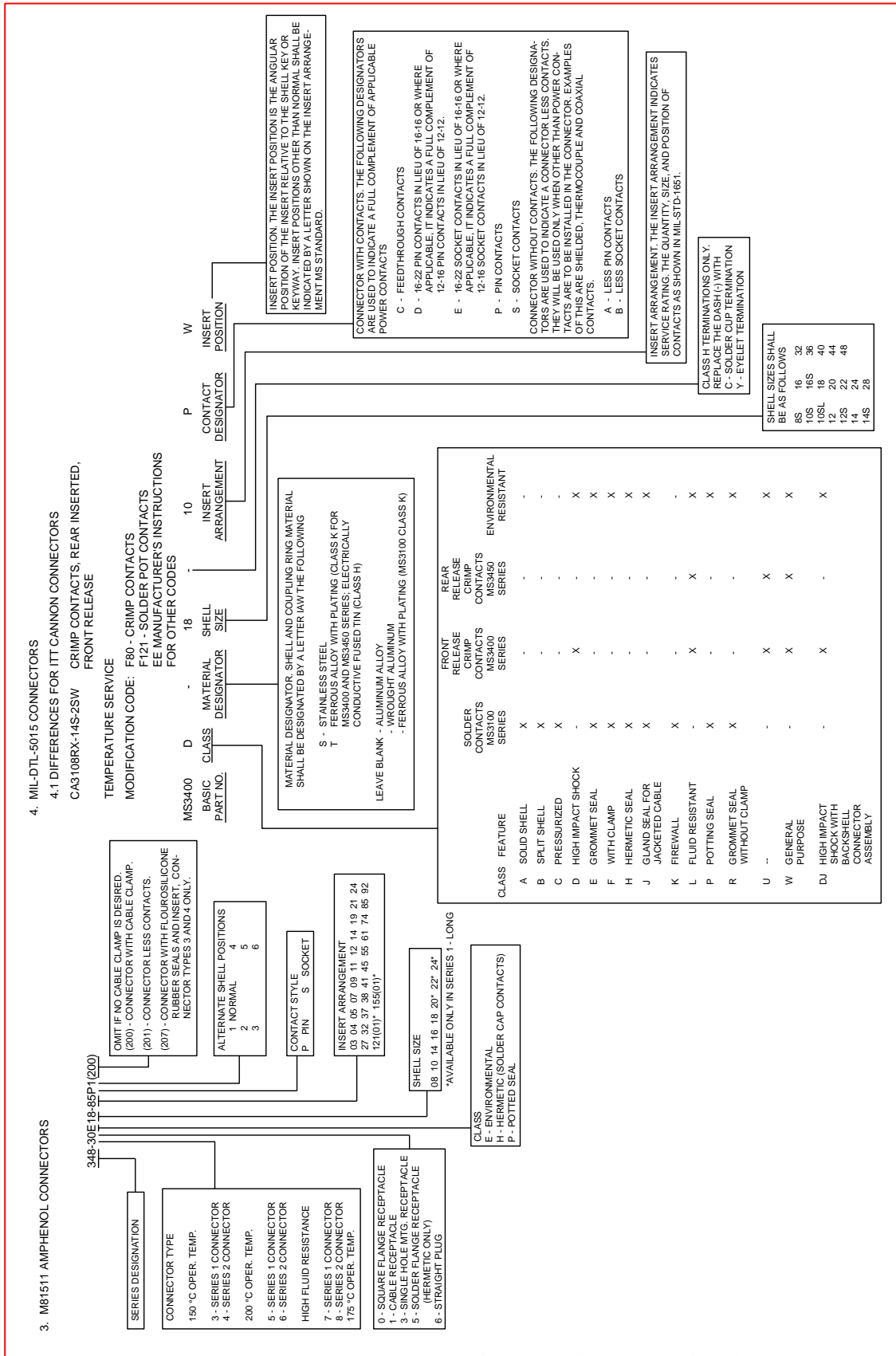
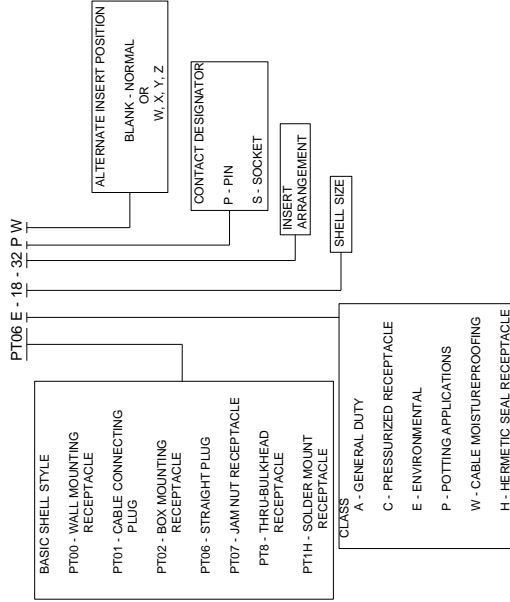

FIGURE 5A14. Connector part number nomenclature – Continued.

MIL-STD-2003-5B(SH)
APPENDIX 5A

5.1 BENDIX 'PT' CONNECTORS



4.2 BENDIX 10-214 SERIES CONNECTOR

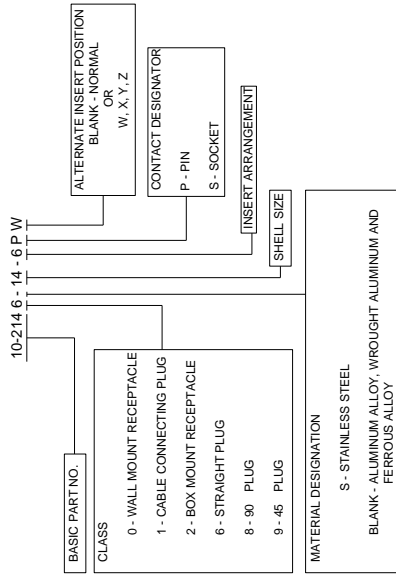

5. MIL-DTL-26482 CONNECTORS

MS STANDARD NO. MS3116 F - 20 - 16 P W

CLASS	CONNECTOR CLASS AND SERIES		FRONT RELEASE CRIMP REMOVABLE CONTACTS	REAR RELEASE CRIMP REMOVABLE CONTACTS
	SERIES 1 (125 O) SOLDER	SERIES 2 (200 O) SOLDER		
A - GROMMET SEAL, NONCONDUCTIVE				X
E - GROMMET SEAL, CONDUCTIVE	X		X	
P - POTTED SEAL, HERMETIC SEAL, CONDUCTIVE	X		X	
H - HERMETIC SEAL, CONDUCTIVE	X		X	
J - INSERT SEAL WITH GLAND SEAL FOR JACKETED CABLE	X			
L/R - FLUID RESISTANT, CONDUCTIVE				X
N - HERMETIC SEAL, NONCONDUCTIVE				X
F - GROMMET SEAL WITH STRAIN RELIEF CLAMP	X		X	

CLASS L IS UPGRADED TO 200. C AND REPLACES CLASS E.
 SERIES 2, REAR RELEASE, CRIMP REMOVABLE CONTACTS.
 CLASS R IS INACTIVE FOR NEW DESIGN.

INSERT POSITION, THE INSERT POSITION IS THE ANGULAR POSITION OF THE INSERT RELATIVE TO THE MASTER KEY OR KEYWAY OF THE SHELL. INSERT POSITIONS OTHER THAN NORMAL SHALL BE INDICATED BY THE LETTER SHOWN ON THE INSERT ARRANGEMENTS SPECIFIED BY MIL-STD-1669.

CONTACT STYLE, THE FOLLOWING DESIGNATORS ARE USED TO INDICATE A FULL COMPLIMENT OF APPLICABLE CONTACTS:
 P - PIN CONTACTS
 S - SOCKET CONTACTS
 C - FEEDTHROUGH CONTACTS

INSERT ARRANGEMENT, THE INSERT ARRANGEMENT SHOWING QUANTITY, SIZE, SERVICE RATING, AND POSITIONAL LOCATION OF CONTACTS SHALL BE AS SPECIFIED IN MIL-STD-1669.

SHELL SIZE, SHELL SIZES SHALL BE AS SPECIFIED ON THE APPLICABLE MS STANDARD.

TERMINATION TYPE AND SHELL MATERIAL (HERMETIC RECEPTACLES ONLY) FOR REAR TERMINATION AND SHELL MATERIAL SHALL BE DESIGNATED AS FOLLOWS:
 TYPE A - SOLDER CUP TERMINATION - STAINLESS STEEL SHELL (SERIES 1).
 TYPE B - EYELET TERMINATION - STAINLESS STEEL SHELL (SERIES 1).
 TYPE C - SOLDER CUP TERMINATION - FERROUS ALLOY SHELL (SERIES 1 AND 2).
 TYPE D - CRIMP TERMINATION - FERROUS ALLOY SHELL (SERIES 2).
 TYPE Y - EYELET TERMINATION - FERROUS ALLOY SHELL (SERIES 2).

FIGURE 5A14. Connector part number nomenclature – Continued.

MIL-STD-2003-5B(SH)
APPENDIX 5A

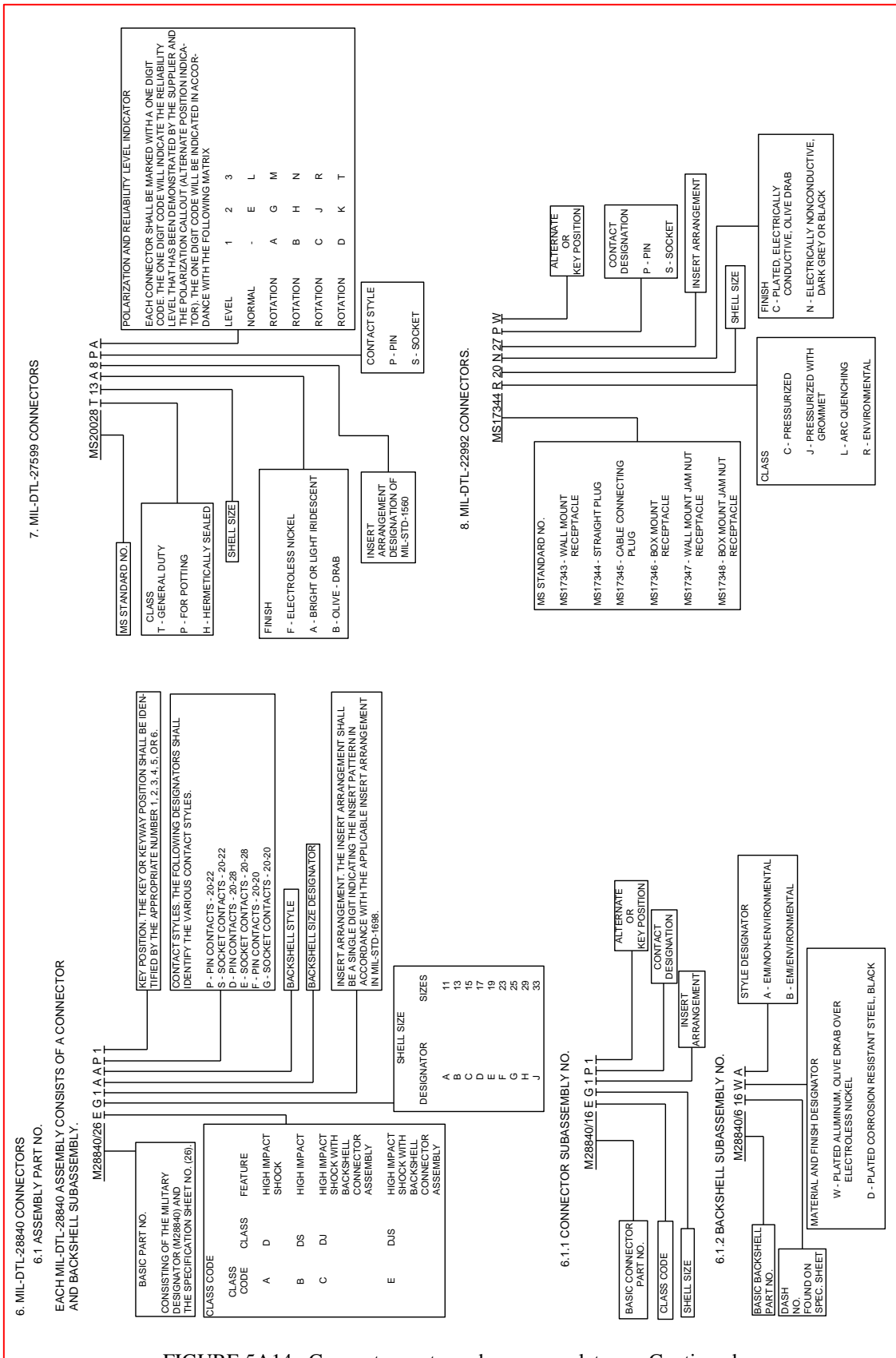
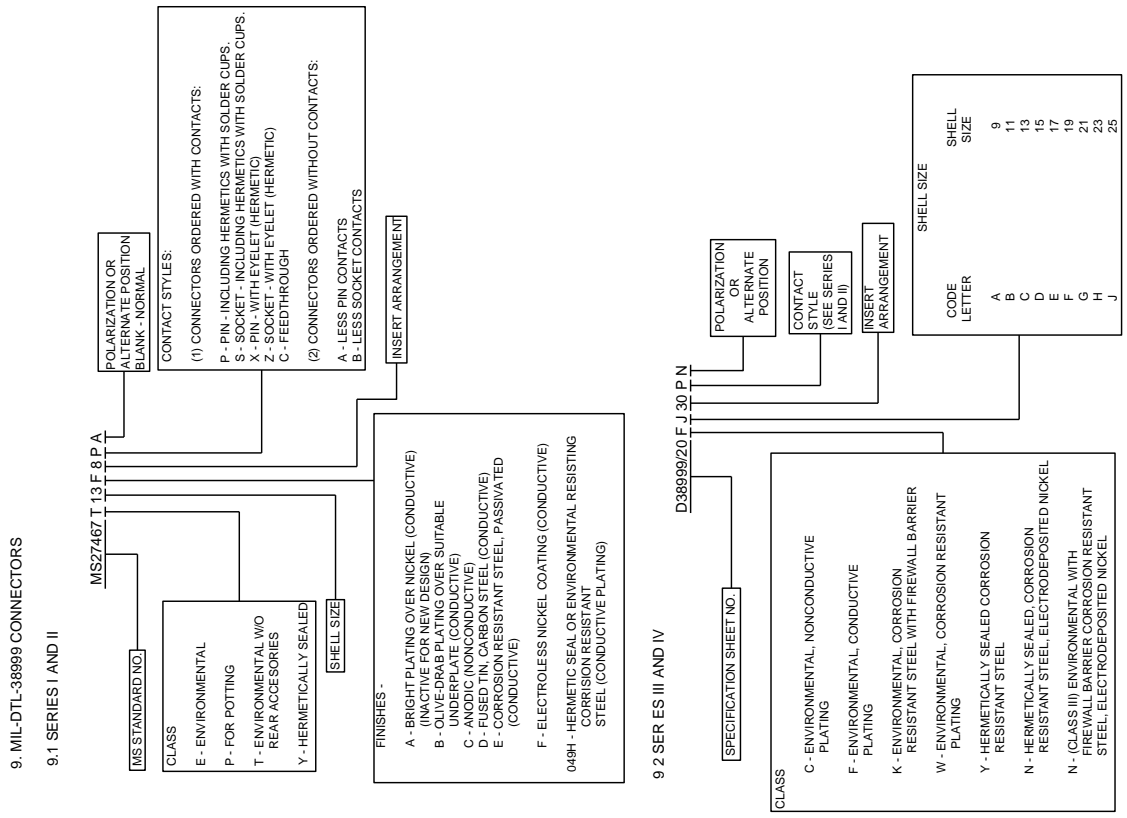

FIGURE 5A14. Connector part number nomenclature - Continued.

MIL-STD-2003-5B(SH)
APPENDIX 5A



NOTES:

1. This figure is for information to identify different characteristics of some of the electrical connectors covered by this standard. The reference standards for the connector types should be consulted for a full set of characteristics and individual connector requirements.
2. Some of the documents referenced in this figure are designated as either inactive for new design (see 4.6) or canceled. For the canceled documents, the standard is being referenced herein to cover connectors that may still be available in the various parts stock systems; however, new connectors shall not be procured to the canceled documents or to corresponding associated MS specification sheets.

FIGURE 5A14. Connector part number nomenclature – Continued.

MIL-STD-2003-5B(SH)
APPENDIX 5A

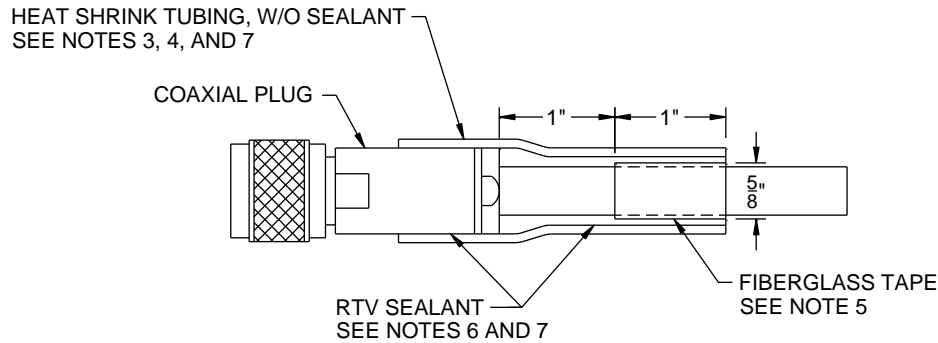

NOTES:

1. This method uses heat shrinkable tubing to waterproof a coaxial cable-plug assembly. This figure is intended to present a procedure that may be used to weather protect coaxial connectors. Other procedures may also be used, such as procedures in accordance with connector manufacturer's recommendations or the applicable ship specification.
2. Caution: Use minimum heat when shrinking tubing and avoid directing heat to cable.
3. Heat shrinkable tubing shall be polyolefin in accordance with SAE-AS23053/5, class 1. There shall be no factory applied sealant.
4. Heat shrinkable tubing dimension shall be selected such that the applied and shrunk material will fit snugly, but will be as near as practical to its fully recovered dimension.
5. Before installing the heat shrinkable tubing, clean all surfaces, then apply a layer of silicone rubber adhesive/sealant in accordance with MIL-A-46146, group II, type 1 to the cable. After the sealant becomes tacky, wrap a layer of 1-inch wide pressure sensitive silicone rubber glass tape in accordance with A-A-59770 over the sealant until a minimum diameter of $\frac{5}{8}$ inch is achieved. The space between the silicone rubber glass tape and the coaxial plug should be about 1 inch. Apply sealant in accordance with MIL-A-46146 between the coaxial connection and the tape wrap to fill the void.
6. Before shrinking, the MIL-A-46146, group II, type 1 silicone rubber adhesive/sealant shall be applied to the inside surface of the tubing at each end.
7. The heat shrinkable tubing shall be shrunk progressively from the plug end to minimize air entrapment.

FIGURE 5A15. Water-proofing coaxial connectors.

MIL-STD-2003-5B(SH)
APPENDIX 5B

APPENDIX 5B – MIL-C-81511/SAE-AS81511 SERIES 1 AND 2 GANG CONTACT RELEASE CONNECTOR
ASSEMBLY PROCEDURE

B.1 SCOPE

B.1.1 Scope. This appendix describes procedures for the preparation of MIL-C-81511/SAE-AS81511 Series 1 and 2 gang connector assembly. Note that MIL-C-81511 and most of its supporting specification sheets have been canceled and replaced by SAE-AS81511 and supporting SAE AS specification sheets. MIL-C-81511 is being referenced herein to cover MIL-C-81511 connectors that may still be available in the various parts stock systems; however, new connectors should not be procured to MIL-C-81511 or its associated specification sheets. Both specification types are being referenced to cover MIL-C-81511 connectors still in the system prior to cancellation. This appendix is a mandatory part of the standard. The information contained herein is intended for compliance.

B.2 APPLICABLE DOCUMENTS

B.2.1 General. The documents listed in this section are specified in this appendix. This section does not include documents cited in other sections of this standard or recommended for additional information or as examples. While every effort has been made to ensure the completeness of this list, document users are cautioned that they must meet all specified requirements of documents cited in this appendix, whether or not they are listed.

B.2.2 Government documents.

B.2.2.1 Other Government documents, drawings, and publications. The following other Government documents, drawings, and publications form a part of this document to the extent specified herein. Unless otherwise specified, the issues of these documents are those cited in the solicitation or contract.

MILITARY SPECIFICATION SHEETS

MS27488 - Plug, End Seal, Electrical Connector

(Copies of this document are available online at <https://quicksearch.dla.mil>.)

B.2.3 Non-Government publications. The following documents form a part of this document to the extent specified herein. Unless otherwise specified, the issues of these documents are those cited in the solicitation or contract.

SAE INTERNATIONAL

SAE-AS39029/16	-	Contacts, Electrical Connector, Socket, Crimp Removable (for AS81511 Series 4 Connectors)
SAE-AS39029/17	-	Contacts, Electrical Connector Socket, Crimp Removable (for AS81511 Series 3 Connectors)
SAE-AS39029/18	-	Contacts, Electrical Connector, Pin Crimp Removable (for AS81511 Series 3 and 4 Connectors)
SAE-AS39029/33	-	Contacts, Electrical Connector, Socket, Crimp Removable (for AS81511 Series 1 Connectors)
SAE-AS39029/46	-	Contacts, Electrical Connector, Socket, Crimp Removable (for MIL-C-81511 Series 2 Connectors)
SAE-AS39029/47	-	Contacts, Electrical Connector, Pin Crimp Removable (for AS81511 Series 1 & 2 Connectors)
SAE-AS81511	-	Connectors, Electrical, Circular, High Density, Quick Disconnect, Environment Resisting and Accessories, General Specification for

MIL-STD-2003-5B(SH)
APPENDIX 5B

- SAE-AS81511/5 - Connector, Receptacle, Cable Connecting Electrical, Circular, High Density, Quick Disconnect Environment Resisting, Crimp Type Contacts; and Accessories (Class A, F, and E - Series 2)
- SAE-AS81511/6 - Connector, Plug, Electrical, Circular, High Density, Quick Disconnect, Environment Resisting, Crimp Type Contacts; and Accessories (Class A, F, and E - Series 2)
- SAE-AS81511/15 - Accessory, Sealing Contact, Plug, Connector, Electrical, Circular, High Density, Quick Disconnect, Environment Resisting (Series 1 or 2)
- SAE-AS81511/25 - Connector, Receptacle, Cable Connecting, Electrical, Circular, High Density, Quick Disconnect, Environment Resisting, Crimp Type Contacts (Class A, F, and E - Series 1)
- SAE-AS81511/26 - Connector, Plug, Electrical, Circular, High Density, Quick Disconnect, Environment Resisting, Crimp Type Contacts (Class A, F and E - Series 1)
- SAE-AS81511/45 - Connector, Receptacle, Cable Connecting, Electrical, Circular, High Density, Quick Disconnect, Environment Resisting, Individual Release, Crimp Type Contacts (Class A, F, and W - Series 3)
- SAE-AS81511/46 - Connector, Plug, Electrical, Circular, High Density, Quick Disconnect, Environment Resisting, Individual Release, Crimp Type Contacts (Class A, F, and W - Series 3)
- SAE-AS81511/55 - Connector, Receptacle, Cable Connecting, Electrical, Circular, High Density, Quick Disconnect, Environment Resisting, Individual Release, Crimp Type Contacts (Class A, F, and W - Series 4)
- SAE-AS81511/56 - Connector, Plug, Electrical, Circular, High Density, Quick Disconnect, Environment Resisting, Individual Release, Crimp Type Contacts (Class A, F, and W - Series 4)
- SAE-AS85049 - Connector Accessories, Electrical General Specification for

(Copies of these documents are available online at www.sae.org.)

B.2.4 Order of precedence. Unless otherwise noted herein or in the contract, in the event of a conflict between the text of this document and the references cited herein, the text of this document takes precedence. Nothing in this document, however, supersedes applicable laws and regulations unless a specific exemption has been obtained.

B.3 REQUIRED EQUIPMENT AND MATERIALS

B.3.1 Required equipment and materials. The required equipment and materials are specified in the standard methods of this section.

B.4 NOTES AND PROCEDURES

B.4.1 Dimensions. For figures and tables in this appendix, all dimensions are in inches unless otherwise noted.

B.4.2 Figures. [Table 5BI](#) provides information for the figures in this appendix.

MIL-STD-2003-5B(SH)
APPENDIX 5B

TABLE 5BI. Figures for MIL-C-81511 or SAE-AS81511 connector assembly preparation.

Figure number	Connector assembly procedures	Page
5B1	MIL-C-81511 or SAE-AS81511 series 1 and 2 gang contact release connector assembly procedure	95
5B2	MIL-C-81511 or SAE-AS81511 series 3 and 4 individual contact release connector assembly procedure	107

MIL-STD-2003-5B(SH)
APPENDIX 5B

Series 1 and 2 gang contact release connector assembly procedure:

Applicable connectors: (MIL-C-81511 and associated specification sheets are cancelled and superseded by SAE-AS81511 and associated specification sheets [see B.1.1]). The procedures in this appendix specifically cover assembly of connectors in accordance with the following specification sheets and subordinate specifications of MIL-C-81511 and SAE-AS81511. This appendix may also be used to assemble connectors in accordance with other specification sheets and subordinate specifications of MIL-C-81511 and SAE-AS81511. Installation of other connectors covered in specifications subordinate to the main specification in this appendix shall use the installation requirements in this appendix to the maximum extent practicable.

MIL-C-81511/5 or SAE-AS81511/5

MIL-C-81511/6 or SAE-AS81511/6

MIL-C-81511/25 or SAE-AS81511/25

MIL-C-81511/26 or SAE-AS81511/26

1. Visual inspection and verification:

- a. Disassemble the connector/backshell assembly.
- b. Verify that the connector is of the correct type and configuration for the cable being terminated in accordance with the system cabling diagram.
- c. Verify that the backshell configuration is of the correct type as specified on the system cabling diagram.
- d. Verify that all components, parts of the connector, and backshell hardware are present (see illustration 1 for a typical connector/backshell configuration). Reference: SAE-AS81511 for connector, SAE-AS85049 for backshell, or vendor data for specific configurations.

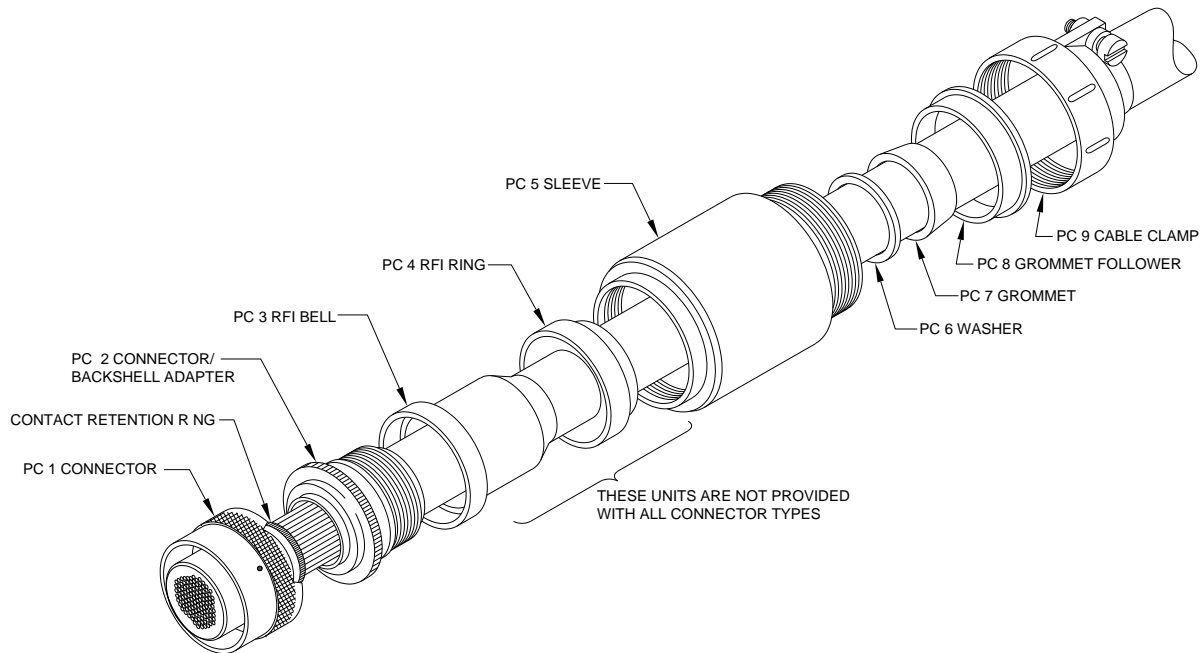

ILLUSTRATION 1
SAE-AS81511 CONNECTOR WITH COMPATIBLE BACKSHELL CONFIGURATION

FIGURE 5B1. MIL-C-81511 or SAE-AS81511 series 1 and 2 gang contact release connector assembly procedure.

MIL-STD-2003-5B(SH)
APPENDIX 5B

Series 1 and 2 gang contact release connector assembly procedure (continued):

- e. Visually inspect the components for damage such as deformed parts, gouges, damaged threads, cut O-rings, burrs, or surface damage.
 - f. Verify that contacts meet the requirements of SAE-AS39029/47 for series 1 and 2 pins, SAE-AS39029/33 for series 1 socket or SAE-AS39029/46 for series 2 socket contacts, and are the correct size and type for the connector being assembled.
 - g. If the conductors are re-twisted during lead preparation, ensure they are twisted as tight as originally constructed, the natural lay of the conductor is maintained, and the conductors will fit inside the contact barrel.
2. Prepare the cable in accordance with [figure 5A1](#).
 3. Insertion setup: Owing to the many possible variations of acceptable designs for an assembly fixture, no specification is made as to a particular type. The components for an acceptable assembly fixture are as follows: A dummy receptacle, without connector insert, to hold the connector being worked on securely; a cable-clamping fixture to hold the cable in a secure, fixed relationship to the connector while permitting access to the rear face of the connector for the contact insertion tool; a device for holding the wire bundle out of the work area; contact insertion guides for socket contacts to prevent the collapse of adjacent insert holes as the connector is gradually filled with contacts (this facet becomes increasingly important as the contact density increases).

The assembly fixture referred to in this procedure is that shown in illustration 2. NOTE: Equivalent tooling is acceptable; however, the use of other tools may affect the procedural steps outlined below.

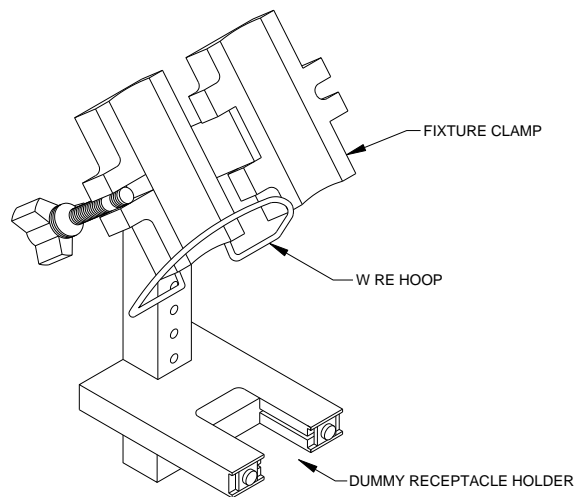
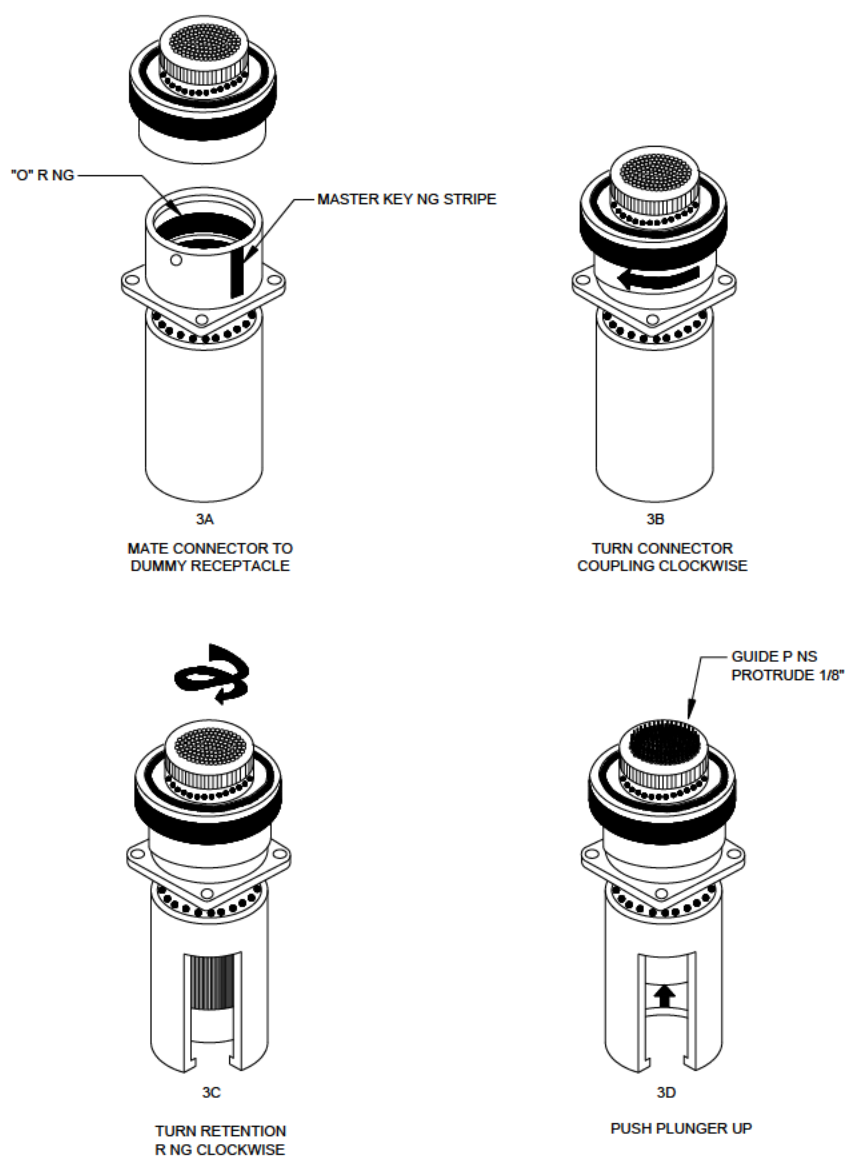

ILLUSTRATION 2
ASSEMBLY FIXTURE

- a. Secure the assembly fixture to a vise or similar holding device in order to provide a stable work area.
- b. Check the dummy receptacle (see illustration 3).
 - (1) O-ring in place and lightly lubricated with petroleum jelly (see illustration 3A).
 - (2) Retainer barrel threads lightly lubricated with petroleum jelly (for use with socket contacts only).

FIGURE 5B1. MIL-C-81511 or SAE-AS81511 series 1 and 2 gang contact release connector assembly procedure – Continued.

MIL-STD-2003-5B(SH)
APPENDIX 5BILLUSTRATION 3
DUMMY RECEPTACLE**Series 1 and 2 gang contact release connector assembly procedure (continued):**

- (3) All guide pins present and straight (for use with socket contacts only).
- (4) Guide pins pressed back into the dummy receptacle so that no more than $\frac{1}{8}$ inch projects (for use with socket contacts only).
- c. Mate the connector to the dummy receptacle/retainer barrel (if required) assembly, and lock the coupling ring (see illustration 3B).
- d. Turn the contact retention ring clockwise to the locked position (see illustration 3C).

FIGURE 5B1. MIL-C-81511 or SAE-AS81511 series 1 and 2 gang contact release connector assembly procedure – Continued.

MIL-STD-2003-5B(SH)
APPENDIX 5B**Series 1 and 2 gang contact release connector assembly procedure (continued):**

- e. Perform this step for socket contacts only. Using a wooden dowel, slowly press the guide pin plunger up in a series of short strokes. Release the upward pressure between strokes to allow the guide pins to realign themselves and relieve stress within the insert. Continue until the guide pins protrude about $\frac{1}{8}$ inch from the rear of the connector (see illustration 3D).
- f. Insert the dummy receptacle/retainer barrel (if required) assembly with attached connector into the assembly fixture. Secure the connector in the assembly fixture.
- g. Unlock the connector contact retention ring by turning counter-clockwise $2\frac{1}{2}$ turns (minimum $2\frac{1}{4}$ turns). Turn the retention ring clockwise a maximum of $\frac{1}{4}$ turn to prevent seizing.
- h. Place the prepared cable in the fixture clamp so that the first contacts to be inserted will be at the back of the connector as it is held in the dummy receptacle.
- i. Position the cable at a position similar to the backshell design (i.e., 45 degrees, 90 degrees, or straight). Secure the cable in the fixture clamp (see illustration 4A).
- j. Position the connector so that the connector to cable jacket distance is that measured in step 9.b of [figure 5A1](#). Rotate the connector to align the keyway position in proper relationship to the backshell (see illustration 4B).
- k. ~~Route the individual conductors per the applicable wiring table. Ensure that the longest routed conductor has sufficient length at the required position termination prior to cutting any conductor (see illustration 4C).~~

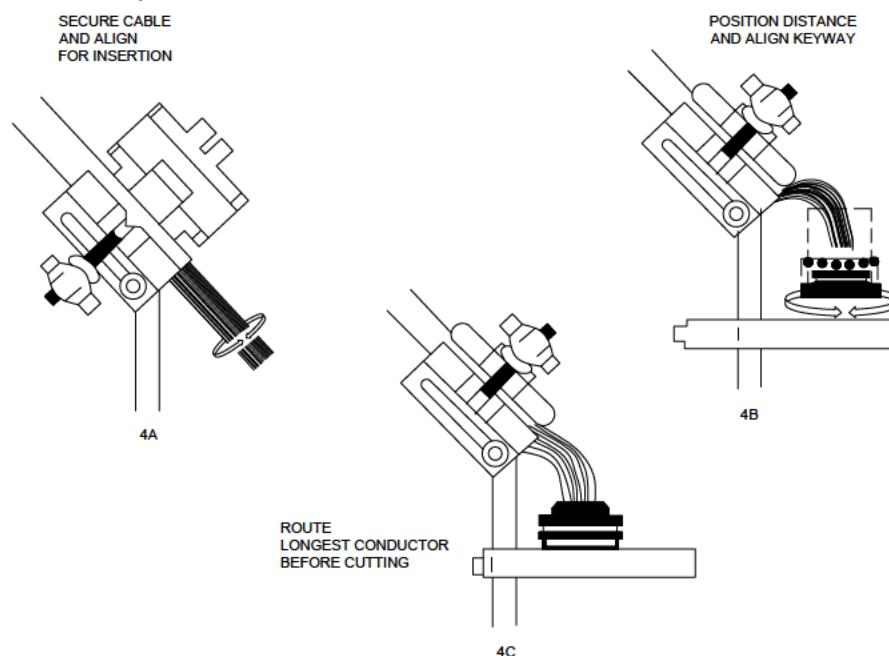
ILLUSTRATION 4
DETERMINING CONDUCTOR LENGTH

- l. Cut the conductors as required to provide even conductor lengths at the connector insert.
NOTE: Leave the spares full length.
4. Strip the individual conductors in accordance with [figure 5A3](#) (for contact wire barrel depths, see [table 5B1-I](#)).
5. Prior to crimping, verify contact sizing (see step 1 f).

FIGURE 5B1. MIL-C-81511 or SAE-AS81511 series 1 and 2 gang contact release connector assembly procedure – Continued.

MIL-STD-2003-5B(SH)
APPENDIX 5BTABLE 5B1-I. Wire barrel depths and minimum separation force.

Contact size	Wire barrel depth (inch)				Minimum separation force (oz.)
	Series 1		Series 2		Series 1 & 2
	Pin	Socket	Pin	Socket	Socket
12-12	0.276-0.296	0.276-0.296	0.276-0.296	0.276-0.296	2.5
16-16	0.266-0.286	0.266-0.286	0.266-0.286	0.266-0.286	1.5
20-20	0.256-0.276	0.256-0.276	0.256-0.276	0.256-0.276	0.6
23-22	0.215-0.235	0.215-0.235	0.215-0.235	0.215-0.235	0.4
23-28	0.215-0.235	0.215-0.235	0.215-0.235	0.215-0.235	0.4

Series 1 and 2 gang contact release connector assembly procedure (continued):

6. Terminate individual conductors with crimp contacts in accordance with [figure 5A4](#) (see [table 5B1-II](#) for proper crimping tool). If contact rework shortens a conductor's initial length by greater than ¼ inch, the jacket shall be cut back again and all conductors re-trimmed to preclude stress.

TABLE 5B1-II. Crimp tooling information.

Contact size	Series 1 & 2 pins and series 2 socket		Series 1 socket	
	Crimping tool	Positioner	Crimping tool	Positioner
12-12	M22520/1-01	M22520/1-08 Yellow	M22520/1-01	M22520/1-08 Yellow
16-16	M22520/7-01	M22520/7-10	M22520/1-01	M22520/1-08 Blue
	M22520/1-01	M22520/1-08 Blue		
20-20	M22520/7-01	M22520/7-09	M22520/1-01	M22520/1-08 Red
	M22520/1-01	M22520/1-08 Red		
23-22	M22520/2-01	M22520/2-03	M22520/2-01	M22520/2-03
23-28	M22520/2-01	M22520/2-03	M22520/2-01	M22520/2-03

- a. Secure the wire bundle in the wire hoop so that the work area at the connector face is clear.
7. Inserting contacts:
 - a. Using the proper wiring table, proper inserting tool based on contact type (see [table 5B1-III](#)), and working from the rear to the front of the insertion fixture, insert the contacts into their designated locations in the connector as follows:

FIGURE 5B1. MIL-C-81511 or SAE-AS81511 series 1 and 2 gang contact release connector assembly procedure – Continued.

MIL-STD-2003-5B(SH)
APPENDIX 5B

TABLE 5B1-III. Installation and removal tools.

Contact size	Series 1 & 2 sockets		Series 1 & 2 pins	
	Installing tool	Removal tool	Installing tool	Removal tool
12-12	MS81969/2-03	MS81969/3-08	MS81969/2-04	MS81969/3-04
16-16	MS84969/2-03	MS81969/3-07	MS81969/2-03	MS81969/3-03
20-20	MS81969/2-02	MS81969/3-06	MS81969/2-02	MS81969/3-02
23-22	MS81969/3-01	MS81969/3-05	MS81969/2-01	MS81969/3-01
23-28	MS81969/2-01	MS81969/3-05	MS81969/2-01	MS81969/3-01

Series 1 and 2 gang contact release connector assembly procedure (continued):

- (1) Push the contact straight into its designated location until the crimped portion of the contact barrel touches the rubber insert.
 - (a) For socket contacts, place the contact onto the protruding guide pin and then insert into its designated location.
 - (2) Position the insertion tool around the rear of the contact shoulder with a slight angle toward the contact, and using firm, steady pressure, push the contact straight into the connector.
 - (a) When the contact is properly seated, its shoulder will provide a positive stop.
 - (3) Remove the insertion tool by backing away from the contact and sliding straight up along the wire insulation until it clears the rubber insert.
 - (4) Upon insertion of each two rows of socket contacts, visually inspect the bottom of the dummy receptacle to ensure that the contacts are properly inserted.
 - (5) Upon insertion of each two rows of pin contacts, visually inspect the connector face to ensure that the contacts are properly inserted and do not “cross over” into adjacent holes. Any improperly inserted contacts will appear angled when compared to the properly inserted contacts.
 - (6) Adjust the fixture clamp as required during the insertion process to ease stress on the conductors.
 - (7) Ensure that the shield ground wire (if terminated to a contact) is inserted in its proper location.
 - b. Insert unwired contacts (backed up by sealing plugs, if required, conforming to MIL-C-81511/15 or SAE-AS81511/15 in all unused connector locations. Sealing plugs are required for environmental connectors, but not for non-environmental connectors.
 - c. Conduct a final visual check of the connector and verify wire location against the wiring table. Ensure no debris is inside socket contacts.
8. Seating checks (to be conducted after insertion of all contacts):
- CAUTION:** Do not force the retention ring. Failure of the retention ring to close indicates one or more unseated contacts. Use of excessive force will damage the contact retention disc.
- a. Release the fixture clamp and, grasping the cable jacket, push the entire wire bundle gently toward the connector. While continuing to exert pressure, rotate the contact retention ring to its locked position. The retention ring is fully locked when no color shows below the edge of the ring. The retention ring will not lock if one or more contacts are not fully seated. Illustration 5 illustrates the effect of an unseated contact on the retention disc. See illustrations 6 and 7 for detail of properly seated contacts.

FIGURE 5B1. MIL-C-81511 or SAE-AS81511 series 1 and 2 gang contact release connector assembly procedure – Continued.

MIL-STD-2003-5B(SH)
APPENDIX 5B

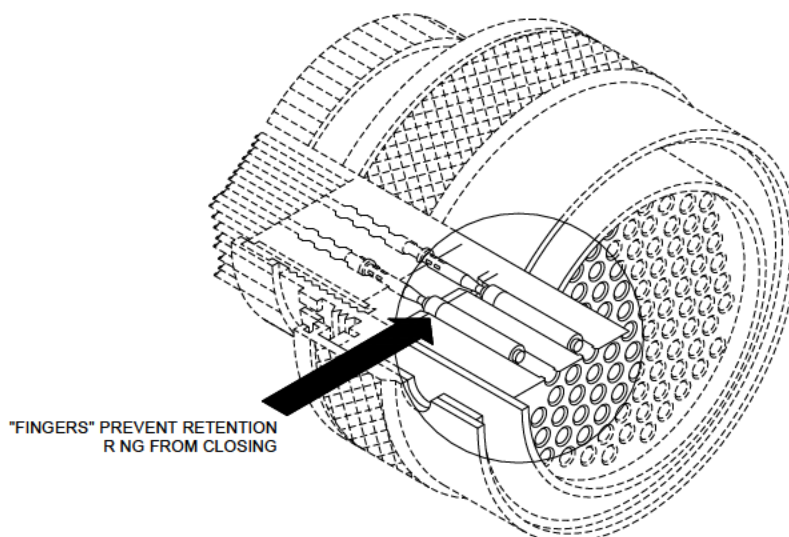

ILLUSTRATION 5
UNSEATED CONTACTS

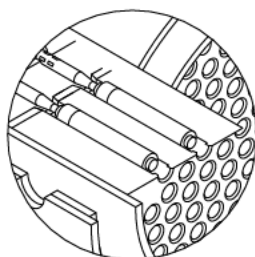

ILLUSTRATION 6
PROPERLY SEATED CONTACTS

Series 1 and 2 gang contact release connector assembly procedure (continued):

- b. Identify unseated contacts by a visual inspection of the connector face or by examination of the guide pins to detect any that are not fully pushed out by the corresponding socket contact.
- c. If required, remove unseated contacts from the connector, remove the dummy receptacle, and unlock the retention ring; insert the extraction tool into the connector face; and push the unseated contacts back through the insert until the tool bottoms out. No further extraction is necessary.
- d. Reinsert all extracted contacts, and repeat the seating checks.
- e. If the retention ring cannot be locked after three insertion attempts, replace the offending contacts. If the same contact location continues to give difficulty, the retention disc is probably damaged or faulty, and the entire connector shall be replaced.
- f. Remove the connector from the dummy receptacle upon completion of final seating checks.

FIGURE 5B1. MIL-C-81511 or SAE-AS81511 series 1 and 2 gang contact release connector assembly procedure – Continued.

MIL-STD-2003-5B(SH)
APPENDIX 5B

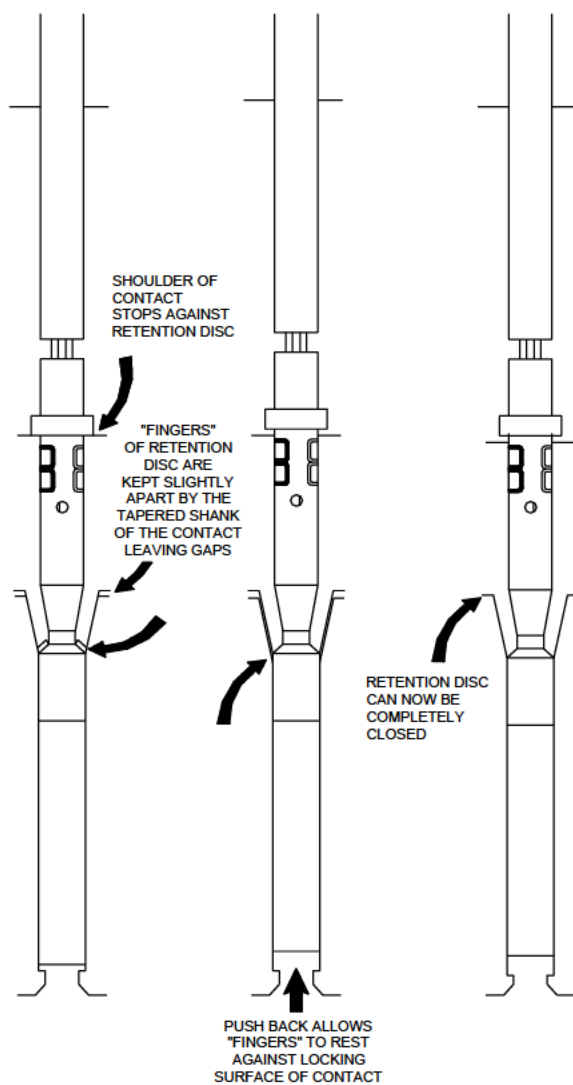

ILLUSTRATION 7
CONTACT "PUSH-BACK"

Series 1 and 2 gang contact release connector assembly procedure (continued):

9. Backshell assembly:

NOTE: The following assembly procedure is based on the nomenclature and hardware configuration depicted in illustration 1. Variations may occur and cause minor deviations from this procedure. If this situation occurs, the manufacturer's assembly instructions should be followed.

- Fold spare wires back one-half the distance between the connector and the jacket end.
- Slide a 1-inch long piece of ¼-inch shrink tubing over each folded pair and shrink in place.
- Lightly coat the threads of each backshell part with petroleum jelly just prior to using.
- Position and lubricate all O-rings.
- Remove the wire hoop and loosen the fixture clamp from the assembly fixture.
- Slide the backshell adapter down the cable and screw it onto the connector (see illustration 8). Tighten the adapter appropriately (see 4.5).

FIGURE 5B1. MIL-C-81511 or SAE-AS81511 series 1 and 2 gang contact release connector assembly procedure – Continued.

MIL-STD-2003-5B(SH)
APPENDIX 5B

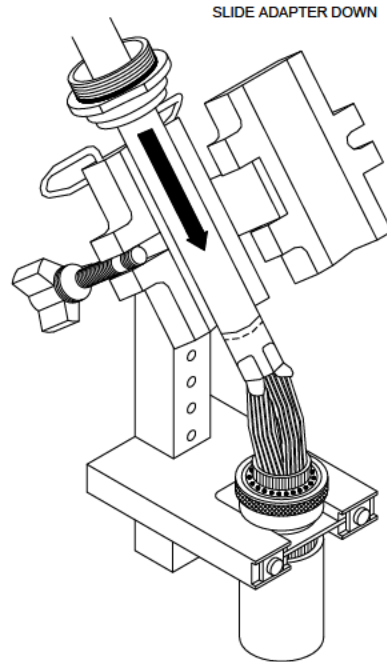

ILLUSTRATION 8
BACKSHELL ADAPTER POSITIONING

Series 1 and 2 gang contact release connector assembly procedure (continued):

- g. If the gross shield is to be floated or terminated to a connector contact, proceed to step 9 h. If the shield is to be terminated to the backshell RFI hardware, proceed as follows:
- (1) Slide the RFI bell (PC 3, illustration 1) against the backshell adapter.
 - (2) Flare the gross shield uniformly over the tapered end of the RFI bell. Shield shall not extend beyond the tapered end.
 - (3) Gently force the cable toward the connector plug until the shield covers the tapered surface on the RFI bell.
 - (4) Slide the RFI ring (PC 4, illustration 1) onto the RFI bell while applying forward pressure on the cable.
 - (5) Compress the shield between the RFI bell and RFI ring with a forward motion on the RFI ring (see illustration 9).

FIGURE 5B1. MIL-C-81511 or SAE-AS81511 series 1 and 2 gang contact release connector assembly procedure – Continued.

MIL-STD-2003-5B(SH)
APPENDIX 5B

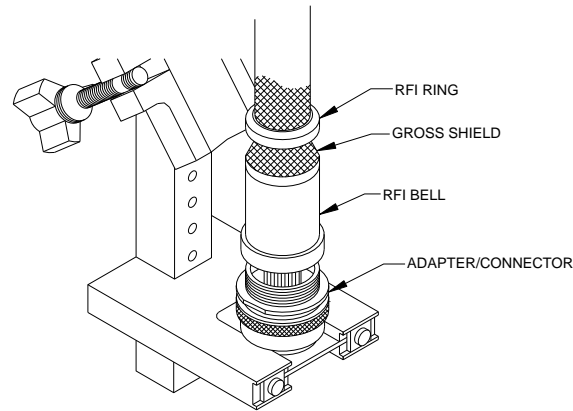

ILLUSTRATION 9
RFI COMPONENTS

Series 1 and 2 gang contact release connector assembly procedure (continued):

- h. If the gross shield is floated or terminated to a connector contact, slide the RFI backshell components (PC 3 and 4, illustration 1) over the pigtails, looped ground wire, and spare conductors.
- i. Slide the backshell sleeve (PC 5, illustration 1) over the RFI assembly and screw the sleeve onto the adapter.
- j. Tighten the sleeve appropriately (see 4.5). However, special tools are not mandatory to accomplish this procedural step.
- k. Mark a line on the cable $\frac{1}{4}$ inch to $\frac{1}{2}$ inch above the backshell sleeve (see illustration 10). Carefully push the cable into the backshell $\frac{1}{4}$ inch to $\frac{1}{2}$ inch to provide strain relief for the conductors, and maintain continuous pressure to hold at this position for the next four steps (line marked on jacket is parallel with sleeve end).

FIGURE 5B1. MIL-C-81511 or SAE-AS81511 series 1 and 2 gang contact release connector assembly procedure – Continued.

MIL-STD-2003-5B(SH)
APPENDIX 5B

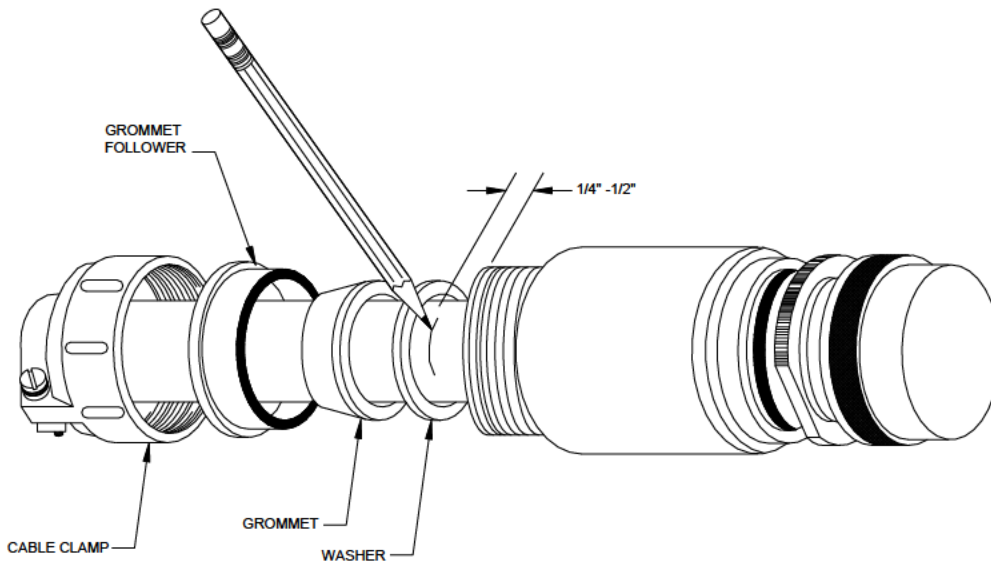

ILLUSTRATION 10
MARKING THE CABLE

Series 1 and 2 gang contact release connector assembly procedure (continued):

- l. Slide the sealing hardware washer (PC 6, illustration 1), grommet (PC 7, illustration 1), and grommet follower (PC 8, illustration 1) into position behind the sleeve.
- m. Verify the cable jacket is positioned completely through the grommet.
- n. Screw the cable clamp (PC 9, illustration 1) onto the sleeve and tighten appropriately (see 4.5). However, special tools are not mandatory to accomplish this procedural step.
- o. Alternately tighten the clamping bar screws (see illustration 11) (see 4.5).

NOTE: A minimum gap of not less than $\frac{1}{16}$ inch shall be maintained between the clamp support and clamp saddles.

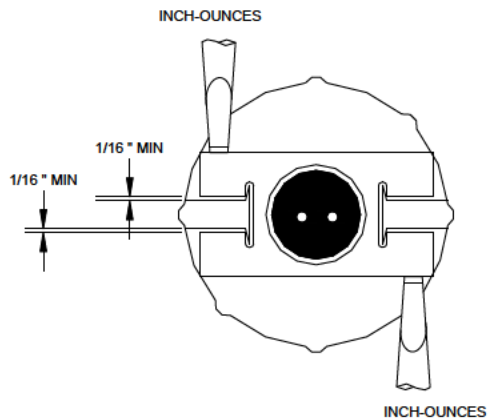

ILLUSTRATION 11
CLAMP SCREW GAP

FIGURE 5B1. MIL-C-81511 or SAE-AS81511 series 1 and 2 gang contact release connector assembly procedure – Continued.

MIL-STD-2003-5B(SH)
APPENDIX 5B

Series 1 and 2 gang contact release connector assembly procedure (continued):

- p. Remove the connector from the assembly and remove the dummy receptacle.
- 10. Final test and documentation:
 - a. Perform electrical/electronic checks on the assembled connector (see 4.5).
 - b. Install a protective dust cap on the connector.
 - c. Complete the assembly inspection and documentation as required by local procedures.
- 11. If necessary, lockwire the connector in accordance with [figure 5A9](#).

FIGURE 5B1. MIL-C-81511 or SAE-AS81511 series 1 and 2 gang contact release connector assembly procedure – Continued.

MIL-STD-2003-5B(SH)
APPENDIX 5B

Series 3 and 4 individual contact release connector assembly procedure:

Applicable connectors: (MIL-C-81511 and associated specification sheets are cancelled and superseded by SAE-AS81511 and associated specification sheets [see B.1.1]). The procedures in this appendix specifically cover assembly of connectors in accordance with the following specification sheets and subordinate specifications of MIL-C-81511 and SAE-AS81511. This appendix may also be used to assemble connectors in accordance with other specification sheets and subordinate specifications of MIL-C-81511 and SAE-AS81511. Installation of other connectors covered in specifications subordinate to the main specification in this appendix shall use the installation requirements in this appendix to the maximum extent practicable.

MIL-C-81511/45 or SAE-AS81511/45

MIL-C-81511/46 or SAE-AS81511/46

MIL-C-81511/55 or SAE-AS81511/55

MIL-C-81511/56 or SAE-AS81511/56

1. Visual inspection and verification:
 - a. Disassemble the connector/backshell assembly.
 - b. Verify that the connector is of the correct type and configuration for the cable being terminated in accordance with the system cabling diagram.
 - c. Verify that the backshell configuration is of the correct type as specified on the system cabling diagram.

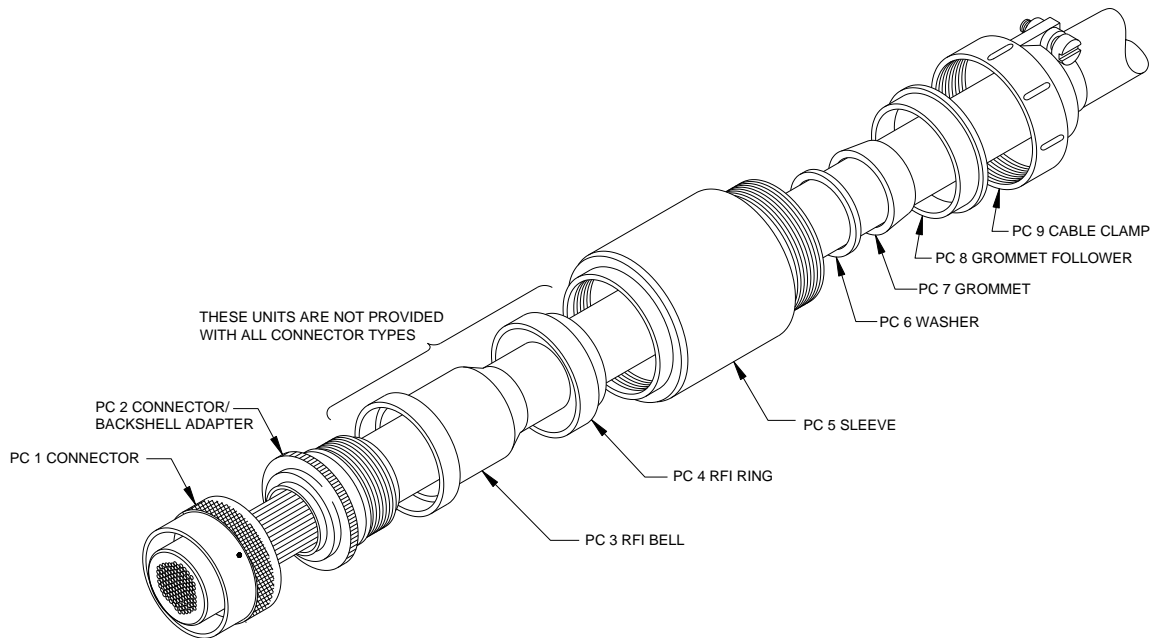

ILLUSTRATION 1
MIL-C-81511 CONNECTOR WITH COMPATIBLE BACKSHELL CONFIGURATION

FIGURE 5B2. MIL-C-81511 or SAE-AS81511 series 3 and 4 individual contact release connector assembly procedure.

MIL-STD-2003-5B(SH)
APPENDIX 5B

Series 3 and 4 individual contact release connector assembly procedure (continued):

- d. Verify that all components, parts of the connector, and backshell hardware are present (see illustration 1 for a typical connector/backshell configuration). Reference: SAE-AS81511 for connector, SAE-AS85049 for backshell or vendor data for specific configurations.
 - e. Visually inspect the components for damage such as deformed parts, gouges, damaged threads, cut O-rings, burrs, or surface damage.
 - f. Verify that contacts meet the requirements of SAE-AS39029/18 for series 3 and 4 pins, SAE-AS39029/17 for series 3 socket, and SAE-AS39029/16 for series 4 socket and are the correct size and type for the connector being assembled.
 - g. If the conductors are re-twisted during lead preparation, ensure they are twisted as tight as originally constructed, the natural lay of the conductor is maintained, and the conductors will fit inside the contact barrel.
2. Prepare the cable in accordance with [figure 5A1](#).
 3. Insertion setup: Owing to the many possible variations of acceptable designs for an assembly fixture, no specification is made as to a particular type. The components, that are desirable for an acceptable assembly fixture, are as follows: A dummy receptacle, without connector insert, to hold the connector being worked on securely; a cable-clamping fixture to hold the cable in a secure, fixed relationship to the connector while permitting access to the rear face of the connector for the contact insertion tool; a device for holding the wire bundle out of the work area.

The assembly fixture referred to in this procedure is that shown in illustration 2.

NOTE: Equivalent tooling is acceptable; however, the use of other tools may affect the procedural steps outlined below.

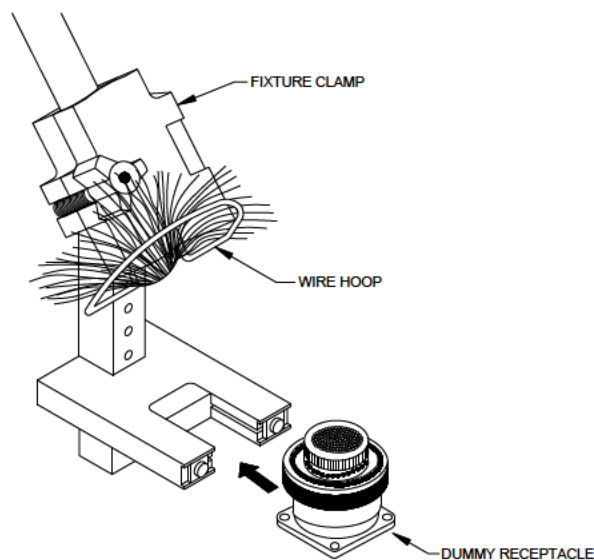

ILLUSTRATION 2
ASSEMBLY FIXTURE

- a. Secure the assembly fixture to a vise or similar holding device in order to provide a stable work area.
- b. Check the dummy receptacle (see illustration 3) (dummy receptacle without retainer barrel).
 - (1) O-ring in place and lightly lubricated with petroleum jelly (see illustration 3A).
- c. Mate the connector to the dummy receptacle and lock the coupling ring (see illustration 3B).

FIGURE 5B2. MIL-C-81511 or SAE-AS81511 series 3 and 4 individual contact release connector assembly procedure – Continued.

MIL-STD-2003-5B(SH)
APPENDIX 5B

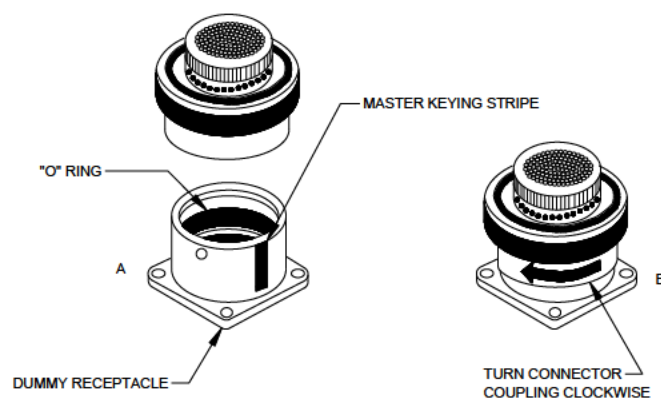
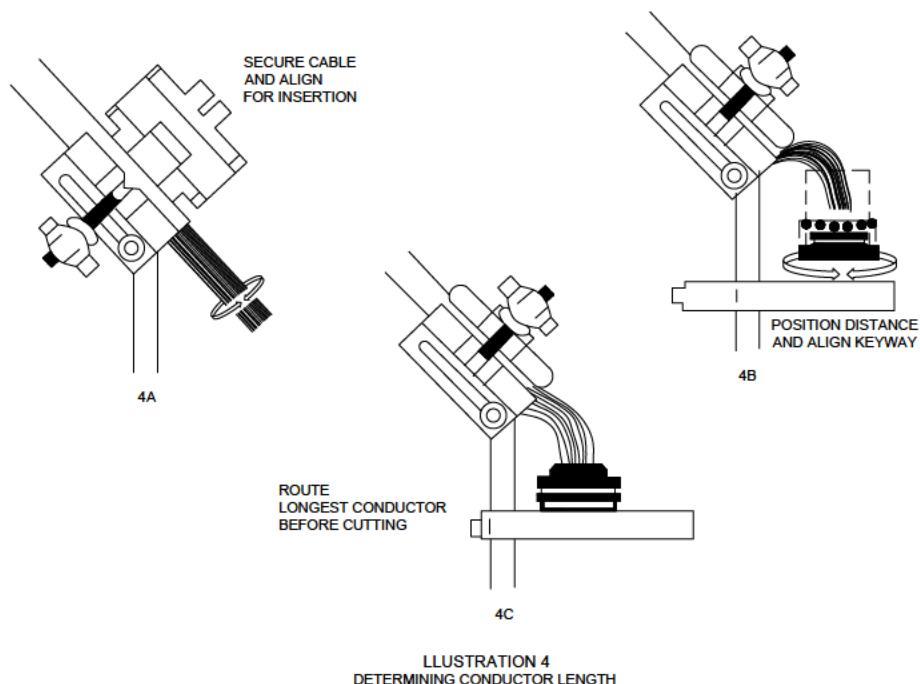

ILLUSTRATION 3
MATE CONNECTOR TO DUMMY RECEPTACLE

Series 3 and 4 individual contact release connector assembly procedure (continued):

- d. Insert the dummy receptacle with attached connector into the assembly fixture. Secure the connector in the assembly fixture.
 - e. Place the prepared cable in the fixture clamp so that the first contacts to be inserted will be at the back of the connector as it is held in the dummy receptacle.
 - f. Position the cable at a position similar to the backshell design (i.e., 45 degrees, 90 degrees, or straight). Secure the cable in the fixture clamp (see illustration 4A).
 - g. Position the connector so that the connector-to-cable jacket distance is that measured in step 9.b of [figure 5A1](#). Rotate the connector to align the keyway position in proper relationship to the backshell (see illustration 4B).
 - h. Route the individual conductors in accordance with the applicable wiring table. Ensure that the longest routed conductor has sufficient length at the required position termination prior to cutting any conductor (see illustration 4C).
 - i. Cut the conductors as required to provide even conductor lengths at the connector insert.
- NOTE: Leave the spares full length.

FIGURE 5B2. MIL-C-81511 or SAE-AS81511 series 3 and 4 individual contact release connector assembly procedure – Continued.

MIL-STD-2003-5B(SH)
APPENDIX 5B**Series 3 and 4 individual contact release connector assembly procedure (continued):**

4. Strip the individual conductors in accordance with [figure 5A3](#) (for contact wire barrel depths, see [table 5B2-I](#)).

TABLE 5B2-I. Wire barrel depths.

Contact size	Wire barrel depth (inch)			
	Series 3		Series 4	
	Pin	Socket	Pin	Socket
12-12	0.216–0.232	0.216–0.232	0.216–0.232	0.216–0.232
16-16	0.185–0.195	0.185–0.195	0.185–0.195	0.185–0.195
20-20	0.185–0.195	0.185–0.195	0.185–0.195	0.185–0.195
23-22	0.145–0.155	0.145–0.155	0.145–0.155	0.145–0.155
23-28	0.145–0.155	0.145–0.155	0.145–0.155	0.145–0.155

NOTE: For class L socket contacts, the barrel depth is 0.160 inch to 0.170 inch.

5. Prior to crimping, a contact sizing test should be accomplished (see step 1 f).
6. Terminate individual conductors with crimp contacts in accordance with [figure 5A4](#) (see [table 5B2-II](#) for proper crimping tool). If contact rework shortens a conductor's initial length by greater than $\frac{1}{4}$ inch, the jacket shall be cut back again and all conductors re-trimmed to preclude stress.
 - a. Secure the wire bundle in the wire hoop so that the work area at the connector face is clear.

FIGURE 5B2. MIL-C-81511 or SAE-AS81511 series 3 and 4 individual contact release connector assembly procedure – Continued.

MIL-STD-2003-5B(SH)
APPENDIX 5B

TABLE 5B2-II. Crimp tooling information.

Contact size	Series 3 & 4 pin class L socket	
	Crimping tool	Positioner
16-16	M22520/2-01	M22520/2-21
20-20	M22520/2-01	M22520/2-20
22-22	M22520/2-01	M22520/2-19
22-28	M22520/2-01	M22520/2-19

TABLE 5B2-II. Crimp tooling information – Continued.

Contact size	Series 3 & 4 pins and series 4 socket		Series 3 socket	
	Crimping tool	Positioner	Crimping tool	Positioner
12-12	M22520/1-01	M22520/1-09	M22520/1-01	M22520/1-10
16-16	M22520/7-01	M22520/7-03	M22520/2-01	M22520/2-18
	M22520/2-01	M22520/2-15	M22520/7-01	M22520/7-03
20-20	M22520/7-01	M22520/7-02	M22520/2-01	M22520/2-17
	M22520/2-01	M22520/2-14	M22520/7-01	M22520/7-02
23-22	M22520/2-01	M22520/2-13	M22520/2-01	M22520/2-16
23-28	M22520/2-01	M22520/2-13	M22520/2-01	M22520/2-16

Series 3 and 4 individual contact release connector assembly procedure (continued):

7. Inserting contacts:
 - a. Using the proper wiring table, proper inserting tool based on contact type (see [table 5B2-III](#)), and working from the rear to the front of the insertion fixture, insert the contacts into their designated locations in the connector as follows:

FIGURE 5B2. MIL-C-81511 or SAE-AS81511 series 3 and 4 individual contact release connector assembly procedure – Continued.

MIL-STD-2003-5B(SH)
APPENDIX 5B

TABLE 5B2-III. Installing and removal tools.

Contact size	Series 3 & 4 pin and socket		
	Installing tool	Removal tool	
		Wired contact	Unwired contact
12-12	M81969/16-03	M81969/16-03	M81969/30-04
16-16	M81969/16-02	M81969/16-02	M81969/30-03
20-20	M81969/16-01	M81969/16-01	M81969/30-02
23-22	M81969/16-04	M81969/16-04	M81969/30-01
23-28	M81969/16-04	M81969/16-04	M81969/30-01
Contact size	Series 3 & 4 class I socket contact		
	Installing tool	Removal tool	
		Wired contact	Unwired contact
16-16	M81969/16-02 blue	M81969/16-02 white	M81969/30-03 blue
20-20	M81969/16-01 red	M81969/16-01 white	M81969/30-02 red
22-22	M81969/16-04 green	M81969/16-04 white	M81969/30-01 yellow
22-28	M81969/16-04 green	M81969/16-04 white	M81969/30-01 yellow

Series 3 and 4 individual contact release connector assembly procedure (continued):

- (1) Hold the insertion tool between the thumb and forefinger and lay the wire against the slot of the tool.
- (2) Snap the wire into the slot.
- (3) Seat the retention shoulder of the contact against the tip of the tool.
- (4) Slowly push the wired contact straight into the opening at the rear of the insert.
- (5) Apply straight, steady, forward pressure on the tool until the contact bottoms.
- (6) Remove the tool by sliding it straight back along the wire.
- (7) Unsnap the tool from the wire when it is clear of the insert.
- (a) Lightly pull on inserted lead to ensure contact has locked in connector.
- (8) Adjust the fixture clamp as required during the insertion process to ease stress on the conductors.
- (9) Ensure that the shield ground wire (if terminated to a contact) is inserted in its proper location.
- (10) Upon insertion of each two rows of contacts, visually inspect the connector face to ensure that the contacts are properly inserted and do not “cross over” into adjacent holes. Any improperly inserted contacts will appear angled when compared to the properly inserted contacts.
- b. Insert unwired contacts (backed up by sealing plugs, if required, conforming to MS27488) in all unused contact locations. Sealing plugs are required for environmental connectors, but not for non-environmental connectors.
- c. Conduct a visual check of the connector, and verify wire location against the wiring table. Ensure no debris is inside socket contacts.
8. Contact removal procedure (as required):
 - a. Remove the connector from the dummy receptacle.
 - b. Using the extraction tool, remove any unseated contacts as follows:
 - (1) Lay the wire of the contact to be removed along the slot of the tool leaving ½ inch from the end of the tool to the rear of the connector.
 - (2) Squeeze the wire firmly into the tool between the thumb and forefinger about ½ inch from the tip.

FIGURE 5B2. MIL-C-81511 or SAE-AS81511 series 3 and 4 individual contact release connector assembly procedure – Continued.

MIL-STD-2003-5B(SH)
APPENDIX 5B

Series 3 and 4 individual contact release connector assembly procedure (continued):

- (3) Slide the tool down along the wire and into the rear cavity and slowly around the contact until a positive resistance is felt. Continue until the tool is bottomed, unlocking the connector contact retention fingers.
- (4) Pull both the tool and contact wire assembly out of the connector simultaneously.

NOTE: Do not rotate the tool as this may damage the insert.

c. Reinsert all extracted contacts.

9. Backshell assembly:

NOTE: The following assembly procedure is based on the nomenclature and hardware configuration depicted in illustration 1. Variations may occur and cause minor deviations from this procedure. If this situation occurs, the manufacturer's assembly instructions should be followed.

- a. Fold spare wires back one-half the distance between the connector and the jacket end.
- b. Slide a 1-inch long piece of ¼-inch shrink tubing over each folded pair and shrink in place.
- c. Lightly coat the threads of each backshell part with petroleum jelly just prior to using.
- d. Position and lubricate all O-rings.
- e. Remove the wire hoop and loosen the fixture clamp from the assembly fixture.
- f. Slide the backshell adapter down the cable and screw it onto the connector (see illustration 5). Tighten the adapter appropriately (see 4.5).

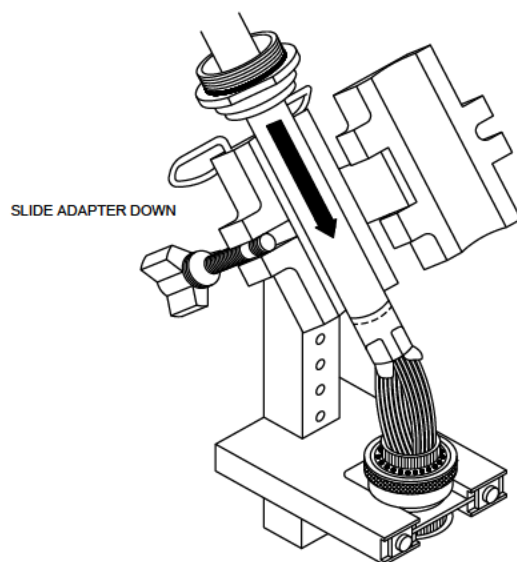

ILLUSTRATION 5
BACKSHELL ADAPTER POSITIONING

- g. If the gross shield is to be floated or terminated to a connector contact, proceed to step 9 h. If the shield is to be terminated to the backshell RFI hardware, proceed as follows:
 - (1) Slide the RFI bell (PC 3, illustration 1) against the backshell adapter.
 - (2) Flare the gross shield uniformly over the tapered end of the RFI bell. Shield shall not extend beyond the tapered end.
 - (3) Gently force the cable toward the connector plug until the shield covers the tapered surface of the RFI bell.
 - (4) Slide the RFI ring (PC 4, illustration 1) onto the RFI bell while applying forward pressure on the cable.
 - (5) Compress the shield between the RFI bell and RFI ring with a forward motion on the RFI ring (see illustration 6).

FIGURE 5B2. MIL-C-81511 or SAE-AS81511 series 3 and 4 individual contact release connector assembly procedure – Continued.

MIL-STD-2003-5B(SH)
APPENDIX 5B

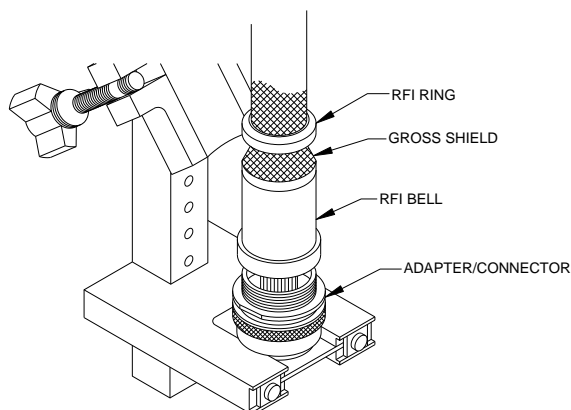
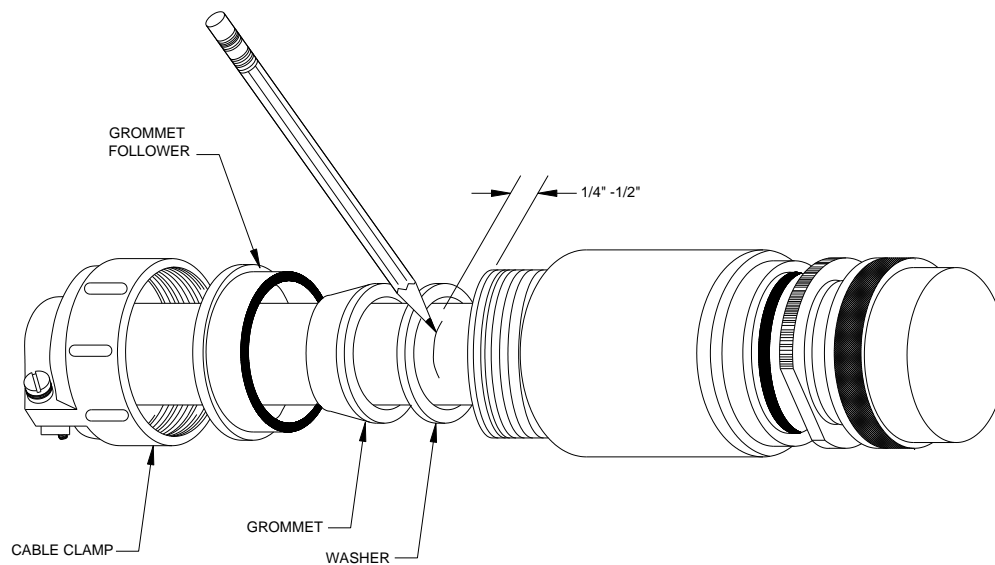

ILLUSTRATION 6
RFI COMPONENTS

Series 3 and 4 individual contact release connector assembly procedure (continued):

- h. If the gross shield is floated or terminated to a connector contact, slide the RFI backshell components (PC 3 and 4, illustration 1) over the pigtails, looped ground wire, and spare conductors.
- i. Slide the backshell sleeve (PC 5, illustration 1) over the RFI assembly and screw the sleeve onto the adapter.
- j. Tighten the sleeves appropriately (see 4.5).
- k. Mark a line on the cable $\frac{1}{4}$ inch to $\frac{1}{2}$ inch above the backshell sleeve (see illustration 7). Carefully push the cable into the backshell $\frac{1}{4}$ inch to $\frac{1}{2}$ inch to provide strain relief for the conductors and maintain continuous pressure to hold at this position for the next four steps (line marked on jacket is parallel with sleeve end).
- l. Verify the cable jacket is positioned completely through the grommet.
- m. Slide the sealing hardware washer (PC 6, illustration 1), grommet (PC 7, illustration 1), and grommet follower (PC 8, illustration 1) into position behind the sleeve.
- n. Screw the cable clamp (PC 9, illustration 1) onto the sleeve and tighten appropriately (see 4.5).
(1) Alternately tighten the clamping bar screws (see illustration 8).
- p. Remove the connector from the assembly and remove the dummy receptacle.

FIGURE 5B2. MIL-C-81511 or SAE-AS81511 series 3 and 4 individual contact release connector assembly procedure – Continued.

MIL-STD-2003-5B(SH)
APPENDIX 5BILLUSTRATION 7
MARKING THE CABLE

~~NOTE: Tighten the clamping bar screws to maintain a minimum gap of not less than $\frac{1}{16}$ inch between the clamp support and clamp saddles (see 4.5).~~

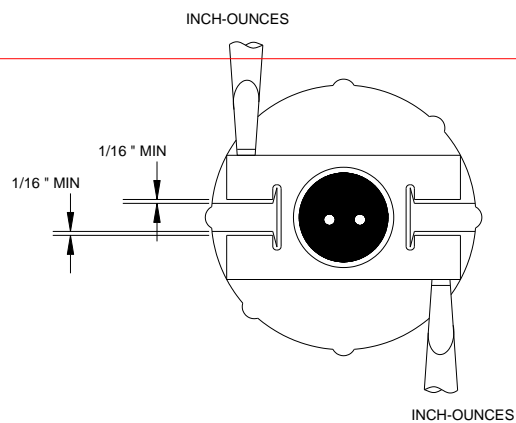
ILLUSTRATION 8
CLAMP SCREW GAP**Series 3 and 4 individual contact release connector assembly procedure (continued):**

10. Final test and documentation:
 - a. Perform electrical/electronic checks on the assembled connector (see 4.5).
 - b. Install a protective dust cap on the connector.
 - c. Complete the assembly inspection and documentation as required by local procedures.
11. If necessary, lockwire the connector in accordance with [figure 5A9](#).

FIGURE 5B2. MIL-C-81511 or SAE-AS81511 series 3 and 4 individual contact release connector assembly procedure – Continued.

MIL-STD-2003-5B(SH)
APPENDIX 5C

APPENDIX 5C – MIL-DTL-5015/SAE-AS50151 CONNECTORS

C.1 SCOPE

C.1.1 Scope. This appendix describes procedures for the preparation of MIL-DTL-5015/SAE-AS50151 connector assemblies. Note that MIL-DTL-5015 and most of its supporting MS specification sheets have been canceled and replaced by SAE-AS50151 and supporting SAE AS specification sheets. In addition, SAE-AS31071 has been canceled. MIL-DTL-5015 is being referenced herein to cover MIL-DTL-5015 connectors that may still be available in the various parts stock systems; however, new connectors should not be procured to MIL-DTL-5015 or its associated MS specification sheets or to SAE-AS31071. Both specification types are being referenced to cover MIL-DTL-5015 connectors and SAE-AS31071 connectors still in the system prior to cancellation. This appendix is a mandatory part of the standard. The information contained herein is intended for compliance.

C.2 APPLICABLE DOCUMENTS

C.2.1 General. The documents listed in this section are specified in this appendix. This section does not include documents cited in other sections of this standard or recommended for additional information or as examples. While every effort has been made to ensure the completeness of this list, document users are cautioned that they must meet all specified requirements of documents cited in this appendix, whether or not they are listed.

C.2.2 Government documents.

C.2.2.1 Specifications, standards, and handbooks. The following specifications, standards, and handbooks form a part of this document to the extent specified herein. Unless otherwise specified, the issues of these documents are those cited in the solicitation or contract.

DEPARTMENT OF DEFENSE SPECIFICATIONS

MIL-DTL-24643 - Cables, Electric, Low Smoke Halogen-Free, for Shipboard Use, General Specification for

(Copies of this document are available online at <https://quicksearch.dla.mil>.)

C.2.2.2 Other Government documents, drawings, and publications. The following other Government documents, drawings, and publications form a part of this document to the extent specified herein. Unless otherwise specified, the issues of these documents are those cited in the solicitation or contract.

MILITARY SPECIFICATION SHEETS

MS3187 - Plug, End Seal, for MIL-DTL-26482, SAE-AS50151, SAE-AS81703 and MIL-DTL-83723 Electrical Connectors

MS27488 - Plug, End Seal, Electrical Connector

(Copies of these documents are available online at <https://quicksearch.dla.mil>.)

C.2.3 Non-Government publications. The following documents form a part of this document to the extent specified herein. Unless otherwise specified, the issues of these documents are those cited in the solicitation or contract.

SAE INTERNATIONAL

SAE-AS8660 - Silicone Compound NATO Code Number S-736

SAE-AS31011 - Connector, Receptacle, Electric, Cable Connecting, Solder Contacts, AN Type

SAE-AS31051 - Connector, Receptacle, Electric, Dummy Stowage

SAE-AS31061 - Connector, Plug, Electric, Straight, Solder Contacts, AN Type

SAE-AS31081 - Connectors, Plug, Electric, Solder Contact, 90°, AN Type

MIL-STD-2003-5B(SH)
APPENDIX 5C

SAE-AS34001	- Connectors, Receptacle, Electric, Wall Mounting, Front Release, Crimp Contact, AN Type
SAE-AS34011	- Connectors, Receptacle, Electric, Cable Connecting, Front Release, Crimp Contact, AN Type
SAE-AS34061	- Connectors, Plug, Electric, Front Release, Crimp Contact, AN Type
SAE-AS34081	- Connectors, Plug, Electric, 90 Degree Assembly, Crimp Contact AN Type
SAE-AS34501	- Connectors, Receptacle, Electrical, Wall Mounting, Rear Release, Crimp Contact, AN Type
SAE-AS34511	- Connectors, Receptacle, Electric, Cable Connecting, Rear Release, Crimp Contact, AN Type
SAE-AS34561	- Connectors, Plug, Electrical, Rear Release, Crimp Contact, AN Type
SAE-AS34591	- Connector, Plug, Electrical, Self-Locking, Coupling Nut, Rear Release, Crimp Contact, AN Type
SAE-AS39029/29	- Contacts, Electrical Connector, Pin, Crimp Removable (for AS50151 Series, AS345XX and MIL-DTL-83723 Series 2 Connectors)
SAE-AS39029/30	- Contacts, Electrical Connector, Socket, Crimp Removable (for AS50151 AS345XX Series and MIL-DTL-83723 Series II Connectors)
SAE-AS39029/44	- Contacts, Electrical Connector, Pin, Crimp Removable (for AS50151 Series AS34001 and AS95234 Connectors)
SAE-AS39029/45	- Contacts, Electrical Connector, Socket, Crimp Removable (for AS50151 Series AS34001 and AS95234 Connectors)
SAE-AS50151	- Connectors, Electrical, Circular Threaded, AN Type, General Specification for
SAE-AS85049	- Connector Accessories, Electrical General Specification for

(Copies of these documents are available online at www.sae.org.)

C.2.4 Order of precedence. Unless otherwise noted herein or in the contract, in the event of a conflict between the text of this document and the references cited herein, the text of this document takes precedence. Nothing in this document, however, supersedes applicable laws and regulations unless a specific exemption has been obtained.

C.3 REQUIRED EQUIPMENT AND MATERIALS

C.3.1 Required equipment and materials. The required equipment and materials are specified in the standard methods of this section.

C.4 NOTES AND PROCEDURES

C.4.1 Dimensions. For figures and tables in this appendix, all dimensions are in inches unless otherwise noted.

C.4.2 Figures. [Table 5CI](#) provides information for the figures in this appendix.

MIL-STD-2003-5B(SH)
APPENDIX 5CTABLE 5CI. Figures for MIL-DTL-5015/SAE-AS50151 connector assembly preparation.

Figure number	MIL-DTL-5015/SAE-AS50151 connector assembly procedures	Page
5C1	MIL-DTL-5015/SAE-AS50151 solder connector assembly procedure	119
5C2	MIL-DTL-5015/SAE-AS50151 (crimp) connector assembly procedure	124
5C3	Multi-cable connector assembly using grommets	137

MIL-STD-2003-5B(SH)
APPENDIX 5C

MIL-DTL-5015/SAE-AS50151 solder connector assembly procedure:

Applicable connectors: MIL-DTL-5015 and associated MS specification sheets are cancelled and superseded by SAE-AS50151 and associated subordinate SAE specifications (see C.1.1). The procedures in this appendix specifically cover assembly of connectors in accordance with the following specification sheets and subordinate specifications of MIL-DTL-5015 and SAE-AS50151. This appendix may also be used to assemble connectors in accordance with other specification sheets and subordinate specifications of MIL-DTL-5015 and SAE-AS50151. Installation of other connectors covered in specifications subordinate to the main specification in this appendix shall use the installation requirements in this appendix to the maximum extent practicable.

MS3101/SAE-AS31011

MS3106/SAE-AS31061

MS3107/SAE-AS31071 (SAE-AS31071 is canceled without replacement [see C.1.1])

MS3108/SAE-AS31081

10-109 series

1. Visual inspection and verification:

- a. Disassemble the connector/backshell assembly.
- b. Verify that the connector is of the correct type and configuration for the cable being terminated in accordance with the system cabling diagram.
- c. Verify that the backshell configuration is of the correct type as specified on the system cabling diagram.
- d. Verify that all component parts of the connector and backshell hardware are present. (See illustration 1 for typical connector/backshell configurations.)

Reference: MIL-DTL-5015/SAE-AS50151 for connector, SAE-AS85049 for backshell, or vendor data for specific configurations.

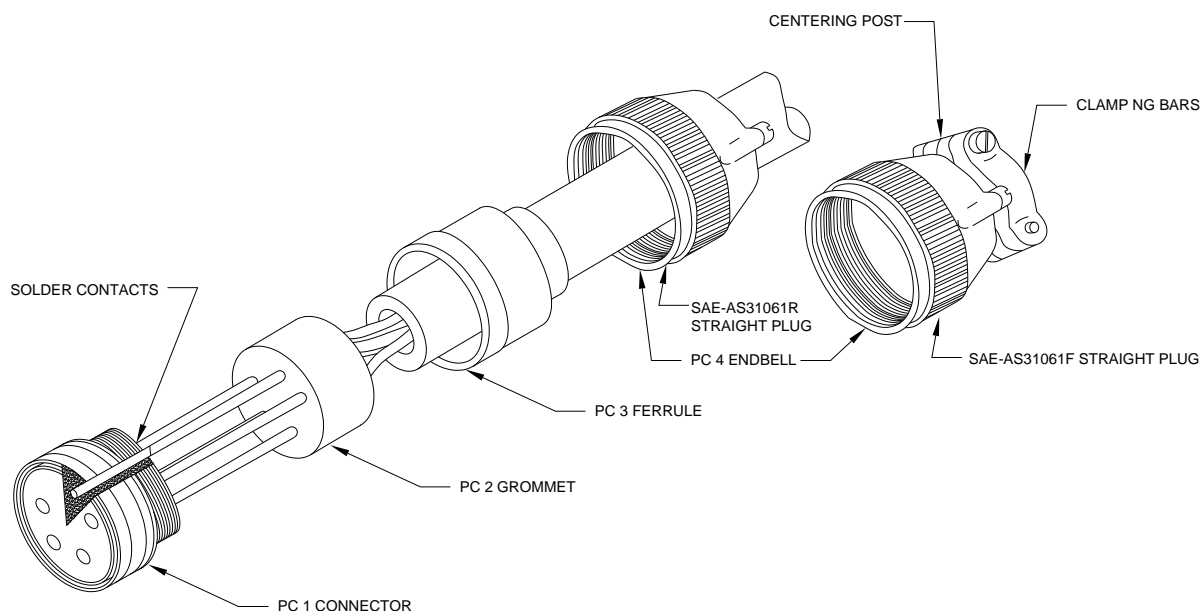

ILLUSTRATION 1
TYPICAL CONNECTOR/BACKSHELL
CONFIGURATION

- e. Visually inspect the components for damage such as deformed parts, gouges, damaged threads, cut O-rings, burrs, or surface damage.
 - f. If the conductors are re-twisted during lead preparation, ensure they are twisted as tight as originally constructed, the natural lay of the conductor is maintained, and the conductors will fit inside the contact barrel.
2. Prepare the cable in accordance with [figure 5A1](#).
- a. The grommet (PC 2) is designed to fit around individual conductors and therefore cannot be placed on the cable until individual conductors have been exposed in the cable.

FIGURE 5C1. MIL-DTL-5015/SAE-AS50151 solder connector assembly procedure.

MIL-STD-2003-5B(SH)
APPENDIX 5C

MIL-DTL-5015/SAE-AS50151 solder connector assembly procedure (continued):

3. Insertion set-up: Owing to the many possible variations of acceptable designs for an assembly fixture, no specification is made as to a particular type. The components that are desirable for an acceptable assembly fixture are as follows: A dummy receptacle, without connector insert, to hold the connector being worked on securely, or a clamping device that will not damage the connector; a cable clamping fixture (see illustration 2) to hold the cable in a secure, fixed relationship to the connector while permitting access to the rear face of the connector for the soldering iron; a device for holding the wire bundle out of the work area. Use of this fixture may negate the need for a dummy receptacle, which may affect the following steps.

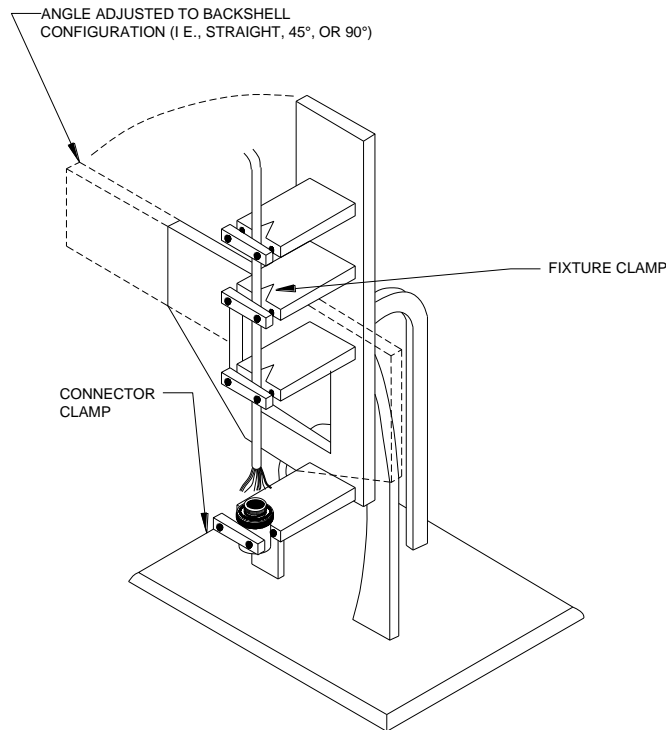

ILLUSTRATION 2
ASSEMBLY FIXTURE

- a. Secure the assembly fixture to a vise or similar holding device in order to provide a stable work area.
- b. Ensure the dummy receptacle (see illustration 3) meets the requirements of MS3105/SAE-AS31051 and is the correct size for the connector being assembled.

FIGURE 5C1. MIL-DTL-5015/SAE-AS50151 solder connector assembly procedure – Continued.

MIL-STD-2003-5B(SH)
APPENDIX 5C

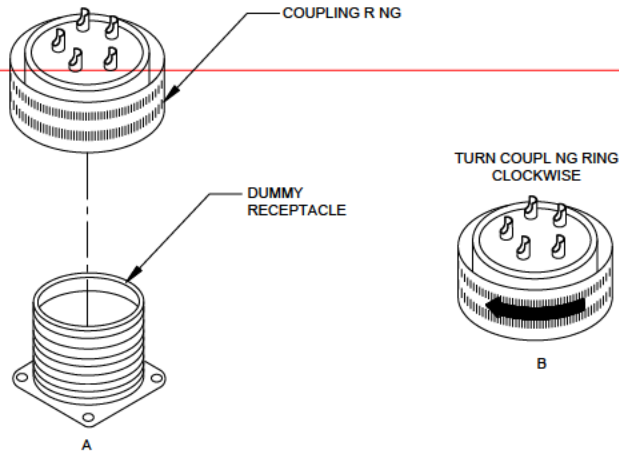

ILLUSTRATION 3
MATING CONNECTOR TO
DUMMY RECEPTACLE

MIL-DTL-5015/SAE-AS50151 solder connector assembly procedure (continued):

- c. Mate the connector to the dummy receptacle and tighten (see 4.5) the coupling ring (see illustration 3B).
4. Prepare the connector and cable for soldering as follows:
 - a. Insert the dummy receptacle with attached connector into the assembly fixture. Secure the connector in the assembly fixture.
 - b. Place the prepared cable in the fixture clamp so that the first contacts to be soldered will be at the back of the connector as it is held in the dummy receptacle.
 - c. Position the cable at an angle similar to the backshell design (i.e., 45 degrees, 90 degrees, or straight). Secure the cable in the fixture clamp (see illustration 4A).
 - d. Position the connector so that the connector to cable jacket distance is that measured in step 9.b of [figure 5A1](#). Rotate the connector to align the keyway position in proper relationship to the backshell (see illustration 4B).

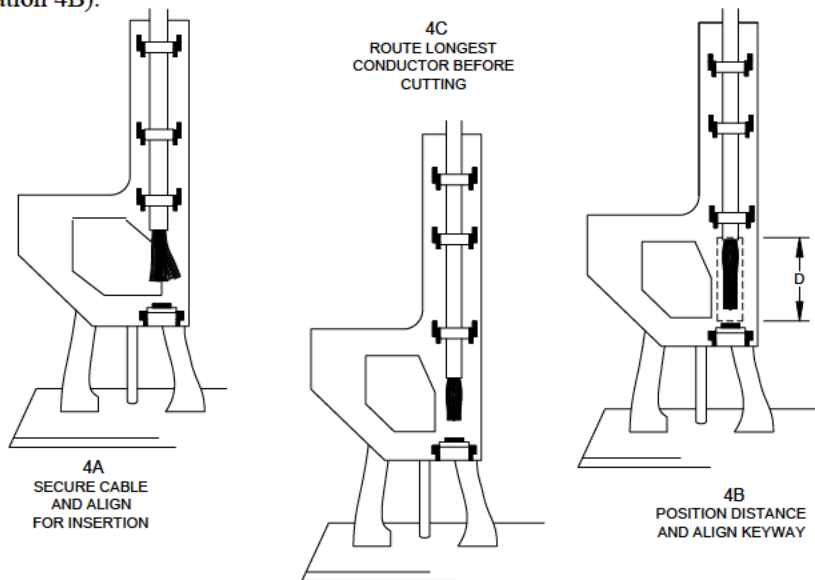

ILLUSTRATION 4
DETERMINING CONDUCTOR LENGTH

FIGURE 5C1. MIL-DTL-5015/SAE-AS50151 solder connector assembly procedure – Continued.

MIL-STD-2003-5B(SH)
APPENDIX 5C

MIL-DTL-5015/SAE-AS50151 solder connector assembly procedure (continued):

- e. Route the individual conductors per the applicable wiring table. Ensure that the longest routed conductor has sufficient length at the required position termination prior to cutting any conductor (see illustration 4C).
 - f. Cut the conductors as required to provide even conductor lengths at the connector insert.
NOTE: Leave the spares full length.
5. Insert conductors into proper holes of grommet (PC 2). Position the grommet next to the cable jacket.

TABLE 5C1-I. Wire barrel contact depth.

Contact size	Wire barrel depth
	+0.063 -0.000
0	0.625
4	0.625
8	0.500
12	0.375
16	0.250

6. Strip the individual conductors in accordance with [figure 5A3](#) (for contact wire barrel depths, see [table 5C1-I](#)).
7. Tin the conductors in accordance with [figure 5A5](#).
 - a. Ensure conductor strands are twisted tight prior to tinning.
 - b. If rework shortens a conductor's initial length by greater than ¼ inch, the jacket shall be cut back again and all leads re-trimmed and tinned to preclude stress.
8. Solder the conductors to the contacts in accordance with [figure 5A6](#). Soldering should start with the contact row(s) furthest away from the operator.
WARNING: Do not move the conductor after the soldering iron has been removed or a cold solder joint could result.

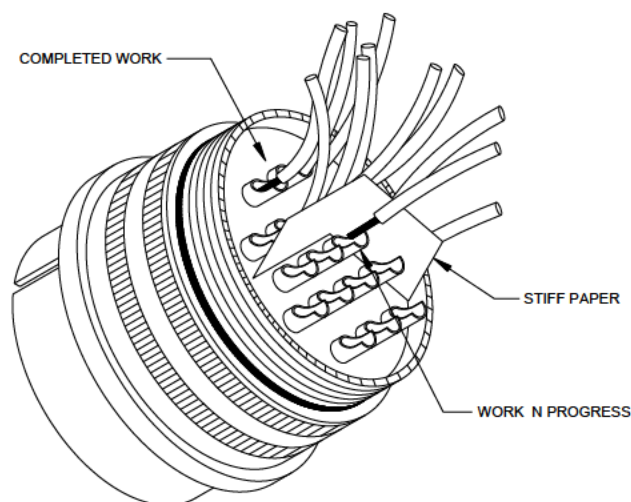

ILLUSTRATION 5
PROTECTING SOLDERED CONTACTS

FIGURE 5C1. MIL-DTL-5015/SAE-AS50151 solder connector assembly procedure – Continued.

MIL-STD-2003-5B(SH)
APPENDIX 5C

MIL-DTL-5015/SAE-AS50151 solder connector assembly procedure (continued):

9. A piece of stiff fire-retardant paper should be inserted between the rows as they are completed to aid in protecting the work already accomplished (see illustration 5 for example).
10. Remove the cable and connector from the assembly fixture and dummy receptacle.
11. Conduct a final visual check of the connector and verify wire location against the wiring table. Ensure no debris is inside socket contacts.

12. Backshell assembly:

NOTE: The following assembly procedure is based on the nomenclature and hardware configuration depicted in illustration 1. Variations may occur and cause minor deviations from this procedure. If this situation occurs, the manufacturer's assembly instructions should be followed.

- a. Slide the grommet (PC 2) over the contacts so that it is flush with the connector insert.
- b. Fill all empty grommet holes of class E, F, and R connectors with sealing plugs corresponding to MS3187 or MS27488.
- c. Fold spare wires back one-half the distance between the connector and the jacket end.
- d. Slide a 1-inch long piece of ¼-inch shrink tubing over each folded pair and shrink in place.
- e. Lightly coat the threads of the endbell (PC 4) with petroleum jelly just prior to assembly.
- f. Place the ferrule (PC 3) and endbell (PC 4) over the grommet. Tighten appropriately (see 4.5).
NOTE: Connectors manufactured by the Bendix Corporation shall be tightened until a metal-to-metal seat between the endbell and the connector body is established.
- g. Alternately tighten the clamping bar screws until a minimum gap of not less than ⅙ inch exists between the clamp support and clamp saddles (see illustration 6) (see 4.5).
NOTE: If required, install personnel safety ground under clamping bar screw.

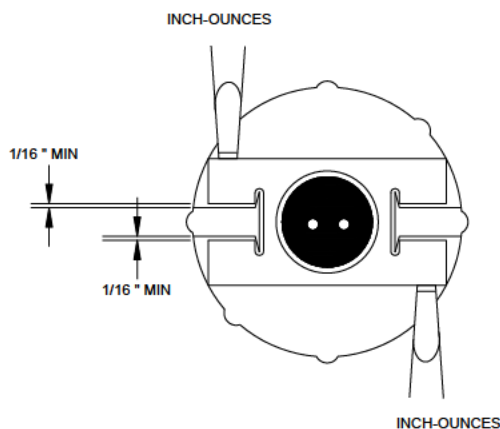

ILLUSTRATION 6

13. Final test and documentation:

- a. Perform electrical/electronic checks on the assembled connector (see 4.5).
 - b. Install a protective dust cap on the connector.
 - c. Complete the assembly inspection and documentation as required by local procedures.
14. If necessary, lockwire the connector in accordance with [figure 5A9](#).

FIGURE 5C1. MIL-DTL-5015/SAE-AS50151 solder connector assembly procedure – Continued.

MIL-STD-2003-5B(SH)
APPENDIX 5C

MIL-DTL-5015/SAE-AS50151 (crimp) connector assembly procedure:

Applicable connectors: MIL-DTL-5015 and associated MS specifications sheets are cancelled and superseded by SAE-AS50151 and associated subordinate SAE specifications (see C.1.1) . The procedures in this appendix specifically cover assembly of connectors in accordance with the following specification sheets and subordinate specifications of MIL-DTL-5015 and SAE-AS50151. This appendix may also be used to assemble connectors in accordance with other specification sheets and subordinate specifications of MIL-DTL-5015 and SAE-AS50151. Installation of other connectors covered in specifications subordinate to the main specification in this appendix shall use the installation requirements in this appendix to the maximum extent practicable.

MS3401/SAE-AS34011

MS3406/SAE-AS34061

MS3408/SAE-AS34081

MS3451/SAE-AS34511

MS3456/SAE-AS34561

MS3459/SAE-AS34591

MS3402/SAE-AS34021

10-2141 series

10-2146 series

10-2148 series

10-2149 series

NOTE: This procedure covers the MS3400 series/SAE-AS34001 series (front release crimp contact) and the MIL-DTL-5015/SAE-AS50151 (modified) connectors (Bendix 10-214 series, or equal [see 4.2], front release contacts).

1. Visual inspection and verification:
 - a. Disassemble the connector/backshell assembly.
 - b. Verify that the connector is of the correct type and configuration for the cable being terminated in accordance with the system cabling diagram.
 - c. Verify that the backshell configuration is of the correct type as specified on the system cabling diagram.
 - d. Verify that all component parts of the connector and backshell hardware are present. (See illustration 1 for a typical connector/backshell configuration.)
Reference: MIL-DTL-5015/SAE-AS50151 for connector, SAE-AS85049 for backshell, or vendor data for specific configurations.
 - e. Visually inspect the components for damage such as deformed parts, gouges, damaged threads, cut O-rings, burrs, or surface damage.
 - f. Verify that front-release contacts meet the requirements of SAE-AS39029/44 for pin and SAE-AS39029/45 for socket contacts.
 - g. Verify that the rear-release contacts meet the requirements of SAE-AS39029/29 for pin and SAE-AS39029/30 for socket contacts.
 - h. Verify that the contacts for MIL-DTL-5015/SAE-AS50151 modified connectors are 10-113239 series for shell size 8S-40 and 10-313672 (10-313673 series for sockets) series for shell size 44-48 or are the equivalent current Bendix Corporation part numbers.
2. Prepare the cable in accordance with [figure 5A1](#).
NOTE: The backshell configurations depicted in illustrations 1A and 1B are interchangeable between connector types (series).

FIGURE 5C2. MIL-DTL-5015/SAE-AS50151 (crimp) connector assembly procedure.

MIL-STD-2003-5B(SH)
APPENDIX 5C

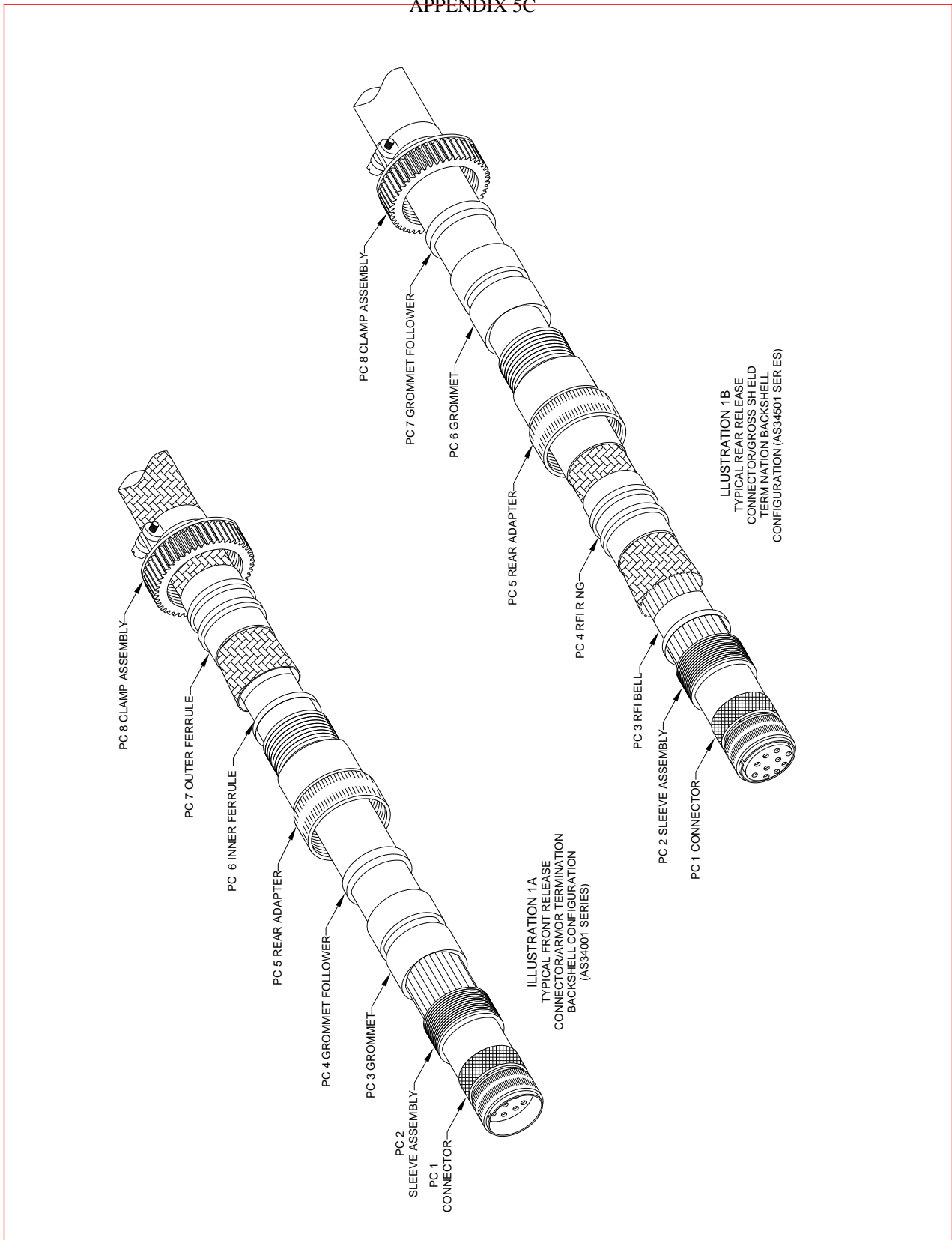

FIGURE 5C2. MIL-DTL-5015/SAE-AS50151 (crimp) connector assembly procedure – Continued.

MIL-STD-2003-5B(SH)
APPENDIX 5C

MIL-DTL-5015/SAE-AS50151 (crimp) connector assembly procedure (continued):

3. Insertion set-up: Owing to the many possible variations of acceptable designs for an assembly fixture, no specification is made as to a particular type. The components that are desirable for an acceptable assembly fixture are as follows: A dummy receptacle, without connector insert, to hold the connector being worked on securely or a clamping device that will not damage the connector; a cable-clamping fixture to hold the cable in a secure, fixed relationship to the connector while permitting access to the rear face of the connector for the contact insertion tool (see illustration 2); a device for holding the wire bundle out of the work area.

NOTE: Equivalent tooling is acceptable; however, the use of other tools may affect the procedural steps outlined below.

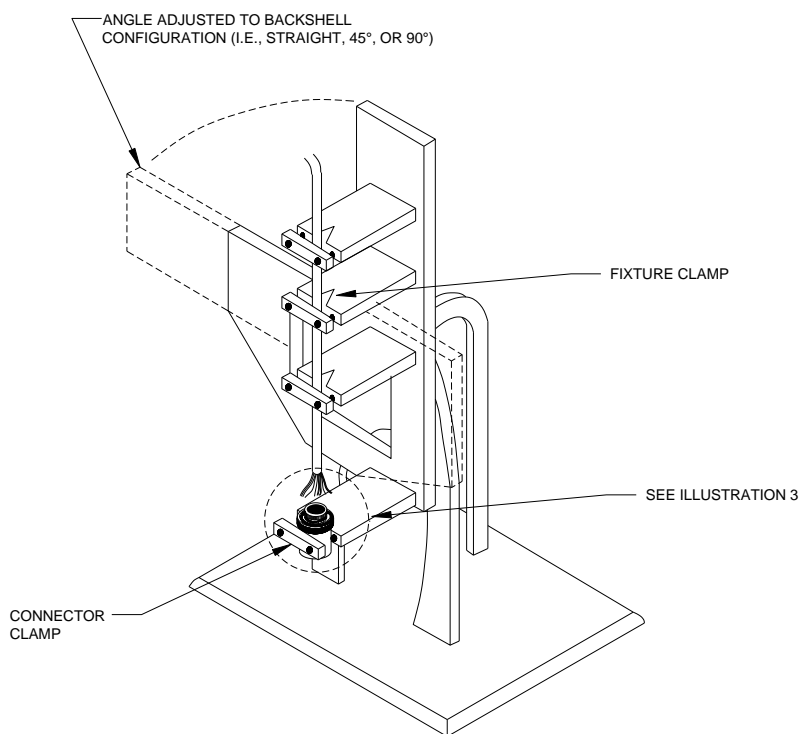

ILLUSTRATION 2
ASSEMBLY FIXTURE

- Secure the assembly fixture to a vise or similar holding device in order to provide a stable work area.
- Use of this assembly fixture negates the need for a dummy receptacle. Illustration 3 illustrates how the connector is firmly seated in the connector clamp.
- Seat the connector in the connector clamp and adjust the wing nuts to secure it in place.
- Place the prepared cable in the fixture clamp so that the first contacts to be inserted will be at the back of the connector as it is held in the connector clamp.
- Position the cable at the angle similar to the backshell design (i.e., 45 degrees, 90 degrees, or straight). Secure the cable in the fixture clamp (see illustration 4A).

FIGURE 5C2. MIL-DTL-5015/SAE-AS50151 (crimp) connector assembly procedure – Continued.

MIL-STD-2003-5B(SH)
APPENDIX 5C

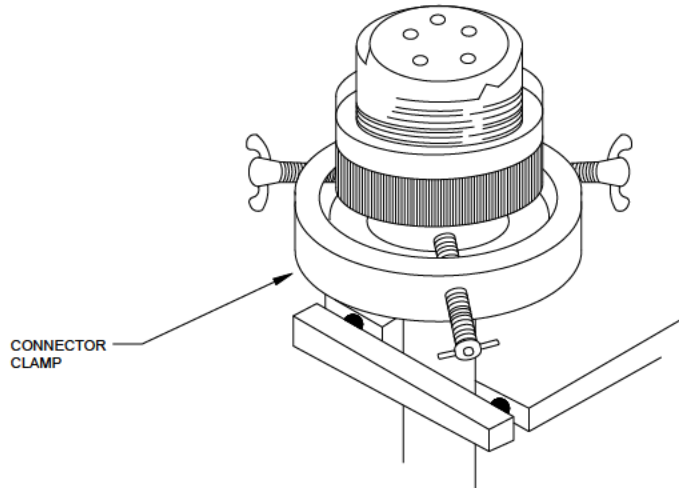

ILLUSTRATION 3
CONNECTOR SEATED IN ASSEMBLY FIXTURE

MIL-DTL-5015/SAE-AS50151 (crimp) connector assembly procedure (continued):

- f. Position the connector so that the connector cable jacket distance is that measured in step 9.b of [figure 5A1](#). Rotate the connector to align the keyway position in proper relationship to the backshell (see illustration 4B).
- g. Route the individual conductors in accordance with the applicable wiring table. Ensure that the longest routed conductor has sufficient length at the required position termination prior to cutting any conductor (see illustration 4C).

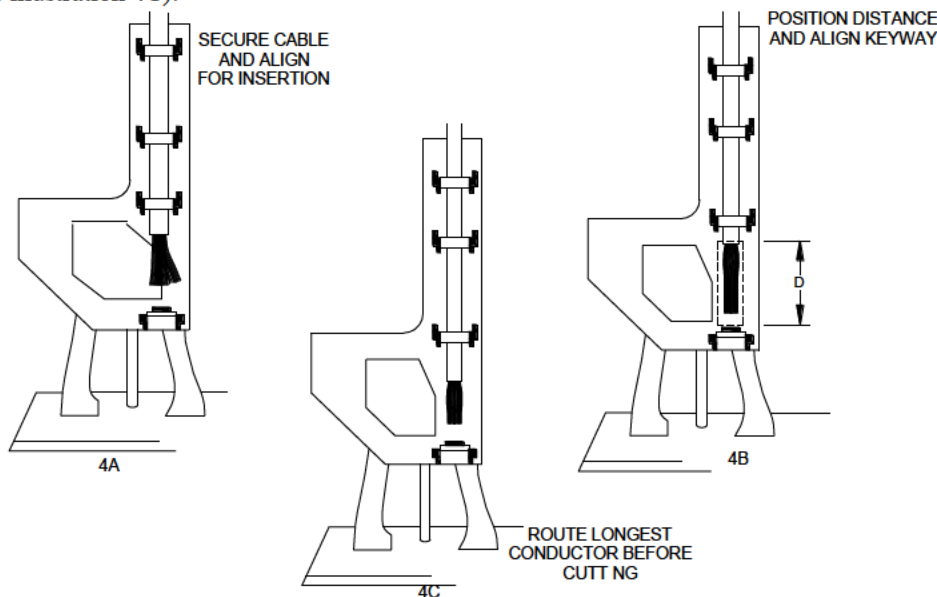

ILLUSTRATION 4
DETERMINING CONDUCTOR LENGTH

- h. Cut the conductors as required to provide even conductor lengths at the conductor insert.
NOTE: Leave the spares full length.
4. Strip the individual conductors in accordance with [figure 5A3](#) (for contact wire barrel depths, see [table 5C2-I](#)).

FIGURE 5C2. MIL-DTL-5015/SAE-AS50151 (crimp) connector assembly procedure – Continued.

MIL-STD-2003-5B(SH)
APPENDIX 5C

TABLE 5C2-I. Wire barrel contact depth.

Contact barrel size	Wire barrel depth (inch)	
	Front release	Rear release
0	0.636–0.690	0.610–0.630
4	0.484–0.534	0.485–0.516
8	0.484–0.534	0.485–0.516
12	0.250–0.261	0.250–0.266
16	0.250–0.261	0.250–0.266
20	0.250–0.270	N/A

MIL-DTL-5015/SAE-AS50151 (crimp) connector assembly procedure (continued):

5. Terminate individual conductors with crimp contacts in accordance with [figure 5A4](#) (see [table 5C2-II](#) for proper crimping tool). If contact rework shortens a conductor's initial length by greater than ¼ inch, the jacket shall be cut back again and all conductors re-trimmed to preclude stress.

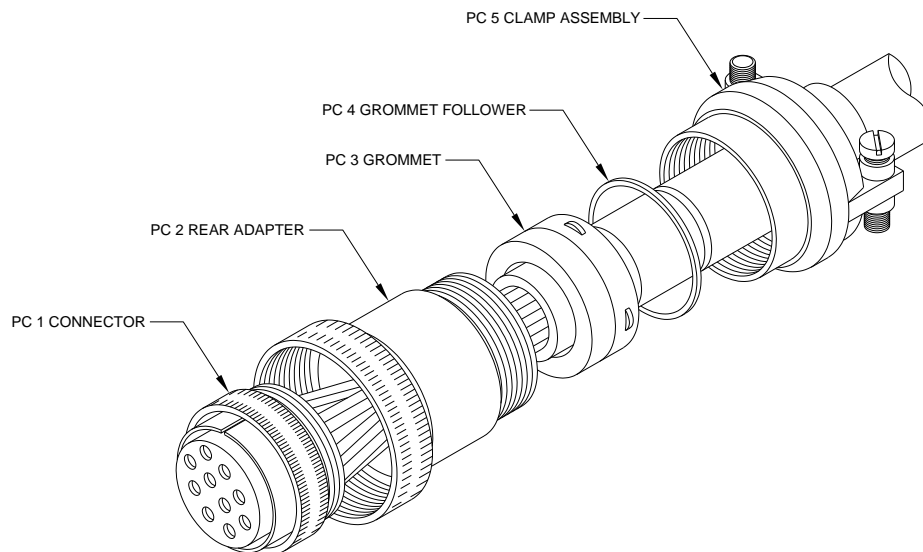

ILLUSTRATION 5
TYPICAL SAE-AS50151 (MOD F ED)
CONNECTOR/BACKSHELL CONFIGURATION

FIGURE 5C2. MIL-DTL-5015/SAE-AS50151 (crimp) connector assembly procedure – Continued.

MIL-STD-2003-5B(SH)
APPENDIX 5CTABLE 5C2-II. Front release.

Contact size	Basic crimping tool	Positioner	Die set	Locator
0-0	M22520/23-01	--	M22520/23-05	M22520/23-13
4-4	M22520/23-01	--	M22520/23-04	M22520/23-11
8-8	M22520/23-01	--	M22520/23-02	M22520/23-09
12-12	M22520/1-01	M22520/1-02 yellow	--	--
12-16	M22520/1-01	M22520/1-02 yellow	--	--
16-16	M22520/1-01	M22520/1-02 blue	--	--
16-20	M22520/1-01	M22520/1-02 blue	--	--

NOTE: See [table 5C2-IV](#) for MIL-DTL-5015/SAE-AS50151 modified connector.

TABLE 5C2-III. Rear release.

Contact size	Basic crimping tool	Positioner	Die set	Locator
0-0	M22520/23-01	--	M22520/23-05	M22520/23-13
4-4	M22520/23-01	--	M22520/23-04	M22520/23-11
8-8	M22520/23-01	--	M22520/23-02	M22520/23-09
12-12	M22520/1-01	M22520/1-02 yellow	--	--
12-16	--	--	--	--
16-16	M22520/7-01 M22520/1-01	M22520/17-03 M22520/1-02 blue	--	--
16-22	--	--	--	--

MIL-DTL-5015/SAE-AS50151 (crimp) connector assembly procedure (continued):

6. Inserting contacts:
 - a. Using the proper wiring table, proper inserting tool based on contact type (see [table 5C2-III](#)), and working from the rear to the front of the assembly fixture, insert the contacts into their designated locations in the connector as follows:

FIGURE 5C2. MIL-DTL-5015/SAE-AS50151 (crimp) connector assembly procedure – Continued.

MIL-STD-2003-5B(SH)
APPENDIX 5C

TABLE 5C2-IV. Tools for modified MIL-DTL-5015/SAE-AS50151 connectors.

Contact size	Front release		Rear release	
	Insertion tool	Removal tool	Insertion tool	Removal tool
0-0	M81969/17-08	M81969/19-05	--	M81969/29-04
4-4	M81969/17-07	M81969/19-04	--	M81969/29-03
8-8	M81969/17-06	M81969/19-03	--	M81969/29-02
12-12	M81969/17-02	M81969/19-02	M81969/14-04	M81969/14-04
12-16	M81969/17-01	M81969/19-01	--	--
16-16	M81969/17-01	M81969/19-01	M81969/14-03	M81969/14-03
16-22	M81969/17-01	M81969/19-01	--	--

NOTE: See [table 5C2-V](#) for MIL-DTL-5015/SAE-AS50151 modified connector.

MIL-DTL-5015/SAE-AS50151 (crimp) connector assembly procedure (continued):

NOTE: For MIL-DTL-5015/SAE-AS50151 modified connectors with socket contacts, install socket contact pilot pins in the connector (see [table 5C2-IV](#)). Proceed to step 6.a(4) for contact insertion procedure.

- (1) Insert a wired contact into the rear of the insert.
- (2) Seat the contact by positioning the insertion tool around the rear of the contact shoulder with a slight angle toward the contact to assure a firm grip (see illustration 6).

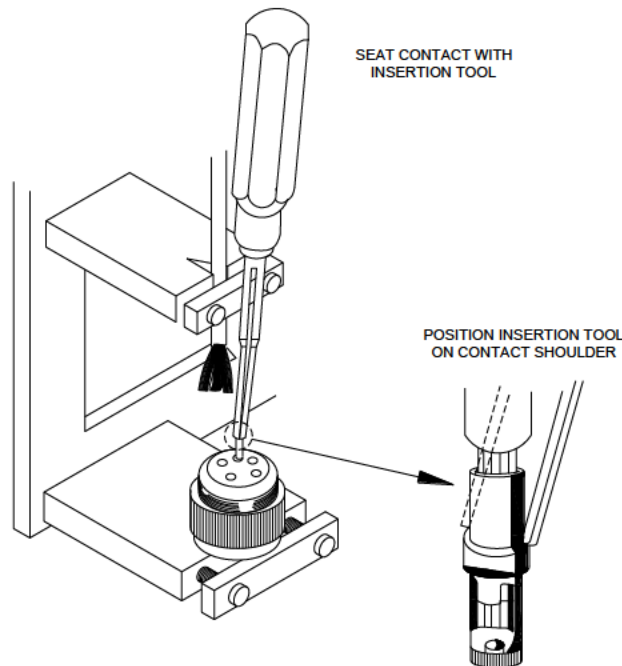

ILLUSTRATION 6
CONTACT INSERTION

FIGURE 5C2. MIL-DTL-5015/SAE-AS50151 (crimp) connector assembly procedure – Continued.

MIL-STD-2003-5B(SH)
APPENDIX 5C

MIL-DTL-5015/SAE-AS50151 (crimp) connector assembly procedure (continued):

- (a) Push the contact straight into the connector with a firm, steady pressure until the contact bottoms.
- (b) The contact shoulder provides a positive stop.
- (3) Move the insertion tool back away from the contact before sliding it straight up along the wire insulation until it clears the insert. Lightly pull on inserted conductor to ensure contact has locked in connector.
- (4) Insert contacts into the MIL-DTL-5015/SAE-AS50151 modified connector as follows:
WARNING: Contacts (size 16) are fragile compared to the contact insertion force. Care shall be exercised to avoid bending the contacts. Bent contacts shall be replaced.
 - (a) Grip the contact with the insertion tool located close to the contact engaging end (see illustration 7).
 - (b) Using straight, forward motion, push the wired contact into the appropriate cavity of the insert until the tool tip is in contact with the insert.
 - (c) Reposition the insertion tool behind the rear shoulder of the contact (see illustration 8).

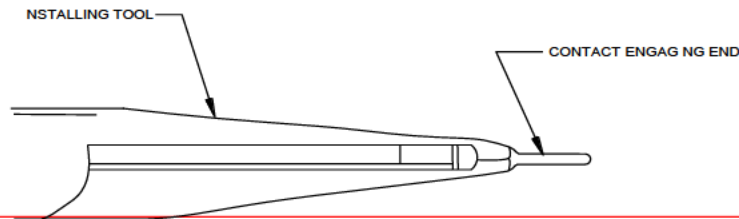

ILLUSTRATION 7
CONTACT INSERTION

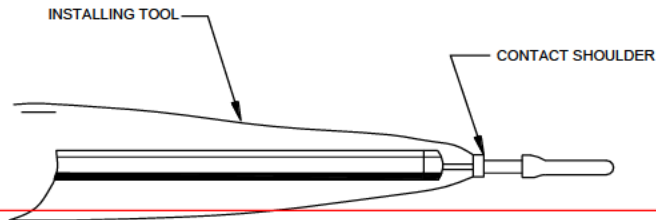

ILLUSTRATION 8
CONTACT INSERTION

- (d) Push the contact into the insert until seated.
- (e) Remove the insertion tool by moving it back away from the contact before sliding it straight up along the wire insulation until it clears the insert.
- (f) Lightly pull on inserted lead to ensure contact has locked in connector.
- (5) Adjust the fixture clamp as required during the insertion process to ease stress on the conductors.
- (6) Ensure that the shield ground wire (if terminated to a contact) is inserted in its proper location.
- (7) Upon insertion of each two rows of contacts, visually inspect the connector face to ensure that the contacts are properly inserted.
- (8) Insert unwired contacts into all empty holes in the connector insert utilizing steps 6.a(1) through 6.a(4).
- (9) Insert sealing plugs, if required, meeting the requirements of MS3187 or MS27488 into all unwired contact holes. Sealing plugs are required for environmental connectors, but not for non-environmental connectors.
- b. Conduct a visual check of the connector and verify wire location against the wiring table. Ensure no debris is inside socket contacts.

FIGURE 5C2. MIL-DTL-5015/SAE-AS50151 (crimp) connector assembly procedure – Continued.

MIL-STD-2003-5B(SH)
APPENDIX 5C

TABLE 5C2-V. Bendix part numbers.

Contact size	Crimping tool	Positioner	Insertion tool	Extraction* tool tip		Socket contact pilot pin	Wire strip length (in)
				Pin	Socket		
16	11-7295	11-7771	11-7345	11-3697	11-3698	10-242758-16	5/16
12	11-7295	11-7771	11-7082	11-3676	11-3698	10-242758-12	5/16
8	11-7838-1	11-7740-6 (locator)	11-8220	11-8252	11-8251	10-242758-8	9/16

NOTE: Extraction tool tips are used in conjunction with the 11-6911 handle assembly.

MIL-DTL-5015/SAE-AS50151 (crimp) connector assembly procedure (continued):

7. Contact removal procedure (as required):
 - a. Conduct a visual inspection of the connector face to identify any unseated contacts.
 - b. Remove the connector from the connector clamp, and using the extraction tool, remove any unseated contacts as follows:
 - (1) Front release (MS3400/SAE-AS34001 series):
 - (a) Select the correct removal tool from [table 5C2-IV](#).

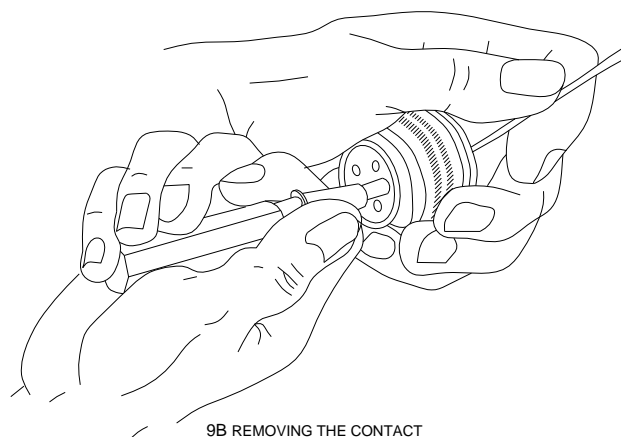
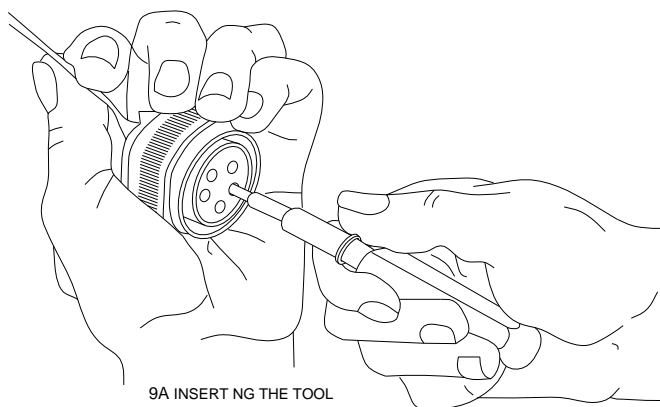

ILLUSTRATION 9
CONTACT REMOVAL (FRONT RELEASE)

FIGURE 5C2. MIL-DTL-5015/SAE-AS50151 (crimp) connector assembly procedure – Continued.

MIL-STD-2003-5B(SH)
APPENDIX 5C

MIL-DTL-5015/SAE-AS50151 (crimp) connector assembly procedure (continued):

- (b) Enclose the front of the contact with the extraction tool (see illustration 9A).
- (c) Push with the rear of the tool and fully bottom the tool tip by slightly rotating the rear of the tool in a clockwise direction.
- (d) With the tool tip bottomed, push the thrust sleeve forward moving the contact back through the sealing barriers (see illustration 9B).

NOTE: For size 8 wire and larger, assist the tool by pulling back on the wire while using the thrust sleeve.

(2) Rear release (MS3450/SAE-AS34501 series):

- (a) Select the correct removal tool from [table 5C2-IV](#).
- (b) Lay the wire of the contact to be removed along the slot of the tool leaving ½ inch from the end of the tool to the rear of the connector (see illustration 10A).
- (c) Squeeze the wire firmly into the tool between the thumb and forefinger about ½ inch from the tip (see illustration 10A).

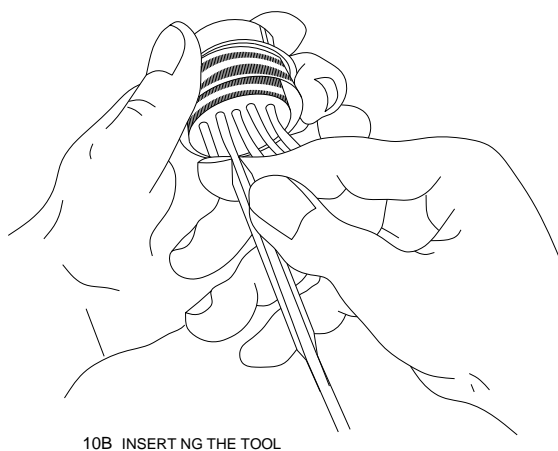
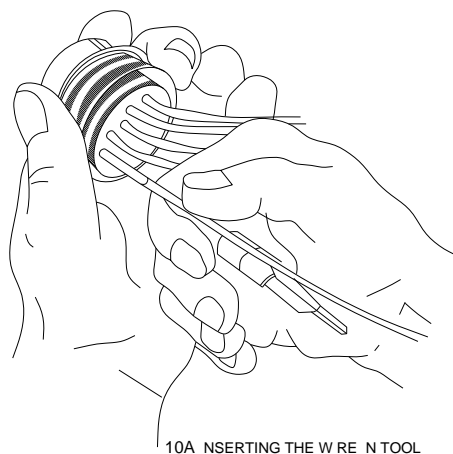

ILLUSTRATION 10
CONTACT REMOVAL (REAR RELEASE)

FIGURE 5C2. MIL-DTL-5015/SAE-AS50151 (crimp) connector assembly procedure – Continued.

MIL-STD-2003-5B(SH)
APPENDIX 5C

MIL-DTL-5015/SAE-AS50151 (crimp) connector assembly procedure (continued):

- (d) Slide the tool down along the wire and into the rear cavity and slowly around the contact until a positive resistance is felt (see illustration 10B). Continue until the tool is bottomed, unlocking connector contact retention fingers.
NOTE: Do not rotate the tool as this may damage the insert.
- (e) Pull both the tool and contact assembly out of the connector.
- (3) MIL-DTL-5015/SAE-AS50151 modified (10-214 series):
 - (a) Select the correct removal tool from [table 5C2-V](#).
 - (b) Position the tool tip in socket or pin over the mating (front) end of the contact to be removed.
 - (c) Push the contact through the insert.
 - (d) Remove the removal tool and inspect the connector insert for damage.
- c. Reinsert all extracted contacts.
- d. If a contact fails to reseat after three insertion attempts, replace the offending contact. If the same contact location continues to give difficulty, the connector is probably damaged or faulty and should be replaced.
- e. Remove the connector from the connector clamp if not previously accomplished.
- 8. Backshell assembly:

NOTE: The following assembly procedure is based on the nomenclature and hardware configuration depicted in illustration 1. Variations may occur and cause minor deviations from this procedure. If this situation occurs, the manufacturer's assembly instructions should be followed.

 - a. Fold spare wires back one-half the distance between the connector and the jacket end.
 - b. Slide a 1-inch long piece of appropriately sized shrink tubing over each folded pair and shrink in place.
 - c. Lightly coat the thread of each backshell part with petroleum jelly just prior to using.
 - d. Position and lubricate all O-rings.
 - e. Loosen the fixture clamp on the assembly fixture.
 - f. Armor termination backshell configuration (see illustration 1A)

NOTE: If the cable is unarmored, exchange the grommet and grommet follower (PC 3 and 4 of illustration 1A) with the inner and outer ferrules (PC 6 and 7 of illustration 1A) in the assembly sequence. For gross shield termination backshell configuration (illustration 1B), proceed to step 8g.

 - (1) Slide the sleeve assembly (PC 2) down the cable and screw it on the connector plug (PC 1). Tighten the sleeve assembly appropriately for the shell size (see 4.5).
 - (2) Slide the grommet (PC 3) and grommet follower (PC 4) into the sleeve assembly. The cable jacket shall extend beyond the grommet seat in the sleeve to assure a proper cable-to-grommet seal.
 - (3) Engage the rear adapter (PC 5) with the sleeve assembly and tighten appropriately for the shell size (see 4.5).
 - (4) Slide the inner ferrule (PC 6) into the rear adapter (PC 5) and seat on the inner shoulder.
 - (5) Flare the armor, if present, over the inner shoulder.
 - (6) Gently force the armor, if present, toward the connector, until the armor covers the tapered surface of the inner ferrule.
 - (7) Insert the outer ferrule (PC 7) into the rear adapter. Compress the armor, if present, between the inner and outer ferrules with a twisting motion.
 - (8) Screw the cable clamp assembly (PC 8) onto the rear adapter and hand tighten.
 - (9) Tighten the cable clamp appropriately for the shell size (see 4.5).
 - (10) Proceed to step 8.g(11).

FIGURE 5C2. MIL-DTL-5015/SAE-AS50151 (crimp) connector assembly procedure – Continued.

MIL-STD-2003-5B(SH)
APPENDIX 5C

MIL-DTL-5015/SAE-AS50151 (crimp) connector assembly procedure (continued):

- g. Gross shield termination backshell configuration (see illustration 1B).
- (1) Slide the sleeve assembly (PC 2) down the cable and screw it on the connector plug (PC 1).
 - (2) Tighten the sleeve assembly appropriately (see 4.5).
 - (3) If the gross shield is to be floated or terminated to a connector contact, proceed to step 8.g(4). If the shield is to be terminated to the backshell RFI hardware, proceed as follows:
 - (a) Slide the RFI bell (PC 3) against the sleeve assembly.
 - (b) Flare the gross shield over the tapered end of the RFI bell.
 - (c) Gently force the cable toward the connector plug until the shield covers the tapered surface on the RFI bell.
 - (d) Slide the RFI ring (PC 4) onto the RFI bell while applying forward pressure on the cable.
 - (e) Compress the shield between the RFI bell and the RFI ring with a back-and-forth twisting forward motion on the RFI ring.
 - (4) Slide the RFI backshell components (PC 3 and 4) over the pigtails, looped ground wire, and spare conductors.
 - (5) Slide the rear adapter (PC 5) over the RFI assembly and screw it onto the sleeve assembly.
 - (6) Tighten the rear adapter appropriately for the shell size (see 4.5).
 - (7) Mark a line on the cable $\frac{1}{4}$ inch to $\frac{1}{2}$ inch above the backshell rear adapter (see illustration 11). Carefully push the cable into the backshell $\frac{1}{4}$ inch to $\frac{1}{2}$ inch and maintain continuous pressure to hold at this position for the next four steps. (Line marked on jacket is parallel with end of rear adapter.)

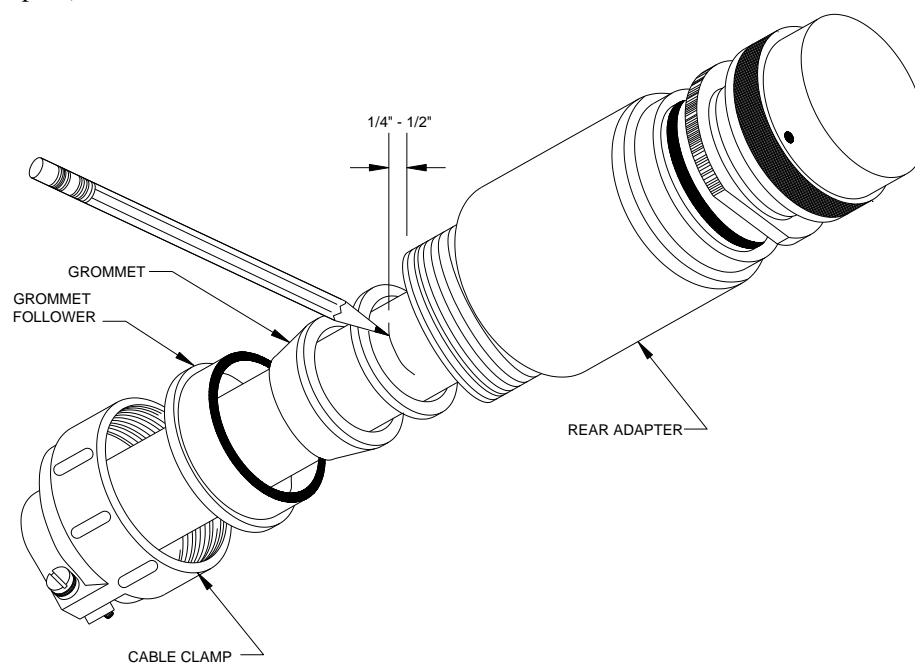

ILLUSTRATION 11
MARKING THE CABLE

- (8) Verify the cable jacket is positioned completely through the grommet.
- (9) Slide the grommet (PC 6) and grommet follower (PC 7) into position behind the rear adapter.
- (10) Screw the cable clamp (PC 8) onto the rear adapter and tighten appropriately (see 4.5).
- (11) Alternately tighten the clamping bar screws until the clamping bar is properly seated with a minimum gap of not less than $\frac{1}{16}$ inch between the clamp support and clamp saddles.
NOTE: If required, install personnel safety ground under clamping bar screw (see 4.5).
- (12) Remove the connector from the assembly fixture.

FIGURE 5C2. MIL-DTL-5015/SAE-AS50151 (crimp) connector assembly procedure – Continued.

MIL-STD-2003-5B(SH)
APPENDIX 5C

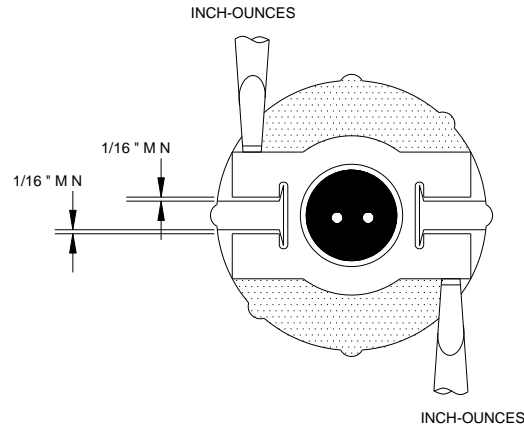

ILLUSTRATION 12

MIL-DTL-5015/SAE-AS50151 (crimp) connector assembly procedure (continued):

- (13) Proceed to step 9.
- h. MIL-DTL-5015/SAE-AS50151 modified connector (10-214 series) (see illustration 5):
- (1) Slide the rear adapter (PC 2) down the cable and screw it on the connector plug (PC 1).
 - (2) Tighten the rear adapter appropriately for the shell size (see 4.5).
 - (3) Mark a line on the cable $\frac{1}{4}$ inch to $\frac{1}{2}$ inch above the rear adapter (see illustration 11). Carefully push the cable into the rear adapter $\frac{1}{4}$ inch to $\frac{1}{2}$ inch and maintain continuous pressure to hold at this position for the next four steps. (Line marked on jacket is parallel with end of rear adapter.)
 - (4) Verify the cable jacket is positioned completely through the grommet.
 - (5) Slide the grommet (PC 3) and grommet follower (PC 4) into position behind the rear adapter.
 - (6) Screw the cable clamp (PC 5) onto the rear adapter and tighten appropriately (see 4.5).
 - (7) Alternately tighten the clamping bar screws until the clamping bar is properly seated with a minimum gap of not less than $\frac{1}{16}$ inch between the clamp support and clamp saddles (see 4.5).
NOTE: If required, install personnel safety ground under clamping bar screw.
 - (8) Remove the connector from the assembly fixture.
9. Final test and documentation:
- a. Perform electrical/electronic checks on the assembled connector (see 4.5).
 - b. Install a protective dust cap on the connector.
 - c. Complete the assembly inspection and documentation as required by local procedures.
10. If necessary, lockwire the connector in accordance with [figure 5A9](#).

FIGURE 5C2. MIL-DTL-5015/SAE-AS50151 (crimp) connector assembly procedure – Continued.

MIL-STD-2003-5B(SH)
APPENDIX 5C

Method 5C-3-1
Multi-Cable Connector Assembly using Grommets

1. Scope and restrictions:
 - a. This method for joining multiple cables into a connector is an alternative to the bifurcation method in [figure 5A11](#) of this standard. This method includes replacing the grommet delivered with the connector with grommets with two or more holes so that multiple jacketed cables can be inserted into the connector.
 - b. The use of this method is restricted to cables manufactured to MIL-DTL-24643. Other cables and connectors may make use of this method if approved by NAVSEA.
 - c. The use of this method is restricted to connectors manufactured to SAE-AS34061/MS3406 and SAE-AS34081/MS3408 versions of connectors manufactured in accordance with SAE-AS50151/MIL-DTL-5015. See C.1.1. The use of this method is further restricted to SAE-AS34061/MS3406 or SAE-AS34081/MS3408 connectors and backshells with the cable entry ranges listed in illustrations 2-13. Installation of other connector types may use this method if approved by NAVSEA.
 - d. The multi-cable grommets that replace the original connector grommets shall be Glenair, or equal (see 4.2) products. The Glenair multi-cable grommets and associated part numbers are shown in the illustrations for this method.
 - e. When ordering grommets, the insert plugs may be inserted in unused grommet ports as part of the order. For Glenair grommets, add P# to the grommet part number where “#” is the quantity of plugs needed. For example, the part number for a grommet with two plugs installed would be, 687-938-A-P2. Insert plugs may be ordered separately by adding an “S” at the end of the grommet part number. A typical grommet insert plug is shown in illustration 14.
2. Pre-assembly instructions:
 - a. Select the cable type from MIL-DTL-24643 and quantity of cables desired to enter a single connector assembly backshell. Determine the maximum diameter of the combined cables to select the “entry range” of a connector backshell clamp based on the maximum cable outer diameter dimensions specified in cable specifications.
 - b. Select a grommet from the choices in illustrations 2-13 based on the needed cable entry range from SAE-AS34061/MS3406 or SAE-AS34081/MS3408.
 - c. Use a small amount of silicone grease in accordance with SAE-AS8660 on the threaded surfaces of all connector assemblies during make up to reduce potential for binding and galling of connector threads.
 - d. The connector coupling ring, backshell, and clamp assembly shall be tightened by hand with threads bottomed out. Visually inspect the clamp assembly to ensure that the environmental seal is seated.
 - e. A small amount of silicone grease may be applied to the jacket of the incoming cables to aid in sliding the multi-port grommet down the cables and in seating the grommet in the backshell. Excess grease shall be wiped from the cables using a clean lint-free cloth.
 - f. When inserting the incoming cables into the multi-cable grommet, ensure the cable lines up with the corresponding connector hookup points. This provides easier assembly of the connector.
 - g. Insert plugs into grommet holes that will not be used for incoming cables if the grommet insert plugs are not pre-installed.
3. Connector assembly instructions:
 - a. All piece (PC) numbers listed in this procedure are from illustration 1.
 - b. Disassemble the connector assembly.
 - c. Discard the single-cable grommet that came with the connector. Substitute a Glenair, or equal (see 4.2) multi-cable grommet, PC 4. The multi-cable grommets are provided separately. The grommet shall be selected to fit snugly over the cable insulation.
 - d. Temporarily assemble PC 1, 2, and 3 and tighten the knurled screw rings.
 - e. Insert each of the incoming cables into the assembly assuring that each cable end is bottomed against the rear of PC 1 of the connector. Mark the cable jacket at the rear/open end of the backshell, PC 3.
 - f. Disassemble the backshell, PC 3 and the adapter, PC 2, from the connector, PC 1.

FIGURE 5C3. Multi-cable connector assembly using grommets.

MIL-STD-2003-5B(SH)
APPENDIX 5C

- g. Ensure the inner diameter of the clamp assembly, PC 6, can easily pass the incoming cables. See [figure 5A1](#) for instructions on clamping cables.
- h. Slide the clamp assembly, PC 6, and grommet follower, PC 5, over the incoming cable bundle. Insert each incoming cable into the correct port of the multi-cable grommet, PC 4.
- i. Verify the cable diameters are compatible with the size of the grommet hole as follows:
 - (a) Wipe the cable jacket with a solvent from [table 5A1-I](#) in order to remove grease, oil, dirt, and other debris.
 - (b) Assemble the backshell, PC 3, hardware to compress the grommet, PC 4, to the cable jackets.
 - (c) Attempt to push the backshell, PC 3, straight along the cables by applying moderate pressure. Do not twist. The backshell, PC 3, shall not move. If satisfactory sealing cannot be obtained, buildup the cable diameter in accordance with [figure 5A2](#).
- j. Slide the backshell, PC 3, and the adapter, PC 2 over the over the incoming cables. Ensure that the O-ring is in place in the adapter, PC 2, groove. Position these parts on the incoming cables such that the parts will not interfere with wiring the connector, PC 1.
- k. Cut and remove the jacket from each incoming cable at the mark made in step 3e. Cut and remove any tape, fillers, and core under the outer jacket of the cables.
- l. Prepare and connect incoming cable conductors in accordance with wiring instructions and the methods in appendix 1A of this standard.
- m. Slide the adapter, PC 2, down the incoming cable bundle and assemble into the connector, PC 1. Slide the backshell, PC 3, down the incoming cable bundle and assemble into the adapter, PC 2. Tighten both knurled screw rings securely (see 4.5).
- n. Slide the multi-cable grommet, PC 4, and grommet follower, PC 5, down the incoming cable bundle, and seat these parts in the open end of the backshell, PC 3.
- o. Loosen the cable clamp, PC 6, saddles. Slide the clamp assembly down the incoming cable bundle. Assemble the clamp to the backshell, PC 3, and tighten per instructions in [figure 5C2](#).
- p. Using the instructions in [figure 5C2](#), tighten the cable clamp, PC 6, screws until the saddles grip the cable bundle securely.

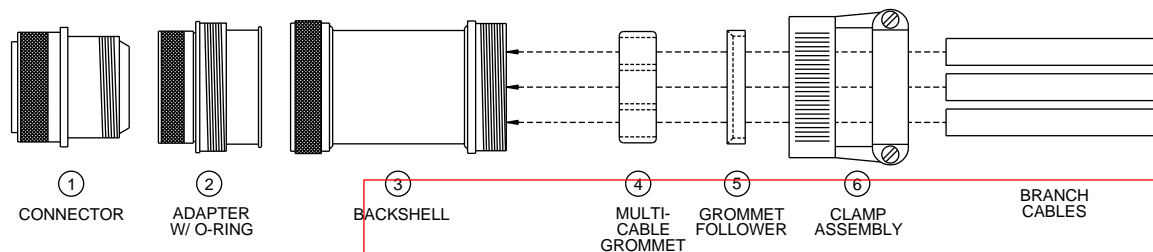
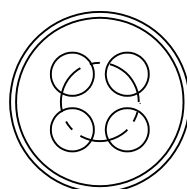

Illustration 1, Multi-Cable Connector Assembly



Glenair part number 687-938-A
Four ports
1.605-inch outer diameter
0.411-inch port inner diameter
0.75-inch diameter circle
Cable entry range – 0.875-1.25 inches

Illustration 2, Grommet, Glenair part number 687-938-A

FIGURE 5C3. Multi-cable connector assembly using grommets – Continued.

MIL-STD-2003-5B(SH)
APPENDIX 5C

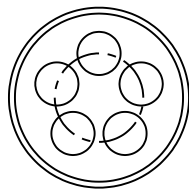

Glenair part number 687-938-B
Five ports
1.605-inch outer diameter
0.411-inch port inner diameter
0.81-inch diameter circle
Cable entry range – 0.875-1.25 inches

Illustration 3, Grommet, Glenair part number 687-938-B

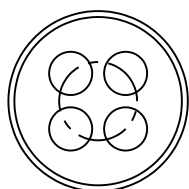

Glenair part number 687-938-C
Four ports
1.605-inch outer diameter
0.370-inch port inner diameter
0.75-inch diameter circle
Cable entry range – 0.875-1.25 inches

Illustration 4, Grommet, Glenair part number 687-938-C

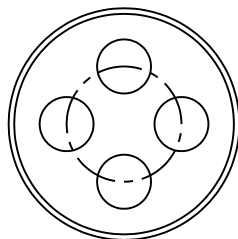

Glenair part number 687-938-D
Four ports
2.120-inch outer diameter
0.520-inch port inner diameter
1.064-inch diameter circle
Cable entry range – 1.25-1.625 inches

Illustration 5, Grommet, Glenair part number 687-938-D

FIGURE 5C3. Multi-cable connector assembly using grommets – Continued.

MIL-STD-2003-5B(SH)
APPENDIX 5C

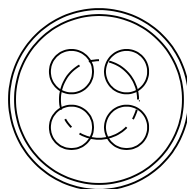

Glenair part number 687-938-E

Four ports

1.605-inch outer diameter

0.400-inch port inner diameter

0.75-inch diameter circle

Cable entry range – 0.875-1.25 inches

Illustration 6, Grommet, Glenair part number 687-938-E

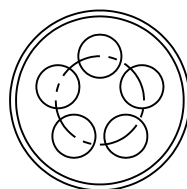

Glenair part number 687-938-F

Five ports

1.605-inch outer diameter

0.400-inch port inner diameter

0.81-inch diameter circle

Cable entry range – 0.875-1.25 inches

Illustration 7, Grommet, Glenair part number 687-938-F

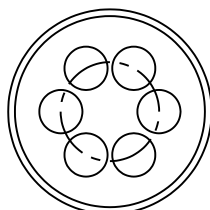

Glenair part number 687-938-G

Six ports

1.862-inch outer diameter

0.400-inch port inner diameter

0.94-inch diameter circle

Cable entry range – 1.0-1.375 inches

Illustration 8, Grommet, Glenair part number 687-938-G

FIGURE 5C3. Multi-cable connector assembly using grommets – Continued.

MIL-STD-2003-5B(SH)
APPENDIX 5C

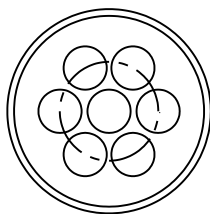

Glenair part number 687-938-H
Seven ports
1.862-inch outer diameter
0.400-inch port inner diameter
0.94-inch diameter circle

Cable entry range – 1.0-1.375 inches

Illustration 9, Grommet, Glenair part number 687-938-H

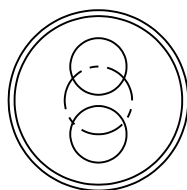

Glenair part number 687-938-I
Two ports
1.605-inch outer diameter
0.535-inch port inner diameter
0.62-inch diameter circle

Cable entry range – 0.875-1.25 inches

Illustration 10, Grommet, Glenair part number 687-938-I



Glenair part number 687-938-J
Two ports
1.050-inch outer diameter
0.300-inch port inner diameter
0.375-inch diameter circle

Cable entry range – 0.5-0.75 inches

Illustration 11, Grommet, Glenair part number 687-938-J

FIGURE 5C3. Multi-cable connector assembly using grommets – Continued.

MIL-STD-2003-5B(SH)
APPENDIX 5C

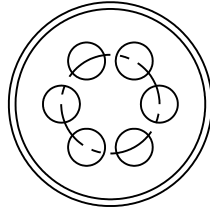

Glenair part number 687-938-K
Six ports
1.862-inch outer diameter
0.370-inch port inner diameter
~~0.94-inch diameter circle~~

Cable entry range – 1.0-1.375 inches

Illustration 12, Grommet, Glenair part number 687-938-K

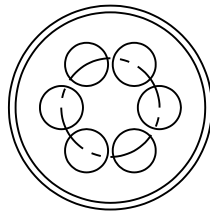

Glenair part number 687-938-L
Six ports
1.605-inch outer diameter
0.400-inch port inner diameter
0.94-inch diameter circle

Cable entry range – 0.875-1.25 inches

Illustration 13, Grommet, Glenair part number 687-938-L

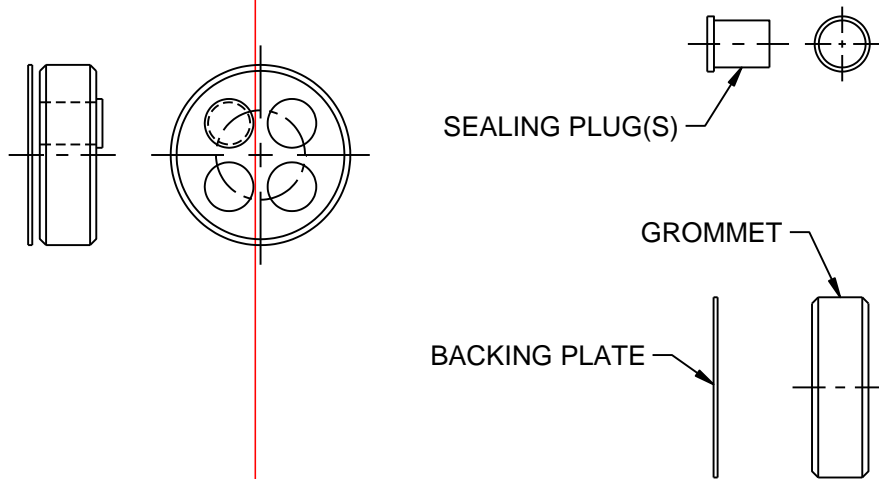

Illustration 14, Typical Glenair grommet plugs, grommet (side view), and backing plate

FIGURE 5C3. Multi-cable connector assembly using grommets – Continued.

MIL-STD-2003-5B(SH)
APPENDIX 5D

APPENDIX 5D – MIL-DTL-26482 CONNECTORS

D.1 SCOPE

D.1.1 Scope. This appendix describes procedures for the preparation of the MIL-DTL-26482 connector assembly. This appendix is a mandatory part of the standard. The information contained herein is intended for compliance.

D.2 APPLICABLE DOCUMENTS

D.2.1 General. The documents listed in this section are specified in this appendix. This section does not include documents cited in other sections of this standard or recommended for additional information or as examples. While every effort has been made to ensure the completeness of this list, document users are cautioned that they must meet all specified requirements of documents cited in this appendix, whether or not they are listed.

D.2.2 Government documents.

D.2.2.1 Specifications, standards, and handbooks. The following specifications, standards, and handbooks form a part of this document to the extent specified herein. Unless otherwise specified, the issues of these documents are those cited in the solicitation or contract.

DEPARTMENT OF DEFENSE SPECIFICATIONS

MIL-DTL-26482 - Connectors, Electrical, Circular, Miniature, Quick Disconnect, Environment Resisting, Receptacles and Plugs, General Specification for

(Copies of this document are available online at <https://quicksearch.dla.mil>.)

D.2.2.2 Other Government documents, drawings, and publications. The following other Government documents, drawings, and publications form a part of this document to the extent specified herein. Unless otherwise specified, the issues of these documents are those cited in the solicitation or contract.

MILITARY SPECIFICATION SHEETS

MS3111	-	Connectors, Plug, Electrical, Solder Type, Cable-Connecting, Bayonet Coupling, Series 1, Classes E, F, J and P (see 4.6)
MS3116	-	Connectors, Plug, Electrical, Solder Type, Straight, Bayonet Coupling, Series 1, Classes E, F, J and P (see 4.6)
MS3121	-	Connectors, Plug, Electrical, Crimp Type, Cable-Connecting, Bayonet Coupling, Series 1, Classes E, F and P (see 4.6)
MS3126	-	Connectors, Plug, Electrical, Crimp Type, Straight, Bayonet Coupling, Series 1, Classes E, F and P (see 4.6)
MS3470	-	Connectors, Receptacle, Electrical, Series 2, Crimp Type, Narrow Flange Mount, Bayonet Coupling, Classes A, D, L, T, W and K
MS3471	-	Connectors, Receptacle, Electrical, Series 2, Crimp Type, Cable Connecting, Bayonet Coupling, Classes A, D, L, T, W and K
MS3475	-	Connectors, Plug, Electrical, RFI Shielded, Series 2, Crimp Type, Bayonet Coupling, Classes A, D, L, T, W and K
MS3476	-	Connectors, Plug, Electrical, Series 2, Crimp Type, Bayonet Coupling, Classes A, D, L, T, W and K
MS27488	-	Plug, End Seal, Electrical Connector

(Copies of these documents are available online at <https://quicksearch.dla.mil>.)

MIL-STD-2003-5B(SH)
APPENDIX 5D

D.2.3 Non-Government publications. The following documents form a part of this document to the extent specified herein. Unless otherwise specified, the issues of these documents are those cited in the solicitation or contract.

SAE INTERNATIONAL

- SAE-AS31971 - Gage Pin for Socket Contact Engagement Test
- SAE-AS39029/4 - Contacts, Electrical Connector, Pin, Crimp Removable
(for MIL-DTL-26482 Series 2, AS81703 Series 3, MIL-DTL-83723 Series I and III, and MIL-DTL-83733 Connectors)
- SAE-AS39029/5 - Contacts, Electrical Connector, Socket, Crimp Removable
(for MIL-DTL-26482 Series 2, AS81703 Series 3, MIL-DTL-83723 Series I and III, MIL-DTL-83733 Connectors, MIL-DTL-12883/40, and /41 Relay Sockets)
- SAE-AS39029/31 - Contacts, Electrical Connector, Pin, Crimp Removable
(for MIL-DTL-26482 Series 1, MIL-DTL-26500 and MIL-DTL-26518 Connectors)
- SAE-AS39029/32 - Contacts, Electrical Connector, Socket, Crimp Removable
(for MIL-DTL-26482 Series 1, MIL-DTL-26500 and MIL-DTL-26518 Connectors)

(Copies of these documents are available online at www.sae.org.)

D.2.4 Order of precedence. Unless otherwise noted herein or in the contract, in the event of a conflict between the text of this document and the references cited herein, the text of this document takes precedence. Nothing in this document, however, supersedes applicable laws and regulations unless a specific exemption has been obtained.

D.3 REQUIRED EQUIPMENT AND MATERIALS

D.3.1 Required equipment and materials. The required equipment and materials are specified in the standard methods of this section.

D.4 NOTES AND PROCEDURES

D.4.1 Dimensions. For figures and tables in this appendix, all dimensions are in inches unless otherwise noted.

D.4.2 Figures. [Table 5DI](#) provides information for the figures in this appendix.

TABLE 5DI. Figures for MIL-DTL-26482 connector assembly preparation.

Figure number	MIL-DTL-26482 connector assembly procedures	Page
5D1	MIL-DTL-26482 connector assembly procedure	145

MIL-STD-2003-5B(SH)
APPENDIX 5D

MIL-DTL-26482 connector assembly procedure:

Applicable connectors: The procedures in this appendix specifically cover assembly of connectors in accordance with the following specification sheets and subordinate specifications of MIL-DTL-26482. This appendix may also be used to assemble connectors in accordance with other specification sheets and subordinate specifications of MIL-DTL-26482. Installation of other connectors covered in specifications subordinate to the main specification in this appendix shall use the installation requirements in this appendix to the maximum extent practicable.

MS3111 (see 4.6)
MS3116 (see 4.6)
MS3121 (see 4.6)
MS3126 (see 4.6)
MS3470
MS3471
MS3475
MS3476

NOTE: This procedure covers series 1 connectors, which have solder or front release crimp contacts, and series 2 connectors, which have rear release crimp contacts.

1. Visual inspection and verification:

- a. Disassemble the connector/backshell assembly.
- b. Verify that the connector is of the correct type and configuration for the cable being terminated in accordance with the system cabling diagram.
- c. Verify that the backshell configuration is of the correct type as specified on the system cabling diagram.
- d. Verify that all component parts of the connector and backshell hardware are present (see illustration 1 for a typical connector/backshell configuration).

Reference: MIL-DTL-26482 for connector and backshell configurations.

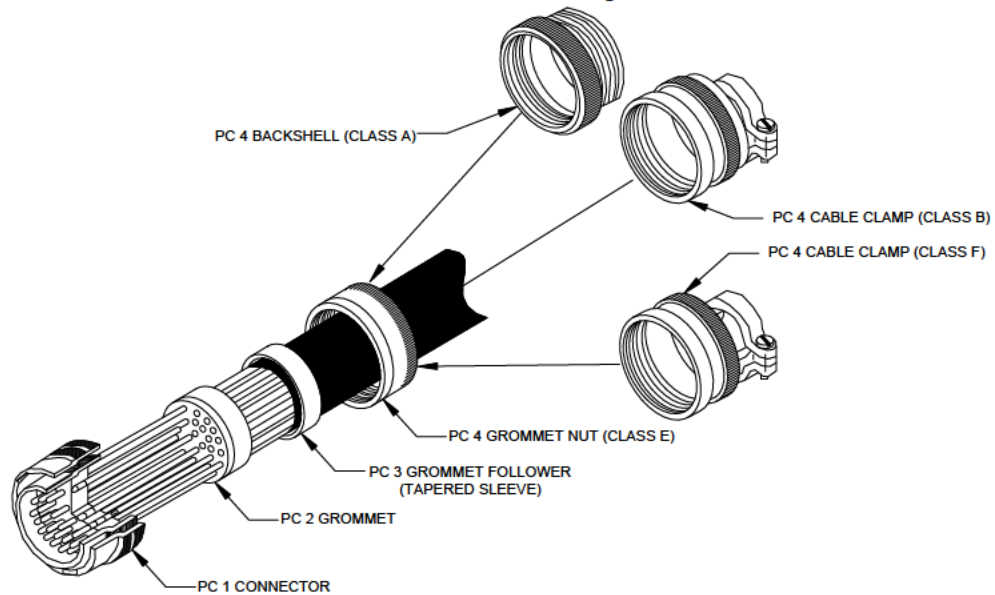

ILLUSTRATION 1
MIL-DTL-26482 TYPICAL CONNECTOR/BACKSHELL CONFIGURATION

FIGURE 5D1. MIL-DTL-26482 connector assembly procedure.

MIL-STD-2003-5B(SH)
APPENDIX 5D

MIL-DTL-26482 connector assembly procedure (continued):

- e. Visually inspect the components for damage such as deformed parts, gouges, damaged threads, cut O-rings, burrs, or surface damage. Visually inspect the grommet for newly installed and for already installed connectors being serviced for cracks and material brittleness that could cause short circuits or electrical or electromagnetic interference in system circuits. If cracks or brittleness are observed, the grommet or the entire connector should be replaced.
 - f. Verify that the series 1 crimp pin contacts conform to SAE-AS39029/31, series 1 crimp socket contacts conform to SAE-AS39029/32, series 2 crimp pin contacts conform to SAE-AS39029/4, or series 2 crimp socket contacts conform to SAE-AS39029/5 and are the correct size and type for the connector being assembled.
 - g. If the conductors are re-twisted during lead preparation, ensure they are twisted as tight as originally constructed, the natural lay of the conductor is maintained, and the conductors will fit inside the contact barrel.
2. Prepare the cable in accordance with [figure 5A1](#). The grommet (PC 2, illustration 1) is designed to fit around individual conductors on classes E and F and therefore cannot be placed on the cable until individual conductors have been exposed in the cable.
 3. Insertion setup: Owing to the many possible variations for acceptable tooling for contact insertion and soldering, no specification is made as to a particular type. The components that are desirable for an acceptable assembly fixture are as follows: A dummy receptacle, without connector insert, to hold the connector being worked on securely or a clamping device that will not damage the connector; a cable clamping fixture to hold the cable in a secure, fixed relationship to the connector while permitting access to the rear face of the connector for the contact insertion tool or soldering iron; a device for holding the wire bundle out of the work area; contact insertion guides for socket contacts to prevent the collapse of adjacent insert holes as the connector is gradually filled with contacts (this facet becomes increasingly important as the contact density increases). A recommended assembly fixture is shown in illustration 2.
NOTE: Equivalent tooling is acceptable; however, the use of other tools may affect the procedural steps outlined below.
 - a. Secure the assembly fixture to a vise or similar holding device in order to provide a stable work area.
 - b. Use of this assembly fixture negates the need for a dummy receptacle. Illustration 3 illustrates how the connector is firmly seated in the connector clamp.
 - c. Seat the connector in the connector clamp and adjust the wing nuts to secure it in place.

FIGURE 5D1. MIL-DTL-26482 connector assembly procedure – Continued.

MIL-STD-2003-5B(SH)
APPENDIX 5D

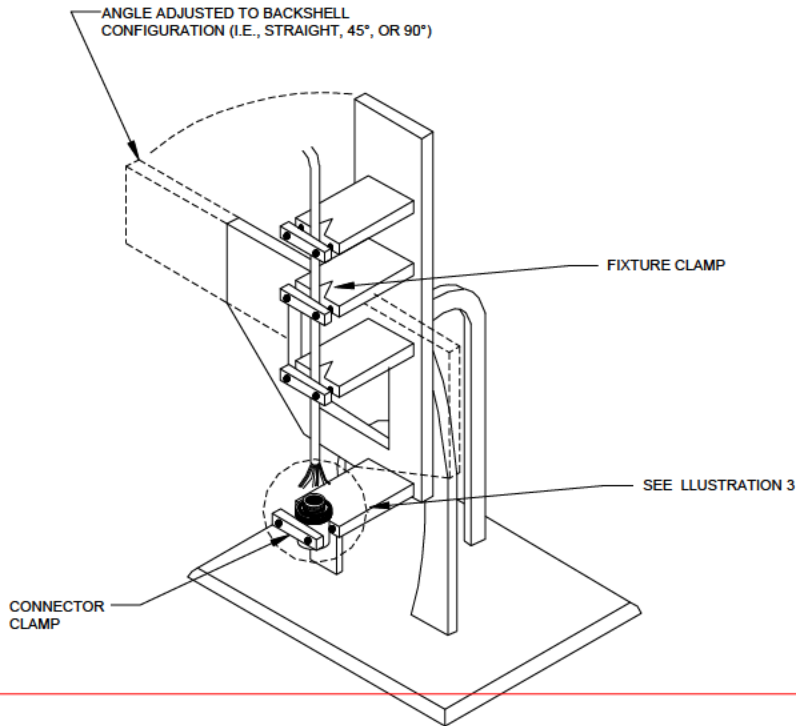

ILLUSTRATION 2
ASSEMBLY FIXTURE

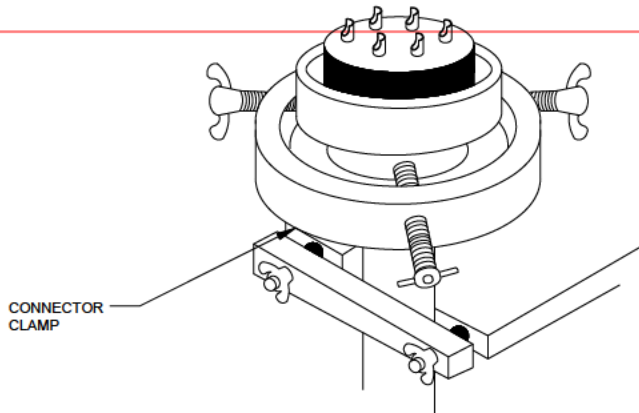
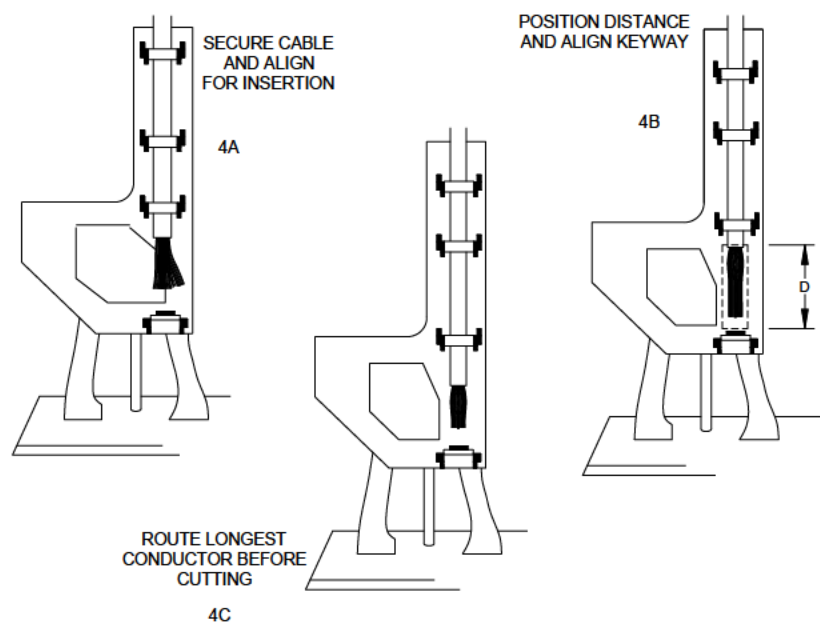

ILLUSTRATION 3
CONNECTOR SEATED IN ASSEMBLY FIXTURE

MIL-DTL-26482 connector assembly procedure (continued):

- d. Place the prepared cable in the fixture clamp so that the first contacts to be inserted/soldered will be at the back of the connector as it is held in the connector clamp.
- e. Position the cable at a position similar to the backshell design (i.e., 45 degrees, 90 degrees, or straight). Secure the cable in the fixture clamp (see illustration 4A).
- f. Position the connector so that the connector-to-cable jacket distance is that measured in step 9.b of [figure 5A1](#). Rotate the connector to align the keyway position in proper relationship to the backshell (see illustration 4B).
- g. Route the individual conductors per the applicable wiring table. Ensure that the longest routed conductor has sufficient length at the required position termination prior to cutting any conductor (see illustration 4C).

FIGURE 5D1. MIL-DTL-26482 connector assembly procedure – Continued.

MIL-STD-2003-5B(SH)
APPENDIX 5DILLUSTRATION 4
DETERMINING CONDUCTOR LENGTH**MIL-DTL-26482 connector assembly procedure (continued):**

- h. Cut the conductors as required to provide even conductor lengths at the connector insert.
NOTE: Leave the spares full length.
4. Strip the individual conductors in accordance with [figure 5A3](#) (for contact wire barrel depths, see [table 5D1-I](#)).

TABLE 5D1-I. Wire barrel depth.

Contact size	Series 1 (inches)			Series 2 (inches)	
	Solder +0.063 -0.016	Crimp		Crimp	
		Socket	Pin	Socket	Pin
20	0.125	0.250–0.270	0.250–0.270	0.157–0.186	0.157–0.186
16	0.188	0.236–0.281	0.236–0.281	0.250–0.284	0.250–0.284
12	0.188	0.236–0.281	0.236–0.281	0.250–0.284	0.250–0.284

5. Terminate the conductors for series 1 connectors as follows:
- Insert conductors into the proper holes of the wire sealing grommet (PC 2, illustration 1). Position the grommet next to the cable jacket.
 - For solder contacts, tin the conductors in accordance with [figure 5A5](#). Ensure conductor strands are twisted tight.
 - For crimp contacts, select the correct crimping tool from [table 5D1-II](#) for series 1 connectors and [table 5D1-III](#) for series 2 connectors.

FIGURE 5D1. MIL-DTL-26482 connector assembly procedure – Continued.

MIL-STD-2003-5B(SH)
APPENDIX 5D

TABLE 5D1-II. Crimping tools for series 1 connectors.

Contact size	Pin contact		Socket contact	
	Crimping tool	Positioner	Crimping tool	Positioner
20	M22520/7-01	M22520/7-02	M22520/7-01	M22520/7-02
	M22520/1-01	M22520/1-02 red	M22520/1-01	M22520/1-02
	M22520/2-01	M22520/2-02	M22520/2-01	M22520/2-02
16	M22520/1-01	M220520/1-02 blue	M22520/1-01	M22520/1-02 blue
	M22520/7-01	M22520/7-03	M22520/7-01	M22520/7-03
12	M22520/1-01	M22520/1-02 yellow	M22520/1-01	M22520/1-02 yellow

TABLE 5D1-III. Crimping tools for series 2 connectors.

Contact size	Pin contact		Socket contact	
	Crimping tool	Positioner	Crimping tool	Positioner
20	M22520/1-01	M22520/1-02 red	M22520/2-01	M22520/2-02
	M22520/2-01	M22520/2-02	M22520/1-01	M22520/1-02 red
16	M22520/1-01	M22520/1-02 blue	M22520/1-01	M22520/1-02 blue
	M22520/7-01	M22520/7-03	M22520/7-01	M22520/7-03
12	M22520/1-01	M22520/1-02 yellow	M22520/1-01	M22520/1-02 yellow

MIL-DTL-26482 connector assembly procedure (continued):

- d. Terminate individual conductors with crimp contacts in accordance with [figure 5A4](#). If contact rework shortens a conductor's initial length by greater than ¼ inch, the jacket shall be cut back again and all conductors re-trimmed to preclude stress.
6. Conductor/contact insertion into connector:
NOTE: Upon insertion of each two rows of pin contacts, visually inspect the connector face to ensure that the contacts are properly inserted.
 - a. Insert series 1 connectors as follows:
 - (1) Accomplish the following for solder contacts:
WARNING: Do not move the conductor after the soldering iron has been removed or a cold soldered joint could result.
 - (a) Solder the conductors to the contacts in accordance with [figure 5A6](#). Soldering should commence with the contact row(s) furthest away from the operator. A piece of stiff fire-retardant paper should be inserted between the rows as the rows are completed to aid in protecting completed work (see illustration 5).

FIGURE 5D1. MIL-DTL-26482 connector assembly procedure – Continued.

MIL-STD-2003-5B(SH)
APPENDIX 5D

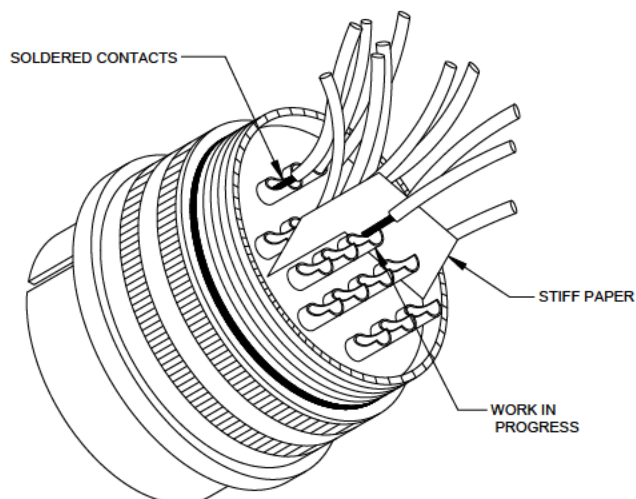

ILLUSTRATION 5
PROTECTING SOLDERED CONTACTS

MIL-DTL-26482 connector assembly procedure (continued):

- (2) Accomplish the following for crimp contacts:

NOTE: Adjust the assembly fixture as required during the insertion process to ease stress on the conductors.

- (a) Select the proper insertion tool from [table 5D1-IV](#).

TABLE 5D1-IV. Insertion and removal tools.

Contact size	Pin contact		Socket contact	
	Insertion tool	Removal tool	Insertion tool	Removal tool
20	MS81969/17-03	MS81969/19-07	MS84969/17-03	MS81969/19-07
	MS84969/14-02		MS84969/14-02	
16	MS81969/17-04	MS81969/19-08	MS84969/14-03	MS81969/19-08
	MS81969/14-03		MS84969/17-04	
12	MS81969/17-05	MS81969/19-09	MS84969/14-04	MS81969/19-09
	MS84969/14-04		MS84969/17-05	

- (b) Insert a wired contact into the rear of the insert.
(c) Seat the contact by positioning the insertion tool around the rear of the contact shoulder with a slight angle toward the contact to assure a firm grip (see illustration 6).

FIGURE 5D1. MIL-DTL-26482 connector assembly procedure – Continued.

MIL-STD-2003-5B(SH)
APPENDIX 5D

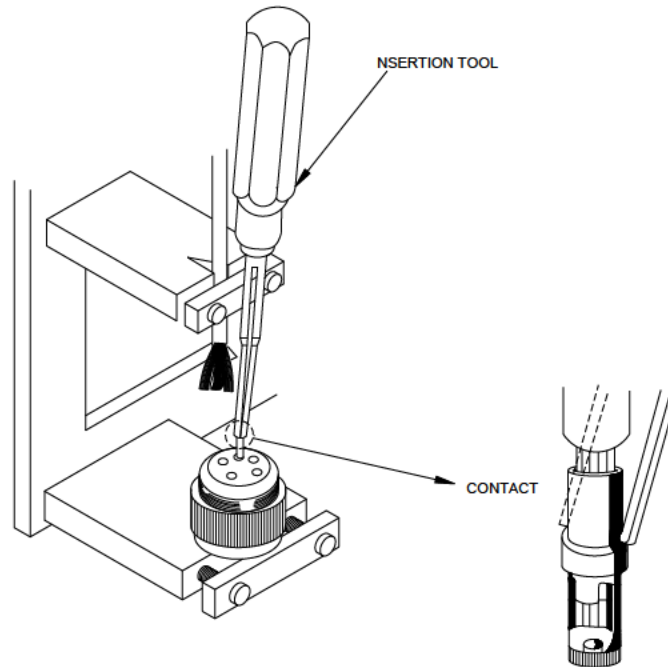

ILLUSTRATION 6
CONTACT INSERTION (SERIES 1)

MIL-DTL-26482 connector assembly procedure (continued):

- 1 Push the contact straight into the connector with a firm, steady pressure until the contact bottoms.
 - 2 The contact shoulder provides a positive stop.
- (d) Move the insertion tool back away from the contact before sliding it straight up along the wire insulation until it clears the insert. Slightly pull on inserted lead to ensure contact has locked in connector.
- b. Accomplish the following steps for series 2 connectors:
NOTE: Adjust the assembly fixture as required during the insertion process to ease stress on the conductors.
- (1) Select the proper insertion tool from [table 5D1-V](#).

FIGURE 5D1. MIL-DTL-26482 connector assembly procedure – Continued.

MIL-STD-2003-5B(SH)
APPENDIX 5D

TABLE 5D1-V. Insertion and removal tools.

Socket contact			
Contact size	Insertion tool	Removal tool	
		Wired contact	Unwired contact
20	M81969/8-05	M81969/8-06	M81969/30-05
	M81969/14-02	M81969/14-02	
16	M81969/8-07	M81969/8-08	M81969/30-06
	M81969/14-03	M81969/14-03	
12	M81969/8-09	M81969/8-10	M81969/30-07
	M81969/14-04	M81969/14-04	
Socket contact			
Contact size	Insertion tool	Removal tool	
		Wired contact	Unwired contact
20	M81969/14-02	M81969/14-02	M81969/30-05
16	M81969/14-03	M81969/14-03	M81969/30-06
12	M81969/14-04	M81969/14-04	M81969/30-07

MIL-DTL-26482 connector assembly procedure (continued):

- (2) Lay the wire, with contact attached, against the slot of the correct insertion tool and snap into the tool (see illustration 7).
- (3) Seat the contact shoulder against the tip of the tool.
- (4) Push the contact into the proper opening at the rear of the insert by applying straight, steady, forward pressure until the contact bottoms.
NOTE: Do not twist the tool.
- (5) Remove the tool by sliding it straight back along the wire. Unsnap the tool from the wire when clear of the insert.

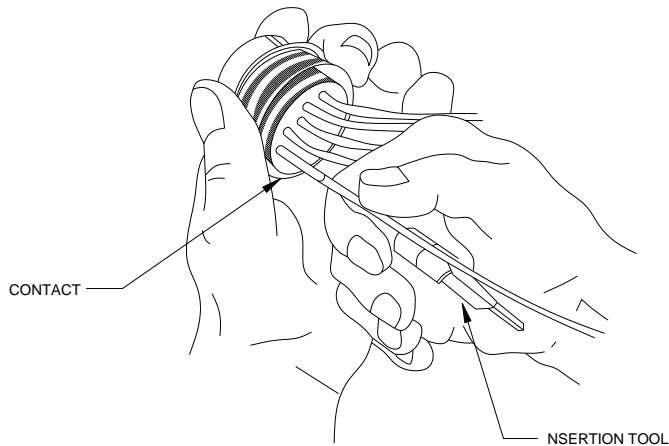
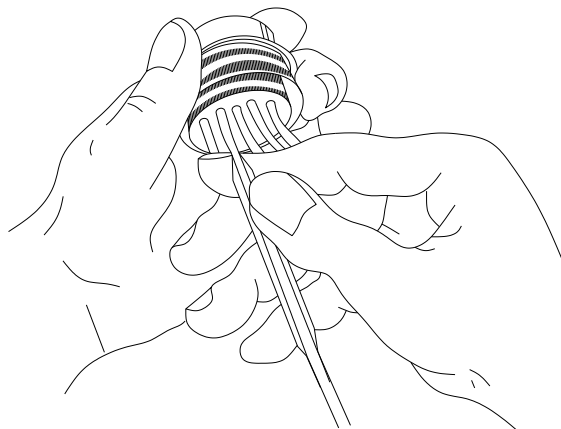

ILLUSTRATION 7
CONTACT INSERTION (SERIES 2)

FIGURE 5D1. MIL-DTL-26482 connector assembly procedure – Continued.

MIL-STD-2003-5B(SH)
APPENDIX 5DILLUSTRATION 7 (CONTINUED)
CONTACT INSERTION (SERIES 2)**MIL-DTL-26482 connector assembly procedure (continued):**

- (a) Slightly pull on inserted conductor to ensure contact has locked in connector.
 - c. Ensure that the shield ground wire (if terminated to a contact) is inserted in its proper location.
 - d. Insert unwired contacts into all empty holes in the connector insert.
 - e. Insert sealing plugs meeting the requirements of MS27488 into all unwired contact holes for series 1, classes E and F, and all environmental series 2, connectors. Sealing plugs are required for environmental connectors, but not for non-environmental connectors.
 - f. Remove the connector from the connector clamp.
 - g. Conduct a visual check of the connector and verify wire location against the wiring table. Ensure no debris is inside socket contacts.
7. Contact removal procedures (as required):
- a. Conduct a visual inspection of the connector face to identify any unseated contacts.
 - b. If required to remove unseated contacts, proceed as follows:
 - (1) Remove unseated series 1 crimp contacts as follows:
 - (a) Select the proper removal tool from [table 5D1-IV](#).

FIGURE 5D1. MIL-DTL-26482 connector assembly procedure – Continued.

MIL-STD-2003-5B(SH)
APPENDIX 5D

MIL-DTL-26482 connector assembly procedure (continued):

- (b) Insert the removal tool into the connector face, placing the sleeve of the tool over the contact to be removed.
 - (c) Using straight, forward motion, push and slightly rotate the tool until the sleeve bottoms in the insert.
 - (d) Push the removal tool thrust collar forward, which moves the contact back through the insert, exposing it for easy hand removal.
 - (e) Remove the removal tool from the connector.
 - (2) Remove unseated series 2 contacts as follows:
 - (a) Select the correct removal tool from [table 5D1-V](#).
 - (b) Lay the slot of the tool against the wire of the contact to be removed leaving ½ inch from the tool end to the rear of the connector.
 - (c) Squeeze the wire firmly into the tool between the thumb and forefinger about ½ inch from the tool tip.
 - (d) Slide the tool down along the wire and slowly into the insert until positive resistance is felt.
WARNING: Do not twist or turn the tool.
 - (e) Pull both the tool and wired contact out of the connector.
 - c. Reinsert all extracted contacts.
 - d. If a contact fails to reseat after three insertion attempts, replace the offending contact. If the same contact location continues to give difficulty, the connector is probably damaged or faulty and should be replaced.
8. Backshell assembly:
- NOTE: The following assembly procedure is based on the nomenclature and hardware configuration depicted in illustration 1. Variations may occur and cause minor deviations from this procedure. If this situation occurs, the manufacturer's assembly instructions should be followed.
- a. Fold the spare wires back one-half the distance between the connector and the jacket end.
 - b. Slide a 1-inch long piece of ¼-inch shrink tubing over each folded pair and shrink in place.
 - c. Lightly coat the threads of each backshell part with petroleum jelly just prior to using.
 - d. Loosen the fixture clamp from the assembly fixture.
 - e. For class "A" connectors:
 - (1) Slide the backshell over the conductors and tighten appropriately (see 4.5).
 - f. For class "E" and "F" connectors:
 - (1) Slide the grommet (PC 2, illustration 1) over the wire bundle.
 - (2) Slide the tapered sleeve (PC 3, illustration 1) and grommet nut (PC 4, illustration 1) over the grommet and tighten the grommet nut (see 4.5).
 - (a) Ensure the tapered sleeve is not cocked in the nut.

FIGURE 5D1. [MIL-DTL-26482 connector assembly procedure](#) – Continued.

MIL-STD-2003-5B(SH)
APPENDIX 5D

MIL-DTL-26482 connector assembly procedure (continued):

- g. If a cable clamp is attached (class “B” or “F”), attach the clamp to the connector assembly and tighten appropriately (see 4.5).
- h. Alternately tighten the clamping bar screws until the clamping bar is properly seated with a minimum gap of not less than $\frac{1}{16}$ inch between the clamp support and clamp saddle (see illustration 8) (see 4.5).
NOTE: If required, install personnel safety ground under clamping bar screw.

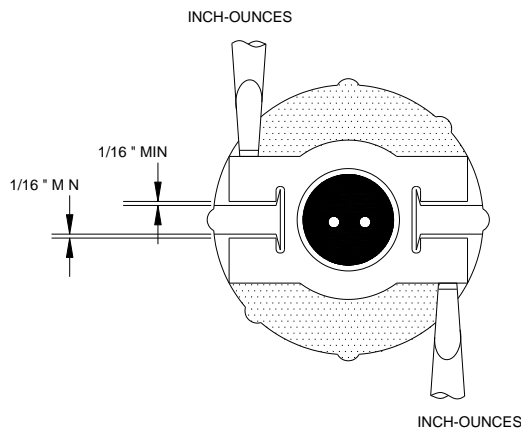

ILLUSTRATION 8
CLAMP SCREW GAP

- i. Remove the connector from the assembly fixture.
9. Final test and documentation:
 - a. Perform electrical/electronic checks on the assembled connector (see 4.5).
 - b. Install a protective dust cap on the connector.
 - c. Complete the assembly inspection and documentation as required by local procedures.
 10. If necessary, lockwire the connector in accordance with [figure 5A9](#).

FIGURE 5D1. MIL-DTL-26482 connector assembly procedure – Continued.

MIL-STD-2003-5B(SH)
APPENDIX 5E

APPENDIX 5E – MIL-DTL-28840 CONNECTORS

E.1 SCOPE

E.1.1 Scope. This appendix provides instructions for preparing cable in preparation for MIL-DTL-28840 connectors and assembly of such connectors. This appendix is a mandatory part of the standard. The information contained herein is intended for compliance.

E.2 APPLICABLE DOCUMENTS

E.2.1 General. The documents listed in this section are specified in this appendix. This section does not include documents cited in other sections of this standard or recommended for additional information or as examples. While every effort has been made to ensure the completeness of this list, document users are cautioned that they must meet all specified requirements of documents cited in this appendix, whether or not they are listed.

E.2.2 Government documents.

E.2.2.1 Specifications, standards, and handbooks. The following specifications, standards, and handbooks form a part of this document to the extent specified herein. Unless otherwise specified, the issues of these documents are those cited in the solicitation or contract.

DEPARTMENT OF DEFENSE SPECIFICATIONS

- | | | |
|------------------|---|--|
| MIL-DTL-28840 | - | Connectors, Electrical, Circular, Threaded, High Shock, High Density, Shipboard, Class D, General Specification for |
| MIL-DTL-28840/10 | - | Connectors, Electrical, Circular, Threaded, High Shock, High Density, Shipboard, Crimp Contacts, Receptacle, Wall Mounting, Classes D, DS, P, T, and Z |
| MIL-DTL-28840/12 | - | Connectors, Electrical, Circular, Threaded, High Shock, High Density, Shipboard, Crimp Contacts, Receptacle, Box Mounting, Classes D, DS, P, T, and Z |
| MIL-DTL-28840/16 | - | Connectors, Electrical, Circular, Threaded, High Shock, High Density, Shipboard, Crimp Contacts, Plug, Classes D, DS, P, T, and Z |
| MIL-DTL-28840/18 | - | Connectors, Electrical, Circular, Threaded, High Shock, High Density, Shipboard, Crimp Contacts, Plug Assembly, Open Wire, 90°, Classes D, DS, P, T, and Z |
| MIL-DTL-28840/26 | - | Connectors, Electrical, Circular, Threaded, High Density, High Shock, Shipboard, Crimp Contacts, Plug Assembly, Straight, Classes DJ, DJS, PJ, TJ, and ZJ |
| MIL-DTL-28840/28 | - | Connectors, Electrical, Circular, Threaded, High Density, High Shock, Shipboard, Crimp Contacts, Plug Assembly, 90°, Classes DJ, DJS, PJ, TJ, and ZJ |
| MIL-DTL-28840/29 | - | Connectors, Electrical, Circular, Threaded, High Shock, High Density, Shipboard, Crimp Contacts, Plug Assembly, 45°, Classes DJ, DJS, PJ, TJ, and ZJ |

(Copies of these documents are available online at <https://quicksearch.dla.mil/>.)

E.2.2.2 Other Government documents, drawings, and publications. The following other Government documents, drawings, and publications form a part of this document to the extent specified herein. Unless otherwise specified, the issues of these documents are those cited in the solicitation or contract.

MIL-STD-2003-5B(SH)
APPENDIX 5E

MILITARY SPECIFICATION SHEETS

MS27488 - Plug, End Seal, Electrical Connector

(Copies of this document are available online at <https://quicksearch.dla.mil>.)

E.2.3 Non-Government publications. The following documents form a part of this document to the extent specified herein. Unless otherwise specified, the issues of these documents are those cited in the solicitation or contract.

SAE INTERNATIONAL

- SAE-AS31971 - Gage Pin for Socket Contact Engagement Test
- SAE-AS39029/83 - Contacts, Electrical Connector, Pin, Crimp Removable (for MIL-DTL-28840 Connectors)
- SAE-AS39029/84 - Contacts, Electrical Connector, Socket, Crimp Removable (for MIL-DTL-28840 Connectors)

(Copies of these documents are available online at www.sae.org.)

E.2.4 Order of precedence. Unless otherwise noted herein or in the contract, in the event of a conflict between the text of this document and the references cited herein, the text of this document takes precedence. Nothing in this document, however, supersedes applicable laws and regulations unless a specific exemption has been obtained.

E.3 REQUIRED EQUIPMENT AND MATERIALS

E.3.1 Required equipment and materials. The required equipment and materials are specified in the standard methods of this section.

E.4 NOTES AND PROCEDURES

E.4.1 Dimensions. For figures and tables in this appendix, all dimensions are in inches unless otherwise noted.

E.4.2 Figures. [Table 5E1](#) provides information for the figures in this appendix.

TABLE 5E1. Figures for MIL-DTL-28840 connector assembly preparation.

Figure number	MIL-DTL-28840 connector assembly procedures	Page
5E1	MIL-DTL-28840 connector assembly procedure	158

MIL-STD-2003-5B(SH)
APPENDIX 5E

MIL-DTL-28840 connector assembly procedure:

Applicable connectors: The procedures in this appendix specifically cover assembly of connectors in accordance with the following specification sheets and subordinate specifications of MIL-DTL-28840. This appendix may also be used to assemble connectors in accordance with other specification sheets and subordinate specifications of MIL-DTL-28840. Installation of other connectors covered in specifications subordinate to the main specification in this appendix shall use the installation requirements in this appendix to the maximum extent practicable.

MIL-DTL-28840/10
MIL-DTL-28840/12
MIL-DTL-28840/16
MIL-DTL-28840/18
MIL-DTL-28840/26
MIL-DTL-28840/28
MIL-DTL-28840/29

1. Visual inspection and verification:

- a. Disassemble the connector/backshell assembly.
- b. Verify that the connector is of the correct type and configuration for the cable being terminated in accordance with the system cabling diagram.
- c. Verify that the backshell configuration is of the correct type as specified on the system cabling diagram.
- d. Verify that all component parts of the connector and backshell hardware are present. (See illustration 1 for a typical connector/backshell configuration.) Refer to MIL-DTL-28840 for specific configurations.

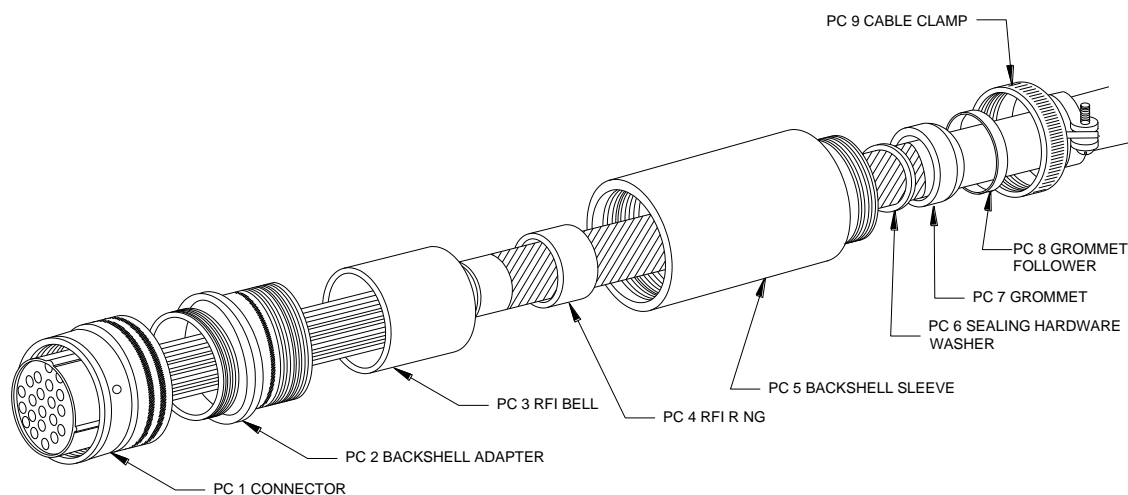

ILLUSTRATION 1
TYPICAL CONNECTOR/BACKSHELL CONFIGURATION

- e. Visually inspect the components for damage such as deformed parts, gouges, damaged threads, cut O-rings, burrs, or surface damage.
 - f. Verify that the contacts meet the requirements of SAE-AS39029/83 for pin and SAE-AS39029/84 for socket contacts.
 - g. If the conductors are re-twisted during lead preparation, ensure they are twisted as tight as originally constructed, the natural lay of the conductor is maintained, and the conductors will fit inside the contact barrel.
2. Cable preparation: Prepare the cable in accordance with [figure 5A1](#).

FIGURE 5E1. MIL-DTL-28840 connector assembly procedure.

MIL-STD-2003-5B(SH)
APPENDIX 5E

MIL-DTL-28840 connector assembly procedure (continued):

3. Insertion setup: Owing to the many possible variations for acceptable designs for an assembly fixture, no specification is made as to a particular type. The components, that are desirable for an acceptable assembly fixture, are as follows: A dummy receptacle, without connector insert, to hold the connector being worked on securely or a clamping device that will not damage the connector; a cable clamping fixture (see illustration 2) to hold the cable in a secure fixed relationship to the connector while permitting access to the rear face of the connector for the contact insertion tool; a device for holding the wire bundle out of the work area. The assembly fixture recommended is shown in illustration 2.

NOTE: Equivalent tooling is acceptable; however, the use of other tools may affect the procedural steps outlined below.

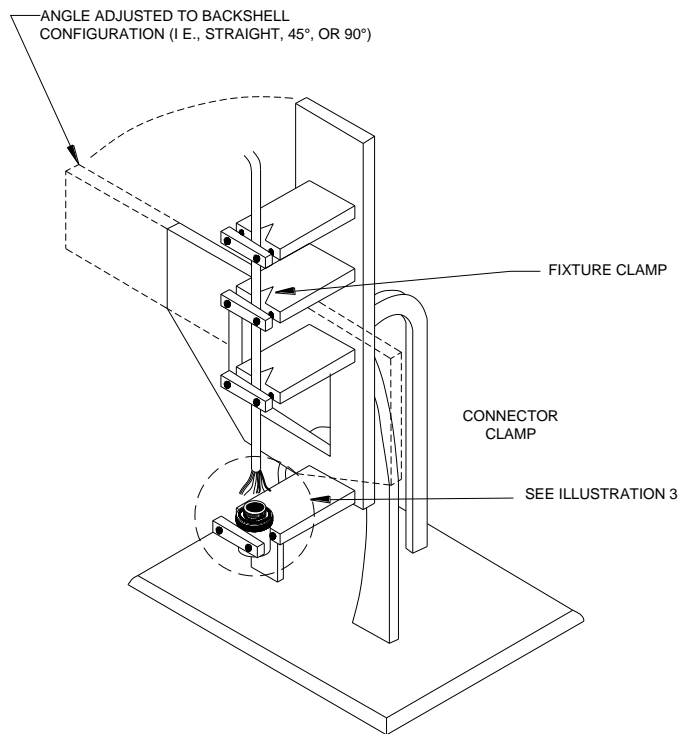
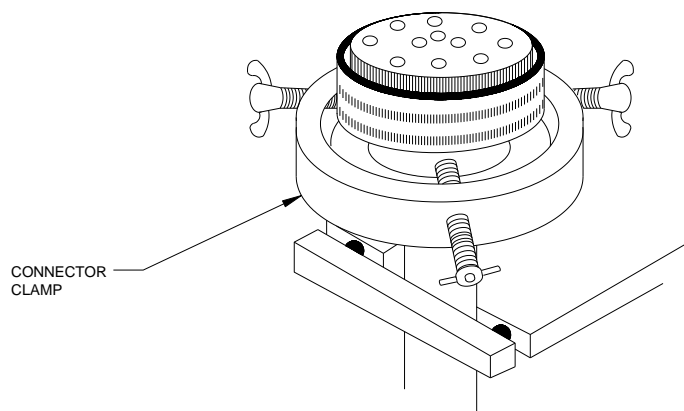

ILLUSTRATION 2
ASSEMBLY FIXTURE

FIGURE 5E1. MIL-DTL-28840 connector assembly procedure – Continued.

MIL-STD-2003-5B(SH)
APPENDIX 5EILLUSTRATION 3
CONNECTOR SEATED IN ASSEMBLY FIXTURE**MIL-DTL-28840 connector assembly procedure (continued):**

- a. Secure the assembly fixture to a vise or similar holding device in order to provide a stable work area.
- b. Use of this assembly fixture negates the need for a dummy receptacle. Illustration 3 illustrates how the connector is firmly seated in the connector clamp.
- c. Seat the connector in the connector clamp and adjust the wing nuts to secure it in place.
- d. Place the prepared cable in the fixture clamp so that the first contacts to be inserted will be at the back of the connector as it is held in the connector clamp.
- e. Position the cable at the angle similar to the backshell design (i.e., 45 degrees, 90 degrees, or straight). Secure the cable in the fixture clamp (see illustration 4A).
- f. Position the connector so that the connector-to-cable jacket distance is that measured in step 9.b of [figure 5A1](#). Rotate the connector to align the keyway position in proper relationship to the backshell (see illustration 4B).
- g. Route the individual conductors in accordance with the applicable wiring table. Ensure that the longest routed conductor has sufficient length at the required position termination prior to cutting any conductor (see illustration 4C).

FIGURE 5E1. MIL-DTL-28840 connector assembly procedure – Continued.

MIL-STD-2003-5B(SH)
APPENDIX 5E

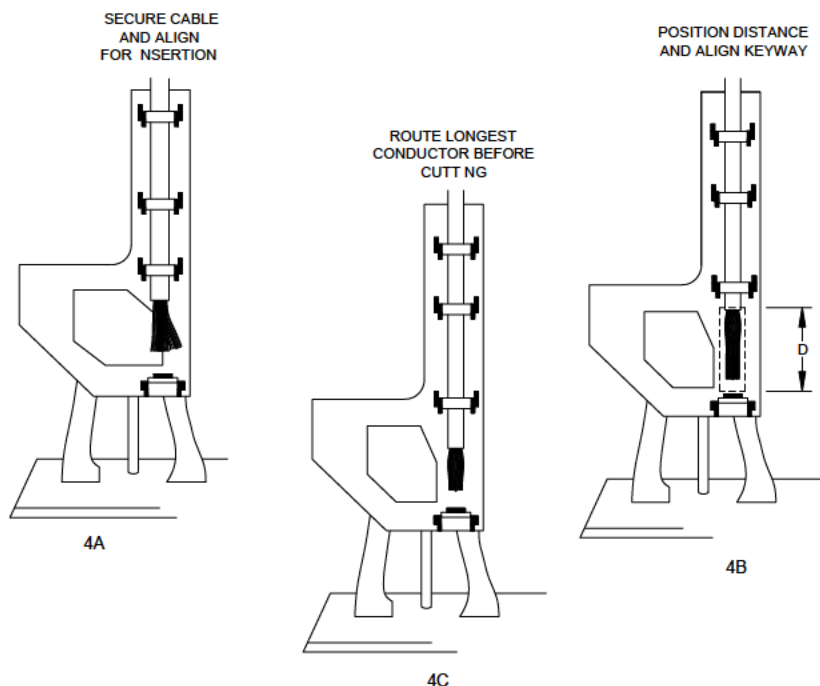

ILLUSTRATION 4
DETERMINING CONDUCTOR LENGTH

MIL-DTL-28840 connector assembly procedure (continued):

- h. Cut the conductors as required to provide even conductor lengths at the connector insert.
NOTE: Leave the spares full length.
4. Strip the individual conductors in accordance with [figure 5A3](#) (contact wire barrel depth is 0.160-0.208 inch).
5. Prior to crimping, a contact-sizing test should be accomplished for all socket contacts. (Pin contacts previously verified in step 1 f do not need further testing.) Socket contacts should be inspected for proper size using a pin contact gauge conforming to SAE-AS31971.
6. Terminate individual conductors with crimp contacts in accordance with [figure 5A4](#). (Ensure the crimping tool conforms to M22520/34-01 with positioner M22520/34-02.) If contact rework shortens a conductor's initial length by greater than ¼ inch, the jacket shall be cut back again.
7. Using the proper wiring table, and working from the rear to the front of the assembly fixture, insert the contacts into their designated locations as follows (see illustration 5):
NOTE: Adjust the fixture clamp as required during the insertion process to ease stress on the conductors.

FIGURE 5E1. MIL-DTL-28840 connector assembly procedure – Continued.

MIL-STD-2003-5B(SH)
APPENDIX 5E

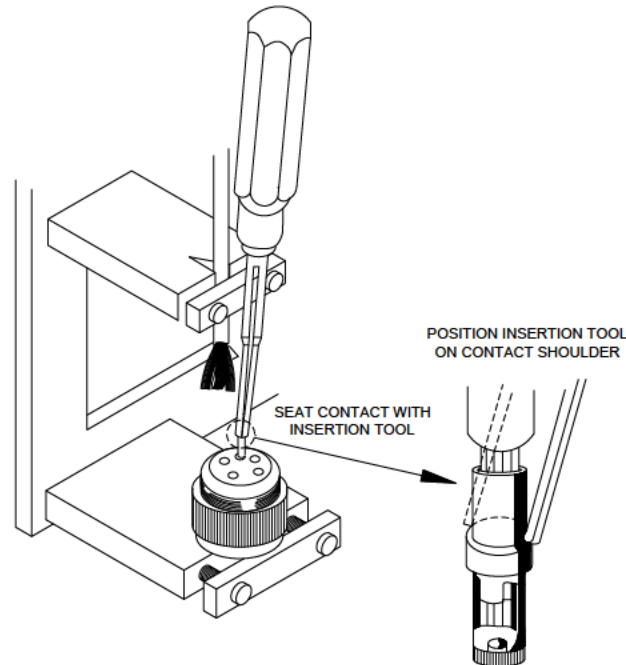

ILLUSTRATION 5
CONTACT INSERTION

MIL-DTL-28840 connector assembly procedure (continued):

- a. Ensure the insertion tool conforms to M81969/33-01.
 - b. Insert a wired contact into the rear of the insert.
 - c. Push the contact forward until the shoulder of the contact is slightly exposed behind the insert.
 - d. Seat the contact by positioning the insertion tool around the rear of the contact shoulder with a slight angle toward the contact to assure a firm grip.
 - (1) Push the contact straight into the connector with a firm steady pressure until the contact bottoms.
 - (2) The contact shoulder provides a positive stop.
NOTE: Upon insertion of each two rows of contacts, visually inspect the connector face to ensure that the contacts are properly inserted and do not “cross over” into adjacent holes. Any improperly inserted contacts will appear angled when compared to the properly inserted contacts.
 - (3) Move the insertion tool back away from the contact before sliding it straight up along the wire insulation until it clears the insert.
 - (4) Lightly pull on the inserted lead to ensure the contact has locked in the connector.
 - e. Ensure that the shield ground wire (if terminated to a contact) is inserted in its proper location.
8. Insert unwired contacts into all empty holes in the connector insert.
 9. Insert sealing plugs that meet the requirements of MS27488, into all unwired contact holes. Sealing plugs are required for environmental connectors, but not for non-environmental connectors.
 10. Conduct a final visual check of the connector and verify wire location against the wiring table by means of a continuity test. Ensure no debris is inside socket contacts.
 11. Contact removal procedure (as required):
 - a. Conduct a visual inspection of the connector to identify any unseated contacts.
 - b. If required, remove the connector from the connector clamp, and using the proper extraction tool (M81969/34-01), remove the unseated contact as follows (see illustration 6):

FIGURE 5E1. MIL-DTL-28840 connector assembly procedure – Continued.

MIL-STD-2003-5B(SH)
APPENDIX 5E

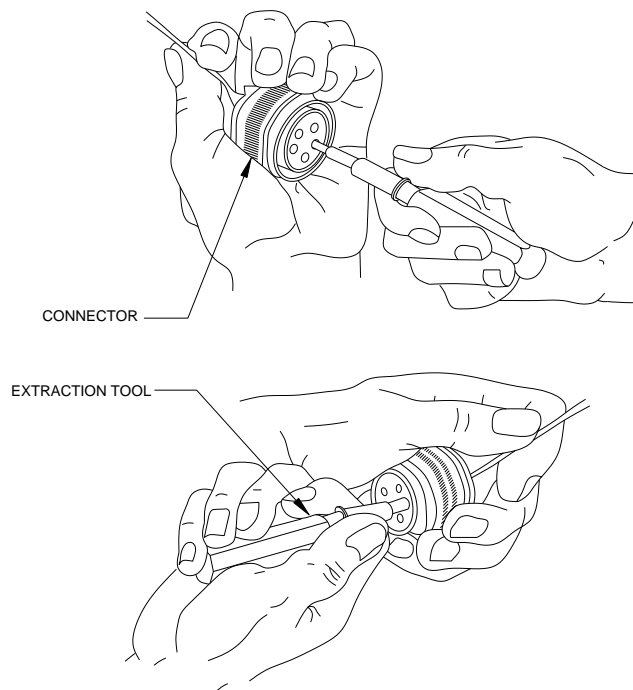

ILLUSTRATION 6
REMOVING A CONTACT

MIL-DTL-28840 connector assembly procedure (continued):

- (1) Insert the extraction tool into the connector face and enclose the front of the contact with the tool.
 - (2) Pushing with the rear of the tool to fully bottom the tool tip, rotate the tool rear slightly in the clockwise direction.
 - (3) Push the tool thrust sleeve forward moving the contact back through the insert.
 - (4) Remove the contact from the rear of the connector and slowly remove the extraction tool from the face of the contact.
- c. Reinsert all extracted contacts in accordance with step 7 and re-inspect the connector face.
 - d. If a contact fails to reseat after three insertion attempts, replace the offending contact. If the same contact location continues to give difficulty, the connector is probably damaged or faulty and should be replaced.
 - e. Remove the connector from the connector clamp if not previously accomplished.
12. Backshell assembly:
- NOTE: The following assembly procedure is based on the nomenclature and hardware configuration depicted in illustration 1. Variations may occur and cause minor deviations from this procedure. If this situation occurs, the manufacturer's assembly instructions should be followed.
- a. Fold spare wires back one-half the distance between the connector and the jacket end.
 - b. Slide a 1-inch long piece of appropriately sized shrink tubing over each folded pair and shrink in place.
 - c. Lightly coat the thread of each backshell part with petroleum jelly just prior to using.
 - d. Position and lubricate all O-rings.
 - e. Loosen the cable clamp on the assembly fixture.
 - f. Slide the backshell adapter (PC 2, illustration 1) down the cable and screw it on the connector. Tighten the adapter appropriately (see 4.5).

FIGURE 5E1. MIL-DTL-28840 connector assembly procedure – Continued.

MIL-STD-2003-5B(SH)
APPENDIX 5E

MIL-DTL-28840 connector assembly procedure (continued):

- g. If the gross shield is to be floated or terminated to a connector contact, proceed to step 12 h. If the shield is to be terminated to the backshell RFI hardware, proceed as follows:
 - (1) Slide the RFI bell (PC 3, illustration 1) against the backshell adapter.
 - (2) Flare the gross shield over the tapered end of the RFI bell.
 - (3) Gently force the cable toward the connector plug until the shield covers the tapered surface on the RFI bell.
 - (4) Slide the RFI ring (PC 4, illustration 1) onto the RFI bell while applying forward pressure on the cable.
 - (5) Compress the shield between the RFI bell and RFI ring with a back and forth twisting forward motion on the RFI ring.
- h. Slide the RFI backshell components (PC 3 and 4, illustration 1) over the pigtails, looped ground wire, and spare conductors.
- i. Slide the backshell sleeve (PC 5, illustration 1) over the RFI assembly and screw the sleeve onto the adapter.
- j. Tighten the sleeve appropriately (see 4.5).
- k. Mark a line on the cable $\frac{1}{4}$ inch- $\frac{1}{2}$ inch above the backshell sleeve (see illustration 7). Carefully push the cable into the backshell $\frac{1}{4}$ inch- $\frac{1}{2}$ inch and maintain continuous pressure to hold at this position for the next four steps. (Line marked on jacket is parallel with end of backshell sleeve.)

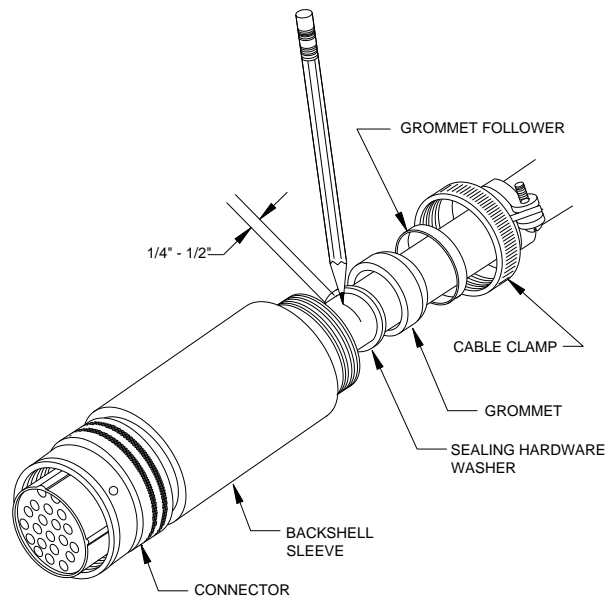

ILLUSTRATION 7
MARKING THE CABLE

- l. Verify the cable jacket is positioned completely through the grommet.
- m. Slide the sealing hardware washer (PC 6, illustration 1), grommet (PC 7, illustration 1), and grommet follower (PC 8, illustration 1) into position behind the sleeve.
- n. Screw the cable clamp (PC 9, illustration 1) onto the sleeve and tighten appropriately (see 4.5).
- o. Alternately tighten (see 4.5) the clamping bar screws until the appropriate gap is achieved (see illustration 8).

NOTE: If required, install personnel safety ground under clamping bar screw.

FIGURE 5E1. MIL-DTL-28840 connector assembly procedure – Continued.

MIL-STD-2003-5B(SH)
APPENDIX 5E

NOTE: Tighten so that a minimum gap of not less than $\frac{1}{16}$ inch is maintained between the clamp support and clamp saddles.

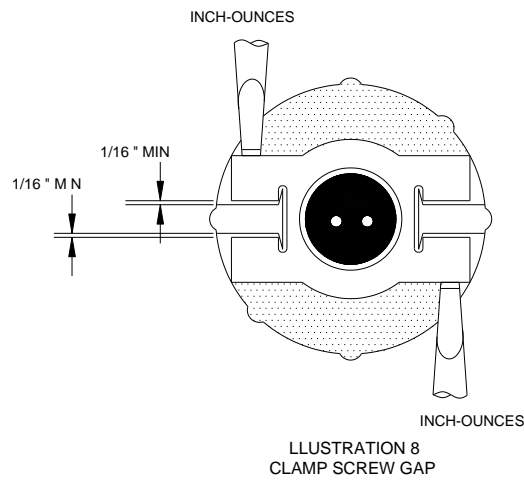

MIL-DTL-28840 connector assembly procedure (continued):

- p. Remove the connector from the assembly fixture.
- 13. Final test and documentation:
 - a. Perform electrical/electronic checks on the assembled connector (see 4.5).
 - b. Install a protective dust cap on the connector.
 - c. Complete the assembly inspection and documentation as required by local procedures.
- 14. If necessary, lockwire the connector in accordance with [figure 5A9](#).

FIGURE 5E1. MIL-DTL-28840 connector assembly procedure – Continued.

MIL-STD-2003-5B(SH)
APPENDIX 5F

APPENDIX 5F – MIL-DTL-27599 CONNECTORS

F.1 SCOPE

F.1.1 Scope. This appendix provides instruction for preparing cable in preparation for MIL-DTL-27599 connectors and assembly of such connectors (see 4.6). This appendix is a mandatory part of the standard. The information contained herein is intended for compliance.

F.2 APPLICABLE DOCUMENTS

F.2.1 General. The documents listed in this section are specified in this appendix. This section does not include documents cited in other sections of this standard or recommended for additional information or as examples. While every effort has been made to ensure the completeness of this list, document users are cautioned that they must meet all specified requirements of documents cited in this appendix, whether or not they are listed.

F.2.2 Government documents.

F.2.2.1 Specifications, standards, and handbooks. The following specifications, standards, and handbooks form a part of this document to the extent specified herein. Unless otherwise specified, the issues of these documents are those cited in the solicitation or contract.

DEPARTMENT OF DEFENSE SPECIFICATIONS

MIL-DTL-27599 - Connectors, Electrical, Circular, Miniature, High Density, Quick Disconnect, Environment Resistant, Solder Contacts, General Specification for (see 4.6)

(Copies of this document are available online at <https://quicksearch.dla.mil/>.)

F.2.2.2 Other Government documents, drawings, and publications. The following other Government documents, drawings, and publications form a part of this document to the extent specified herein. Unless otherwise specified, the issues of these documents are those cited in the solicitation or contract.

MILITARY SPECIFICATION SHEETS

MS20027 - Connectors, Line Plug, Electrical, Solder Type, Bayonet Coupling, Class T, Series I (see 4.6)

MS20028 - Connectors, Plug, Electrical, Straight, Solder Type, Bayonet Coupling, Class T, Series I (see 4.6)

MS27336 - Connectors, Plug, Electrical, Straight, Solder Type, Bayonet Coupling, Classes P and T, Series II (see 4.6)

(Copies of these documents are available online at <https://quicksearch.dla.mil/>.)

F.2.3 Non-Government publications. The following documents form a part of this document to the extent specified herein. Unless otherwise specified, the issues of these documents are those cited in the solicitation or contract.

SAE INTERNATIONAL

SAE-AS85049 - Connector Accessories, Electrical General Specification for

(Copies of this document are available online at www.sae.org.)

F.2.4 Order of precedence. Unless otherwise noted herein or in the contract, in the event of a conflict between the text of this document and the references cited herein, the text of this document takes precedence. Nothing in this document, however, supersedes applicable laws and regulations unless a specific exemption has been obtained.

MIL-STD-2003-5B(SH)
APPENDIX 5F

F.3 REQUIRED EQUIPMENT AND MATERIALS

F.3.1 Required equipment and materials. The required equipment and materials are specified in the standard methods of this section.

F.4 NOTES AND PROCEDURES

F.4.1 Dimensions. For figures and tables in this appendix, all dimensions are in inches unless otherwise noted.

F.4.2 Figures. [Table 5FI](#) provides information for the figures in this appendix.

TABLE 5FI. Figures for MIL-DTL-27599 connector assembly procedures.

Figure Number	MIL-DTL-27599 Connector Assembly Procedures	Page
5F1	MIL-DTL-27599 connector assembly procedure	168

MIL-STD-2003-5B(SH)
APPENDIX 5F

MIL-DTL-27599 connector assembly procedure:

Applicable connectors: The procedures in this appendix specifically cover assembly of connectors in accordance with the following specification sheets and subordinate specifications of MIL-DTL-27599. This appendix may also be used to assemble connectors in accordance with other specification sheets and subordinate specifications of MIL-DTL-27599. Installation of other connectors covered in specifications subordinate to the main specification in this appendix shall use the installation requirements in this appendix to the maximum extent practicable.

MS20027 (see 4.6)

MS20028 (see 4.6)

MS27336 (see 4.6)

1. Visual inspection and verification:

- a. Disassemble the connector/backshell assembly.
- b. Verify that the connector is of the correct type and configuration for the cable being terminated in accordance with the system cabling diagram.
- c. Verify that the backshell configuration is of the correct type as specified on the system cabling diagram.
- d. Verify that all component parts of the connector and backshell hardware are present. (See illustration 1 for a typical connector/backshell configuration.) Reference MIL-DTL-27599 for connector, SAE-AS85049 for backshell, or vendor data for specific configurations.

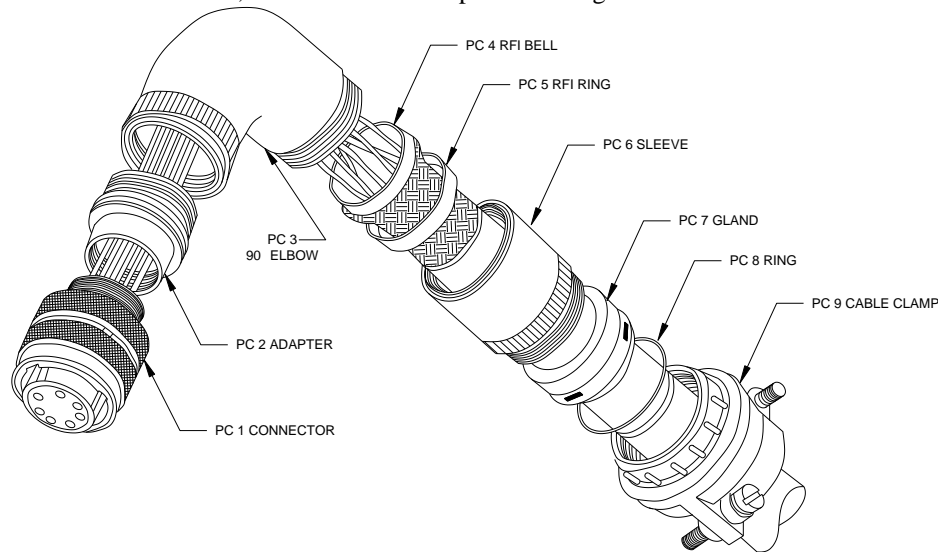

ILLUSTRATION 1
MIL-DTL-27599 CONNECTOR WITH COMPATIBLE BACKSHELL CONFIGURATION

- e. Visually inspect the components for damage such as deformed parts, gouges, damaged threads, cut O-rings, burrs, or surface damage.
 - f. Verify that the contacts meet the requirements of MIL-DTL-27599 and mate properly with their counterpart contacts.
 - g. If the conductors are re-twisted during lead preparation, ensure they are twisted as tight as originally constructed, the natural lay of the conductor is maintained, and the conductors will fit inside the contact barrel.
2. Cable preparation: Prepare the cable in accordance with [figure 5A1](#).
3. While soldering the conductors to the contact, an assembly fixture should be utilized in order to immobilize the cable, conductors, and connector (see illustration 2). The components for an acceptable assembly fixture are as follows: A dummy receptacle, without connector insert, to hold the connector being worked on securely, or a clamping device that will not damage the connector; a cable-clamping fixture to hold the cable in a secure, fixed relationship to the connector while permitting access to the rear face of the connector for the soldering iron; a device (see illustration 2) for holding the wire bundle out of the work area.

NOTE: Equivalent tooling is acceptable; however, the use of other tools may affect the procedural steps outlined below.

FIGURE 5F1. MIL-DTL-27599 connector assembly procedure.

MIL-STD-2003-5B(SH)
APPENDIX 5F

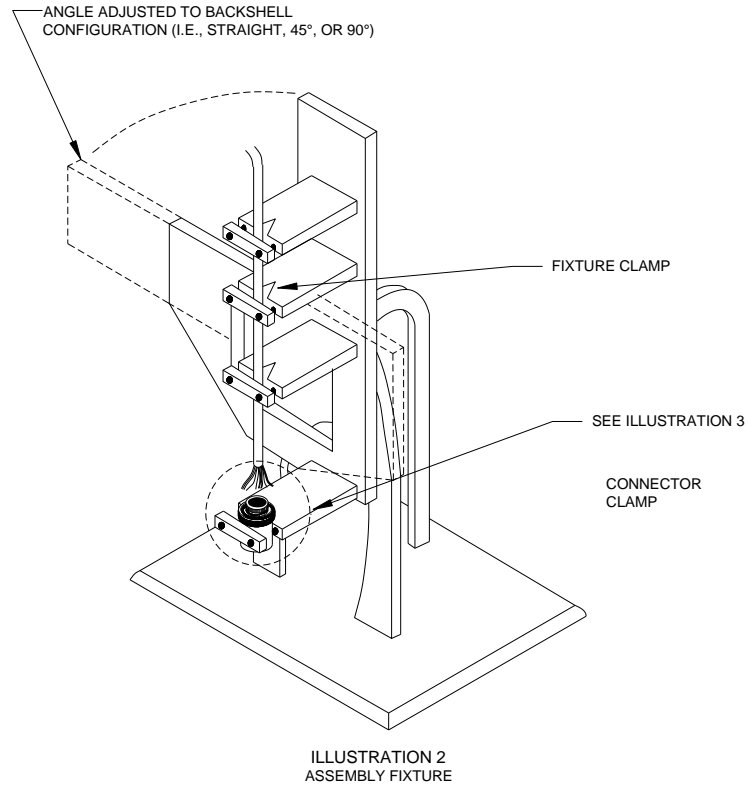

MIL-DTL-27599 connector assembly procedure (continued):

- a. Secure the assembly fixture to a vise or similar holding device in order to provide a stable work area.
- b. Use of this assembly fixture negates the need for a dummy receptacle. Illustration 3 illustrates how the connector is firmly seated in the connector clamp.

FIGURE 5F1. MIL-DTL-27599 connector assembly procedure – Continued.

MIL-STD-2003-5B(SH)
APPENDIX 5F

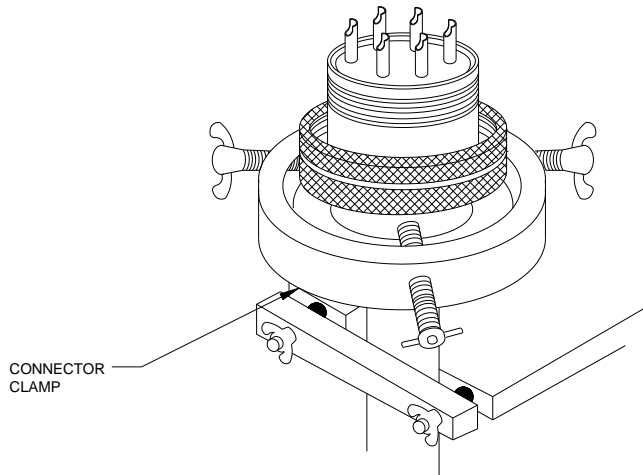

ILLUSTRATION 3
CONNECTOR SEATED IN ASSEMBLY FIXTURE

MIL-DTL-27599 connector assembly procedure (continued):

- c. Seat the connector in the connector clamp and adjust the wing nuts to secure it in place.
 - d. Place the prepared cable in the fixture clamp so that the first contacts to be soldered will be at the back of the connector as it is held in the connector clamp.
 - e. Position the cable at the angle similar to the backshell design (i.e., 45 degrees, 90 degrees, or straight). Secure the cable in the fixture clamp (see illustration 4A).
 - f. Position the connector so that the connector-to-cable jacket distance is that measured in step 9.b of [figure 5A1](#). Rotate the connector to align the keyway position in proper relationship to the backshell (see illustration 4B).
 - g. Route the individual conductors in accordance with the applicable wiring table. Ensure that the longest routed conductor has sufficient length at the required position termination prior to cutting any conductor (see illustration 4C).
 - h. Cut the conductors as required to provide even conductor lengths at the connector insert.
NOTE: Leave the spares full length.
4. Strip the individual conductors in accordance with [figure 5A3](#) (for contact wire barrel depths, see [table 5F1-I](#)).
 - a. If rework shortens a conductor's initial length by greater than ¼ inch, the jacket shall be cut back again and all conductors re-trimmed to prevent stress.

TABLE 5F1-I. Contact wire barrel depths.

Contact size	Wire barrel depth (inches)
22	0.094–0.125
20	0.125–0.156
16	0.141–0.172

FIGURE 5F1. MIL-DTL-27599 connector assembly procedure – Continued.

MIL-STD-2003-5B(SH)
APPENDIX 5F**MIL-DTL-27599 connector assembly procedure (continued):**

5. Tin individual conductors in accordance with [figure 5A5](#). Ensure conductor strands are twisted tight prior to tinning.
6. Solder the conductors to the contacts in accordance with [figure 5A6](#). Soldering should start with the contact row(s) furthest away from the operator. A piece of stiff fire-retardant paper should be inserted between the rows as they are completed to aid in protecting the work already completed (see illustration 5 for example).
WARNING: Do not move the conductor after the soldering iron has been removed or a cold solder joint could result.
 - a. In some cases, a sealing boot is provided with the connector. A sealing boot is a device used to environmentally seal a cable to a specific shielded electrical contact and the electrical contact to the grommet cavity within a connector insert. The boot should be placed onto the cable prior to terminating the contact. Once the contact is installed into the connector, the boot should slide forward into the grommet cavity to seal the contact to the connector. A sealing boot may be required to be supplied with the connector for specified insert arrangements with size 8 shielded contacts. A heat shrink sleeve is not used with a size 8 shielded contact when the sealing boot is used.
 - b. In some cases, a shrink sleeve is provided with the connector. Shrink sleeves (also called “heat shrink boots”) supplied with shielded contacts are used for environmental sealing of the contact to the connector grommet cavity and to the cable. The sleeve should be placed on the cable prior to terminating the contact. Once the cable is terminated, the shrink sleeve should slide over the contact, and heat should be applied to shrink the sleeve and melt the adhesive. Since the maximum temperature rating of a shrink sleeve is 175 °C, a connector with a higher temperature rating should be derated to 175 °C when contacts with shrink sleeves are used.
7. Remove the cable and connector from the assembly fixture.
8. Conduct a visual check of the connector and verify wire location against the wiring table. Ensure no debris is inside socket contacts.
9. Backshell assembly:
NOTE: This connector specification does not provide for unique connector accessory hardware to be utilized with the connectors. The following assembly procedure is based on the nomenclature and hardware configuration depicted in illustration 1. Variations in hardware design based on manufacturer may occur and cause minor deviations from this procedure. Assembly procedures supplied by the backshell manufacturers should be utilized when conflicts exist.

FIGURE 5F1. MIL-DTL-27599 connector assembly procedure – Continued.

MIL-STD-2003-5B(SH)
APPENDIX 5F

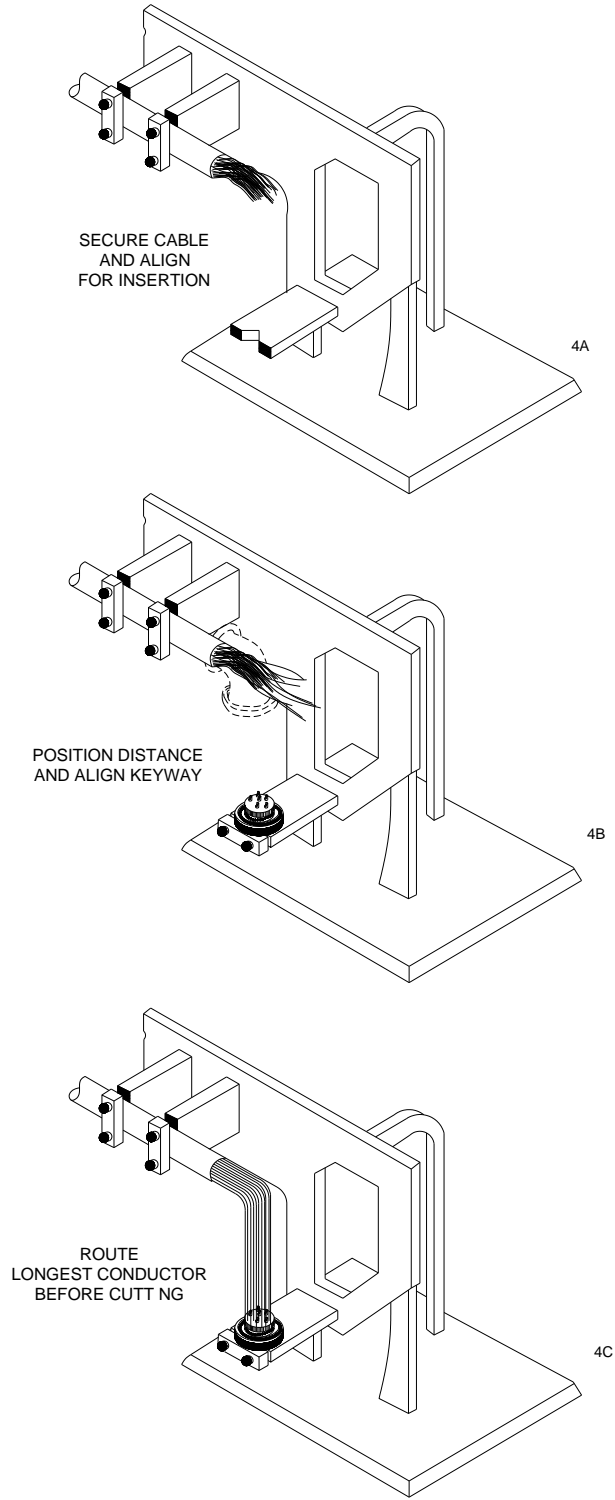

ILLUSTRATION 4
DETERMINING CONDUCTOR LENGTH

FIGURE 5F1. MIL-DTL-27599 connector assembly procedure—Continued.

MIL-STD-2003-5B(SH)
APPENDIX 5F

MIL-DTL-27599 connector assembly procedure (continued):

- a. ~~Fold spare wires back one-half the distance between the connector and the jacket end.~~
- b. Slide a 1-inch long piece of appropriately sized shrink tubing over each folded pair and shrink in place.

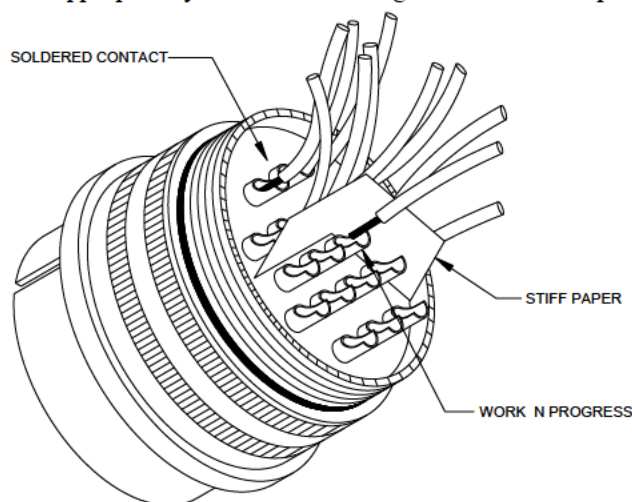
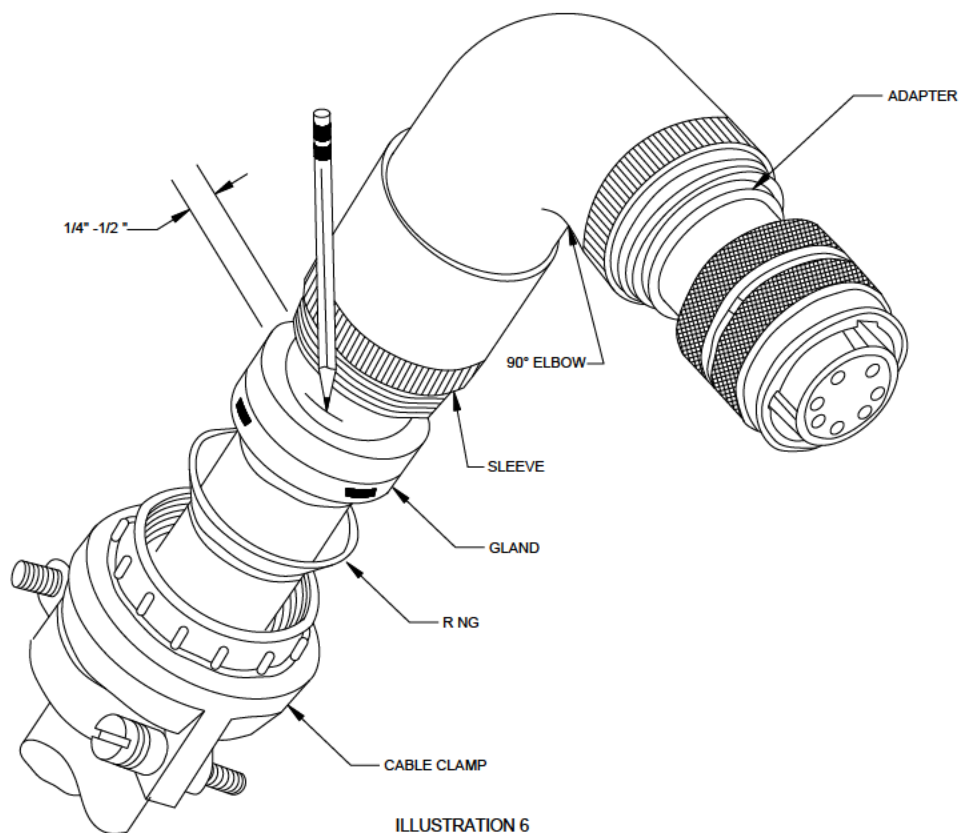

ILLUSTRATION 5
PROTECT NG SOLDERED CONTACTS

- c. Lightly coat the thread of each backshell part with petroleum jelly just prior to using.
- d. Position and lubricate (petroleum jelly) all O-rings.
- e. Slide the backshell adapter (PC 2, illustration 1) down the cable and screw it onto the connector. Tighten the adapter appropriately (see 4.5).
- f. Slide the 90-degree elbow (PC 3, illustration 1) down and screw it onto the adapter. Tighten the elbow appropriately (see 4.5).
- g. If the gross shield is to be floated or terminated to a connector contact, proceed to step 9 h. If the shield is to be terminated to the backshell RFI hardware, proceed as follows:
 - (1) Slide the RFI bell (PC 4, illustration 1) against the elbow.
 - (2) Flare the gross shield over the tapered end of the RFI bell.
 - (3) Gently force the cable toward the connector plug until the shield covers the tapered surface on the RFI bell.
 - (4) Slide the RFI ring (PC 5, illustration 1) onto the RFI bell while applying forward pressure on the cable.
 - (5) Compress the shield between the RFI bell and RFI ring with a back-and-forth twisting forward motion on the RFI ring.
- h. Slide the RFI backshell components (PC 4 and 5, illustration 1) over the pigtails, looped ground wire, and spare conductors.
- i. Slide the sleeve (PC 6, illustration 1) over the RFI assembly and screw the sleeve onto the elbow.
- j. Tighten the sleeve appropriately (see 4.5).
- k. Mark a line on the cable $\frac{1}{4}$ inch- $\frac{1}{2}$ inch above the backshell sleeve (see illustration 6). Carefully push the cable into the backshell $\frac{1}{4}$ inch- $\frac{1}{2}$ inch and maintain continuous pressure to hold at this position for the next four steps. (Line marked on jacket is parallel with backshell sleeve end.)
- l. Verify the cable jacket is positioned completely through the gland.
- m. Slide the gland (PC 7, illustration 1) and ring (PC 8, illustration 1) into position behind the sleeve.
- n. Screw the cable clamp (PC 9, illustration 1) onto the sleeve and tighten appropriately (see 4.5).

FIGURE 5F1. MIL-DTL-27599 connector assembly procedure – Continued.

MIL-STD-2003-5B(SH)
APPENDIX 5F



MIL-DTL-27599 connector assembly procedure (continued):

- o. Alternately tighten the clamping bar screws (see illustration 7) to ensure a minimum gap of $\frac{1}{16}$ inch exists between the clamp support and clamp saddles.

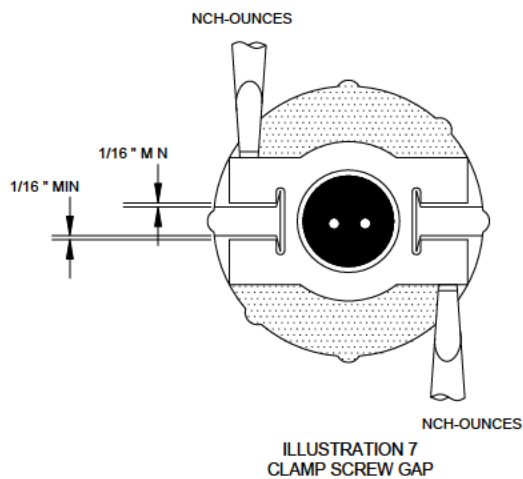

NOTE: If required, install personnel safety ground under clamping bar screw.

FIGURE 5F1. MIL-DTL-27599 connector assembly procedure – Continued.

MIL-STD-2003-5B(SH)
APPENDIX 5F

10. Final test and documentation:
 - a. Perform electrical/electronic checks on the assembled connector (see 4.5).
 - b. Install a protective dust cap on the connector.
 - c. Complete the assembly inspection and documentation as required by local procedures.
11. If necessary, lockwire the connector in accordance with [figure 5A9](#).

FIGURE 5F1. MIL-DTL-27599 connector assembly procedure – Continued.

MIL-STD-2003-5B(SH)
APPENDIX 5G

APPENDIX 5G – MIL-DTL-22992 CONNECTORS

G.1 SCOPE

G.1.1 Scope. This appendix provides instruction for preparing cable in preparation for MIL-DTL-22992 connectors and assembly of such connectors. This appendix is a mandatory part of the standard. The information contained herein is intended for compliance.

G.2 APPLICABLE DOCUMENTS

G.2.1 General. The documents listed in this section are specified in this appendix. This section does not include documents cited in other sections of this standard or recommended for additional information or as examples. While every effort has been made to ensure the completeness of this list, document users are cautioned that they must meet all specified requirements of documents cited in this appendix, whether or not they are listed.

G.2.2 Government documents.

G.2.2.1 Specifications, standards, and handbooks. The following specifications, standards, and handbooks form a part of this document to the extent specified herein. Unless otherwise specified, the issues of these documents are those cited in the solicitation or contract.

DEPARTMENT OF DEFENSE SPECIFICATIONS

MIL-DTL-22992 - Connectors, Plugs and Receptacles, Electrical, Waterproof, Quick Disconnect, Heavy Duty Type, General Specification for

(Copies of this document are available online at <https://quicksearch.dla.mil>.)

G.2.2.2 Other Government documents, drawings, and publications. The following other Government documents, drawings, and publications form a part of this document to the extent specified herein. Unless otherwise specified, the issues of these documents are those cited in the solicitation or contract.

MILITARY SPECIFICATION SHEETS

MS17344 - Connector, Plug, Electrical, Straight

MS17345 - Connector, Plug, Electrical, Cable Connecting, Female

(Copies of these documents are available online at <https://quicksearch.dla.mil>.)

G.2.3 Non-Government publications. The following documents form a part of this document to the extent specified herein. Unless otherwise specified, the issues of these documents are those cited in the solicitation or contract.

SAE INTERNATIONAL

SAE-AS85049 - Connector Accessories, Electrical General Specification for

(Copies of this document are available online at www.sae.org.)

G.2.4 Order of precedence. Unless otherwise noted herein or in the contract, in the event of a conflict between the text of this document and the references cited herein, the text of this document takes precedence. Nothing in this document, however, supersedes applicable laws and regulations unless a specific exemption has been obtained.

G.3 REQUIRED EQUIPMENT AND MATERIALS

G.3.1 Required equipment and materials. The required equipment and materials are specified in the standard methods of this section.

G.4 NOTES AND PROCEDURES

G.4.1 Dimensions. For figures and tables in this appendix, all dimensions are in inches unless otherwise noted.

MIL-STD-2003-5B(SH)
APPENDIX 5G

G.4.2 Figures. [Table 5GI](#) provides information for the figures in this appendix.

TABLE 5GI. Figures for MIL-DTL-22992 connector assembly procedures.

Figure Number	MIL-DTL-22992 Connector Assembly Procedures	Page
5G1	MIL-DTL-22992 connector assembly procedure	178

MIL-STD-2003-5B(SH)
APPENDIX 5G

MIL-DTL-22992 connector assembly procedure (excluding Class L):

List of applicable connectors: The procedures in this appendix specifically cover assembly of connectors in accordance with the following specification sheets and subordinate specifications of MIL-DTL-22992. This appendix may also be used to assemble connectors in accordance with other specification sheets and subordinate specifications of MIL-DTL-22992. Installation of other connectors covered in specifications subordinate to the main specification in this appendix shall use the installation requirements in this appendix to the maximum extent practicable.

MS17344

MS17345

1. Visual inspection and verification:
 - a. Disassemble the connector/backshell assembly.
 - b. Verify that the connector is of the correct type and configuration for the cable being terminated in accordance with the system cabling diagram.
 - c. Verify that the backshell configuration is of the correct type as specified on the system cabling diagram.
 - d. Verify that all component parts of the connector and backshell hardware are present (see illustration 1 for a typical connector/backshell configuration). Reference MIL-DTL-22992 for connector, SAE-AS85049 for backshell, or vendor data for specific configurations.

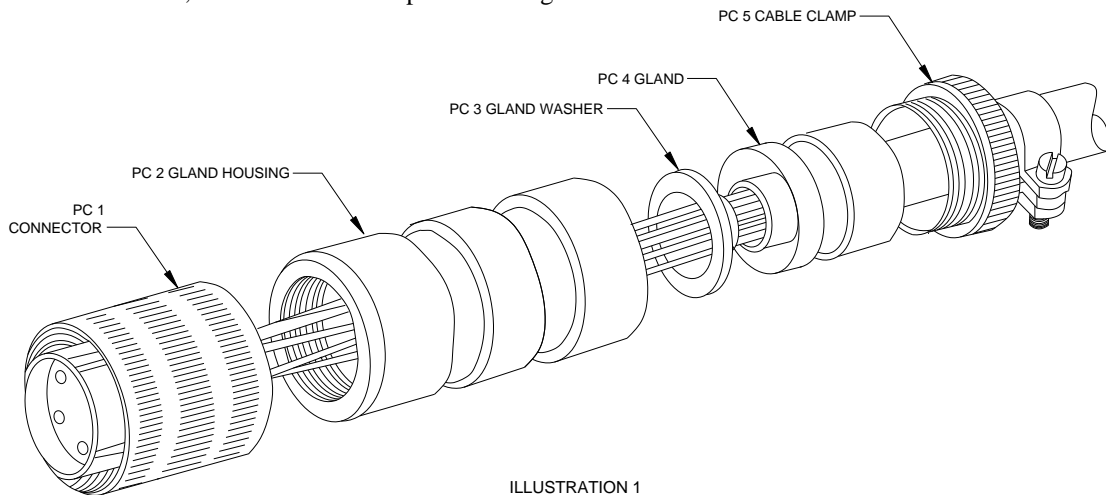
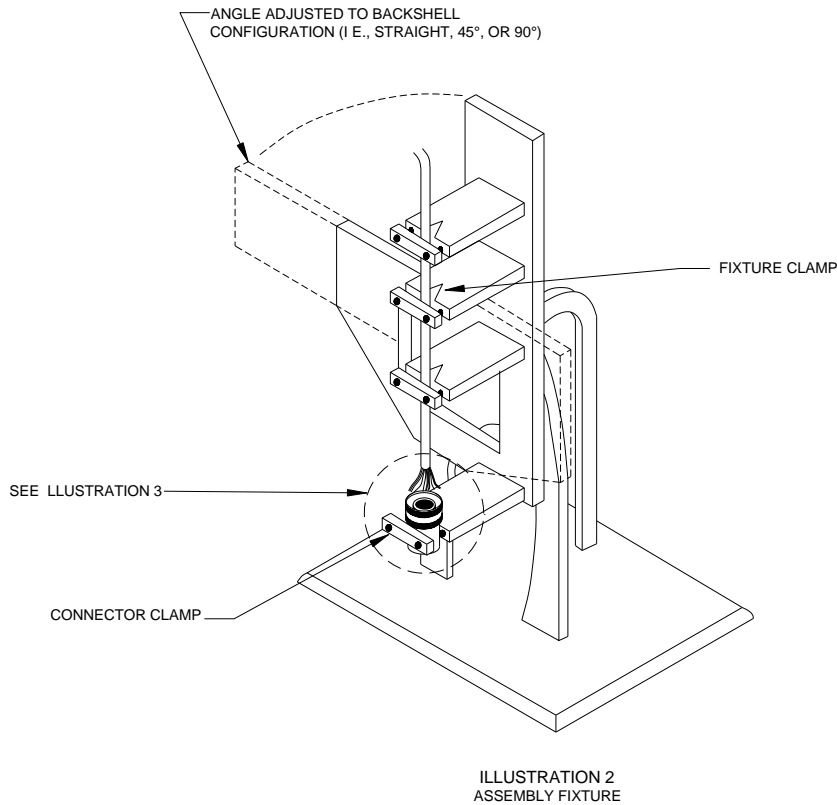

ILLUSTRATION 1
MIL-DTL-22992 CONNECTOR WITH COMPATIBLE BACKSHELL CONFIGURATION

- e. Visually inspect the components for damage such as deformed parts, gouges, damaged threads, cut O-rings, burrs, or surface damage.
 - f. Verify that contacts meet the requirements of MIL-DTL-22992.
 - g. If the conductors are re-twisted during lead preparation, ensure they are twisted as tight as originally constructed, the natural lay of the conductor is maintained, and the conductors will fit inside the contact barrel.
2. Prepare the cable in accordance with [figure 5A1](#).
3. While soldering the conductors to the contacts, an assembly fixture should be utilized in order to immobilize the cable, conductors, and connector (see illustration 2). The components for an acceptable assembly fixture are as follows: A dummy receptacle, without connector insert, to hold the connector being worked on securely, or a clamping device that will not damage the connector; a cable-clamping fixture to hold the cable in a secure, fixed relationship to the connector while permitting access to the rear face of the connector for the soldering iron; a device (see illustration 2) for holding the wire bundle out of the work area.
NOTE: Equivalent tooling is acceptable; however, the use of other tools may affect the procedural steps outlined below.

FIGURE 5G1. MIL-DTL-22992 connector assembly procedure.

MIL-STD-2003-5B(SH)
APPENDIX 5G



MIL-DTL-22992 connector assembly procedure (excluding class L) (continued):

- a. Prepare the connector and cable for soldering as follows:
 - (1) Secure the assembly fixture to a vise or similar holding device.
 - (2) Use of this assembly fixture negates the need for a dummy receptacle. Illustration 3 illustrates how the connector is firmly seated in the connector clamp.

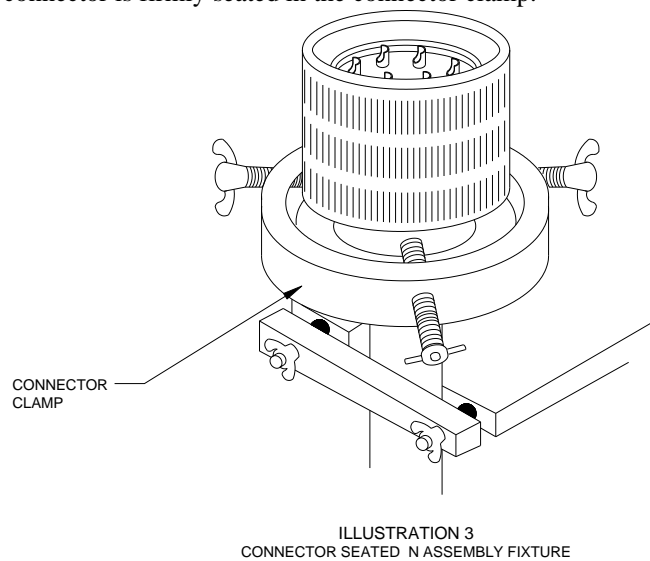
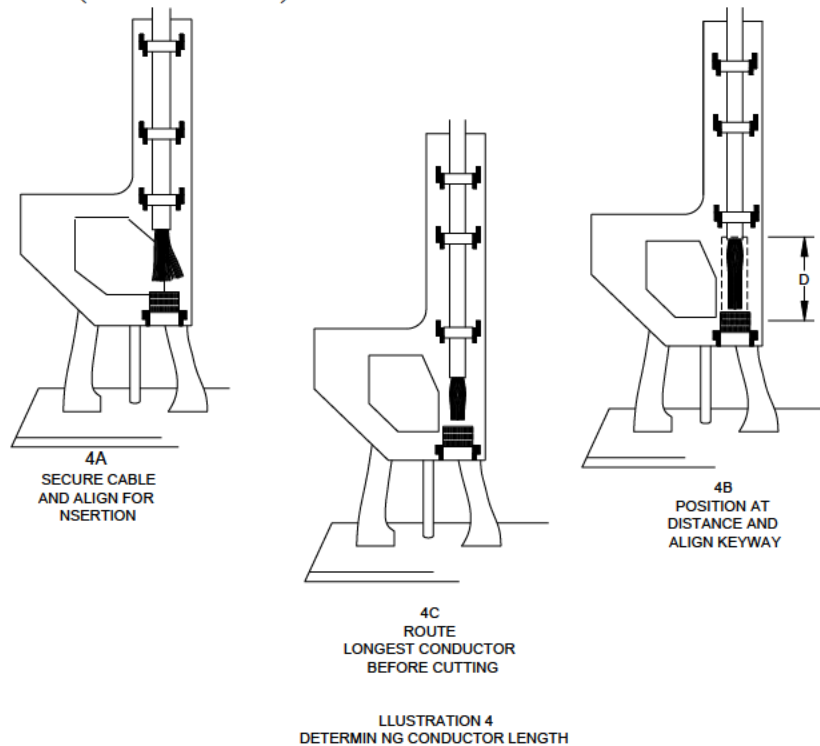

FIGURE 5G1. MIL-DTL-22992 connector assembly procedure – Continued.

MIL-STD-2003-5B(SH)
APPENDIX 5G

MIL-DTL-22992 connector assembly procedure (excluding class L) (continued):

- (3) Seat the connector in the connector clamp and adjust the wing nuts to secure it in place.
- (4) Place the prepared cable in the fixture clamp so that the first contacts to be soldered will be at the back of the connector as it is held in the connector clamp.
- (5) Position the cable at the angle similar to backshell design (i.e., 45 degrees, 90 degrees, or straight). Secure the cable in the fixture clamp (see illustration 4A).
- (6) Position the connector so that the connector-to-cable jacket distance is that measured in step 9.b of [figure 5A1](#). Rotate the connector to align the keyway position in proper relationship to the backshell (see illustration 4B).
- (7) Route the individual conductors in accordance with the applicable wiring table. Ensure that the longest routed conductor has sufficient length at the required position termination prior to cutting any conductor (see illustration 4C).



- b. ~~Cut the conductors as required to provide even conductor lengths at the connector insert.~~
NOTE: Leave the spare leads full length.

TABLE 5G1-I. Contact wire barrel depths.

Contact barrel size	Wire barrel depth (inches)
16	0.250–0.313
12	0.375–0.438
8	0.500–0.563
4	0.625–0.688
0	0.625–0.688

FIGURE 5G1. MIL-DTL-22992 connector assembly procedure – Continued.

MIL-STD-2003-5B(SH)
APPENDIX 5G

MIL-DTL-22992 connector assembly procedure (excluding class L) (continued):

4. Strip the individual conductors in accordance with [figure 5A3](#) (for contact wire barrel depths, see [table 5G1-I](#)).
5. Tin the conductors in accordance with [figure 5A5](#).
 - a. Ensure conductor strands are twisted tight prior to tinning.
 - b. If rework shortens a conductor's initial length by greater than ¼ inch, the jacket shall be cut back again and all leads re-trimmed to preclude stress.
6. Solder the conductors to the contacts in accordance with [figure 5A6](#). Soldering should start with the contact row(s) furthest away from the operator. A piece of stiff fire-retardant paper should be inserted between the rows as they are completed to aid in protecting the work already accomplished (see illustration 5 for example).

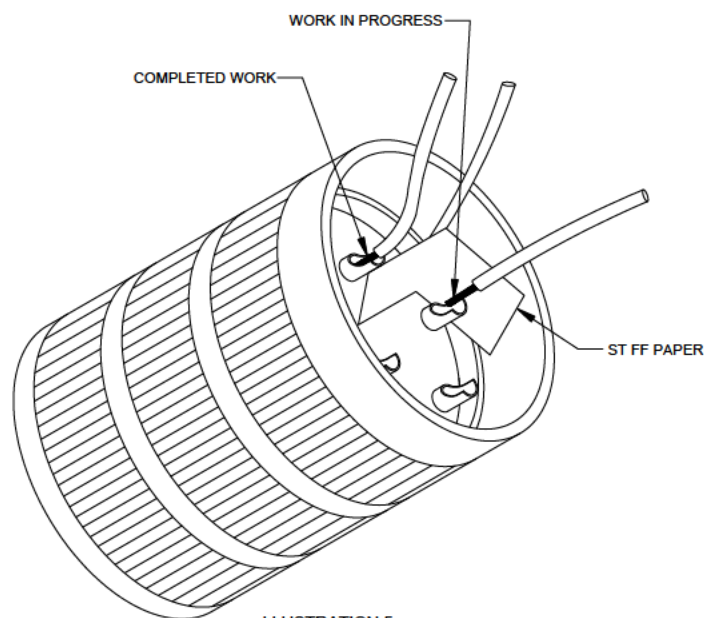

ILLUSTRATION 5
PROTECTING SOLDERED CONTACTS

WARNING: Do not move the conductor after the soldering iron has been removed or a cold solder joint could result.

7. Remove the connector and cable from the assembly fixture.
8. Conduct a visual check of the connector and verify wire location against the wiring table. Ensure no debris is inside socket contacts.
9. Backshell assembly:

NOTE: The following assembly procedure is based on the nomenclature and hardware configuration depicted in illustration 1. Variations in hardware design based on manufacturer may occur and cause minor deviations from this procedure. The applicable manufacturer's instructions should be utilized to resolve assembly procedure conflicts for configurations not covered in this procedure.

 - a. Lubricate the threads of all backshell components with petroleum jelly prior to assembly.
 - b. Fold spare wires back one-half the distance between the connector and the jacket end.
 - c. Slide a 1-inch long piece of appropriately sized shrink tubing over each folded pair and shrink in place.
 - d. Position and lubricate all O-rings.
 - e. Slide the gland housing (PC 2, illustration 1) down the cable and screw it onto the connector. Tighten the gland housing appropriately (see 4.5).

FIGURE 5G1. MIL-DTL-22992 connector assembly procedure – Continued.

MIL-STD-2003-5B(SH)
APPENDIX 5G

MIL-DTL-22992 connector assembly procedure (excluding class L) (continued):

- f. Slide the gland washer (PC 3, illustration 1) and gland (PC 4, illustration 1) into the gland housing. Ensure the cable jacket extends through the area under the gland.
- g. Screw the cable clamp (PC 5, illustration 1) into the gland housing and tighten appropriately (see 4.5).
- h. Alternately tighten (see 4.5) the clamping bar screws (see illustration 6) to ensure a minimum gap of $\frac{1}{16}$ inch exists between the clamp support and clamp saddles.

NOTE: If required, install personnel safety ground under clamping bar screw.

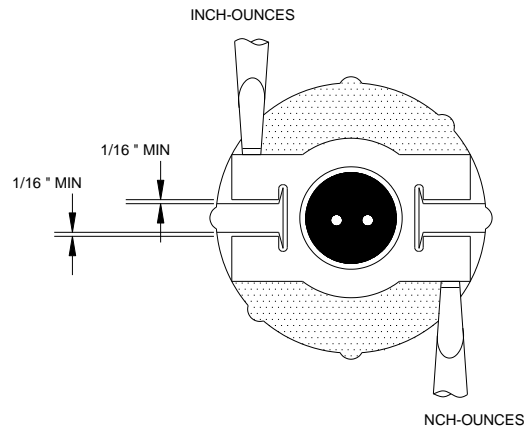

ILLUSTRATION 6

10. Final test and documentation:
 - a. Perform electrical/electronic checks on the assembled connector (see 4.5).
 - b. Install a protective dust cap on the connector.
 - c. ~~Complete the assembly inspection and documentation as required by local procedures.~~
11. If necessary, lockwire the connector in accordance with [figure 5A9](#).

FIGURE 5G1. MIL-DTL-22992 connector assembly procedure – Continued.

MIL-STD-2003-5B(SH)
APPENDIX 5H

APPENDIX 5H – MIL-DTL-38999 CONNECTORS

H.1 SCOPE

H.1.1 Scope. This appendix provides instructions for preparing cable in preparation for MIL-DTL-38999 connectors and assembly of such connectors. This appendix is a mandatory part of the standard. The information contained herein is intended for compliance.

H.2 APPLICABLE DOCUMENTS

H.2.1 General. The documents listed in this section are specified in this appendix. This section does not include documents cited in other sections of this standard or recommended for additional information or as examples. While every effort has been made to ensure the completeness of this list, document users are cautioned that they must meet all specified requirements of documents cited in this appendix, whether or not they are listed.

H.2.2 Government documents.

H.2.2.1 Specifications, standards, and handbooks. The following specifications, standards, and handbooks form a part of this document to the extent specified herein. Unless otherwise specified, the issues of these documents are those cited in the solicitation or contract.

DEPARTMENT OF DEFENSE SPECIFICATIONS

- | | | |
|------------------|---|---|
| MIL-DTL-38999 | - | Connectors, Electrical, Circular, Miniature, High Density, Quick Disconnect (Bayonet, Threaded or Breech Coupling), Environment Resistant with Crimp Removable Contacts or Hermetically Sealed with Fixed, Solderable Contacts, General Specification for |
| MIL-DTL-38999/20 | - | Connectors, Electrical, Circular, Receptacle, Threaded, Wall Mounting Flange, Removable Crimp Contacts, Series III, Metric |
| MIL-DTL-38999/24 | - | Connectors, Electrical, Circular, Receptacle, Threaded, Jam-Nut Mounting, Removable Crimp Contacts, Series III, Metric |
| MIL-DTL-38999/26 | - | Connectors, Electrical, Plug, Circular, Threaded, Straight, Removable Crimp Contacts, Series III, Metric |
| MIL-DTL-38999/28 | - | Connectors, Electrical, Circular, Nut, Hexagon, Connector Mounting, Series III and IV, Metric |
| MIL-DTL-38999/29 | - | Connectors, Electrical, Circular, Threaded, Plug, Lanyard Release, Fail-Safe, Removable Crimp Contacts, Pins, Series III, Metric |
| MIL-DTL-38999/30 | - | Connectors, Electrical, Circular, Threaded, Plug, Lanyard Release, Fail-Safe, Removable Crimp Contacts, Sockets, Series III, Metric |
| MIL-DTL-38999/46 | - | Connectors, Electrical, Circular, Plug, Breech Coupling, EMI Grounding, Removable Crimp Contacts, Series IV, Metric |
| MIL-DTL-38999/47 | - | Connectors, Electrical, Circular, Plug, Breech Coupling, Removable Crimp Contacts, Series IV, Metric |

(Copies of these documents are available online at <https://quicksearch.dla.mil>.)

H.2.2.2 Other Government documents, drawings, and publications. The following other Government documents, drawings, and publications form a part of this document to the extent specified herein. Unless otherwise specified, the issues of these documents are those cited in the solicitation or contract.

MILITARY SPECIFICATION SHEETS

- | | | |
|---------|---|--|
| MS27467 | - | Connectors, Plug, Electrical, Straight, Crimp Type, Bayonet Coupling, Series I |
|---------|---|--|

MIL-STD-2003-5B(SH)
APPENDIX 5H

- MS27468 - Connectors, Receptacle, Electrical, Jam-Nut Mounting, Crimp Type, Bayonet Coupling, Series I
- MS27473 - Connectors, Plug, Electrical, Straight, Crimp Type, Bayonet Coupling, Series II
- MS27484 - Connectors, Plug, Electrical, Straight, Crimp Type, Bayonet Coupling, EMI, Series II
- MS27488 - Plug, End Seal, Electrical Connector
- MS27500 - Connectors, Plug, Electrical, 90° Elbow, Crimp Type, Bayonet Coupling, Series II (see 4.6)
- MS27653 - Connectors, Plug, Electrical, Straight, Crimp Type, Bayonet Coupling, Series I (see 4.6)
- MS27661 - Connectors, Plug, Electrical, Crimp Type, Lanyard Release, Fail-Safe, Series I

(Copies of these documents are available online at <https://quicksearch.dla.mil/>.)

H.2.3 Non-Government publications. The following documents form a part of this document to the extent specified herein. Unless otherwise specified, the issues of these documents are those cited in the solicitation or contract.

SAE INTERNATIONAL

- SAE-AS31971 - Gage Pin for Socket Contact Engagement Test
- SAE-AS39029/56 - Contacts, Electrical Connector, Socket Crimp Removable (for MIL-DTL-38999 Series I, III, and IV Connectors)
- SAE-AS39029/57 - Contacts, Electrical Connectors, Socket Crimp Removable (for MIL-DTL-24308, MIL-DTL-38999 Series II, MIL-DTL-55302/68, /71, /72, /75 and MIL-DTL-83733 Connectors)
- SAE-AS39029/58 - Contacts, Electrical Connector, Pin, Crimp Removable (for MIL-DTL-38999 Series I, II, III, and IV, and MIL-DTL-55302/69 and MIL-DTL-83733 Connectors)
- SAE-AS85049 - Connector Accessories, Electrical General Specification for

(Copies of these documents are available online at www.sae.org/.)

H.2.4 Order of precedence. Unless otherwise noted herein or in the contract, in the event of a conflict between the text of this document and the references cited herein, the text of this document takes precedence. Nothing in this document, however, supersedes applicable laws and regulations unless a specific exemption has been obtained.

H.3 REQUIRED EQUIPMENT AND MATERIALS

H.3.1 Required equipment and materials. The required equipment and materials are specified in the standard methods of this section.

H.4 NOTES AND PROCEDURES

H.4.1 Dimensions. For figures and tables in this appendix, all dimensions are in inches unless otherwise noted.

H.4.2 Figures. [Table 5HI](#) provides information for the figures in this appendix.

MIL-STD-2003-5B(SH)
APPENDIX 5HTABLE 5H1. Figures for MIL-DTL-38999 connector assembly procedures.

Figure Number	MIL-DTL-38999 Connector Assembly Procedures	Page
5H1	MIL-DTL-38999 connector assembly procedure	186

MIL-STD-2003-5B(SH)
APPENDIX 5H

MIL-DTL-38999 connector assembly procedure:

List of applicable connectors: The procedures in this appendix specifically cover assembly of connectors in accordance with the following specification sheets and subordinate specifications of MIL-DTL-38999. This appendix may also be used to assemble connectors in accordance with other specification sheets and subordinate specifications of MIL-DTL-38999. Installation of other connectors covered in specifications subordinate to the main specification in this appendix shall use the installation requirements in this appendix to the maximum extent practicable.

MS27467	MS27653 (see 4.6)	MIL-DTL-38999/28
MS27468	MS27661	MIL-DTL-38999/29
MS27473	MIL-DTL-38999/20	MIL-DTL-38999/30
MS27484	MIL-DTL-38999/24	MIL-DTL-38999/46
MS27500 (see 4.6)	MIL-DTL-38999/26	MIL-DTL-38999/47

1. Visual inspection and verification:

- a. Disassemble the connector/backshell assembly.
- b. Verify that the connector is of the correct type and configuration for the cable being terminated in accordance with the system cabling diagram.
- c. Verify that the backshell configuration is of the correct type as specified on the system cabling diagram.
- d. Verify that all components parts of the connector and backshell hardware are present (see illustration 1 for a typical connector/backshell configuration). Reference specifications shown in list of applicable connectors for connector, SAE-AS85049 for backshell, or vendor data for specific configurations.

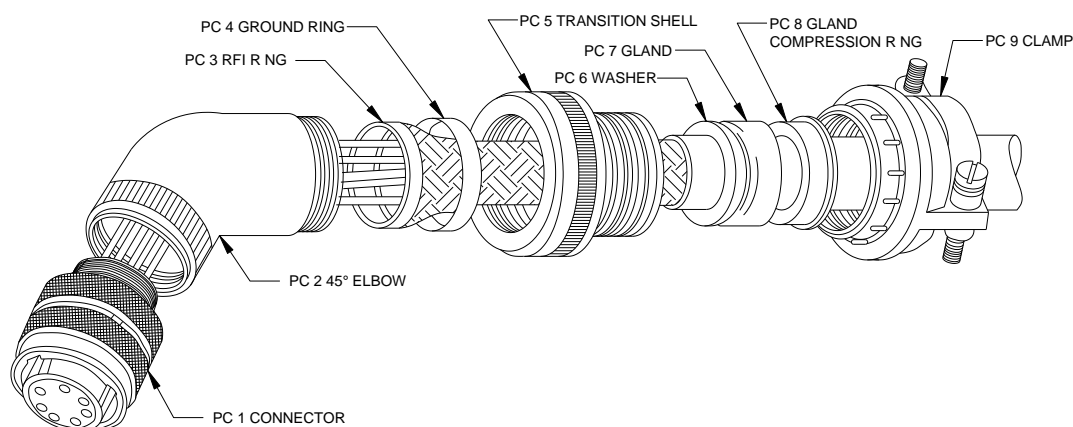

ILLUSTRATION 1
MIL-DTL-38999 CONNECTOR WITH COMPATIBLE BACKSHELL CONFIGURATION

- e. Visually inspect the components for damage such as deformed parts, gouges, damaged threads, cut O-rings, burrs, or surface damage.
 - f. Verify that the crimp contacts meet the requirements of SAE-AS39029/58 for series 1, 2, 3, and 4 pin, SAE-AS39029/56 for series 1, 3, and 4 socket contacts, and SAE-AS39029/57 for series 2 socket contacts and are the correct size and type for the connector being assembled.
 - g. Verify that the solder contacts meet the requirements of MIL-DTL-38999 and mate properly with their counterpart contacts.
 - h. If the conductors are re-twisted during lead preparation, ensure they are twisted as tight as originally constructed, the natural lay of the conductor is maintained, and the conductors will fit inside the contact barrel (PC 2, illustration 1).
2. Prepare the cable in accordance with [figure 5A1](#).

FIGURE 5H1. MIL-DTL-38999 connector assembly procedure.

MIL-STD-2003-5B(SH)
APPENDIX 5H

MIL-DTL-38999 connector assembly procedure (continued):

3. Insertion setup: Owing to the many possible variations for acceptable tooling for contact insertion and soldering, no specification is made as to a particular type. The criteria, that are desirable for an acceptable assembly fixture, are as follows: A dummy receptacle, without connector insert, to hold the connector being worked on securely or a clamping device that will not damage the connector; a cable clamping fixture to hold the cable in a secure, fixed relationship to the connector while permitting access to the rear face of the connector for the contact insertion tool or soldering iron; a device (see illustration 2) for holding the wire bundle out of the work area.

NOTE: Equivalent tooling is acceptable; however, the use of other tools may affect the procedural steps outlined below.

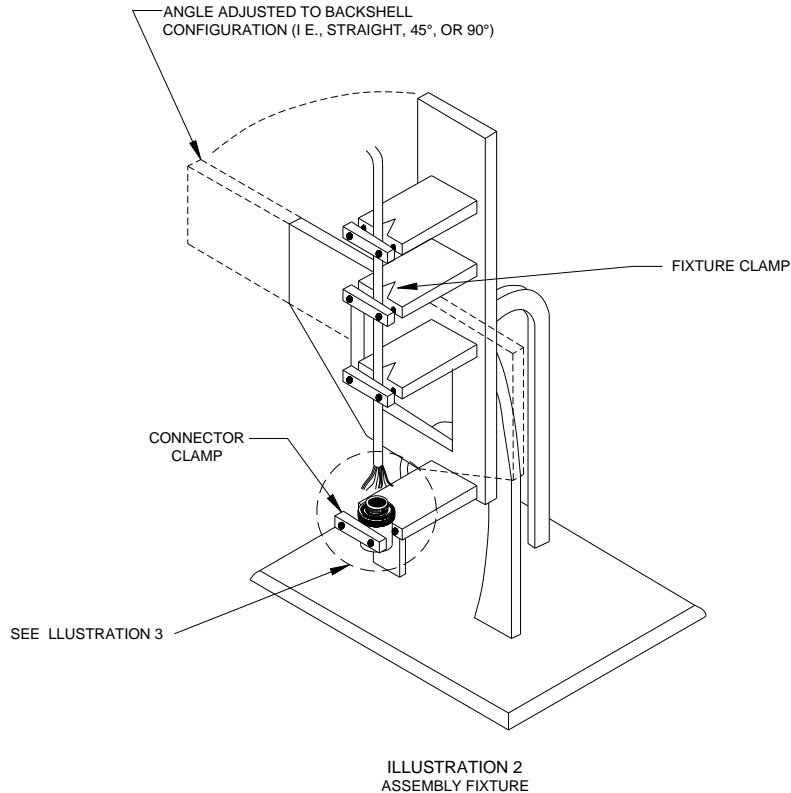

- a. Secure the assembly fixture to a vise or similar holding device in order to provide a stable work area.
- b. Use of this assembly fixture negates the need for a dummy receptacle. Illustration 3 illustrates how the connector is firmly seated in the connector clamp.

FIGURE 5H1. MIL-DTL-38999 connector assembly procedure – Continued.

MIL-STD-2003-5B(SH)
APPENDIX 5H

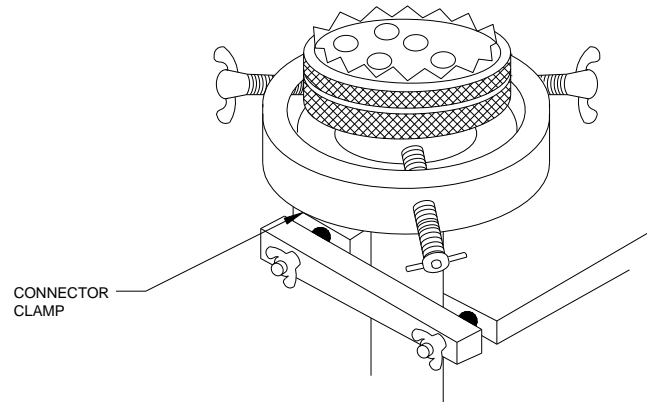

ILLUSTRATION 3
CONNECTOR SEATED IN ASSEMBLY FIXTURE

MIL-DTL-38999 connector assembly procedure (continued):

- c. Seat the connector in the connector clamp, and adjust the wing nuts to secure it in place.
- d. Place the prepared cable in the fixture clamp so that the first contacts to be inserted will be at the back of the connector as it is held in the connector clamp.

FIGURE 5H1. MIL-DTL-38999 connector assembly procedure – Continued.

MIL-STD-2003-5B(SH)
APPENDIX 5H

SECURE CABLE
AND ALIGN
FOR INSERTION

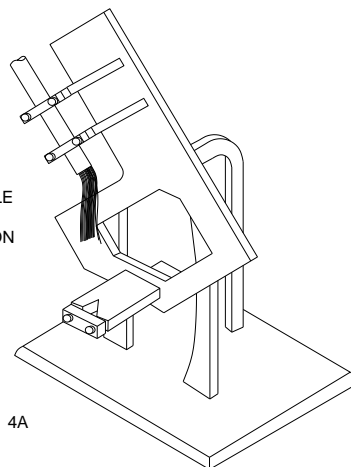

4A

POSITION DISTANCE
AND ALIGN
KEYWAY

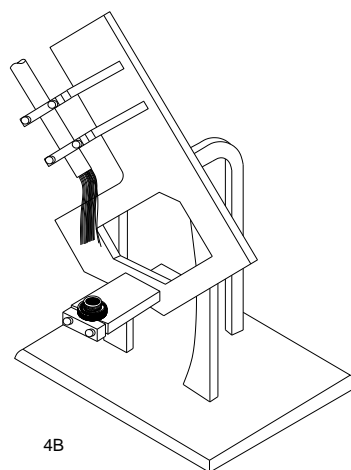

4B

ROUTE LONGEST
CONDUCTOR BEFORE
CUTTING

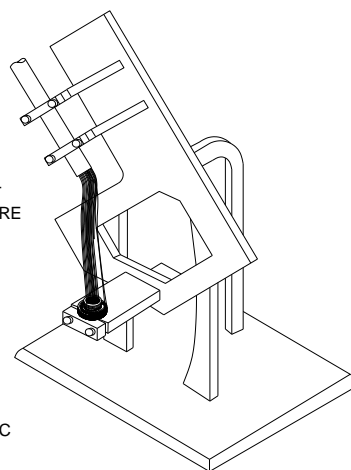

4C

ILLUSTRATION 4
DETERMINING CONDUCTOR LENGTH

FIGURE 5H1. MIL-DTL-38999 connector assembly procedure – Continued.

MIL-STD-2003-5B(SH)
APPENDIX 5H

MIL-DTL-38999 connector assembly procedure (continued):

- e. Position the cable at the angle similar to backshell design (i.e., 45 degrees, 90 degrees, or straight). Secure the cable in the fixture clamp (see illustration 4A).
 - f. Position the connector so that the connector-to-cable jacket distance is that measured in step 9.b of [figure 5A1](#). Rotate the connector to align the keyway position in proper relationship to the backshell (see illustration 4B).
 - g. Route the individual conductors in accordance with the applicable wiring table. Ensure that the longest routed conductor has sufficient length at the required position termination prior to cutting any conductor (see illustration 4C).
 - h. Cut the conductors as required to provide even conductor lengths at the connector insert.
NOTE: Leave the spare leads full length.
4. Strip the individual conductors in accordance with [figure 5A3](#) (for contact wire barrel depths, see [table 5H1-I](#)).

TABLE 5H1-I. Contact wire barrel depths.

Contact barrel size	Wire barrel depth (inches)	
	Front release	Rear release
12-12	0.209–0.229	0.141–0.172
16-16	0.209–0.229	0.141–0.172
20-20	0.209–0.229	0.125–0.156
22-22	0.141–0.157	0.094–0.125
22-22M	0.141–0.157	0.094–0.125
22-22D	0.141–0.157	0.094–0.125

NOTE: For solder contacts, proceed to step 6.

5. Crimp contact termination to connector:
 - a. Prior to crimping, a contact-sizing test should be accomplished for all socket contacts (pin contacts previously verified in step 1 f do not need further testing). Socket contacts should be inspected for proper size using a pin contact gauge conforming to SAE-AS31971.

FIGURE 5H1. MIL-DTL-38999 connector assembly procedure – Continued.

MIL-STD-2003-5B(SH)
APPENDIX 5H

TABLE 5H1-II. Crimp tool guide.

Contact size	Series 1, 2, 3 4 pin contact		Series 1, 2, 3, 4 socket contact		Minimum separation force (ounces)
	Basic crimping tool	Positioner	Basic crimping tool	Positioner	
12-12	M22520/1-01	M22520/1-04 yellow	M22520/1-01	M22520/1-04 yellow	2.5
16-16	M22520/1-01	M22520/1-04 blue	M22520/1-01	M22520/1-04 blue	1.5
	M22520/7-01	M22520/7-04	M22520/7-01	M22520/7-04	
20-20	M22520/1-01	M22520/1-04 red	M22520/1-01	M22520/1-04 red	0.6
	M22520/2-01	M22520/2-10	M22520/2-01	M22520/2-10	
	M22520/7-01	M22520/7-08	M22520/7-01	M22520/7-08	
22-22 22-22M 22-22D	M22520/2-01	M22520/2-09	M22520/2-01	M22520/2-07	0.6
				M22520/2-06*	
	M22520/7-01	M22520/7-07	M22520/7-01	M22520/7-05	
				M22520/7-06*	

* Series 2 socket contacts only.

MIL-DTL-38999 connector assembly procedure (continued):

- b. Terminate individual conductors with crimp contacts in accordance with [figure 5A4](#). See [table 5H1-II](#) for proper crimping tool. If contact rework shortens a conductor's initial length by greater than ¼ inch, the jacket shall be cut back again and all conductors re-trimmed to avoid stress.
- c. Inserting contacts (see illustration 5).

FIGURE 5H1. MIL-DTL-38999 connector assembly procedure – Continued.

MIL-STD-2003-5B(SH)
APPENDIX 5H

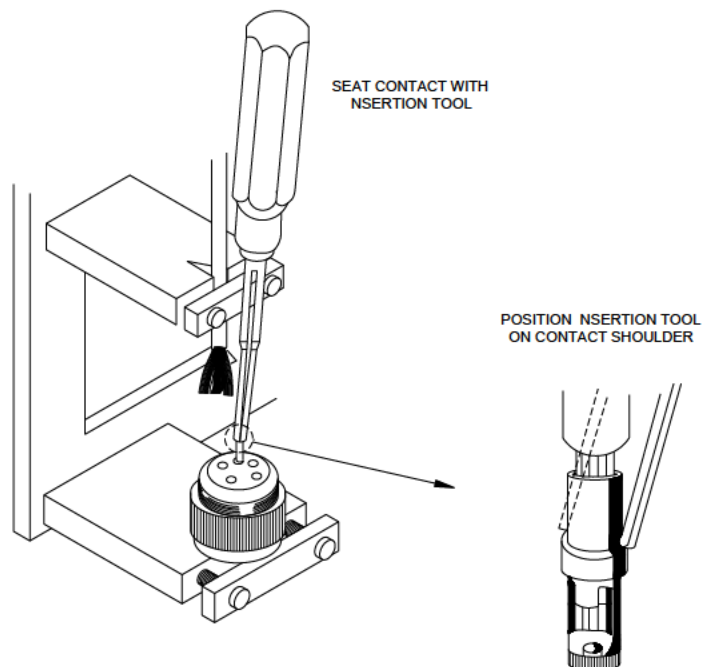

ILLUSTRATION 5
CONTACT INSERTION

MIL-DTL-38999 connector assembly procedure (continued):

- (1) Using the proper wiring table, proper insertion tool based on contact type (see [table 5H1-III](#)), and working from the rear to the front of the assembly fixture, insert the contacts into their designated locations in the connector as follows:

TABLE 5H1-III. Installation and removal tools.

Contact size	Installing tool	Removal tool
12-12	M81969/8-09	M81969/8-10
	M81969/14-04	M81969/14-04
16-16	M81969/8-07	M81969/8-08
	M81969/14-03	M81969/14-03
20-20	M81969/8-05	M81969/8-06
	M81969/14-02	M81969/14-02
22-22	M81969/8-03	M81969/8-04
22-22M	M81969/8-01	M81969/8-02
	M81969/14-01	M81969/14-01
22-22D	M81969/8-01	M81969/8-02
	M81969/14-01	M81969/14-01

FIGURE 5H1. MIL-DTL-38999 connector assembly procedure – Continued.

MIL-STD-2003-5B(SH)
APPENDIX 5H

MIL-DTL-38999 connector assembly procedure (continued):

- (a) Position the contact in the tool. The tool tip should be against the contact shoulder just forward of the wire barrel.
 - (b) Insert the contact and tool tip into the contact cavity with a firm steady pressure.
 - (c) Slide the insertion tool back along the wire until it clears the connector insert. Lightly pull on the inserted lead to ensure the contact is locked in the connector.
 - (d) Adjust the fixture clamp as required during the insertion process to ease stress on the conductors.
 - (e) Ensure that the shield ground wire (if terminated to a contact) is inserted in its proper location.
 - (f) Upon insertion of each two rows of pin contacts, visually inspect the connector face to ensure that the contacts are properly inserted and do not “cross over” into adjacent pin holes. Any improperly inserted contacts will appear angled when compared to the properly inserted contacts.
 - (g) Insert sealing plugs, if required, meeting the requirements of MS27488 into all unwired contact holes. Sealing plugs are required for environmental connectors, but not for non-environmental connectors.
 - (h) In some cases, a sealing boot is provided with the connector. A sealing boot is a device used to environmentally seal a cable to a specific shielded electrical contact and the electrical contact to the grommet cavity within a connector insert. The boot should be placed onto the cable prior to terminating the contact. Once the contact is installed into the connector, the boot should slide forward into the grommet cavity to seal the contact to the connector. A sealing boot may be required to be supplied with the connector for specified insert arrangements with size 8 shielded contacts. A heat shrink sleeve is not used with a size 8 shielded contact when the sealing boot is used.
 - (i) In some cases, a shrink sleeve is provided with the connector. Shrink sleeves (also called “heat shrink boots”) supplied with shielded contacts are used for environmental sealing of the contact to the connector grommet cavity and to the cable. The sleeve should be placed on the cable prior to terminating the contact. Once the cable is terminated, the shrink sleeve should slide over the contact, and heat should be applied to shrink the sleeve and melt the adhesive. Since the maximum temperature rating of a shrink sleeve is 175 °C, a connector with a higher temperature rating should be derated to 175 °C when contacts with shrink sleeves are used.
- d. Remove the connector and cable from the assembly fixture.
 - e. Conduct a visual check of the connector and verify wire location against the wiring table. Ensure no debris is inside socket contacts.
 - f. Contact removal procedure (as required).
 - (1) Conduct a visual check of the connector face to identify any unseated contacts.
 - (2) If required to remove contacts, proceed as follows (see illustration 6):
 - (a) Select the correct removal tool from [table 5H1-III](#).
 - (b) Straddle the wire of the contact to be removed with the removal tool.
 - (c) Slide the tool into the insert until bottomed around the contact.
CAUTION: Do not twist the extractor tool.
 - (d) Remove the contact and tool slowly from the connector.
 - (e) Examine the connector and contact for damage.
 - (f) Reinsert all extracted contacts and repeat the seating checks.

FIGURE 5H1. MIL-DTL-38999 connector assembly procedure – Continued.

MIL-STD-2003-5B(SH)
APPENDIX 5H

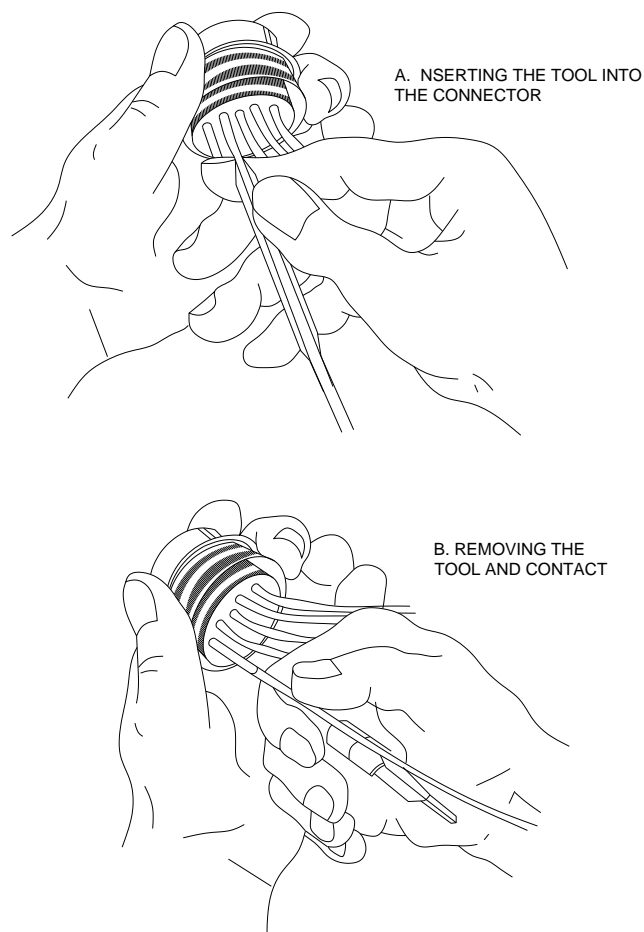

ILLUSTRATION 6
CONTACT REMOVAL (REAR RELEASE)

MIL-DTL-38999 connector assembly procedure (continued):

- (3) If a contact fails to reseat after three insertion attempts, replace the offending contact. If the same contact location continues to give difficulty, the connector is probably damaged or faulty and shall be replaced.
6. Solder termination to connector:
 - a. Tin the conductors in accordance with [figure 5A5](#).
 - (1) Ensure conductor strands are twisted tight prior to tinning.
 - (2) If rework shortens a conductor's initial length by greater than ¼ inch, the jacket shall be cut back again and all leads re-trimmed to preclude stress.
 - b. Solder the conductors to the contacts in accordance with [figure 5A6](#). Soldering should start with the contact row(s) furthest away from the operator. A piece of stiff fire-retardant paper should be inserted between the rows as they are completed to aid in protecting the work already accomplished (see illustration 8 for example).

FIGURE 5H1. MIL-DTL-38999 connector assembly procedure – Continued.

MIL-STD-2003-5B(SH)
APPENDIX 5H

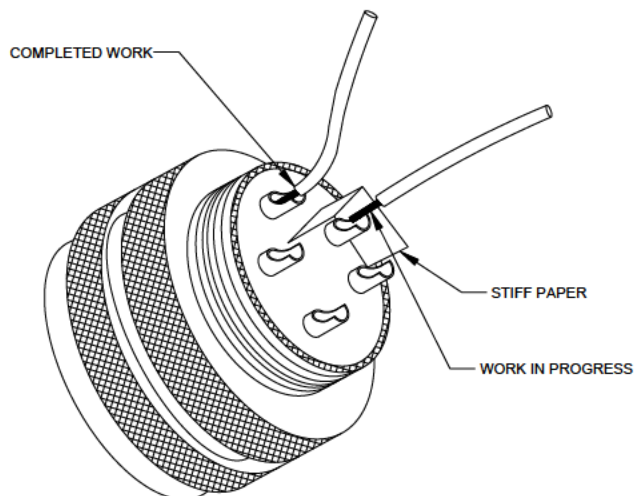

ILLUSTRATION 7
PROTECTING SOLDERING CONTACTS

MIL-DTL-38999 connector assembly procedure (continued):

WARNING: Do not move the conductor after the soldering iron has been removed or a cold solder joint could result.

- c. Remove the cable and connector from the assembly fixture.
- d. Conduct a visual check of the connector and verify wire location against the wiring table. Ensure no debris is inside socket contacts.

7. Backshell assembly:

NOTE: This connector specification does not provide for unique connector accessory hardware to be utilized with the connectors. The following assembly procedure is based on the nomenclature and hardware configuration depicted in illustration 1. Variations in hardware design based on manufacturer may occur and cause minor deviations from this procedure. Assembly procedures supplied by the backshell manufacturers should be utilized when conflicts exist.

- a. Fold spare wires back one-half the distance between the connector and the jacket end.
- b. Slide a 1-inch long piece of appropriately sized shrink tubing over each folded pair and shrink in place.
- c. Lightly coat the threads of each backshell part with petroleum jelly just prior to assembly.
- d. Position and lubricate petroleum jelly all O-rings.
- e. Slide the 45-degree elbow (PC 2, illustration 1) down the cable and screw it onto the connector. Tighten the 45-degree elbow appropriately (see 4.5).

FIGURE 5H1. MIL-DTL-38999 connector assembly procedure – Continued.

MIL-STD-2003-5B(SH)
APPENDIX 5H

MIL-DTL-38999 connector assembly procedure (continued):

- f. If the gross shield is to be floated or terminated to a connector contact, proceed to step 7.g. If the shield is to be terminated to the backshell RFI hardware, proceed as follows:
 - (1) Slide the RFI ring (PC 3, illustration 1) against the elbow.
 - (2) Flare the gross shield over the tapered end of the RFI ring.
 - (3) Gently force the cable toward the connector plug until the shield covers the tapered surface on the RFI ring.
 - (4) Slide the ground ring (PC 4, illustration 1) onto the RFI ring while applying forward pressure on the cable.
 - (5) Compress the shield between the RFI ring and ground ring with a back and forth twisting forward motion on the ground ring.
- g. If the gross shield is floated or terminated to a connector contact, slide the RFI backshell components (PC 3 and 4, illustration 1) over the pigtails, looped ground wire, and spare conductors.
- h. Slide the transition shell (PC 5, illustration 1) over the RFI assembly and screw it onto the elbow.
- i. Tighten the transition shell appropriately (see 4.5).
- j. Mark a line on the cable $\frac{1}{4}$ inch- $\frac{1}{2}$ inch above the backshell transition shell (see illustration 9). Carefully push the cable into the gland $\frac{1}{4}$ inch- $\frac{1}{2}$ inch and maintain continuous pressure to hold at this position for the next four steps. (Line marked on jacket is even with transition shell rear edge.)

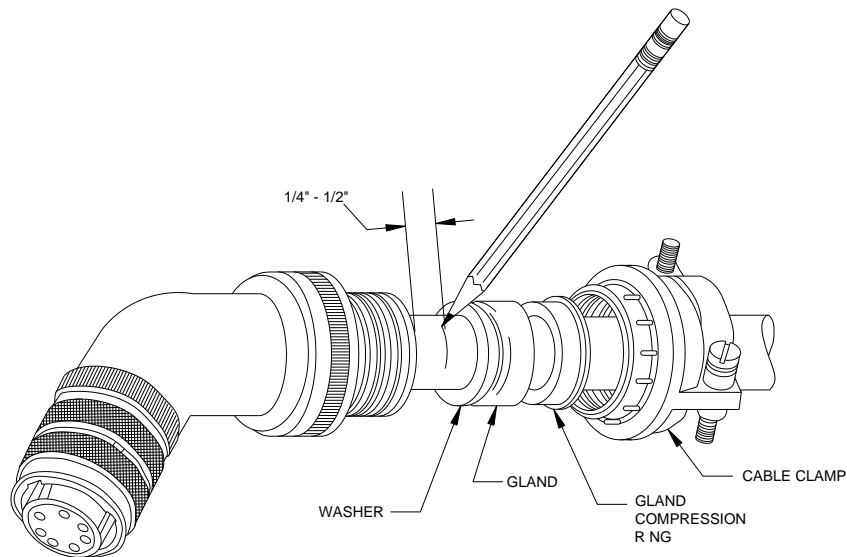

ILLUSTRATION 8
MARKING THE CABLE

- k. Verify the cable jacket is positioned completely through the gland.
- l. Slide the washer (PC 6, illustration 1), gland (PC 7, illustration 1), and gland compression ring (PC 8, illustration 1) into the position behind the transition shell.
- m. Screw the cable clamp (PC 9, illustration 1) onto transition shell and tighten appropriately (see 4.5).
- n. Alternately tighten (see 4.5) the clamping bar screws (see illustration 10) to ensure a minimum gap of $\frac{1}{16}$ inch exists between the clamp support and clamp saddles.

NOTE: If required, install personnel safety ground under clamping bar screw.

FIGURE 5H1. MIL-DTL-38999 connector assembly procedure – Continued.

MIL-STD-2003-5B(SH)
APPENDIX 5H

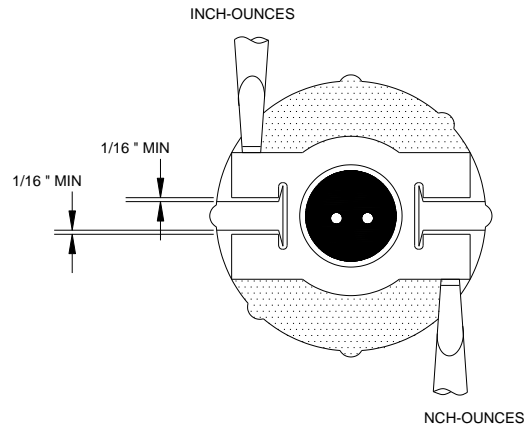

ILLUSTRATION 9
CLAMPING BAR ADJUSTMENT

MIL-DTL-38999 connector assembly procedure (continued):

8. Final test and documentation:
 - a. Perform electrical/electronic checks on the assembled connector (see 4.5).
 - b. Install a protective dust cap on the connector.
 - c. Complete the assembly inspection and documentation as required by local procedures.
9. If necessary, lockwire the connector in accordance with [figure 5A9](#).

FIGURE 5H1. MIL-DTL-38999 connector assembly procedure – Continued.

MIL-STD-2003-5B(SH)

CONCLUDING MATERIAL

Preparing activity:
Navy – SH
(Project SESS-2015-031)

NOTE: The activities listed above were interested in this document as of the date of this document. Since organizations and responsibilities can change, you should verify the currency of the information above using the ASSIST Online database at <https://assist.dla.mil>.