

METRIC

MIL-STD-1474D
12 February 1997
SUPERSEDING
(See Section 6.4)

DEPARTMENT OF DEFENSE DESIGN CRITERIA STANDARD

NOISE LIMITS



MIL-STD-1474D

FOREWORD

1. This standard has been approved for use by all Departments and Agencies of the Department of Defense.
2. Three different types of "noise criteria" used to limit noise exposure have evolved:
 - a. Hearing damage-risk criteria (DRC) are comprehensive statements of the relation between various descriptive parameters of the noise exposure (e.g., sound pressure level, exposure time) and the probability of temporary or permanent hearing loss. DRC are statements regarding the probability of hearing loss resulting from noise exposure in specified proportions of the population. DRC serve as the data base for developing hearing conservation criteria and materiel design standards. Examples of current DRC are *Hazardous Exposure to Intermittent and Steady-State Noise* (1965) and *Proposed Damage-Risk Criterion for Impulse Noise (Gunfire)* (1968), both published by the National Academy of Sciences-National Research Council Committee on Hearing, Bioacoustics and Biomechanics, Washington, D.C.
 - b. Hearing conservation criteria are noise exposure limits that, when exceeded, indicate the need for hearing conservation measures. In the Army these criteria, as well as guidelines for conducting comprehensive hearing conservation programs, are contained in DA PAM 40-501, *Hearing Conservation*. DA PAM 40-501 contains information on noise and hearing conservation programs applicable to both military and civilian personnel of the Army; provides guidance for medical officers, occupational physicians, audiologists, and other personnel of the Army Medical Department concerned with implementing these programs; outlines implementation of educational aspects of these programs; and identifies the roles of command and of all levels of supervision in these programs. Navy criteria and guidelines for conducting hearing conservation programs are found in OPNAVINST 5100.23B, *Navy Occupational Safety and Health (NAVOSH) Program Manual*, and OPNAVINST 5100.19B, *NAVOSH Program Manual for Forces Afloat*. Air Force criteria are contained in AFOSHSTD 48-19, *Hazardous Noise Program*.
 - c. Materiel design standards provide specific noise limits and other requirements to equipment designers and manufacturers. They are intended to cover typical operational conditions. Required noise limits must not be exceeded if the materiel is to be acceptable to the procuring activity. Design standards evolve from considerations of hearing damage-risk, speech intelligibility, aural detection, state-of-the-art of noise reduction, and government legislation.
3. It is important to distinguish among the three types to choose the proper one for application and use in various situations. This document is based on the provisions of DA PAM 40-501, OPNAVINST 5100.23B, OPNAVINST 5100.19B, and AFOSHSTD 48-19 for noise exposure criteria and MIL-STD-1472 for communications criteria.
4. This standard is neither a hearing damage risk criterion nor a hearing conservation criterion. It is a set of design criteria.
5. The criteria contained herein are more stringent than Occupational Safety and Health Administration (OSHA) standards and will be used in lieu of OSHA standards (29 CFR 1910.95). Whenever feasible, all new equipment, whether newly designed or purchased, shall emit the lowest possible noise levels.
6. The acoustical noise provisions for fixed wing aircraft are structured to draw attention to aspects of the design where tailoring of requirements is necessary or possible.
7. Beneficial comments (recommendations, additions, deletions) and any pertinent data which may be of use in improving this document should be addressed to Commander, U.S. Army

MIL-STD-1474D

Missile Command, ATTN: AMSMI-RD-SE-TD-ST, Redstone Arsenal, AL 35898-5270 by using the Standardization Document Improvement Proposal (DD Form 1426) appearing at the end of this document or by letter.

MIL-STD-1474D

CONTENTS

<u>PARAGRAPH</u>		<u>PAGE</u>
1	SCOPE	1
1.1	Scope	1
1.2	Applicability	1
1.3	Intended use	1
2	APPLICABLE DOCUMENTS	1
2.1	General	1
2.2	Government documents	1
2.3	Non-Government publications	2
2.4	Order of precedence	3
3	DEFINITIONS	3
4	GENERAL REQUIREMENTS	3
5	DETAILED REQUIREMENTS	5
6	NOTES	6
6.1	Intended use	6
6.2	Issue of DoDISS	6
6.3	Associated Data Item Descriptions (DIDs)	6
6.4	Supersession data	6
6.5	Subject term (key word) listing	9
6.6	Changes from previous issue	9
6.7	Guidance documents	9
	INDIVIDUAL REQUIREMENTS	
	Requirement 1 - Steady-state noise, personnel occupied areas	11
	Requirement 2 - Aural nondetectability	20
	Requirement 3 - Community Annoyance	33
	Requirement 4 - Impulse noise, personnel occupied areas	35
	Requirement 5 - Shipboard equipment noise	49
	Requirement 6 - Aircraft noise	65
	Requirement 7 - Rotary-wing aircraft noise	71
	<u>FIGURE</u>	
1	Noise hazard caution sign	4
2	Sample form showing acoustical test data for M561 cargo truck	7
3	Blank acoustical test data form	8
2-1	Level I nondetectability limits for 10 - 30 meters	27
2-2	Level I nondetectability limits for 100 - 400 meters	28
2-3	Level I nondetectability limits for 500 - 6000 meters	29
2-4	Level II nondetectability limits for 10 - 30 meters	30
2-5	Level II nondetectability limits for 100 - 400 meters	31
2-6	Level II nondetectability limits for 500 - 6000 meters	32
4-1	Peak sound pressure levels and B-duration limits for impulse noise	38
4-2	Sample determination of B-duration	44

MIL-STD-1474D

<u>FIGURE</u>		<u>PAGE</u>
4-3	Sample determination of B-duration	45
4-4	Sample determination of B-duration	46
4-5	Sample determination of B-duration	47
4-6	Determination of B-duration	48
5-1	Sound measurement locations for small equipment, in addition to location of operator's head	60
5-2	Sound measurement locations for medium size equipment, in addition to location of operator's head	61
5-3	Sound measurement locations for large equipment	62
5-4	Sound measurement locations for valves	63
5-5	Standard test fixture	64
7-1	Size and wording of stencil	73
 <u>TABLE</u>		
1-I	Steady-state noise categories	12
1-II	Steady-state noise limits (dBA) for personnel-occupied areas	13
2-I	Level I aural nondetectability limits (dB)	22
2-II	Level II aural nondetectability limits (dB)	23
2-III	Frequency (Hz) and accompanying 1/3 octave band ambient noise levels (dB) for both level I and level II categories	24
3-I	Sound level limits and test procedures for community annoyance	34
4-I	Impulse noise daily exposure limits	36
5-I	Acceptable octave band sound pressure levels in dB re 20 mPa	51
5-II	Equivalent A-weighted sound levels	52
6-I	Noise limits for unprotected exposures	66
7-I	Helicopter sound pressure level (dB) design limits	74
 <u>APPENDIX</u>		
A	Guidance for Requirement 6	79
B	Hearing protector noise attenuation	97

MIL-STD-1474D

1. SCOPE

1.1 Scope. This standard establishes acoustical noise limits and prescribes testing requirements and measurement techniques for determining conformance to the noise limits specified herein.

1.2 Applicability. This standard applies to the acquisition and product improvement of all designed or purchased (non-developmental items) systems, subsystems, equipment, and facilities that emit acoustic noise. This standard is intended to address noise levels emitted during the full range of typical operational conditions.

1.3 Purpose. This standard provides criteria for designing materiel having noise levels that:

- a. minimize noise induced hearing loss,
- b. permit acceptable speech communication in a noisy environment,
- c. minimize aural detection by an enemy,
- d. minimize community annoyance, and
- e. provide acceptable habitability of personnel quarters.

2. APPLICABLE DOCUMENTS

2.1 General. The documents listed in this section are specified in sections 3, 4, and 5 of this standard, including individual Requirements 1 - 7. This section does not include documents cited in other sections of this standard or recommended for additional information or as examples. While every effort has been made to ensure the completeness of this list, document users are cautioned that they must meet all specified requirements documents cited in sections 3, 4, and 5 of this standard, including individual requirements 1 - 7 whether or not they are listed.

2.2 Government documents.

2.2.1 Specifications, standards, and handbooks. The following specifications, standards, and handbooks form a part of this document to the extent specified herein. Unless otherwise specified, the issues of these documents are those listed in the issue of the Department of Defense Index of Specifications and Standards (DoDISS) and supplement thereto, cited in the solicitation (see 6.2).

SPECIFICATIONS

DEPARTMENT OF DEFENSE

MIL-P-15024	-	Plates, Tags, and Bands for Identification of Equipment
MIL-M-17185	-	Mounts, Resilient; General Specifications and Tests for (Shipboard Application)
MIL-M-17508	-	Mounts, Resilient: Types 6E100, 6E150, 7E450, 6E900, 6E2000, 5E3500, 6E100BB, 6E150BB, 7E450BB, and 6E900BB
MIL-M-19379	-	Mounts, Resilient, Mare Island Types 11M15, 11M25, and 10M50
MIL-M-19863	-	Mounts, Resilient: Type 5B5, 000H
MIL-M-21649	-	Mounts, Resilient, Type 5M10, 000H

MIL-STD-1474D

STANDARDS

DEPARTMENT OF DEFENSE

MIL-STD-1472 - Human Engineering

HANDBOOKS

DEPARTMENT OF DEFENSE

MIL-HDBK-1473 - Color and Color and Marking of Army Materiel
 MIL-HDBK-1908 - Definitions of Human Factors Terms

(Unless otherwise indicated, copies of federal and military specifications, standards, and handbooks are available from the Standardization Documents Order desk, 700 Robbins Avenue, Bldg 4D, Philadelphia, PA 19111-5094.)

2.2.2 Other Government documents, drawings, and publications. The following other Government documents, drawings, and publications form a part of this document to the extent specified herein. Unless otherwise specified, the issues are those cited in the solicitation.

29 CFR 1910.145 - Specification for Accident Prevention Signs and Tags
 40 CFR 204 - Noise Emission Standards for Construction

Equipment

(Copies of specifications, standards, and other publications required by contractors in connection with specific acquisition functions should be obtained from the contracting activity or as directed by the contracting officer.)

2.3 Non-Government publications. The following documents form a part of this document to the extent specified herein. Unless otherwise specified, the issues of the documents which are DoD adopted are those listed in the issue of the DoDISS cited in the solicitation. Unless otherwise specified, the issues of these documents not listed in the DoDISS are the issues of the documents cited in the solicitation (see 6.2).

AMERICAN NATIONAL STANDARDS INSTITUTE (ANSI)

ANSI S1.1 - Acoustical Terminology
 ANSI S1.2 - Physical Measurement of Sound, Method for
 ANSI S1.4 - Sound Level Meters, Specification for (DoD adopted)
 ANSI S1.6 - Preferred Frequencies and Band Numbers for Acoustical
 Measurements (DoD adopted)
 ANSI S1.10 - Calibration of Microphones, Method for the (DoD adopted)
 ANSI S1.11 - Octave-Band and Fractional-Octave-Band Analog and
 Digital Filters, Specification for (DoD adopted)
 ANSI S1.13 - Sound Pressure Levels, Method for the Measurement of
 (DoD adopted)
 ANSI S1.40 - Acoustical Calibrators, Specification for (DoD adopted)
 ANSI S3.5 - Articulation Index, Method for the Calculation of (DoD adopted)
 ANSI S6.1 - Qualifying a Sound Data Acquisition System, Recommended

Practice

(Requests for copies should be addressed to the American National Standards Institute, Inc., 1430 Broadway, New York, NY 10018.)

MIL-STD-1474D

SOCIETY OF AUTOMOTIVE ENGINEERS (SAE)

- SAE J88 - Sound Measurement - Earthmoving Machinery - Exterior (DoD adopted)
- SAE J184 - Qualifying a Sound Data Acquisition System (DoD adopted)
- SAE J366 - Exterior Sound Level for Heavy Trucks and Buses (DoD adopted)
- SAE J986 - Sound Level for Passenger Cars and Light Trucks (DoD adopted)
- SAE J1074 - Engine Sound Level Measurement Procedure (DoD adopted)

(Requests for copies should be addressed to the Society of Automotive Engineers, 400 Commonwealth Drive, Warrendale, PA 15096-0001.)

INTERNATIONAL ORGANIZATION FOR STANDARDIZATION (ISO)

- ISO R-226 - Normal Equal-Loudness Contours for Pure Tones and Normal Threshold of Hearing Under Free-Field Listening Conditions

(Requests for copies should be addressed to the American National Standards Institute, Inc., 1430 Broadway, New York, NY 10018.)

2.4 Order of precedence. In the event of a conflict between the text of this document and the references cited herein, the text of this document takes precedence. Nothing in this document, however, supersedes applicable laws and regulations unless a specific exemption has been obtained.

3. DEFINITIONS

Terms are defined in accordance with MIL-HDBK-1908. Terms not appearing in MIL-HDBK-1908 are defined in accordance with ANSI S1.1.

4. GENERAL REQUIREMENTS

4.1 Subsystems, sets, groups, and units.

4.1.1 Total system noise. Subsystems, sets, groups, and units including such items as air conditioners, heaters, input/output devices, printers, typewriters, and auxiliary equipment, shall be selected and integrated in such a manner that noise produced by the entire system does not exceed the requirements of this standard.

4.1.2 Government Furnished Equipment (GFE). The use of GFE shall not eliminate the requirement that the total system conform to this standard.

4.1.3 Engineering controls. Engineering controls shall be the primary means to protect personnel from hazardous noise. Hearing protectors and other measures such as warning signs shall not be solely relied upon unless all noise reduction design approaches have been pursued.

4.2 Noise hazard signs. Where Individual Requirements specify posting of noise hazard areas, signs should conform to 29 CFR 1910.145, and the Danger signs provisions in MIL-HDBK-1473, as applicable (see Figure 1). They shall be clearly visible and legible to all personnel exposed to the hazard. Generally, noise areas with levels above 100 dBA or 140 dBp should be posted with danger signs per Figure 1A. Areas with levels of 85 to 100 dBA should be posted with caution signs per Figure 1B.

MIL-STD-1474D

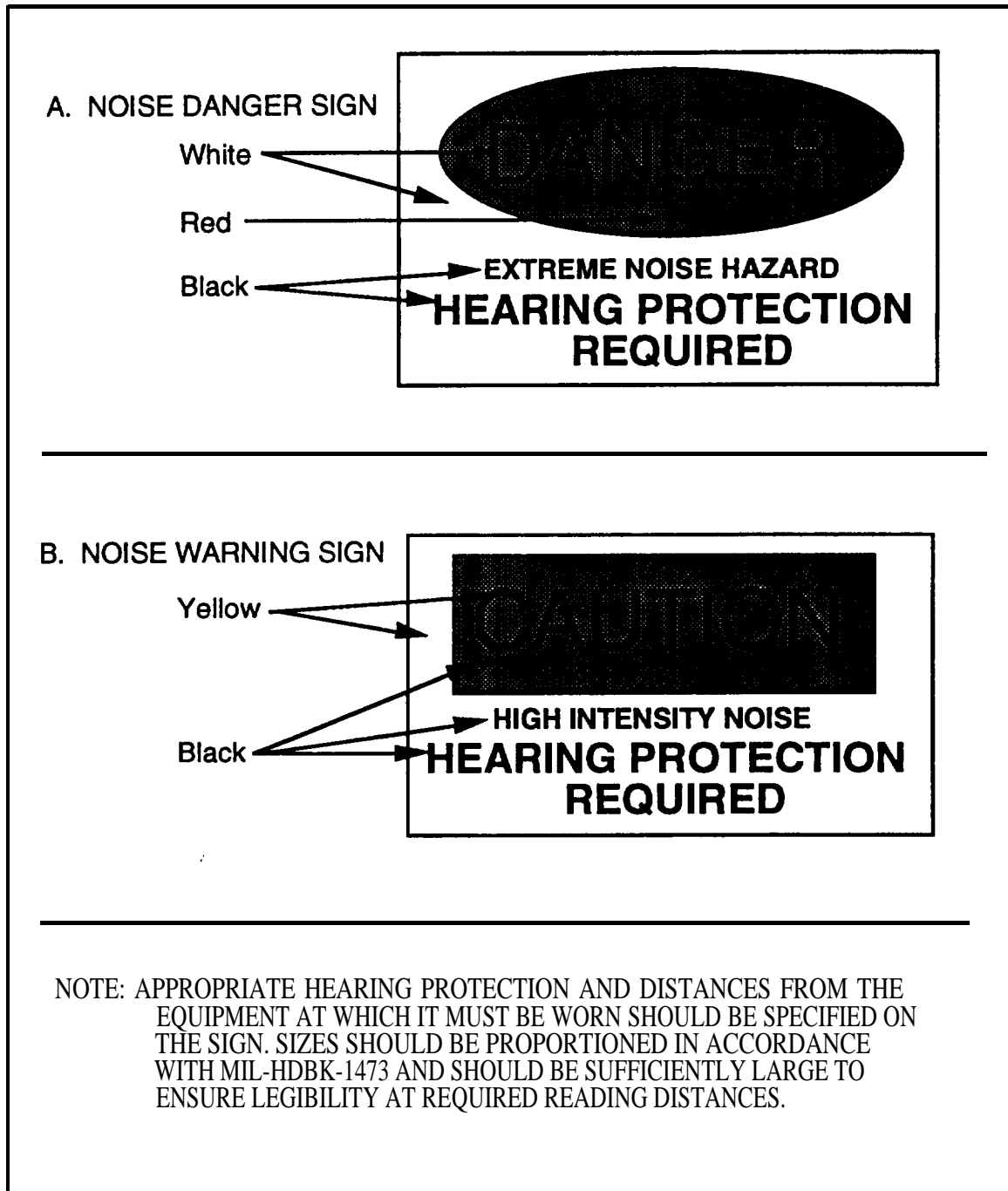

FIGURE 1. Noise hazard signs

MIL-STD-1474D

5. DETAILED REQUIREMENTS

5.1 Individual requirements. Individual Requirements follow Section 6. (Requirement 6 applies to all fixed wing aircraft. Requirement 6 also applies to rotary wing aircraft developed by the U.S. Air Force. Requirement 7 applies to rotary wing aircraft developed by the Army or Navy.)

5.2 Recording requirements. As a minimum, the following shall be recorded in addition to noise measurements made in accordance with the Individual Requirements.

5.2.1 Measurement instrumentation. Complete list of calibrated instrumentation (e.g. microphone, preamplifier, sound level meter, pistonphone, tape recorder, power supply, oscilloscope, frequency analyzer) used for measurements, including nomenclature, model, serial number, manufacturer, date of calibration, and period of calibration.

5.2.2 Equipment being measured. Complete identification of the equipment whose noise is being measured, including nomenclature, type, serial number, mileage (if appropriate), and any modifications to the equipment.

5.2.3 Operational conditions. Complete description of the operational conditions under which the test was conducted, such as speed (e.g., 2/3 maximum posted speed), rpm (e.g., rated engine rpm, 2/3 rated engine rpm), nominal muzzle velocity, load, transducer locations and orientation, weapon height, and weapon elevation.

5.2.4 Time and place. Date, time of day, and location of test.

5.2.5 Test site. Physical description of the area, including ground surface and reflecting surfaces (if appropriate), a sketch of contributing noise sources, normal personnel operating positions, microphone locations, orientation angles of the microphones with reference to the noise source, and the location of personnel present during the tests. Transducer locations for weapons shall be specified in polar coordinates with the origin being a point below the muzzle with the barrel or tube at 0 degrees elevation.

5.2.6 Atmospheric conditions. Air temperature, relative humidity, wind direction and speed, barometric pressure, cloud cover, and other atmospheric conditions.

5.2.7 Background noise. Background noise level, using the same bandwidth employed for the measurements of the noise source.

5.2.8 Calibration. Method and time of calibration.

5.2.9 Frequency analyzer bandwidth. Bandwidth of frequency analyzer (e.g., octave, one-third octave).

5.2.10 Time response. Time response of the measuring system (i.e., "slow" or "fast" or other appropriate description).

5.2.11 Microphone angles. Orientation angles of the microphones with reference to the noise source.

5.2.12 Tape recorder characteristics. Frequency response, control settings (including pre-emphasis, equalization, or other applicable equipment mode), and tape speed of tape recorder, if used.

MIL-STD-1474D

5.2.13 Test personnel. Name, address, and phone number of personnel making the noise measurements, and of personnel such as official witnesses and equipment operator(s).

5.2.14 Test data recording. See Figures 2 and 3 for a sample test data collection sheet and a blank data collection sheet, respectively. SI units (kPa) may be used with dB, μ bar, psi reported where appropriate.

6. NOTES

(This section contains information of a general or explanatory nature which may be helpful, but is not mandatory.)

6.1 Intended use. This standard is intended for use as a noise criteria design standard for design of military materiel, cited contractually in system specifications, and elsewhere, and for use as a basis for that part of noise testing where design characteristics are assessed for purposes of acceptance. It is not intended for use to express binding requirements in conceptual and other early acquisition phases. The standard may be applied to traditional, as well as non-developmental item (NDI) acquisitions.

6.2 Issue of DoDISS. When this standard is used in acquisition, the applicable issue of the DoDISS must be cited in the solicitation (see 2.2 and 2.3).

6.3 Associated Data Item Descriptions (DID)s. Specified under individual Requirements as applicable.

6.4 Supersession data. This revision supersedes the following standards:

MIL-STD-740-1	30 December 1986	Airborne Sound Measurements and Acceptance Criteria of Shipboard Equipment
MIL-STD-1294A	12 August 1985	Acoustical Noise Limits in Helicopters
MIL-STD-1474C(1)	30 July 1993	Noise Limits for Military Materiel
MIL-STD-1789A	13 May 1988	Sound Pressure Levels in Aircraft

MIL-STD-1474D

ACOUSTICAL TEST DATA																
TEST ITEM:		TRUCK: CARGO, 1 1/4 TON, 6x6, M561				DATE: 15 MAY 1990		TIME: 1400								
REG/MODEL NO: 03A 476 70		SERIAL NO: 2252511C		ODOMETER: 13,500		HOUR METER:		TEST CONDUCTED BY: D. R. SCRIBNER		TEST ITEM OPERATOR: ROBERT RUFF						
TEMPERATURE 27.4°C		HUMIDITY 63%		TEST SITE: PERRYMAN		SURFACE: PAVED		TERRAIN: LEVEL								
BAROMETRIC PRESSURE: 1012.2 mb		SKY COVER: SCATTERED		STATIONARY OPERATION <input type="checkbox"/>		HIGHWAY DRIVING <input checked="" type="checkbox"/>		DRIVE-BY								
WIND DIRECTION: S.S.W		WIND VELOCITY: 8 mp/h		MICROPHONE: B&K 4155		SOUND LEVEL METER		OCTAVE ANALYZER B&K 2131								
INTERIOR <input checked="" type="checkbox"/>		EXTERIOR <input type="checkbox"/>		MICROPHONE LOCATION: AS DESCRIBED BELOW		TAPE RECORDER: B&K 7006		TAPE NO: 1								
GEAR	RPM	APPROX SPEED	dBA	dBB	dBc	ALL PASS	31.5	63	125	250	500	1000	2000	4000	8000	REMARKS
1	1900	4 km/h		94	95	96	87	89	91	90	86	82	76	69		
2	1900	9 km/h	92	95	96	97	87	89	91	89	86	82	76	69		
3	1900	21 km/h	92	95	97	97	88	89	91	90	87	82	75	69		
4	4900	38 km/h	93	96	99	100	90	91	95	90	88	82	76	70		
Driver's ear position																
1	1900	4 km/h	89	92	94	95	86	88	92	88	84	81	75	68		
2	1900	9 km/h	90	92	94	95	86	87	93	87	85	81	75	68		
3	1900	21 km/h	90	93	95	97	86	88	93	90	86	82	75	68		
4	1900	38 km/h	92	95	97	98	87	90	95	90	87	82	77	69		
Passenger's ear position																
			85				106	96	89	83	80	79	79	81		
Maximum allowable limits for unprotected hearing (MIL-STD-1474, Category 'D')																

FIGURE 2. Sample form showing acoustical test data for M561 Cargo Truck

MIL-STD-1474D

ACOUSTICAL TEST DATA										TIME:		DATE:				
TEST ITEM:				TEST CONDUCTED BY:						TEST ITEM OPERATOR:						
REG/MODEL NO:		SERIAL NO:		ODOMETER:		HOUR METER:		TEST ITEM CONDITION:								
TEMPERATURE		HUMIDITY		TEST SITE:		SURFACE:		TERRAIN:								
BAROMETRIC PRESSURE:		SKY COVER:		STATIONARY OPERATION		HIGHWAY DRIVING		DRIVE-BY								
WIND DIRECTION:		WIND VELOCITY:		MICROPHONE:		SOUND LEVEL METER		OCTAVE ANALYZER								
INTERIOR <input type="checkbox"/>			EXTERIOR <input type="checkbox"/>			MICROPHONE LOCATION:					TAPE RECORDER:		TAPE NO:			
GEAR	RPM	APPROX SPEED	dBA	dBB	dBC	ALL PASS	31.5	63	125	250	500	1000	2000	4000	8000	REMARKS

FIGURE 3. Blank acoustical test data form

MIL-STD-1474D

6.5 Subject term (key word) listing.

Airborne equipment
Attenuating helmets or headsets
Aural nondetectability
Community annoyance
Hazards
Hearing conservation criteria
Hearing damage risk criteria
Hearing protectors
Impulse
Instrumentation
Peak pressure level
Personnel-occupied areas
Shipboard equipment
Speech interference level
Steady-state
Testing
Vehicles

6.6 Changes from previous issue. Marginal notations are not used in this revision to identify changes with respect to the previous issue due to the extensiveness of the changes.

6.7 Guidance Documents.

AFOSHSTD 48-19	-	Hazardous Noise Program
DA PAM 40-501	-	Hearing Conservation
29 CFR 1910.95	-	Occupational Noise Exposure
OPNAVINST 5100.23B	-	Navy Occupational Safety and Health Program Manual
OPNAVINST 5100.19B	-	Navy Occupational Safety and Health Program Manual for Forces Afloat

MIL-STD-1474D

This page intentionally left blank

MIL-STD-1474D

REQUIREMENT 1

STEADY-STATE NOISE, PERSONNEL OCCUPIED AREAS

1. Scope, applicability, and purpose. See Section 1 of the basic standard.

1.1 Scope. This Requirement establishes acoustical noise limits and prescribes testing requirements and measurement techniques for determining conformance to steady-state noise limits in personnel-occupied areas.

1.2 Applicability. This Requirement applies to the acquisition and product improvement of all designed, or purchased (non-developmental items) ground systems, subsystems, equipment, and facilities that emit acoustic noise. This requirement is intended to address noise levels emitted during the full range of typical operational conditions.

1.3 Purpose. This Requirement provides criteria for designing materiel having noise levels that minimize noise induced hearing loss and permit acceptable speech communication in a noisy environment.

2. Documents applicable to Requirement 1.

29 CFR 1910.145	Specification for Accident Prevention, Signs and Tags
40 CFR 204	Noise Emission Standards for Construction Equipment
MIL-STD-1472	Human Engineering
MIL-HDBK-1908	Definitions of Human Factors Terms
ANSI S1.1	Acoustical Terminology
ANSI S1.4	Sound Level Meters, Specification for (DoD adopted)
ANSI S1.10	Calibration of Microphones, Method for the (DoD adopted)
ANSI S1.11	Octave-Band and Fractional-Octave-Band Analog and Digital Filters, Specification for (DoD adopted)
ANSI S1.40	Acoustic Calibrators, Specification for (DoD adopted)
ISO R-226	Normal Equal-Loudness Contours for Pure Tones and Normal Threshold of Hearing Under Free-Field Listening Conditions

(The above documents are cited either in this Requirement or in Sections 3, 4, or 5 of the basic standard. For applicability and ordering information, see preambles and addresses in Section 2 of the basic standard.)

3. Definitions. Terms are defined in accordance with MIL-HDBK-1908. Terms not appearing in MIL-HDBK-1908 are defined in accordance with ANSI S1.1.

4. General Requirements.

4.1 Subsystems, sets, groups, and units. See Section 4.1 of the basic standard.

4.2 Posting of noise hazard areas. If steady-state noise levels are 85 dBA or greater, at locations specified in 5.2.1.2, noise hazard caution signs shall be permanently posted on (or in) the equipment. This provision shall not apply to the exteriors of military combat equipment. Signs shall conform to 4.2 of the basic standard. This posting is required regardless of exposure time or duty cycle acceptance (see 5.2.1.7). Where operating or maintenance conditions seldom exceed 85 dBA, posting may be unnecessary.

MIL-STD-1474D

4.3 Manuals. Where steady-state noise is 85 dBA or greater at personnel-occupied areas (e.g., operator, maintenance, observer, and other control positions), operation and maintenance manuals (e.g., field and technical manuals) shall contain appropriate discussion of noise hazards. Discussion shall include the requirement for hearing protection, the type of hearing protection recommended, the noise level of the equipment at locations specified in 5.2.1.2, and the distance at which the 85 dBA limit will be met.

4.4 Pulsating equipment. Pulsating equipment (e.g., jack hammers, air tools, impact wrenches) which may be operated for periods of time in excess of one second and where peak level is less than 140 dBp, shall comply with the steady-state noise provisions herein.

5. Detailed requirements.

5.1 Noise limits.

5.1.1 Categories. Table 1-I is provided to guide procurement activity decision in selecting a noise limit category. The corresponding noise limits are shown in Table 1-II. If the total system configuration is unknown, the allowable noise limit for any single item shall be 3 dB below the limit of the applicable system category.

TABLE 1-I. Steady-state noise categories

Category ¹	System Requirements
A	No direct person-to-person voice communication required. Maximum design limit. Hearing protection required.
B	Electrically-aided communication via attenuating helmet or headset required. Noise levels are hazardous to unprotected ears.
C	No frequent direct person-to-person voice communication required. Occasional shouted communication may be possible at a distance of 30 cm. Hearing protection required.
D	No frequent person-to-person voice communication required. Occasional shouted communication may be possible at a distance of 60 cm. Levels in excess of Category D require hearing protection.
E	Occasional telephone or radio use or occasional communication at distances up to 1.50 m required. (Equivalent to NC-70)
F	Frequent telephone or radio use or frequent communication at distances up to 1.50 m required. (Equivalent to NC-60).

¹Categories A, B, C, and D are based primarily on hearing conservation priorities; the remaining categories are based primarily on communication requirements. For fixed-plant facilities, see MIL-STD-1472

MIL-STD-1474D

TABLE 1-II. Steady-state noise limits (dBA) for personnel-occupied areas

Limit Category:	A ¹	B ¹	C ¹	D ¹	E ²	F ²
A-Weighted Limit (dBA):	108	100	90	<85	75	65
SIL-4 Limit:					67	57

¹These limits are based on a maximum daily exposure time of 8 hours. In those cases where the mission profile for the equipment being developed or acquired exceeds 8 hours of operation in each 24-hour day, the limits specified in Categories A, B, C, and D shall be reduced to allow for an exposure of longer than 8 hours, as approved by the procuring activity in conjunction with the appropriate military Surgeon General's Office.

²Categories E and F are defined by either the sound level (dBA) or the speech interference level (SIL-4). If meeting the dBA requirement has been documented to be infeasible (see 5.1.3.2), then this requirement shall be replaced with the corresponding SIL-4 limit.

5.1.2 Maximum.

a. For systems requiring person-to-person communication, Category E or F shall be selected on the basis of Table 1-I.

b. All other systems shall not exceed Category D.

c. Where the limit of Category D can be documented as being clearly beyond the state-of-the-art per 5.1.3.2, selection of another noise limit shall be made by the procuring activity on the basis of system requirements.

5.1.3 Acceptance.

5.1.3.1 Compliance. Compliance with the required noise limit shall be documented based upon test requirements of 5.2 and the data recording requirements of 5.3.

5.1.3.2 Non-compliance. Non-compliance with the required noise limit shall be documented based upon test requirements of 5.2 and the data recording requirements of 5.3; additionally, the following shall apply:

a. The required maximum noise limit(s) may be established to be technically infeasible based upon testing and analysis consistent with best engineering practice, which clearly proves that achievement of the required limit(s) is beyond the state-of-the-art for the item/system being procured. Such testing and the resultant analysis shall be conducted and reported by a professionally qualified acoustical consultant or acoustical laboratory. Documentation shall be furnished to the procuring activity for consideration of whether or not increase of the required limit(s) is justified.

b. Documentation shall contain technically defensible data including technically supported design considerations, technically supported design recommendations for noise reduction, and technically supported predictions of the resultant noise levels.

MIL-STD-1474D

c. Noise reduction feasibility documentation shall also include the following:

(1) Identification of all the noise sources that contribute to the noise level at the locations of interest.

(2) Identification of all noise paths between the noise sources and the locations of interest.

(3) Rank ordering of the source/path combinations in terms of their contribution to the overall level at the locations of interest.

(4) Development of noise control measures for each source/path combination in order of dominance until the required noise levels at the locations of interest are attained.

(5) Clearly stated and technically/fiscally supported trade-off analyses of noise control benefit against other design and performance requirements, consistent with best engineering practice.

(6) An experimental procedure known as "window analysis" shall be used in steps (1) through (5). The procedure involves measuring the noise level while eliminating all noise sources and paths except the single one of interest. For example, one type of engine noise source determination could be made by running the engine under load with and without the engine fan being driven.

(7) The window analysis procedure shall be repeated for each of the combinations identified (see (1) to (3) above).

d. Only if the maximum noise limit(s) required has been documented as being clearly beyond the state-of-the-art, may the procuring activity expressly grant written permission to exceed the specified limit(s). Any decision to grant permission to exceed the specified limits shall consider health hazard assessments and the operational impact of the hazards associated with exceeding the limits.

5.2 Test requirements.

5.2.1 General.

5.2.1.1 Acceptance criteria. Noise at locations designated by 5.2.1.2 shall meet the specified limit.

5.2.1.2 Measurement location. Noise measurements shall be made at:

- a. each operator or crew position.
- b. representative positions where one or more individuals (e.g., passengers) will be located, and
- c. occasionally occupied positions during typical operation or maintenance of the item/system (e.g., the space in and around a generator set, pump, or arc welder).

NOTE: Where the operator, crew, or passenger station(s) is not clearly defined or where unattended use of equipment is intended (e.g., some mobile electric power, pumps, etc.), the noise measurement position(s) shall be designated by the procuring activity.

MIL-STD-1474D

5.2.1.3 Recording. The data recorded and reported shall include A-weighted, C-weighted, and octave-band sound pressure levels, and, when appropriate, speech interference levels.

5.2.1.4 Noise contours. Where the steady-state noise level of stationary equipment is 85 dBA or greater, the distances and directions from the noise source at which the sound level equals 85 dBA shall be determined. The 85 dBA contours shall also be determined for mobile equipment which could, at times, be stationary. The 85 dBA contour shall be determined from measurements made at positions around the noise source at angular increments not greater than 45 degrees, and at the noisiest angle. The maximum distance at which 85 dBA is obtained shall be indicated on the noise hazard sign in 4.2 of the basic standard.

5.2.1.5 Equipment openings. All windows, vents, and access openings shall be in the normal operation position as defined by the procuring activity. If it is possible to operate with these in either the open or closed positions, both configurations shall be tested.

5.2.1.6 Test schedule. During development, sound level measurements shall be made, as a minimum, when the test item is first undergoing testing. Measurement of the final system configuration shall be made as early as possible before first article acceptance.

5.2.1.7 Typical duty cycle testing. If typical duty cycle testing is specified by the procuring activity, the time-weighted average level (L_{avg}) shall be determined. Duty cycles shall be as short as practical and the noise exposure of sufficient cycles shall be measured for a minimum duration of 1 hour at rated capacity. When the L_{avg} does not change over ± 2.0 dBA from cycle to cycle, one cycle shall be adequate. The equipment shall be operated at a test site typical of the environment in which the equipment is to be used, as specified by the procuring activity.

5.2.1.8 Sample size. Materiel acceptance shall be based on an adequate test sample to be determined by the procuring activity.

5.2.2 Operating conditions for system testing. Systems shall be operated as required to accomplish their intended missions or functions. All subsystems and auxiliary equipment normally in use shall be operated. Heaters and air conditioners shall be operated in accordance with 5.2.3.1.3.

5.2.3 Operating conditions for mobile equipment testing.

5.2.3.1 Vehicles.

5.2.3.1.1 Vehicle speed and gear. Vehicle noise shall be measured at two-thirds of rated engine speed (not maximum governed speed) or two-thirds of the vehicle speed posted in the vehicle, in the highest gear or in the drive mode if the transmission is automatic, or as specified by the procuring activity (for compliance). The vehicle shall have engine speed or vehicle speed measured by a calibrated tachometer or speedometer, as appropriate. Measurements shall also be made at either 8 or 16 km/h increments up to the maximum vehicle speed. If 16 km/h increments are selected, measurements shall start at 16 rather than 8 km/h.

5.2.3.1.2 Load-carrying equipment. All load-carrying equipment shall be operated with two-thirds of maximum payload or as specified by the procuring activity (for compliance). Vehicles (including tractor/trailer combinations) shall be operated at two-thirds of the off-highway payload. Auxiliary trailed equipment shall not be towed during the test. Vehicles shall also be tested at the maximum payload including towed trailers at maximum payload where applicable to the vehicle design.

MIL-STD-1474D

5.2.3.1.3 Auxiliary equipment. All auxiliary equipment normally in continuous use while the vehicle is in motion shall be operated; however, where heaters and air conditioners may be used at the same time (such as humidity control) both shall be operated. Where both heaters and air conditioners are present, the one producing the higher sound level shall be operated.

5.2.3.1.4 Selection criteria. Where applicable, tests shall be made on new equipment after the officially prescribed break-in time or mileage, and after performance requirements have been met.

5.2.3.2 Construction and materials-handling equipment. The procuring activity shall specify a repeatable, steady operating condition that produces about the same noise as a typical duty cycle. The duty cycle will consider speed, load, and test surface.

5.2.3.3 Watercraft. Watercraft noise shall be measured under normal cruise/calm water conditions or as specified by the procuring activity.

5.2.4 Operating conditions for stationary equipment testing.

5.2.4.1 Speed. All equipment shall be operated at maximum-rated continuous duty speed or as specified by the procuring activity.

5.2.4.2 Load. All equipment shall be operated at normal maximum-rated load. The exception is that variable-speed equipment, which is normally operated at less than maximum, shall be operated at two-thirds maximum-rated load or as specified by the procuring activity.

5.2.4.3 Auxiliary equipment. All auxiliary equipment normally in use shall be operated. Heaters and air conditioners shall be operated in accordance with 5.2.3.1.3.

5.2.5 Test environment, instrumentation, and measurements.

5.2.5.1 Test environment.

5.2.5.1.1 Test site. Equipment shall be tested in its exact operating location if the location is known and such testing is feasible. When this is not possible, the test site shall be a uniform flat grass surface, free of ice, snow, or vegetation over 15 cm tall; it shall be free of reflecting surfaces such as buildings, trees, or hillsides within 30 m. An anechoic or hemi-anechoic chamber may be substituted for outdoor measurements.

5.2.5.1.2 Background noise. When practical, background noise, including wind noise, shall be at least 10 dB below that of the equipment noise being measured; however, background noise shall always be at least 10 dB below the criteria. A windscreen shall be used at wind velocities of 10 km/h or more; measurements shall not be made at velocities of 20 km/h or more.

5.2.5.1.3 Surface and grade for vehicle testing. Vehicles shall be driven along a dry, smooth, paved, and level road (<1% grade), free from gravel or other loose material. Vehicles having nonrubber-padded tracks shall be driven on level, compact earth or as specified by the procuring activity. Measurements shall not be made when the road surface is wet, covered with snow or ice, or during precipitation, unless specified by the procuring activity.

5.2.5.2 Instrumentation.

5.2.5.2.1 Instrument specifications. Sound level meters shall conform to requirements for Type 1, as specified by ANSI S1.4. Band filter sets shall conform to requirements for Order 3, Type 3-D, Extended Range, as specified by ANSI S1.11. Other noise recording instrumentation or combinations of instrumentation shall conform to SAE J184 and applicable provisions of ANSI S1.4.

MIL-STD-1474D

5.2.5.2.2 Calibration. Acoustical calibration procedures shall be accomplished in accordance with the sound level meter manufacturer's instructions (see also ANSI S1.10). Calibrators shall conform to ANSI S1.40 Calibration shall address the influence of microphones, cables, amplifiers and recorders. Calibration shall be performed any time instrumentation is changed, before and after each test sequence, but not less than at the start and end of each day.

5.2.5.2.3 Microphones. Pressure microphones having an essentially flat response at grazing incidence (90 degrees) should be used, but free field microphones having an essentially flat response at normal incidence (0 degrees) may be used with the addition of a random incidence corrector. The microphone shall ordinarily be placed vertically at the measurement location with the sensitive element up. However, for exterior measurements of stationary test items (at distances greater than three times the major dimension of the test item), a normal incidence microphone without a random incidence corrector may be used if it is pointed at the item.

5.2.5.3 Measurement. Data collection shall include on-site, unweighted octave-band and A-, and C-weighted measurements. Slow meter damping shall be used. Tape recording may be used in place of, or in addition to, the above. For those exceptions where the noise level is determined under a typical duty cycle, measurements shall be made with an integrating sound level meter or other recording instruments that measure time weighted average level (L_{avg}) as defined in MIL-HDBK-1908. L_{avg} shall be measured using the time-sound level exchange rate appropriate for the Service involved.

5.2.5.3.1 Personnel limits and locations during tests.

5.2.5.3.1.1 Operator(s). During testing, the operator(s) shall not occupy that location where the noise is being measured unless required to operate the equipment.

5.2.5.3.1.2 No operator present. When no operator is present, the measurement shall be made at the center of the operator's probable head location. For standing locations the microphone shall be 1.60 m above the floor, for sitting locations it shall be 0.80 m above the seat which, if adjustable, shall be positioned at the center of its vertical adjustment range.

5.2.5.3.1.3 Operator present. When the operator must be present, the measurement shall be made at ear level, 15 cm from the right ear. If a wall or other reflective surface is closer than 3 cm from the operator's right ear, the microphone shall be positioned equidistant from the right ear and that surface.

5.2.5.3.1.4 Test personnel. Noise measurements shall be made with the minimum number of people in the area, including test personnel. When noise is being measured in personnel-occupied enclosures, no test personnel or observers shall be present within the enclosure unless required to operate or adjust the test equipment, or to record data.

5.3 Data recording. See 5.2 of basic standard.

6. Notes.

6.1 Intended use. This Requirement is intended for use as a steady-state noise criteria design standard for military ground materiel, cited contractually in system specifications, and elsewhere, and for use as a basis for that part of noise testing where design characteristics are assessed for purposes of acceptance. It is not intended for use to express binding requirements in conceptual and other early acquisition phases. The Requirement may be applied to traditional, as

MIL-STD-1474D

well as non-developmental item (NDI) acquisitions. This Requirement is not intended for applicability to shipboard equipment or aircraft noise (specified by Requirements 5, 6, or 7, as applicable.)

6.2 Associated Data-Item-Description (DID). This standard is cited in DoD 5010.123L, Acquisition Management Systems and Data Requirements Control List (AMSDL), as the source document for the following DID. When it is necessary to obtain the data the applicable DID must be listed on the Contract Data Requirements List (DD Form 1423) except where the DoD Federal Acquisition Regulation Supplement exempts the requirement for a DD Form 1423.

<u>DID Number</u>	<u>DID Title</u>
DI-HFAC-80938A	Noise Measurement Report

The above DID was current as of the date of this Requirement. The current issue of the AMSDL must be researched to ensure that only the current and approved DID is cited on the DD Form 1423.

6.3 Details specified by the procuring activity. Applicable details, such as the following, should be specified by the procuring activity in the request for proposal (RFP) and in appropriate follow-up requirements documentation.

6.3.1 Hearing protection. When it is known that certain types of hearing protection will interfere with the use of helmets or other equipment.

6.3.2 Operating conditions for testing.

a. Whether typical duty cycle testing is specified for the item (see 5.2.1.7).

NOTE: Where the procuring activity has determined that the noise tests at the constant operating conditions stated herein are clearly inappropriate or non-representative, another constant operating condition(s) may be specified by the procuring activity. Where it is not possible to establish any appropriate constant operating condition for the noise test, the equivalent continuous sound level shall be determined under a typical duty cycle to be specified by the procuring activity.

b. Vehicle engine speed and gear, load and test surface, if different from the Requirement (see 5.2.3.1.1, 5.2.3.1.2, and 5.2.5.1.3).

c. Off-road construction and materials-handling equipment speed, load, and test surface (see 5.2.3.2).

d. Watercraft speed and load, if different from the Requirement (see 5.2.3.3).

e. Stationary equipment speed and load, if different from the Requirement (see 5.2.4.1 and 5.2.4.2).

6.3.3 Measurement locations when not clearly defined. (See 5.2.1.2.)

6.3.4 Sample size. (See 5.2.1.8)

MIL-STD-1474D

6.4 Information to the development test agency. Developing agencies should make appropriate information available to the development test agency, as required, to ensure that test conditions, noise category selection, and evaluation of results are consistent with system requirements, specified hearing protection requirements, if any, and general procuring activity-specified requirements relevant to the provisions of this Requirement.

MIL-STD-1474D

REQUIREMENT 2

AURAL NONDETECTABILITY

1. Scope, applicability, and purpose.

1.1 Scope. This Requirement establishes acoustical noise limits and prescribes testing requirements and measurement techniques for determining conformance to aural nondetectability requirements.

1.2 Applicability. This Requirement applies to the acquisition and product improvement of all designed, or purchased (non-developmental items) ground systems, subsystems, equipment, and facilities that emit acoustic noise. This requirement is intended to address noise levels emitted during the full range of typical operational conditions.

1.3 Purpose. This Requirement provides criteria for designing materiel having noise levels that minimize aural detection by an enemy.

2. Documents applicable to Requirement 2:

MIL-HDBK-1908	Definitions of Human Factors Terms
ANSI S1.1	Acoustical Terminology
ANSI S1.4	Sound Level Meters, Specification for (DoD adopted)
ANSI S1.10	Calibration of Microphones, Method for the (DoD adopted)
ANSI S1.11	Octave-Band and Fractional-Octave-Band Analog and Digital Filters, Specification for (DoD adopted)
ANSI S1.40	Acoustic Calibrators, Specification for (DoD adopted)
SAE J184	Qualifying a Sound Data Acquisition System

(The above documents are cited either in this Requirement or in Sections 3, 4, or 5 of the basic standard. For applicability and ordering information, see preambles and addresses, respectively, in Section 2 of the basic standard.)

3. Definitions. Terms are defined in accordance with MIL-HDBK-1908. Terms not appearing in MIL-HDBK-1908 are defined in accordance with ANSI S1.1.

4. General Requirements. See Section 4 of the basic standard.

5. Detailed Requirements.5.1 Noise limits.

5.1.1 Criteria. Equipment having an aural nondetectability requirement shall not exceed the limits of Tables 2-I or 2-II, as specified by the procuring activity. These tables provide two categories of limits (Level I and Level II). Selection is based upon the anticipated use of the equipment and the criticality of aural nondetectability, as follows:

5.1.1.1 Level I. Aural nondetectability limits (Table 2-I) assume that the listener is in a quiet rural area (Table 2-III) with the closest heavily used highway and community noise sources further than 4 km away. This limit will provide aural nondetectability under many, but not all, conditions of wind, temperature, terrain, and time of day.

MIL-STD-1474D

TABLE 2-I. Level I aural nondetectability limits (dB)

1/3 Octave Band Frequency (Hz)	Nondetectability Distance (m)																
	10	20	30	100	200	300	400	500	750	1000	1250	1500	2000	3000	4000	5000	6000
50	53	59	62	61	68	71	74	66	70	73	75	76	79	84	87	90	92
63	50	52	56	59	65	69	71	64	68	71	73	75	78	83	87	91	94
80	49	45	58	60	66	69	72	65	69	72	75	77	81	87	93	97	101
100	46	41	56	59	65	69	72	65	70	73	77	79	84	92	99	104	107
125	41	35	51	58	64	69	72	65	71	76	79	83	89	98	102	105	106
160	39	33	48	55	63	68	72	66	73	79	84	88	93	97	101	101	102
200	42	37	51	52	61	67	72	68	78	82	85	87	89	92	94	96	97
250	44	40	53	50	61	69	76	71	76	79	80	81	83	86	89	91	93
315	46	41	54	50	63	71	75	68	71	73	74	75	77	81	83	86	88
400	43	37	50	51	62	66	68	62	64	66	67	69	71	75	78	81	84
500	42	40	54	54	61	64	66	55	58	60	61	63	65	70	73	77	80
630	37	38	54	55	63	67	68	53	56	58	60	61	64	69	74	78	82
800	31	31	47	54	63	66	68	54	57	59	61	63	66	72	77	82	87
1000	29	27	42	50	59	63	65	54	57	60	62	64	68	74	80	86	91
1250	31	24	39	42	52	57	59	54	57	60	62	65	69	76	83	90	96
1600	31	23	35	36	46	51	54	52	56	59	62	64	69	78	87	95	NA
2000	25	23	32	36	47	52	55	50	54	58	62	65	71	82	92	97	NA
2500	26	28	31	28	39	44	48	46	52	56	60	64	72	86	NA	NA	NA
3150	21	19	34	29	40	46	50	40	47	53	59	64	74	94	NA	NA	NA
4000	21	18	34	25	37	44	49	39	48	56	64	71	86	NA	NA	NA	NA
5000	18	21	25	23	35	43	50	48	60	71	82	93	NA	NA	NA	NA	NA
6300	20	25	30	27	40	50	58	56	73	89	NA	NA	NA	NA	NA	NA	NA
8000	30	35	39	40	54	67	78	79	NA	NA	NA	NA	NA	NA	NA	NA	NA
10000	31	37	42	47	64	81	96	NA	NA	NA	NA	NA	NA	NA	NA	NA	NA
Measurement Distance (m)	2	2	2	10	10	10	10	30	30	30	30	30	30	30	30	30	30

MIL-STD-1474D

TABLE 2-II. Level II aural nondetectability limits (dB)

1/3 Octave Band Frequency (Hz)	Nondetectability Distance (m)																
	10	20	30	100	200	300	400	500	750	1000	1250	1500	2000	3000	4000	5000	6000
50	53	59	62	61	68	71	74	66	70	73	75	76	79	84	87	90	92
63	46	52	56	55	61	65	68	60	64	67	69	71	74	79	83	87	90
80	39	45	49	50	56	60	62	55	59	62	65	67	71	78	83	87	91
100	35	41	44	48	54	58	61	54	58	62	65	68	73	81	87	93	95
125	29	35	38	45	52	56	60	53	59	63	67	71	77	86	90	92	94
160	27	33	37	44	51	56	60	55	62	68	73	77	81	85	90	90	91
200	32	37	41	42	51	57	62	58	77	72	75	76	79	82	84	86	87
250	35	40	44	41	52	60	66	62	67	69	71	72	74	77	80	82	83
315	37	41	46	42	55	63	66	60	63	64	66	67	69	72	75	78	80
400	34	37	41	42	53	57	59	53	55	57	59	60	62	66	69	72	75
500	33	40	45	45	52	55	57	46	49	50	52	54	56	60	64	68	71
630	27	38	44	45	53	57	58	43	46	48	50	51	44	59	64	68	72
800	21	31	37	44	53	56	58	44	47	49	51	53	56	62	67	72	77
1000	19	27	32	40	49	53	55	44	47	50	52	54	58	64	70	76	81
1250	21	24	29	32	42	47	49	44	47	50	52	55	59	66	73	80	86
1600	22	23	26	27	37	42	45	43	47	50	53	55	60	69	78	86	94
2000	16	23	23	27	38	43	46	41	45	49	53	56	62	73	83	94	NA
2500	18	28	23	20	31	36	40	38	44	48	52	56	64	78	92	NA	NA
3150	13	19	26	21	32	38	42	32	39	45	51	56	66	86	NA	NA	NA
4000	14	18	27	18	30	37	42	32	41	49	57	64	79	NA	NA	NA	NA
5000	13	21	20	18	30	38	44	43	55	66	77	87	NA	NA	NA	NA	NA
6300	20	25	30	27	40	50	58	56	73	89	NA	NA	NA	NA	NA	NA	NA
8000	30	35	39	40	54	67	78	79	NA	NA	NA	NA	NA	NA	NA	NA	NA
10000	31	37	42	47	64	81	96	NA	NA	NA	NA	NA	NA	NA	NA	NA	NA
Measurement Distance (m)	2	2	2	10	10	10	10	30	30	30	30	30	30	30	30	30	30

MIL-STD-1474D

TABLE 2-III. Frequency (Hz) and accompanying 1/3 octave band ambient noise levels (dB) for both Level I and Level II categories

<u>Frequency (Hz)</u>	<u>Level I - Rural Area Ambient Noise Level (dB)</u>	<u>Level II - Quietest Area Ambient Noise Level (dB)</u>
50	34	29
63-----	37-----	29
80	38	28
100	38	26
125-----	37-----	24
160	34	23
200	31	21
250-----	28-----	19
315	26	18
400	25	16
500-----	24-----	15
630	24	14
800	23	13
1000-----	22-----	12
1250	21	11
1600	19	10
2000-----	18-----	9
2500	16	8
3150	15	7
4000-----	14-----	7
5000	12	6
6300	10	6
8000-----	9-----	6
10000	8	6

MIL-STD-1474D

5.1.1.2 Level II. Aural nondetectability limits (Table 2-II) assume that the listener is in the quietest background noise level (Table 2-III) that is likely to be encountered in practice with the closest heavily used highway and community noise sources further than 10 km away. This limit will provide aural nondetectability under most conditions of wind, temperature, terrain, and time of day.

5.1.2 Maximum. Equipment noise shall not exceed the specified noise limit for the selected nondetectability distance at the indicated measurement distance. The limit shall be satisfied if it is not exceeded in any band at any azimuth around the equipment. (NOTE: The requirements presented in Tables 2-I and 2-II are shown in graphical form (Figures 2-1 thru 2-6). The graphs can be used to plot the measured system/item noise level directly on the figure, thereby determining the frequency that produces detectability, the number of decibels by which the limit is exceeded, and an approximation of the actual nondetectability distance of the materiel.)

5.2. Test requirements.

5.2.1 Test site. Equipment shall be tested in its exact operating location if the location is known and such testing is feasible. When this is not possible, the test site shall be a uniform flat grass surface, free of ice, snow, or vegetation over 15 cm tall; it shall be free of reflecting surfaces such as buildings, trees, or hillsides within 30 m. An anechoic or hemi-anechoic chamber may be substituted for outdoor measurements.

5.2.2 Equipment operating conditions. Equipment operating conditions will depend upon the conditions for which nondetectability is required and shall be specified by the procuring activity.

5.2.3 Microphone location. The microphone shall be positioned 1.2 m above the ground, at the indicated measurement distance. (NOTE: The noise of an item should, whenever possible, be measured at a distance of at least four times the major dimension of the source. Measurements made at this distance follow the inverse square law (6 dB decrease for each doubling of distance) with the resulting measurements being appropriate for predicting nondetectability.)

5.2.4 Instrumentation. Instrumentation shall conform to the following, as applicable.

5.2.4.1 Instrument specifications. Sound level meters shall conform to requirements for Type 1, as specified by ANSI S1.4. Band filter sets shall conform to requirements for Order 3, Type 3-D, Extended Range, as specified by ANSI S1.11. Other noise recording instrumentation or combinations of instrumentation shall conform to SAE J184 and applicable provisions of ANSI S1.4.

5.2.4.2 Calibration. Acoustical calibration procedures shall be accomplished in accordance with the sound level meter manufacturer's instructions (see also ANSI S1.10). Calibrators shall conform to ANSI S1.40. Calibration shall address the influence of microphones, cables, amplifiers and recorders. Calibration shall be performed any time instrumentation is changed, before and after each test sequence, but not less than at the start and end of each day.

5.2.4.3 Microphones. Pressure microphones having an essentially flat response at grazing incidence (90 degrees) should be used, but free field microphones having an essentially flat response at normal incidence (0 degrees) may be used with the addition of a random incidence corrector. The microphone should ordinarily be placed vertically at the measurement location with the sensitive element up. However, for exterior measurements of stationary test items (at distances greater than three times the major dimension of the test item), a normal incidence microphone without a random incidence corrector may be used if it is pointed at the item.

5.2.5 Measurements. Reported measurement values shall be the maximum deflection using the fast exponential-time-averaging characteristics (125-ms time constant) of a sound level meter, or equivalent.

MIL-STD-1474D

5.2.6 Environment.

5.2.6.1 Background noise. When practical, background noise, including wind noise, shall be at least 10 dB below that of the equipment noise being measured. However, background noise shall always be at least 10 dB below the criteria, with the exception that use of conventional background noise corrections is permitted in accordance with ANSI S1.13. A windscreen shall be used at wind velocities of 10 km/h or more; measurements shall not be made at velocities of 20 km/h or more.

5.2.6.2 Surface and grade for vehicle testing. Vehicles shall be driven along a dry, smooth, paved, and level road (<1% grade), free from gravel or other loose material. Vehicles having nonrubber-padded tracks shall be driven on level, compact earth or as specified by the procuring activity. Measurements shall not be made when the road surface is wet, covered with snow or ice, or during precipitation, unless specified by the procuring activity.

5.2.7 Personnel limits and locations during tests.

5.2.7.1 Operator(s). During testing, the operator(s) shall not occupy that location where the noise is being measured unless required to operate the equipment.

5.2.7.2 Test personnel. Noise measurements shall be made with the minimum number of people in the area, including test personnel. When noise is being measured in personnel-occupied enclosures, no test personnel or observers shall be present within the enclosure unless required to operate or adjust the test equipment, or to record data.

5.3 Data recording. See 5.2 of basic standard.6. Notes.

6.1 Intended use. This Requirement is intended for use as an aural non-detectability design standard for military ground materiel, cited contractually in system specifications, and elsewhere, and for use as a basis for that part of noise testing where design characteristics are assessed for purposes of acceptance. It is not intended for use to express binding requirements in conceptual and other early acquisition phases. The Requirement may be applied to traditional, as well as non-developmental item (NDI) acquisitions.

6.2 Associated Data Item Description (DID). This standard is cited in DoD 5010.12L, Acquisition Management Systems and Data Requirements Control List (AMSDDL), as the source document for the following DID. When it is necessary to obtain the data, the DID must be listed on the Contract Data Requirements List (DD Form 1423) except where the DoD Federal Acquisition Regulation Supplement exempts the requirement for a DD Form 1423.

<u>DID Number</u>	<u>DID Title</u>
DI-HFAC-80938B	Noise Measurement Report

The above DID was current as of the date of this Requirement. The current issue of the AMSDDL must be researched to ensure that only the current and approved DID is cited on the DD Form 1423.

6.3 Details specified by the procuring activity. Applicable details, such as the following, should be specified by the procuring activity in the request for proposal (RFP) and in appropriate follow-up requirements documentation.

- a. Limit category (see 5.1.1).

MIL-STD-1474D

- b. Test site conditions other than those specified by the Requirement, if required (see 5.2.1).
- c. Equipment operating conditions for test (see 5.2.2).
- d. Non-rubber padded tracked vehicle testing surface if different from the requirement (see 5.2.6.2).
- e. Use of wet, snow-covered, or ice-covered test surfaces if required (see 5.2.6.2).

6.4 Information to the development test agency. Developing agencies should make appropriate information available to the development test agency, as required, to ensure that test conditions, noise category selection, and evaluation of results are consistent with system requirements, specified hearing protection requirements, if any, and general procuring activity-specified requirements relevant to the provisions of this Requirement.

MIL-STD-1474D

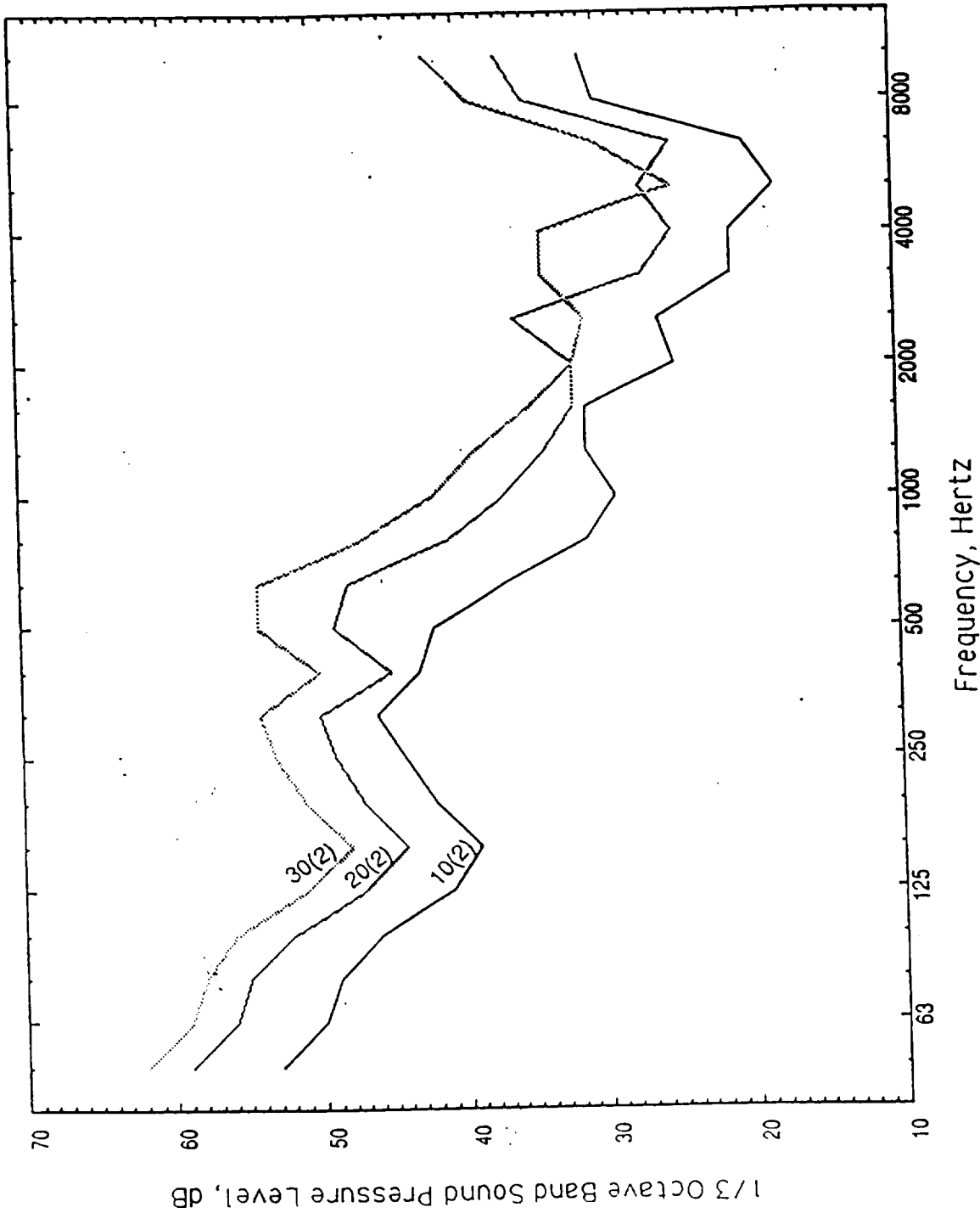

Note: The number in parentheses is the measurement distance in meters

FIGURE 2-1. Level I nondetectability limits for 10 - 30 meters

MIL-STD-1474D

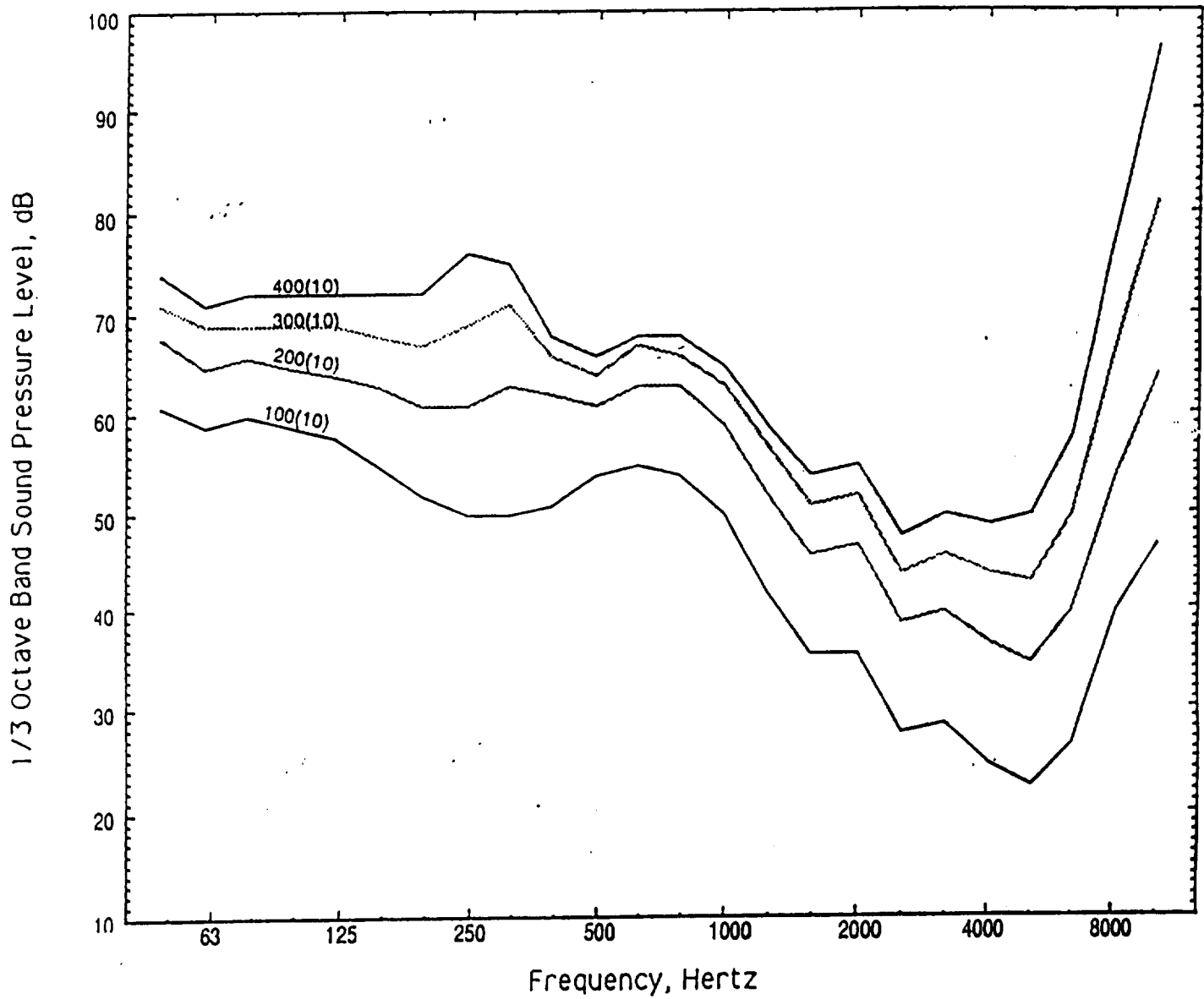

Note The number in parentheses is the measurement distance in meters

FIGURE 2-2. Level I nondetectability limits for 100 - 400 meters

MIL-STD-1474D

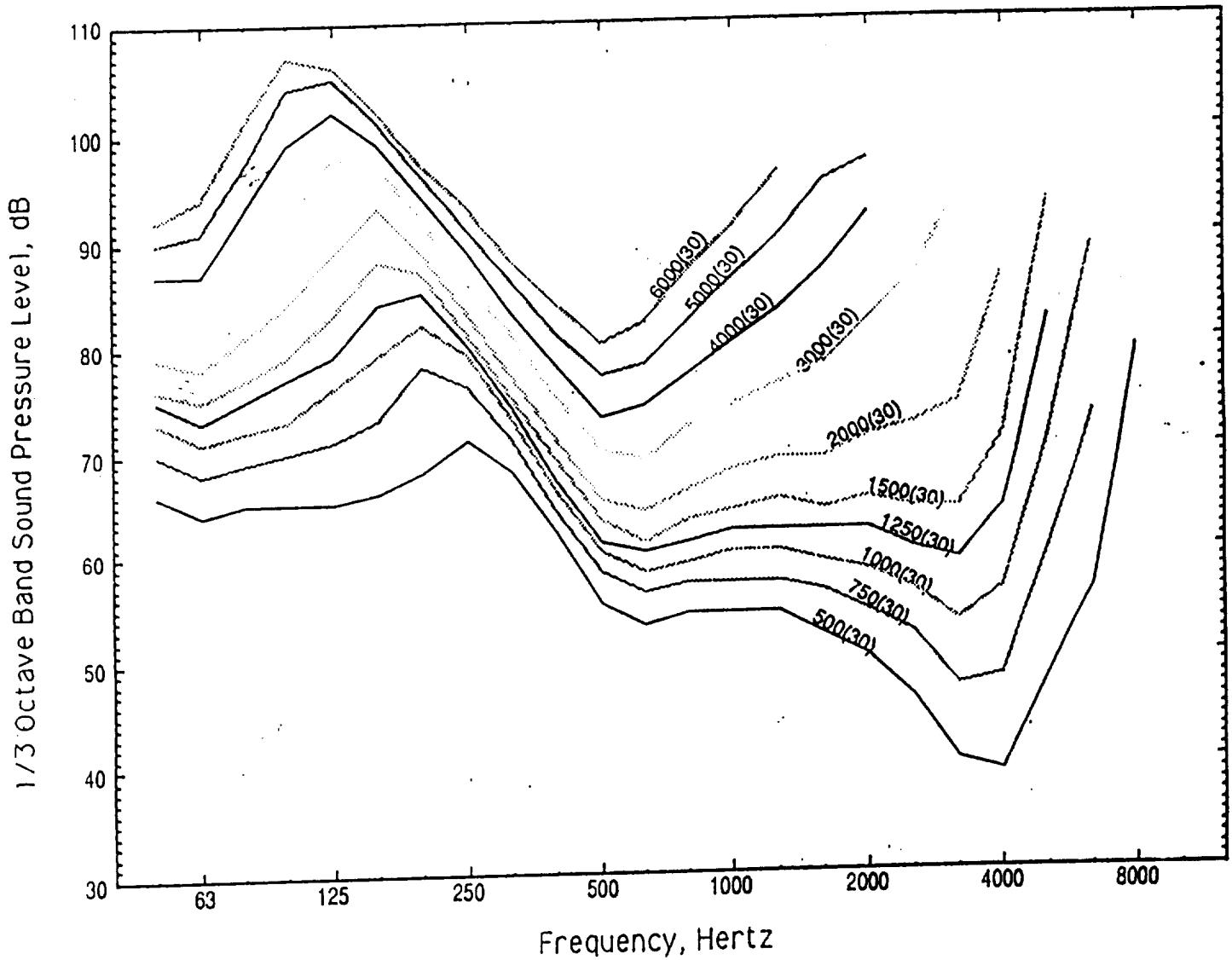

Note: The number in parentheses is the measurement distance in meters

FIGURE 2-3. Level I nondetectability limits for 500 - 6000 meters

MIL-STD-1474D

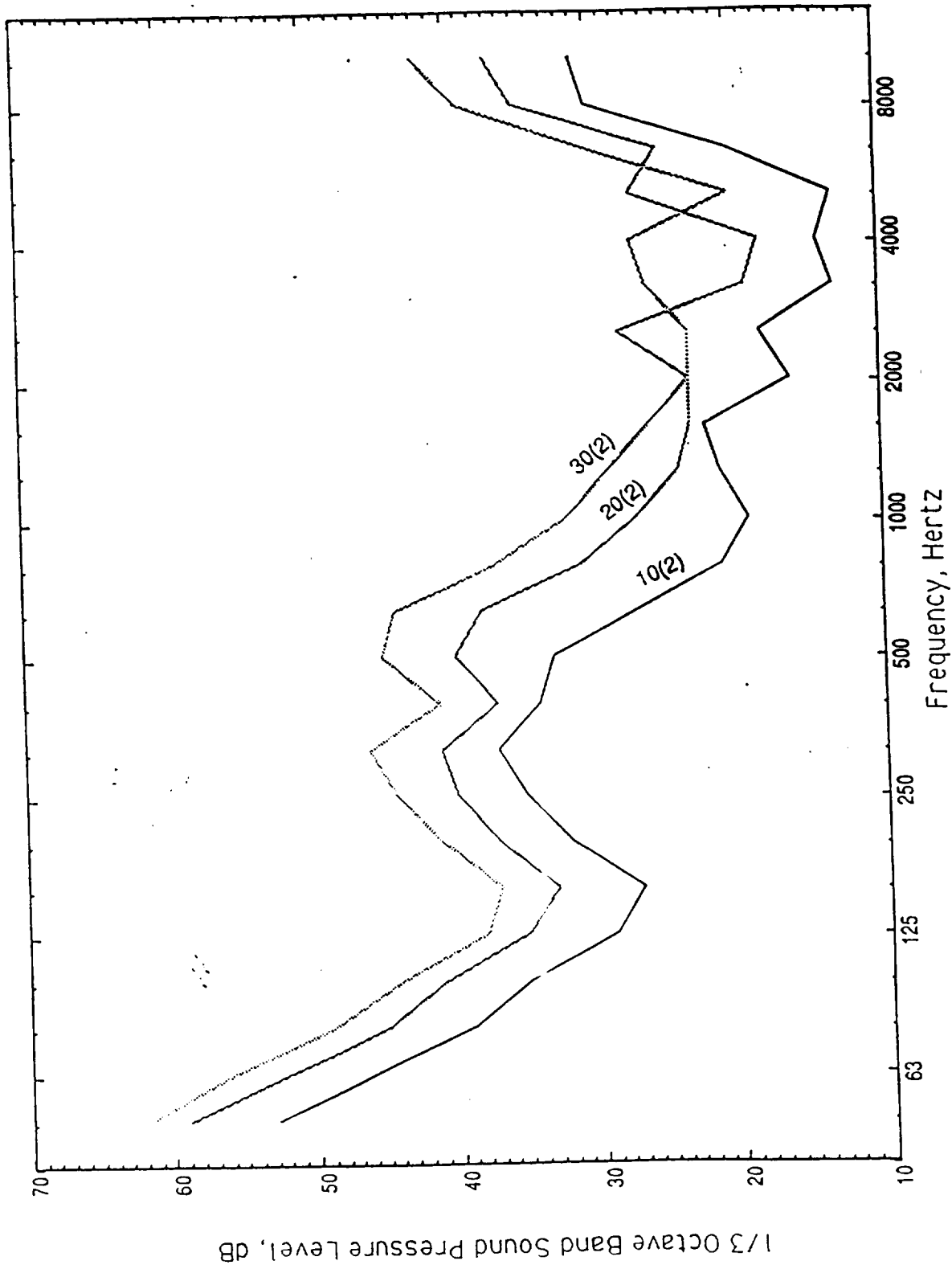

Note: The number in parentheses is the measurement distance in meters

FIGURE 2-4. Level II nondetectability limits for 10 - 30 meters

MIL-STD-1474D

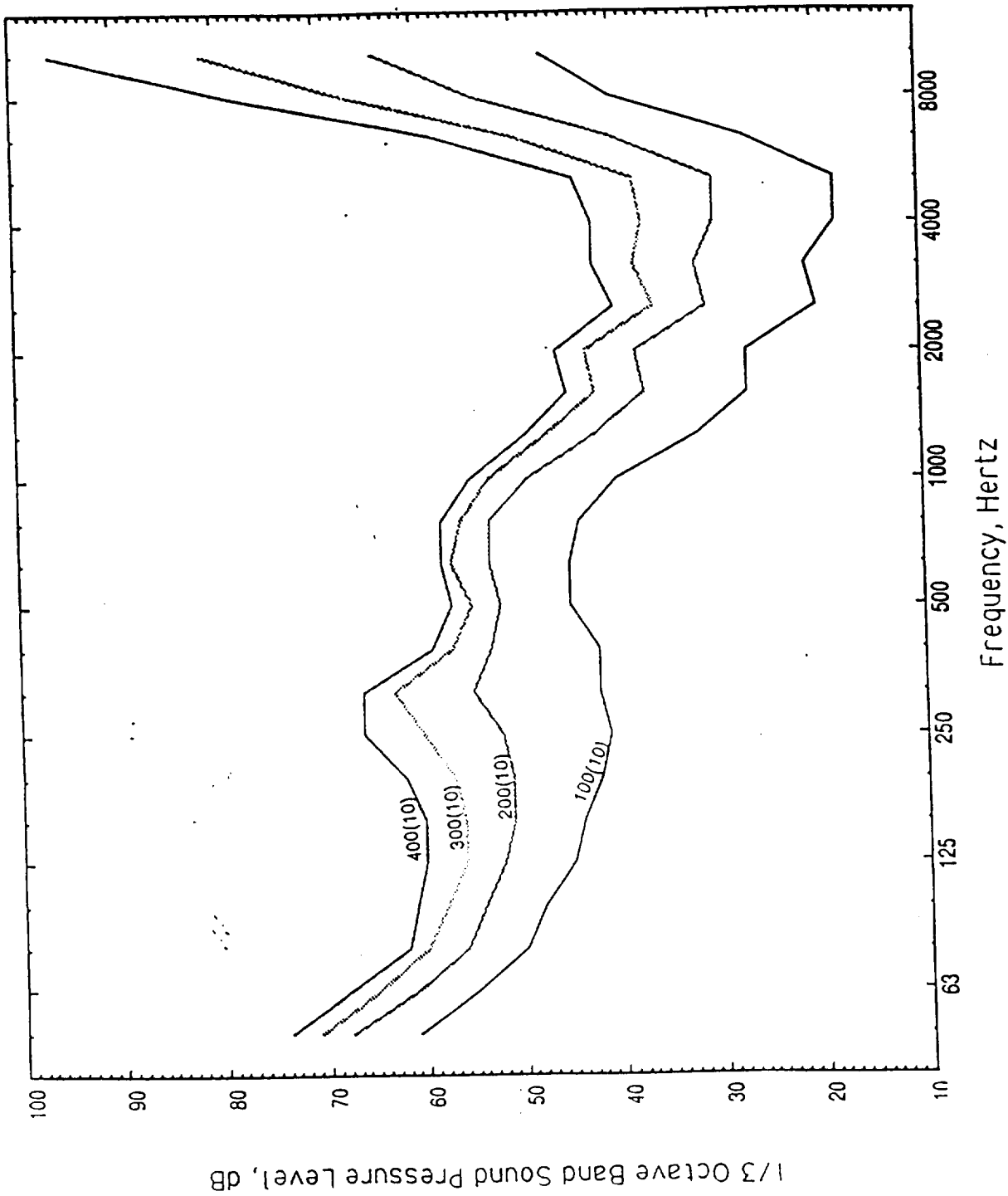

Note: The number in parentheses is the measurement distance in meters

FIGURE 2-5. Level II nondetectability limits for 100 - 400 meters

MIL-STD-1474D

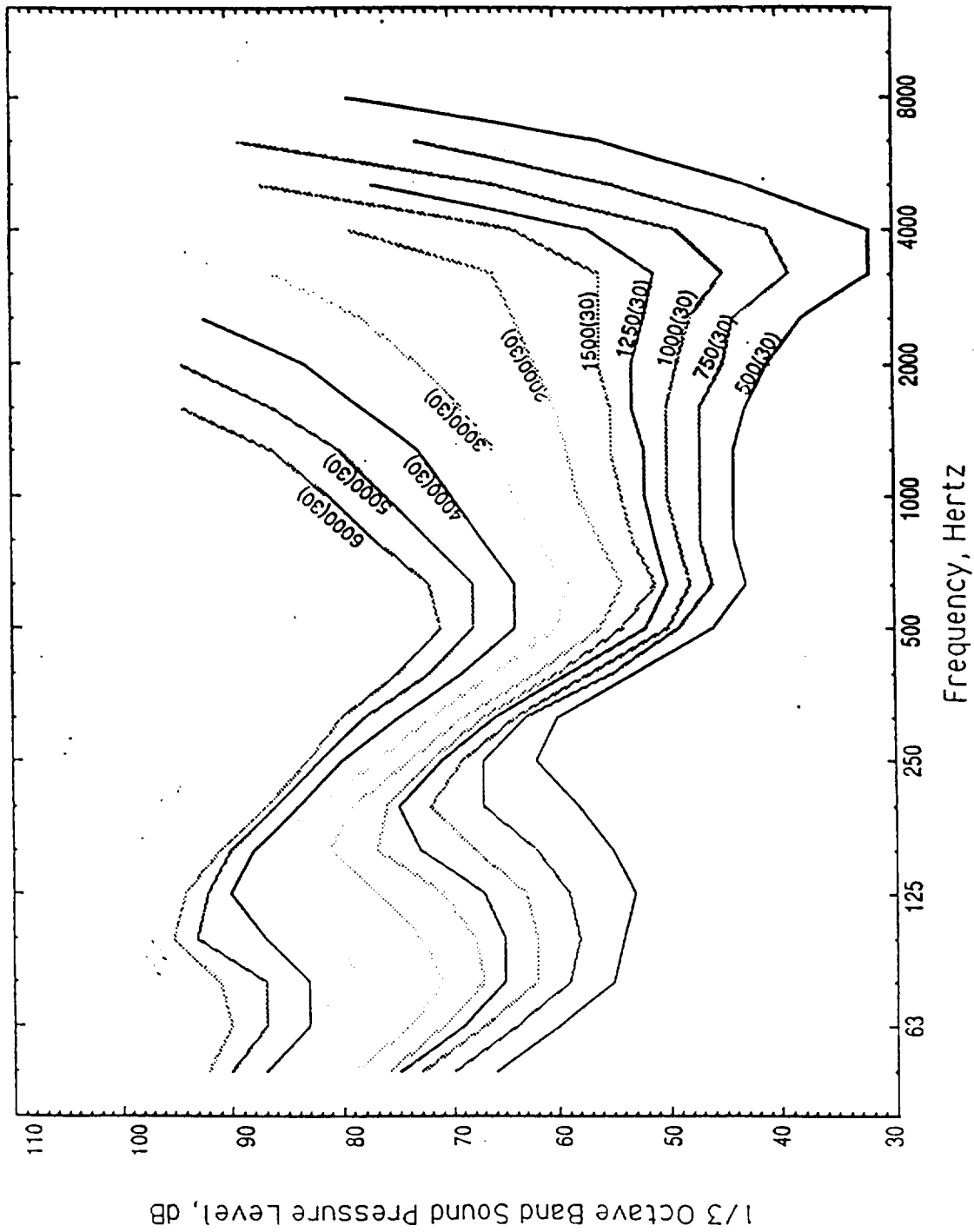

Note: The number in parentheses is the measurement distance in meters

FIGURE 2-6. Level II nondetectability limits for 500 - 6000 meters

MIL-STD-1474D

REQUIREMENT 3

COMMUNITY ANNOYANCE

1. Scope, applicability, and purpose.

1.1 Scope. This Requirement establishes acoustical noise limits and prescribes testing requirements and measurement techniques for determining conformance to community annoyance noise requirements.

1.2 Applicability. This Requirement applies to the acquisition and product improvement of all designed, or purchased (non-developmental items) motor vehicles, construction and materials-handling equipment, mobile generator sets, and portable air compressors for construction equipment. This Requirement does not apply to combat vehicles.

1.3 Purpose. This Requirement provides criteria for designing and selecting materiel having noise levels that do not result in community annoyance.

2. Documents applicable to Requirement 3.

40 CFR 204	Noise Emission Standards for Construction Equipment
MIL-HDBK-1908	Definitions of Human Factors Terms
ANSI S1.1	Acoustical Terminology
SAE J88	Sound Measurement - Earthmoving Machinery - Exterior (DoD adopted)
SAE J366	Exterior Sound Level for Heavy Trucks and Buses (DoD adopted)
SAE J986	Sound Level for Passenger Cars and Light Trucks (DoD adopted)
SAE J1074	Engine Sound Level Measurement Procedure (DoD adopted)

(For applicability and ordering information, see preambles and addresses, respectively, in Section 2 of the basic standard.)

3. Definitions. Terms are defined in accordance with MIL-HDBK-1908. Terms not appearing in MIL-HDBK-1908 are defined in accordance with ANSI S1.1.

4. General Requirements.4.1 Subsystems, sets, groups, and units.

4.1.1 Total system noise. Subsystems, sets, groups, and units including such items as air conditioners, heaters, and auxiliary equipment, shall be selected and integrated in such a manner that noise produced by the entire system does not exceed the requirements of this standard.

4.1.2 Government Furnished Equipment (GFE). The use of GFE shall not eliminate the requirement that the total system conform to this standard.

5. Detailed requirements.5.1 Noise limits.

5.1.1 Criteria. Equipment having a community annoyance noise requirement shall meet the requirements of Table 3-I. (Combat vehicles are exempt.)

5.1.2 Maximum. The sound level limits of Table 3-I shall not be exceeded.

MIL-STD-1474D

5.2 Test requirements. Tests shall be conducted and noise shall be measured in accordance with the appropriate procedures specified in Table 3-I. Portable air compressors for construction equipment shall meet the requirements of 40 CFR 204.

TABLE 3-I. Sound level limits and test procedures for community annoyance

Type of Equipment	Gross Weight (kg)	Distance from Centerline (m)	Sound Level Limit (dBA)	Test Procedure
Motor Vehicles ¹	>4,536	15	80	SAE J366
	<4,536	15	80	SAE J986
Construction and Materials- Handling Equipment ¹		15	88	SAE J88
Mobile Generator Sets		7	70	SAE J1074

¹For equipment wider than 2.75 m, the 15 m distance shall be measured from the side of the vehicle closest to the microphone

6. Notes.

(This section contains information of a general or explanatory nature which may be helpful, but is not mandatory.)

6.1 Intended use. This Requirement is intended for use as a community annoyance (acceleration, drive-by, stationary) design standard for military ground materiel, cited contractually in system specifications, and elsewhere, and for use as a basis for that part of noise testing where design characteristics are assessed for purposes of acceptance. It is not intended for use to express binding requirements in conceptual and other early acquisition phases. The Requirement may be applied to traditional, as well as non-developmental item (NDI) acquisitions.

6.2 Associated Data-Item-Description (DID). This standard is cited in DoD 5010.12L, Acquisition Management Systems and Data Requirements Control List (AMSDL), as the source document for the following DID. When it is necessary to obtain the data, the DID must be listed on the Contract Data Requirements List (DD Form 1423) except where the DoD Federal Acquisition Regulation Supplement exempts the requirement for a DD Form 1423.

<u>DID Number</u>	<u>DID Title</u>
DI-HFAC-80938B	Noise Measurement Report

The above DID was current as of the date of this Requirement. The current issue of the AMSDL must be researched to ensure that only the current and approved DID is cited on the DD Form 1423.

6.3 Information to the development test agency. Developing agencies should make appropriate information available to the development test agency, as required, to ensure that test conditions and evaluation of results are consistent with system requirements, specified hearing protection requirements, if any, and general procuring activity-specified requirements relevant to the provisions of this Requirement.

MIL-STD-1474D

REQUIREMENT 4

IMPULSE NOISE IN PERSONNEL-OCCUPIED AREAS

1. Scope, applicability, and purpose.

1.1 Scope. This Requirement establishes impulse noise limits and prescribes testing requirements and measurement techniques for determining conformance to impulse noise limits.

1.2 Applicability. This Requirement applies to the acquisition and product improvement of all designed, or purchased (non-developmental items) systems, subsystems, equipment, and facilities that emit impulse noise. This standard is intended to address impulse noise levels emitted during the full range of typical operational conditions.

1.3 Purpose. This Requirement provides criteria for designing and selecting materiel having impulse noise levels that minimize noise induced hearing loss.

2. Documents applicable to Requirement 4.

MIL-HDBK-1908	Definitions of Human Factors Terms
ANSI S1.1	Acoustical Terminology
ANSI S1.4	Sound Level Meters, Specification for (DoD adopted)

(For applicability and ordering information, see preambles and addresses, respectively, in Section 2 of the basic standard.)

3. Definitions. Terms are defined in accordance with MIL-HDBK-1908. Terms not appearing in MIL-HDBK-1908 are defined in accordance with ANSI S1.1.

4. General Requirements.

4.1 Subsystems, sets, groups, and units. See 4.1 of the basic standard.

4.2 Posting of noise hazard areas. If impulse noise exceeds 140 dB peak pressure level at personnel-occupied areas (e.g., operator, maintenance, observer, and other control positions), noise hazard signs shall be permanently posted on (or in) the equipment. This provision shall not apply to the exteriors of military combat equipment. Signs should conform to 4.2 of the basic standard.

4.3 Manuals. Where impulse noise exceeds 140 dB peak pressure level at personnel-occupied areas (e.g., operator, maintenance, observer, and other control positions), operation and maintenance manuals (e.g., field and technical manuals) shall contain appropriate discussion of noise hazards. Discussion shall include the requirement for hearing protection, the type of hearing protection recommended, the noise level of the equipment at locations specified in 5.2.1.2 and the distance at which the 140 dB peak pressure level will be met.

4.4 Pulsating equipment. Noise from pulsating equipment (e.g., jack hammers, air tools, impact wrenches) which may be operated for periods of time in excess of one second and where peak level is less than 140 dB, is considered to be steady-state noise.

MIL-STD-1474D

5. Detailed requirements.5.1 Noise limits.

5.1.1 Criteria. Applicable impulse noise limits are identified by the expected number of daily exposures and the type of hearing protection required. Table 4-I identifies the required hearing protection for the respective impulse noise limits and expected number of daily exposures; the corresponding peak levels and B-duration values are shown in Figure 4-1.

5.1.2 Maximum. The initial requirement is that impulse noise shall not exceed the limits specified for limit W in order to meet the hearing conservation criterion for unprotected ears. Limits X, Y, or Z, for which hearing protection is mandatory, shall be selected only if it can be clearly documented that meeting limit W is beyond the state-of-the-art, the cost of reducing the noise level to that specified for limit W is prohibitive, or that system effectiveness will be seriously degraded by reducing the noise level to that specified for limit W. Limits X, Y, or Z shall be selected only with the approval of the procuring activity subject to reduction of the level to the lowest value consistent with the state-of-the-art and the cost and effectiveness factors noted above. Impulse noise levels above limit W (i.e., anything greater than 140 dB) require the use of hearing protectors for any number of exposures per day.

TABLE 4-I. Impulse noise daily exposure limits

Impulse Noise Limit	Maximum Permissible Number (N) of Exposures/Day ¹		
	No Protection	Either Plugs or Muffs	Both Plugs and Muffs
W	-----	Unlimited Exposure	-----
X	0	2000	40000
Y	0	100	2000
Z	0	5	100

¹ A single exposure consists of either (a) a single impulse for non-repetitive systems (systems producing not more than one impulse per second, e.g., rocket launchers fired from the shoulder), or (b) a burst for repetitive systems (systems normally producing more than one impulse per second, e.g., automatic weapons (see 5.4.2.)). The equation for calculating the allowable number of exposures per day is:

$$N_1 = 10^x \text{ where } x = \frac{1}{5} [177 - L + 6.64 \log_{10} \frac{200}{T}],$$

$$N_2 = 20 \times N_1, \text{ and}$$

N_1 = allowable number of impulses/day (single protection)

N_2 = allowable number of impulses/day (double protection)

L = measured peak sound pressure level, in dB

T = measured B-duration in milliseconds

MIL-STD-1474D

5.2 Test requirements.5.2.1 General.

5.2.1.1 Acceptance criteria. To be acceptable for use under the impulse noise limit category selected in 5.1.1, the measured highest peak pressure level and B-duration shall be below the appropriate impulse-noise requirement as shown in Figure 4-1.

5.2.1.2 Measurement location. Measurements shall be made at each operator or crew position and, if required, at a reference location specified in 5.4.5.1. Because reflective surfaces will alter the acoustic exposure, there may be some environments where additional measurements may be appropriate. For example, additional measurements may be made to assess the impulse noise of persons firing weapons from a prone position, a foxhole, a bunker, or an enclosed area. Where the operator or crew station(s) is not clearly defined, the noise measurement position(s) shall be designated by the procuring activity.

5.2.1.3 Replications. For those systems having an existing impulse noise data base from at least 10 events, a minimum of three impulses shall be measured for each condition. Where a limited data base exists for a system or where a system design change may influence the impulse noise, a minimum of five impulses shall be measured for each condition. The peak pressure levels and B-durations from these three or five shots shall be sufficient to define the impulse noise characteristics if the range of peak pressure levels does not exceed 3 dB or 5 dB, whichever applies. If this range is exceeded, additional measurements shall be made until the number of measurements equals or exceeds the range in dB.

5.2.1.4 Recording procedure. The pressure waveform shall be obtained by analog or digital means. It may be displayed directly on a cathode-ray oscilloscope (or equivalent) and photographed, recorded with an FM tape recorder, or stored digitally.

5.2.1.5 Noise contours. Where the impulse noise level exceeds 140 dB, the distances and directions from the noise source at which the noise level is equal to 140 dB shall be determined. In addition, the distances and directions from the source at which the noise level is equal to the specified impulse noise limit category (X, Y, or Z) shall be determined if desired. Where the 140-dB contour is too far from the source to make its direct measurement practical, its location may be extrapolated from measurements made at a distance producing a level not greater than 150 dB and assuming spherical divergence.

5.2.2 Test environment.

5.2.2.1 Reflecting surfaces. Where practical, measurements shall be made with no reflecting surfaces, including personnel, within 10 m of both the test item and the transducers. For weapons that must be supported, a stand shall be used having minimal reflecting or obstructing surfaces. An unimpeded reflecting path from the noise source(s) to the ground and back to the transducers shall be provided.

5.2.2.2 Weather conditions. The effect of weather conditions (e.g., temperature, humidity, and barometric pressure) on the performance of all instruments should be considered. Instrumentation can be affected by low temperatures and caution should be exercised. Measurements should normally be made at wind speeds below 20 km/h. However, this guideline may be eased when measuring high sound pressure levels.

5.2.2.3 Background noise. Background noise, including wind noise, shall be at least 40 dB below the peak pressure level being measured for acceptance (see 5.2.1.1) and at least 20 dB below the peak pressure level for noise contours (see 5.2.1.5).

MIL-STD-1474D

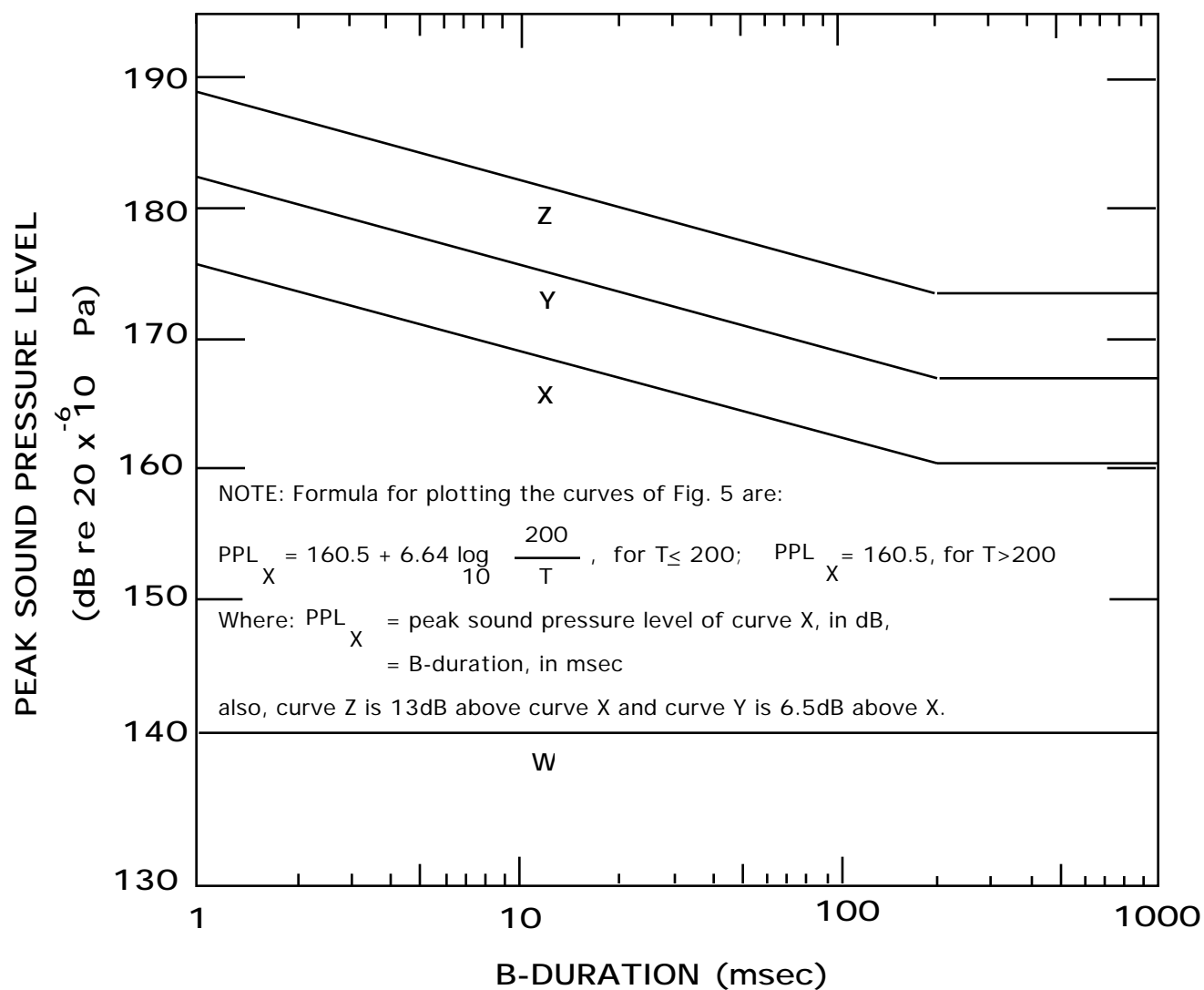

NOTES

1. See Table 4-I to select curve for use.
2. For peak sound pressure levels falling between (but not outside) the labeled curves, the permitted number of exposures per day may be interpolated based on a relationship of 1.5 dB per factor of 2 in the number of rounds.
3. Use of levels in excess of limit W requires hearing protection.

FIGURE 4-1. Peak sound pressure levels and B-duration limits for impulse noise

MIL-STD-1474D

5.3 Instrumentation.5.3.1 Instrument specifications.5.3.1.1 Transducers.

5.3.1.1.1 Undamped resonance. Undamped resonance shall be not less than 100 kHz.

5.3.1.1.2 Time constants. For other than DC response, time constants shall be not less than 200 ms.

5.3.1.1.3 Non-linearity. Non-linearity shall be not greater than 3% of full scale output.

5.3.1.1.4. Sensor surfaces and holders. Diameters of sensor surfaces shall be not more than 6.4 mm. Transducer holders should be small and minimize flow interference over the sensor surface.

5.3.1.1.5 Rise-time. Rise time capability shall be less than 1/20 of the measured A-duration of the impulse and should be not more than 20 microseconds. Cables that cause an increase in measured rise time shall not be used.

5.3.1.1.6 Acceleration sensitivity. Acceleration sensitivity shall be less than 0.014 kPa/g in the axial direction and less than 0.069 kPa/g in the transverse direction.

5.3.1.1.7 Temperature effects.

5.3.1.1.7.1 Selection. Transducers shall be chosen to minimize the effects of temperature under the expected test conditions. Output shall be corrected from temperature versus sensitivity curves for the individual transducer.

5.3.1.1.7.2 Protection. If necessary, transducers should be protected from flash and thermal effects by smoothly covering the sensing surface with a layer of black electrical tape plus a layer of silver tape, or equivalent, which does not modify the sensitivity or frequency response of the transducer.

5.3.1.1.8 Shock, vibration, and ground path isolation. Transducers shall be isolated from any accelerating surfaces to prevent microphonics. Cables should be protected from shock waves by taping them to the stand in a location that minimizes exposure to shock waves. They should be positioned in a direction away from the propagation of the shock wave. All connectors should be isolated from the stand and other grounded objects to prevent multiple ground paths.

5.3.1.1.9 Transducer applications.

a. For measurements above 40 kPa (186 dB), pointed or disc-shaped piezoelectric or piezoresistive probes with good aerodynamic characteristics shall be used.

b. For measurements below 40 kPa (186 dB), piezoelectric or piezoresistive probes having a blunt cylinder shape may be used.

c. For measurements above 7 kPa (171 dB), condenser microphones shall not be used.

5.3.1.2 Recording systems. The complete data acquisition system shall provide a minimum of 35 dB signal-to-noise ratio.

MIL-STD-1474D

5.3.1.2.1 FM recording. The FM tape recorder (if used) shall have a frequency response of DC to 40 kHz or greater, as defined by the Inter Range Instrumentation Group (IRIG) standards. The recorder's reproduce amplifier output filters shall be operated in the linear (optimal transient) phase mode.

5.3.1.2.2 Digital recording. Sampling rate shall be a minimum of 160,000 samples/sec. The analog signal shall be filtered, using a Bessel type, with 40 kHz cutoff frequency. The roll-off rate shall be not less than 36 dB/octave.

5.3.2 Calibration.

5.3.2.1 General. Proper calibration procedures, which include the influence of transducers, cables, amplifiers, recorders, and other instrumentation, shall be accomplished at least daily.

5.3.2.2 Calibration method. Transducers shall be calibrated in a manner consistent with their time constant. Methods may employ sinusoidal pressure generators, pulse calibrators, dead weight calibrators, or shock tubes.

5.3.2.3 Electrical calibration. Electrical calibration of all instrumentation following the transducer is acceptable for field use provided one of the aforementioned calibrations is accomplished on the transducer immediately before and after field use.

5.4 Measurement procedure.

5.4.1 Single-impulse systems. The pressure history of the impulse noise shall be obtained by producing one impulse at a time.

5.4.2 Repetitive systems. The B-duration of a single impulse shall be determined. The number of impulses produced within the first 200 ms shall also be determined. This number of impulses shall be multiplied by the average B-duration of single impulses to determine an effective B-duration. This B-duration shall be used to establish the maximum allowable peak pressure level for the repetitive system.

5.4.3 Multicharge systems. For systems with various charges (e.g., separately loaded artillery ammunition), the charge producing the highest peak pressure level shall be measured in addition to those producing lower levels.

5.4.4 Weapon position. Weapons shall be tested in all positions and in the system locations from which they are normally fired. Standing position for shoulder-fired and hand-held weapons is defined as being mounted with the barrel or tube centerline 1.60 m above and parallel to the ground.

5.4.5 Transducer locations. For shoulder-fired and hand-held weapons, transducers shall be located at the center of each operator or crewmember's probable head location. For other weapons the transducer shall be positioned 1.60 m above the ground surface; for sitting locations it shall be 80 cm above the seat. When the operator must be present, the measurement shall be made 15 cm from the ear closest to the noise source (i.e., muzzle or breech, as the case may be) on a line between the operator's ear and the noise source.

5.4.5.1 Reference transducer.

a. If required, a transducer shall be placed 200 cm to the side of the major noise source of the weapon (e.g., perpendicular to the muzzle for closed breech systems and perpendicular to the rear for rocket launchers), with the weapon and the sensor 160 cm above the ground.

MIL-STD-1474D

b. If required, a reference transducer shall be located on the 135-degree or 225-degree radial (taking the line-of-fire as 0 degrees). For weapons of bore diameter greater than 20 mm, this transducer shall be located at a distance of 50 bore diameters measured from a point directly under the muzzle with a tube (barrel) elevation of 0 degrees at a height of 160 cm. For weapons of smaller bore diameter, the transducer shall be located at the same elevation as the muzzle, at a distance of 100 cm.

5.4.5.2 Equal pressure contours. Equal pressure contours shall be determined from measurements made at positions around the major noise source of the weapon at angular increments not greater than 45 degrees. The muzzle, muzzle extension, or breech, whichever is the major source, shall be at the grid center. The line of fire shall be in the 0-degree direction. The measurement shall be made as close as possible to the distance that produces the peak pressure level being established. If this distance is too great, the pressure may be extrapolated from measurements somewhat nearer to the weapon (in the free field) assuming a spherical divergence decay rate (6 dB per doubling of distance).

5.4.6 Transducer orientation. Blunt cylinder shaped transducers shall be positioned with the sensing surface facing up if possible. Transducers shall be oriented with reference to the noise source so that the plane passing through the sensing surface includes the noise source. This orientation is defined as grazing incidence (90 degrees). If more than one source is present, such as from a rocket launcher, transducers shall be oriented so that the plane passing through the sensing surface includes the centerline of the tube. This technique will tend to minimize the arrival of shock waves at transducer incidence angles between 0 and 90 degrees, which may cause ringing and overshoot.

5.4.6.1 Interior measurements. For interior measurements, such as inside a tank or other reverberant space where the direction of travel of the major shock wave is uncertain (or where major shock waves are expected to arrive from many directions), transducers shall be positioned with the sensing surface facing up, if possible. Transducers shall be oriented at grazing incidence to the center of the major suspected source, e.g., the muzzle or an open hatch.

5.4.7 Ammunition temperature. Where the impulse noise emanates from rapid burning of a propellant, measurements should also be taken with the round at the upper and lower operating temperature conditions specified by the system requirements.

5.4.8 Personnel limits and locations during tests.

5.4.8.1 Operator(s). During testing, the operator and/or crew shall not occupy the location(s) where the noise is being measured unless essential to the operation of the test item.

5.4.8.2 Interior noise measurements. Interior measurements shall be made with the minimum number of people in the area.

5.4.9 Guidelines. The following guidelines should be observed in addition to those specified in the instrument manufacturer's manual.

5.4.9.1 Systems. Care should be taken to maintain proper signal levels, terminating impedances, and cable lengths on multi-instrument measurement systems. (A microphone windscreen may be used provided that its effect is less than 1 dB under zero wind velocity conditions for the noise source being measured.)

MIL-STD-1474D

5.4.10 Data analysis.

5.4.10.1 Filtering. Data shall be analyzed through a low-pass 40 kHz filter of the Bessel type (36 dB/octave roll-off).

5.4.10.2 Weighting networks. If used, weighting networks shall meet the requirements of ANSI S1.4.

5.4.10.3 Analog-to-digital (A-D) converters. A-D converters shall have a 10-bit word size or greater.

5.4.10.4 FM recordings. Analysis of FM tape recordings may be done with appropriate speed-reduction techniques using readout devices having proper frequency response.

5.4.10.5 Standard conditions. Data shall be reported without being scaled to standard conditions. However, temperature and pressure conditions shall be reported so that peak pressure, duration, and impulse data may be scaled to standard conditions, if required (101.325 kPa, 288.16 degrees K), using Sach's scaling laws.

5.4.10.6 Acoustic energy. If the energy per unit area is to be computed, the specific acoustic impedance of air at the above standard conditions is 417 N s/m^3 .

5.5 Data recording. See 5.2 of basic standard.

6. Notes.

6.1 Intended use. This Requirement is intended for use as an impulse noise criteria design standard for military materiel, cited contractually in system specifications, and elsewhere, and for use as a basis for that part of noise testing where design characteristics are assessed for purposes of acceptance. It is not intended for use to express binding requirements in conceptual and other early acquisition phases. The Requirement may be applied to traditional, as well as non-developmental item (NDI) acquisitions.

6.2 Associated Data-Item-Description (DID). This standard is cited in DoD 5010.12L, Acquisition Management Systems and Data Requirements Control List (AMSDL), as the source document for the following DID. When it is necessary to obtain the data the applicable DID must be listed on the Contract Data Requirements List (DD Form 1423) except where the DoD Federal Acquisition Regulation Supplement exempts the requirement for a DD Form 1423.

<u>DID Number</u>	<u>DID Title</u>
DI-HFAC-80938B	Noise Measurement Report

The above DID was current as of the date of this Requirement. The current issue of the AMSDL must be researched to ensure that only the current and approved DID is cited on the DD Form 1423.

6.3 Details specified by the procuring activity. Applicable details, such as the following, should be specified by the procuring activity in the request for proposal (RFP) and in appropriate follow-up requirements documentation.

6.3.1 Hearing protection. When it is known that certain types of hearing protection will interfere with the use of helmets or other equipment.

MIL-STD-1474D

6.3.2 Measurement locations when not clearly defined. (See 5.2.1.2.)

6.4 Information to the development test agency. Developing agencies should make appropriate information available to the development test agency, as required, to ensure that test conditions, impulse noise limit selection, and evaluation of results are consistent with system requirements, specified hearing protection requirements, if any, and general procuring activity-specified requirements relevant to the provisions of this Requirement.

6.5 Determination of B-duration. To establish the B-duration of an impulse noise it is necessary to find the primary portion of the event plus the presence of significant subsequent fluctuations.

6.5.1 Primary portion. The primary portion of an impulse noise is determined as follows:

Let L^+ be the line 20 dB below the positive peak overpressure and parallel to the baseline (see Note).

Let L^- be the reflection of L^+ through the baseline.

Let T_1 be defined by $T_1 = N \times (A - \text{duration})$,

where N is an integer given the initial value of 5, and T_1 can be no greater than 30 ms.

Let T be the time from the first rise above ambient exceeding the line L^+ , to the point P at the start of the first subsequent interval of duration greater than or equal to T_1 during which the overpressure lies entirely between L^+ and L^- .

If the point P is within time T_1 of the first rise, decrease N by 1 and reapply the criterion. T is defined by the largest N found such that $T > T_1$. ($N=1$ always works, but this may not be the largest such N .)

NOTE: The baseline is defined by taking 5% of the difference between the positive and negative peak pressure levels. Working back in time from the peak pressure level, average the level over 5 ms intervals until all deviations about the average do not exceed the 5% difference. This average is then used as an estimate of the baseline. The baseline is then used along with the peak pressure level to calculate L^+ and L^- . An acceptable baseline is one in which the 5 ms interval precedes the first excursion exceeding L^+ or L^- by no more than 2 ms.

Now let $R = .3 \times (T)$. If $R \leq T_1$, T is the duration of the primary portion. If $R > T_1$, find the point Q at the start of the first interval past P of duration R during which the overpressure lies entirely between L^+ and L^- . The primary portion is then from the start of the interval T to the point Q .

6.5.2 Secondary fluctuations. Significant subsequent fluctuations are defined as pressure excursions exceeding L^+ or L^- whose total (summed) duration is greater than 10% of the primary portion of the impulse noise.

6.5.3 B-duration examples and algorithm. Figures 4-2, 4-3, 4-4 and 4-5 provide sample determinations of B-duration. Figure 4-6 is a flow diagram for finding B-duration.

MIL-STD-1474D

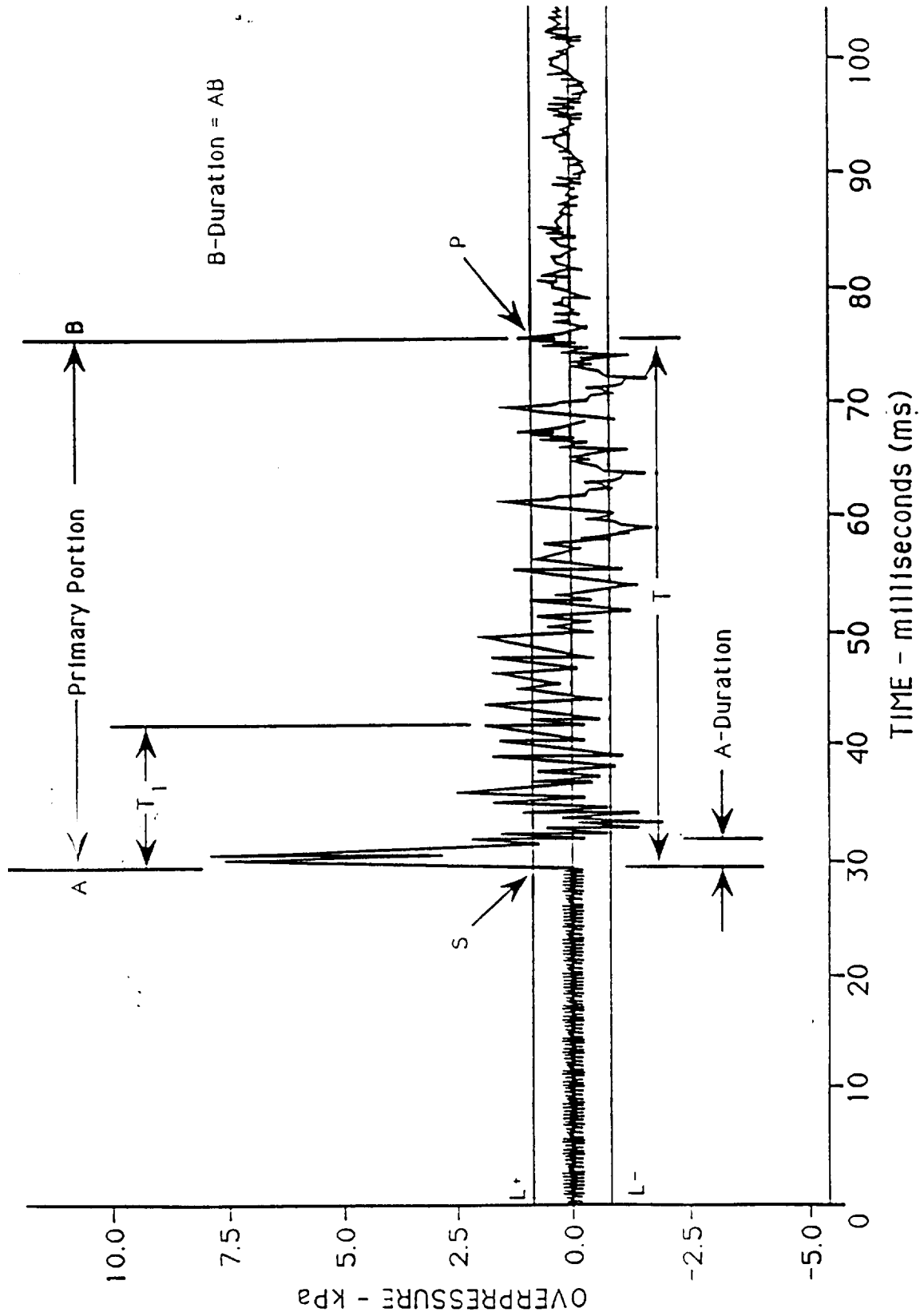

FIGURE 4-2. Sample determination of B-duration

MIL-STD-1474D

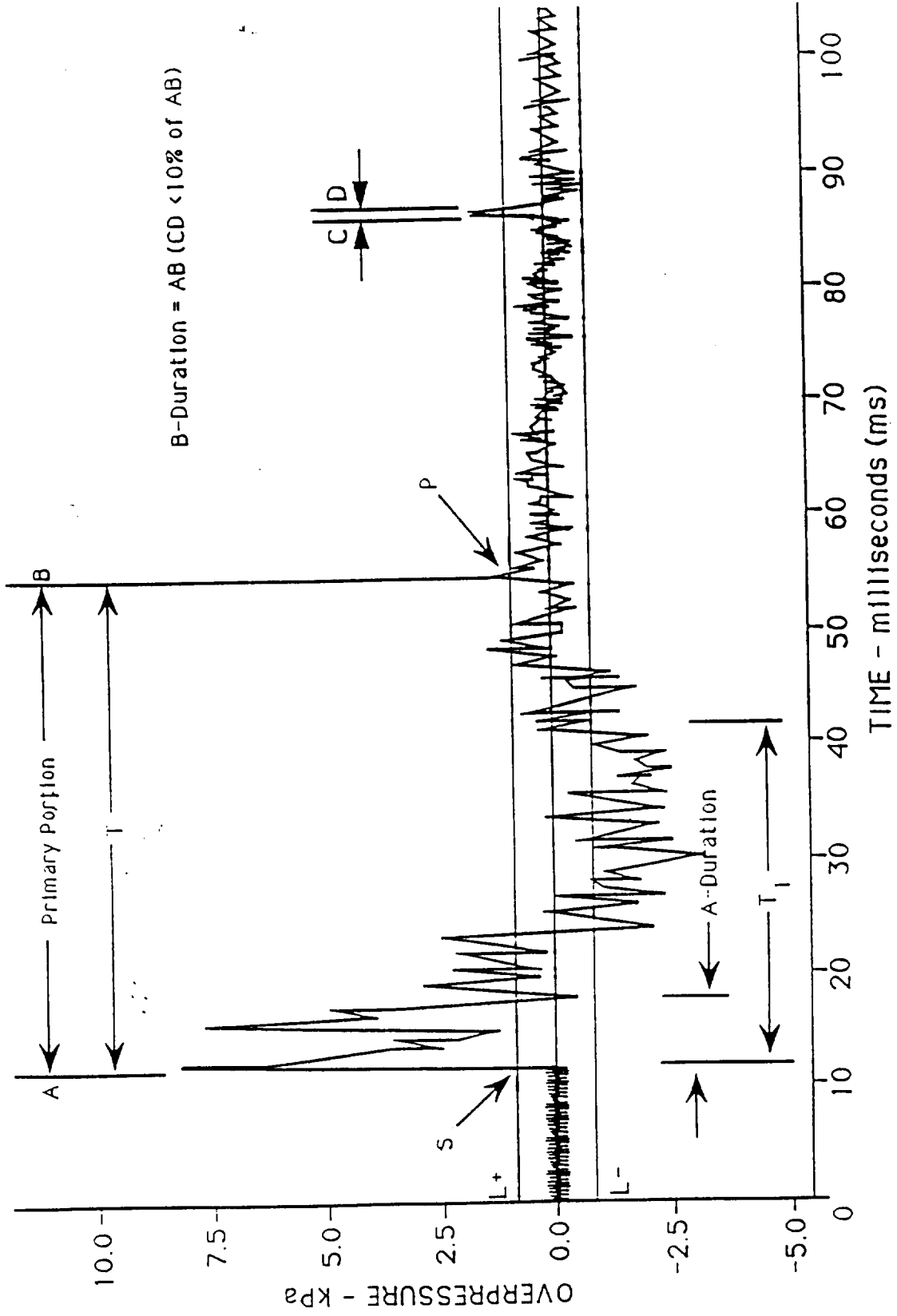

FIGURE 4-3. Sample determination of B-duration

MIL-STD-1474D

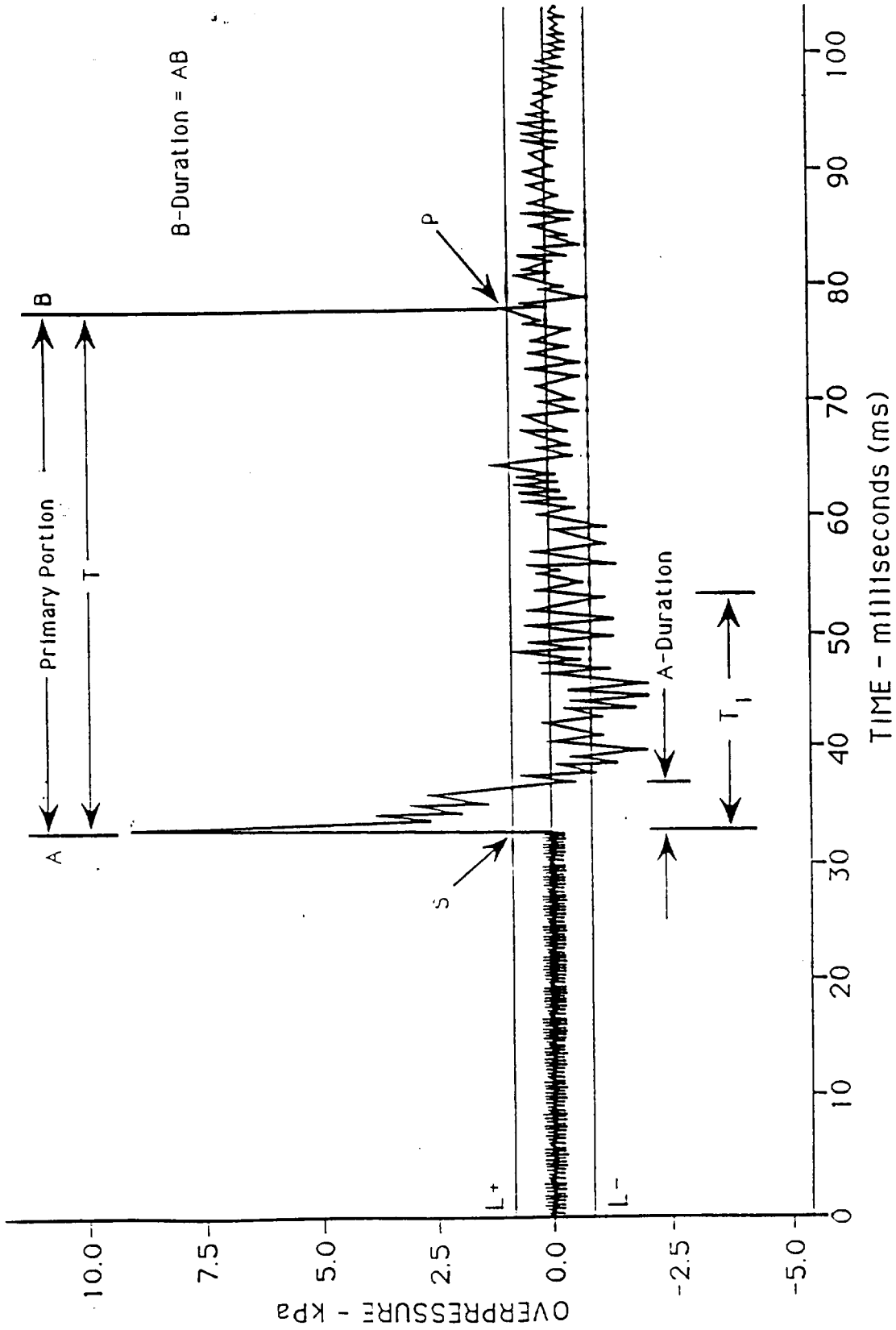

FIGURE 4-4. Sample determination of B-duration

MIL-STD-1474D

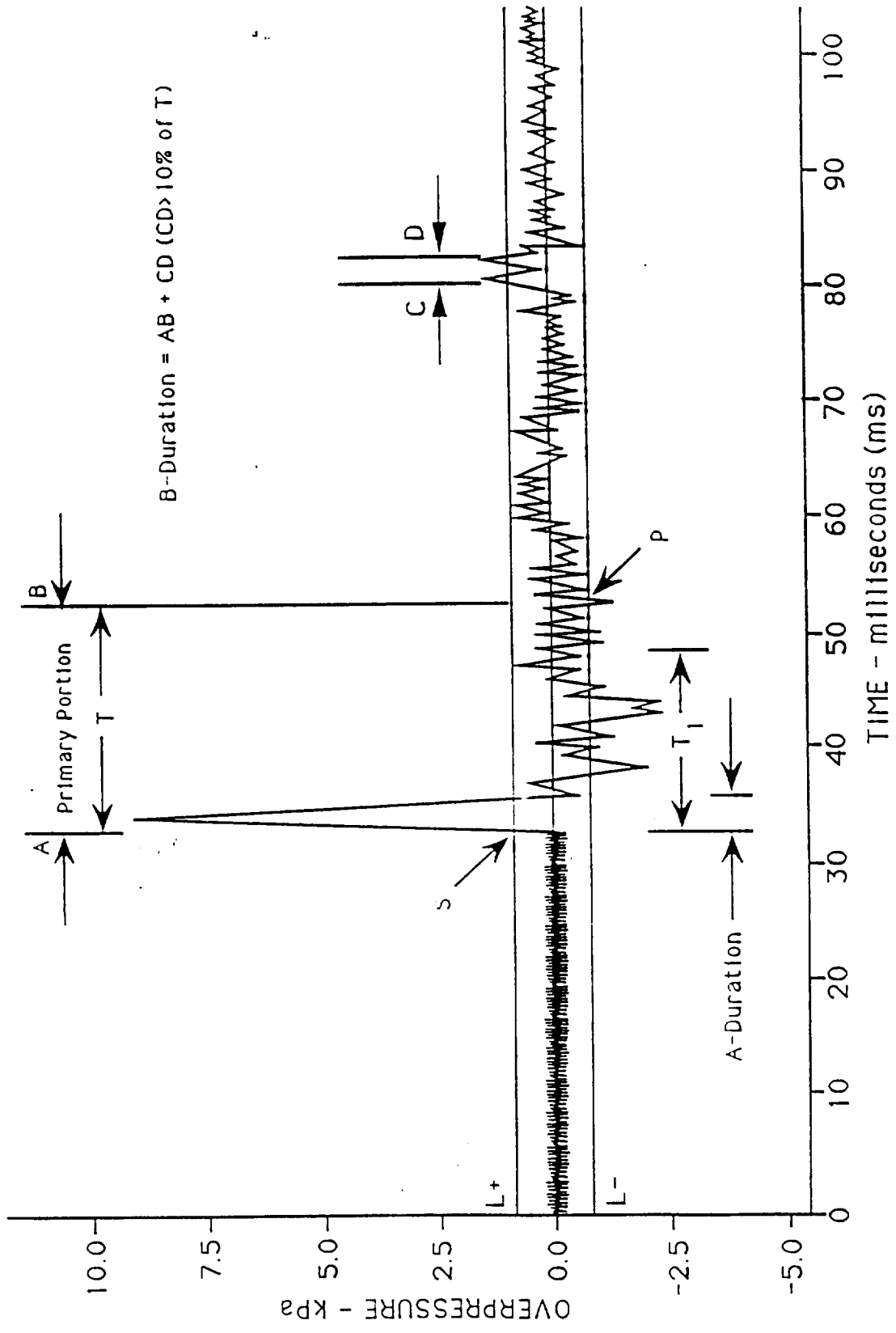
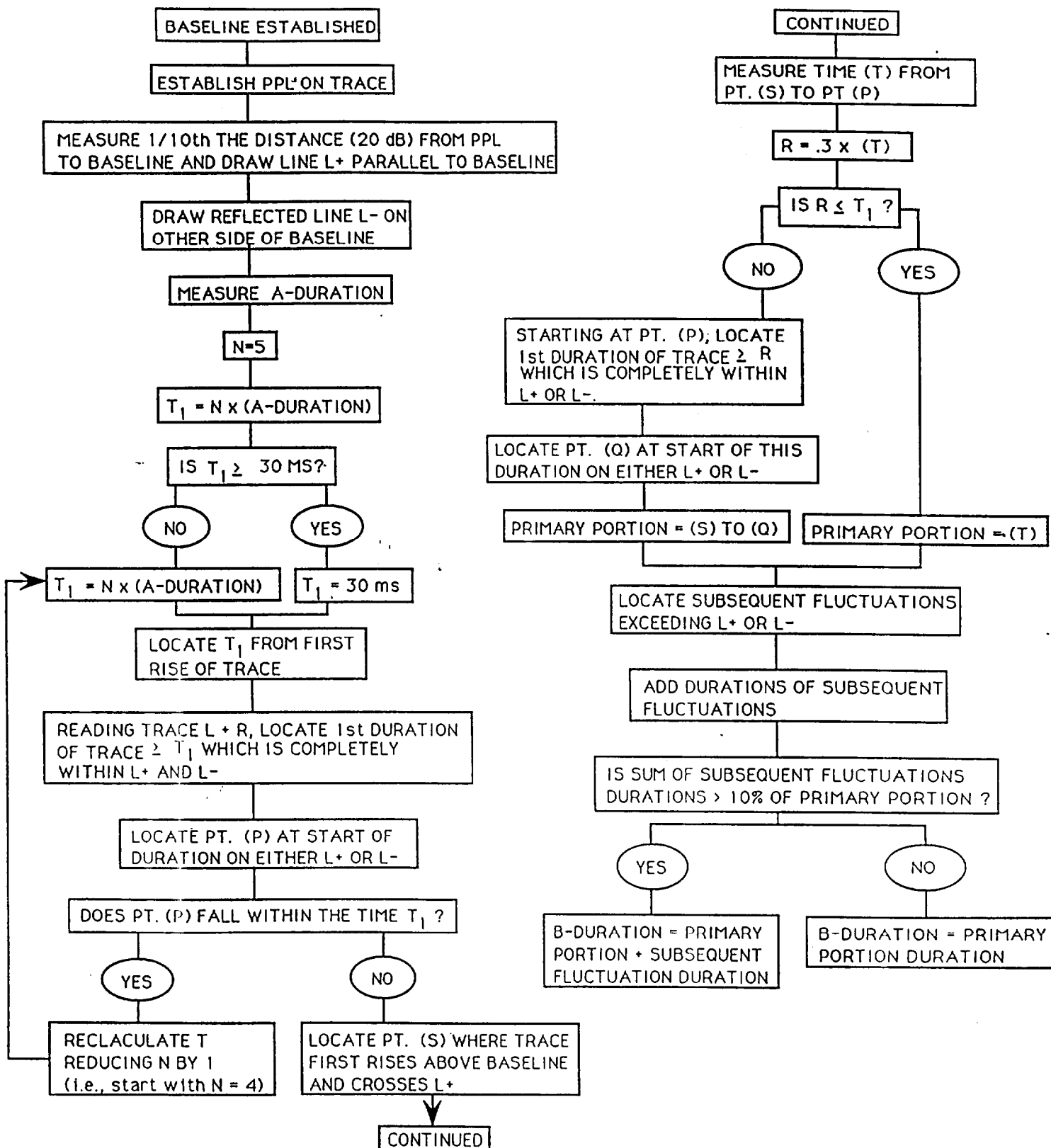

FIGURE 4-5. Sample determination of B-duration

MIL-STD-1474D

FIGURE 4-6 Determination of B-Duration

MIL-STD-1474D

REQUIREMENT 5

SHIPBOARD EQUIPMENT NOISE

1. Scope, applicability, purpose, and approach.

1.1 Scope. This Requirement prescribes instrumentation and procedures required for the measurement and analysis of, and maximum acceptable sound level criteria for, airborne sound generated by shipboard equipment.

1.2 Applicability. This Requirement supplements specifications and similar documents applicable to all shipboard equipment.

1.3 Purpose. Airborne sound measurements are conducted to demonstrate that equipment levels are within the limits specified herein.

1.4. Approach.

1.4.1 Measurement. Two basic types of measurement are required by this Requirement: weighted sound pressure (average for all measurements and peak for selected measurement) levels; and octave band sound pressure levels.

1.4.2 Acceptance criteria. Airborne sound acceptance criteria are specified in 5.1.

1.4.3 Acceptability of equipment. Equipment is acceptable when none of the airborne levels measured at the designated locations exceed the applicable acceptance criteria.

2. Documents applicable to Requirement 5.

MIL-P-15024	Plates, Tags, and Bands for Identification of Equipment
MIL-M-17185	Mounts, Resilient; General Specifications and Tests for (Shipboard Application)
MIL-M17508	Mounts, Resilient: Types 6E100, 6E150, 7E450, 6E900, 6E2000, 5E3500, 6E100BB, 6E150BB, 7E450BB, and 6E900BB
MIL-M-19379	Mounts, Resilient, Mare Island Types 11M15, 11M25, and 10M50
MIL-M-19863	Mounts, Resilient: Type 5B5,000H
MIL-M-21649	Mounts, Resilient, Type 5M10,000H
MIL-HDBK-1908	Definitions of Human Factors Terms
ANSI S1.1	Acoustical Terminology
ANSI S1.4	Sound Level Meters, Specification for (DoD adopted)
ANSI S1.6	Preferred Frequencies and Band Numbers for Acoustical Measurements (DoD adopted)
ANSI S1.10	Calibration of Microphones, Method for the (DoD adopted)
ANSI S1.11	Octave-Band and Fractional-Octave-Band Analog and Digital Filters, Specification for (DoD adopted)

(The above documents are cited either in this Requirement or in Sections 3, 4, or 5 of the basic standard. For applicability and ordering information, see preambles and addresses, respectively, in Section 2 of the basic standard.)

MIL-STD-1474D

3. Definitions.

3.1 Terms. Except for the following, terms are defined in accordance with MIL-HDBK-1908. Terms not appearing below or in MIL-HDBK-1908 are defined in accordance with ANSI S1.1.

3.1.1 Mounting.

3.1.1.1 Resiliently mounted equipment. Equipment that is isolated from a support structure by Navy approved resilient mounts. Navy approved resilient mounts are mounts conforming to MIL-M-17185, MIL-M-17508, MIL-M-19379, MIL-M-19863, or MIL-M-21649. For the purposes of this Requirement, DIM mounted equipment is considered to be solidly mounted equipment.

3.1.1.2 Solidly mounted equipment. Equipment that is attached directly to the supporting structure. For the purposes of this Requirement, DIM mounted equipment is considered to be solidly mounted equipment.

3.2 Symbols. Symbols used herein are as follows:

f_c	=	Band-center frequency (geometric)
f_1	=	Lower band-edge frequency
f_2	=	Upper band-edge frequency
L_A	=	A-weighted sound (pressure)
L_C	=	C-weighted sound (pressure)
L_p	=	Sound pressure level
DIM	=	Distributed isolation material (see 3.1.1)

4. General Requirements.

4.1 Equipment sampling. If sampling is called for by the acquisition specifications or the contract or order (see 6.3), selection of equipment for test shall be on the basis of conformance to the drawing requirements for that equipment, and shall not consider advance measurements, observations, or opinions about the acoustical performance of the particular equipment sample.

4.2 Test records.

4.2.1 Reference quantity identification. The applicable reference quantity shall be indicated on every table, figure, and graph, and at least once in the text. The reference quantity may be introduced by "re" which indicates that the level is "with reference to". For example, the 125 Hz octave band level re 20 μ Pa is 85 dB.

4.2.2 Measurement bands. The bandwidths of the measurement basis shall be identified together with the measured levels. Normal procedure for identifying measured levels shall include the bandwidth and the band center frequency with the level. For example: the one-third octave 100 Hz band level was 85 dB re 20 μ Pa, the 10 Hz band level was 85 dB re 20 μ Pa.

4.2.3 Plotting format. All plots of data in which a level in dB on a linear scale is plotted against frequency on a logarithmic scale shall be made on graphs in which a factor of ten in frequency is equal in length to 25 dB (preferred) or 50 dB. Where the bandwidth of analysis is one-third octave or larger, one factor of ten in frequency shall be 50 mm (preferred) or 2 inches in length. The ordinate and abscissa of all graphs shall be labeled so that levels and frequencies can be readily understood without need to refer elsewhere.

MIL-STD-1474D

5. Detailed requirements.

5.1 Airborne sound acceptance criteria. The octave band sound pressure levels of the equipment, measured at the locations of 5.3 shall not exceed the limits given in table 5-I for the specified equipment grade (see MIL-HDBK-1908). Where no equipment grade has been specified, grade A12 requirements shall apply. No equipment shall have a peak A-weighted sound pressure level in excess of 140 dB. Equipment which fails to meet the acceptance criteria shall not be installed in the ship until the following have been accomplished:

- a. When specified in the contract or order, a sound test failure notification and recommendations report has been prepared for each deficient equipment item measured.
- b. The procuring activity has accepted the deficient equipment or directed the specific course of action.

The final decision, with respect to acceptance, will be made by the Government.

TABLE 5-I. Acceptable octave band sound pressure levels in dB re 20 μ Pa.

Equipment grade	Octave Band Frequency in Hz								
	31.5	63	125	250	500	1000	2000	4000	8000
A3	75	72	69	66	63	60	57	54	51
A12	66	63	60	57	54	51	48	45	42
B	75	72	69	66	63	60	57	54	51
C	72	69	66	63	60	57	54	51	48
D	91	88	85	82	79	76	73	70	67
E	82	79	76	73	70	67	64	61	58

5.2 Instrumentation and obstructions. Measurements shall be made using a microphone connected to a sound level meter. No obstruction, including the instrument operator, shall be between the equipment being measured and the microphone.

5.2.1 Microphone mounting and orientation. The microphone should be mounted on a rigid frame or stand and connected to the sound level meter by a cable at least 2 m long. If the microphone has the random incidence calibration specified in ANSI S1.4, the microphone shall be clamped so that the principal sound arrives at the diaphragm at near grazing incidence. The instructions for the sound level meter being used shall be reviewed to assure that the microphone is properly oriented if other than random incidence calibration has been performed. If the microphone must be attached directly to a hand-held sound level meter, the microphone orientation shall still be the same as that appropriate to the microphone on a cable.

5.2.2 Measurements. Unless otherwise specified (see 6.3), the following measurements shall be made:

MIL-STD-1474D

5.2.2.1 A-weighted sound pressure level measurements. A-weighted sound pressure level (L_A) measurements shall be obtained for all equipment in accordance with 5.2.3.1 and shall be made at the locations specified in 5.3. These measurements shall be used to determine the locations at which the octave band and peak A-weighted sound pressure measurements will be made.

5.2.2.2 C-weighted sound pressure level measurements. C-weighted sound pressure level (L_C) measurements shall be obtained for all equipment in accordance with 5.2.3.1 and shall be made at the locations specified in 5.3. These measurements shall be used to determine the location at which the octave band sound pressure measurements will be made.

5.2.2.3 Octave band sound pressure level measurements. Octave band sound pressure level measurements shall be made for all equipment in accordance with 5.2.3.2 at the location of the highest L_A level and the location of the highest L_C level as measured for 5.2.2.1 and 5.2.2.2. Octave band measurements shall also be made, where applicable, at the location of the operator's head. In addition, octave band measurements shall be made at all other locations where the level exceeds the equivalent A-weighted level of Table 5-II. Equivalent A-weighted sound level is not a criterion but rather a screening tool used to identify where additional octave band sound pressure level measurements must be taken.

TABLE 5-II. Equivalent A-weighted sound levels

Grade	Sound Level (dB)
A3	63
A12	54
B	63
C	60
D	79
E	70

5.2.2.4 Peak A-weighted sound pressure levels. Peak A-weighted sound pressure levels shall be monitored for equipment generating transient sounds using the procedure specified in 5.2.3.3 at the location selected from 5.2.2.1 and, where applicable, at the location of the operator's head.

5.2.2.5 Windscreen performance. When a windscreen is used in accordance with 5.3, and when specified in the contract or order, data shall be prepared (see 6.4) which demonstrates that the windscreen does not change the frequency response characteristics of the microphone by more than 1 dB in any octave bands specified for measurement (see 5.2.3.2). A correction factor which accounts for the change in frequency response may be applied to the measured levels.

5.2.3 Measurement procedures. Unless otherwise specified (see 6.3), measurement procedures shall be as specified herein.

5.2.3.1 A- and C-weighted sound pressure level measurements. A sound level meter, meeting the requirements of ANSI S1.4, type 2 instrument, shall be set on either A-weighting or

MIL-STD-1474D

C-weighting as appropriate and slow meter response, and then used to record the maximum of the meter indication at each location as L_A and L_C .

5.2.3.2 Octave band sound pressure level measurements. Unless otherwise specified (see 6.3), unweighted octave band sound pressure level measurements shall be made for at least the bands with band-centers from 31.5 to 8000 Hz, using an instrument set for slow meter response and with filters at least as good as those specified in ANSI S1.11 for Order 3, Type 3-D, Extended Range filters. The input to the octave band instrument will normally be the output of the sound level meter which was used for the L_A and L_C measurements. If any other input is used, the quality and frequency range of the microphone and associated circuitry shall be that required for a type 2 sound level meter in ANSI S1.4. These measurements shall be compared to the acceptance criteria.

5.2.3.3 Peak A-weighted sound pressure level measurements. The peak A-weighted sound pressure level measurements shall be made using either a peak reading sound level meter or a combination of instruments with equivalent characteristics, such as a sound level meter and an impact meter, or a sound level meter and a calibrated oscilloscope. The measurements shall be made with a sound level meter, or equivalent, meeting the requirements of ANSI S1.4 for a type 2 meter with addition of a measuring circuit that will make a peak sound pressure level measurement where the total rise time of the instrumentation does not exceed 200 μ s. The rise time of the peak detector shall be such that a single pulse of 200 microseconds duration produces a meter indication within a 2 dB of the indication produced by a pulse having a duration of 10 μ s and equal peak amplitude. The amplitude of the 10 microsecond reference pulse shall be such as to produce a meter deflection 1 dB below full scale.

5.3 Measurement locations. Unless otherwise specified (see 6.3), both A-weighted sound pressure level and C-weighted sound pressure level shall be measured at each of the locations described herein. The number of locations depends upon the size and type of the equipment, as indicated on figures 5-1 through 5-4. These figures depict typical equipment configurations; the configuration details are provided for visual reference only. Sound levels shall also be measured at the typical position of an operator's head if the equipment has an operator position associated with it. Microphones shall be placed at locations approximately 1 m from the rectangular envelope which just encloses the equipment, except for the typical position of the operator's head (see 6.3). Also, if the equipment has air openings at any of the designated locations, the microphones may be relocated from the designated location to minimize air flow over the microphone. For such cases, the separation between the measurement location and the designated location shall be minimized and shall be not greater than 30 cm. In addition, a windscreen shall be used on the affected microphone (see 5.2.2.5) to further minimize airflow effects. All distance measurements shall be within plus or minus 10 percent.

5.3.1 Small equipment. For equipment whose maximum dimension is less than 2 m, sound levels (L_A and L_C) shall be measured at a minimum of 5 locations as shown on Figure 5-1; however, valves require measurements at only three locations: two at opposite sides and one at the valve operating mechanism (see figure 5-4). Where measurement at five locations are required, the microphone shall be placed 1 m from the rectangular envelope of the equipment:

- a. on each of the four sides on the vertical centerlines at a distance 1 m above the base of the mounted equipment, or if the 1 m location is above the top of the equipment, at the height of the horizontal centerline of the equipment, and
- b. above the equipment, over the center of the horizontal plane of the envelope.

MIL-STD-1474D

5.3.2 Medium size equipment. For equipment whose maximum dimensions are between 2 and 4 m, the sound levels (L_A and L_C) shall be measured at locations shown on Figure 5-2. The microphone shall be placed 1 m from the equipment envelope:

- a. on each of the four sides on the vertical centerlines at a distance 1 m above the base of the mounted equipment, and at successive intervals of not more than 1 m each along each side of the equipment envelope, and
- b. above the equipment, over the center of the horizontal plane of the envelope and at successive intervals not greater than 1 m apart in the horizontal plane.

For equipment comprised of any sides whose dimension is less than 2 m, the measurement positions shall be in accordance with 5.3.1.

5.3.3 Large equipment. For equipment whose maximum dimensions are greater than 4 m, sound levels (L_A and L_C) shall be measured at locations shown on Figure 5-3. The microphone shall be placed 1 m from the equipment envelope

- a. on each of the four sides on the vertical centerlines at a distance 1 m above the base of the mounted equipment, and at successive intervals of not more than 2 m each along each side of the equipment envelope, and
- b. above the equipment, over the center of the horizontal plane of the envelope and at successive intervals of not more than 2 m in the horizontal plane. For any side whose dimension is less than 4 m, the measurement position shall be in accordance with 5.3.1 or 5.3.2.

5.4 External influences. Measured levels of equipment sound shall not be adjusted to compensate for the effects of ambient magnetic, electrical, and acoustical fields. Ambient effects shall be at least 10 dB below the levels specified for the equipment. No reflecting surface shall be nearer than 1 m to the microphone for any measurement, except measurements where the operator's normal head position is closer than 1 m to the equipment. Corrective measures shall be taken to reduce the effects of external sources on the equipment's measured sound level. Where pipes are connected to the equipment within 1 m of the equipment, a flexible connection shall be inserted in each pipe run between the equipment and any external piping. Acoustical filters, damped piping, or similar devices shall be employed to reduce fluidborne pressure pulsation effects from external sources. The equipment shall be located away from other machinery items. If this is not possible, machinery which is not necessary for the test shall be shut down.

5.5 Mounting of equipment. Unless otherwise specified (see 6.3), mounting methods shall be as specified herein.

5.5.1 Methods. Equipment shall be oriented in its normal shipboard installation position. Equipment shall be resiliently mounted as described below regardless of how the equipment is to be mounted in service. Resilient mounts and subbases or bedplates shall normally be the same ones used for shipboard installation. The subbase used for the equipment evaluation shall not exceed the weight of the shipboard subbase (see 6.3). For the purposes of this Requirement, the terms *subbase* and *bedplate* refer to the support structure required for shipboard installations and necessary for purposes such as to hold one or more components within alignment or to provide a means for attachment to the ship. Resilient mounts used in such a case shall be loaded in accordance with the load range specified in the mount specification. The frequencies of the natural modes of vibration of the mounted equipment in the vertical direction shall not exceed 11 Hz or one-fourth of the lowest forcing frequency, whichever is lower. Resilient mounts conforming to MIL-M-17508, MIL-M-19379, MIL-M-19863, or MIL-M-21649 shall be used where possible. If these mounts cannot be used, commercial mounts that meet the frequency requirements and which

MIL-STD-1474D

are otherwise suitable are acceptable if approved by the contracting activity. When the above mounting methods cannot be met, equipment mounting shall be as approved by the procuring activity. When used in Navy shipboard application, resilient mounts shall be in accordance with MIL-M-17185. The complete assembly shall be supported on a rigid and massive floor, preferably of reinforced concrete or case metal to prevent interaction between the equipment and floor.

5.5.1.1 Foundations. Any foundation pedestals, cradles, or other foundations, required to accommodate resilient mounts, shall assure that the installed mounts provide the vibration isolation of the assembly from the foundation for which the resilient mount is designed. Foundations shall have a natural frequency of not less than 25 Hz and shall not have fixed base natural frequencies within ± 0.4 (square root of 2, minus 1) times the fundamental rotational or other primary forcing frequency of the machinery or equipment. In addition, they shall not have natural frequencies within 0.4 times other machinery or equipment exciting frequencies between 0 and 500 Hz. Exciting frequencies shall include but not be limited to rotational, two times rotational, electrical frequencies and harmonics thereof, pump vane frequencies, pressure pulsations, and ball bearing frequencies. For the purposes of this Requirement, *foundation* refers to support structure which is used below the resilient mounts and which may or may not resemble the shipboard structure.

5.5.2 Mounting fixture. Some equipment may be measured while solidly mounted on a resiliently mounted test fixture. This equipment normally consists of units which have a relatively light framework or structure (e.g., controllers, control cubicles, nonrotating or nonreciprocating equipment) and which is to be solidly mounted on shipboard. For the purposes of this Requirement, *mounting fixture* refers to a structure used solely to resiliently mount equipment for noise testing, not used for shipboard installations, and located above the resilient mounts. The contracting activity will specify whether a mounting fixture is required (see 6.3). Those items requiring attachment to a mounting fixture shall be attached at the normal points of attachment of the equipment. The fixture shall be stiff between points of attachment and shall not have a natural frequency within ± 0.4 times the fundamental rotational frequency or other primary forcing frequency of the machinery or equipment. In addition, they shall not have natural frequencies within 0.4 times other machinery or equipment exciting frequencies between 0 and 500 Hz. If the equipment being measured contains internal sound isolation mounts, the mass of the fixture shall be great enough to permit these internal mounts to function properly. The mass of the fixture shall not exceed 30% of the total mass of the equipment. For equipment whose mass exceeds 900 kg, the mounting fixture of Figure 5-5 is recommended. Equipment items should be bolted directly to the fixture; however, the optional mounting pads and clamps shown on Figure 5-5 may be used to attach the items. If in specific cases, the mounting fixture of Figure 5-5 cannot be used, the alternative mounting fixture shall be approved by the contracting activity. The combined assembly of equipment item and mounting fixture shall be resiliently mounted and oriented so that the item is in its normal shipboard installation position.

5.6 Calibration of instrumentation. Before use, instrumentation shall be calibrated and meet the requirements specified herein.

5.6.1 Laboratory calibration. A laboratory calibration shall be made of all sound measuring instrument components within 12 months prior to each use, after exposure to mechanical shock or other unusual disturbing conditions, or upon request by the Government inspector. Calibration instrumentation, including the sound level calibrator used for field calibration (see 5.6.3), shall have a calibration within 6 months prior to each use traceable to the National Institute for Standards and Technology. The laboratory calibration of components shall be accurate within the instrument manufacturer's specification or ± 1 dB, whichever is more stringent.

5.6.1.1 Microphone calibration. Calibration of microphones shall be performed by one of the methods specified in ANSI S1.10. When secondary microphones are used, they shall be kept

MIL-STD-1474D

under controlled conditions in the equipment manufacturer's laboratory and used only for calibrating the microphones used for equipment measurements.

5.6.2 Electrical calibration for airborne sound measuring system. A calibration of each complete airborne sound measuring system including, but not limited to, microphone or simulated microphone, preamplifier, amplifiers, meter, analyzer, level recorder or plotter, and magnetic tape recorder, as applicable, shall be made by introducing known voltages and frequencies in series with the transducers. Cables and connectors shall have the same electrical characteristics (e.g., impedance, frequency response, capacitance) as those used during equipment measurement. Whenever any component of the measuring system is changed, a laboratory calibration shall be performed for the new component, and an electrical calibration shall be made with the new component in the system. System calibration shall ensure accuracy within ± 1 dB.

5.6.2.1 Frequency response. Known voltages at known frequencies shall be introduced into the system such as to simulate the microphone output, and the level shall be recorded. The frequencies selected shall be as follows:

- a. for analyzers with fixed filter sets, the band-center frequency of each filter in the specified frequency range.
- b. for analyzers with tunable filter sets used to scan continuously a band of frequencies, the lower limit, upper limit, and at least two intermediate frequencies (including 500 Hz if within the scanning range) in each frequency range scanned.

5.6.2.2 Linearity calibration. At a low frequency, at 500 Hz, and at a high frequency, calibration shall be made at the voltages equal to the microphone output that represents the

- a. lowest acceptance level for the applicable equipment specifications, and
- b. highest acceptance level for the applicable equipment specifications.

5.6. Field calibration. Total system calibrations, using a sound level calibrator or equivalent, shall be performed for each instrument configuration used in making the required measurements. These calibrations shall consist, as a minimum, of a single frequency at a known sound pressure level being introduced into the microphone from a sound source and adjustment of the system so that the system readout, i.e., the meter or recorder indicates the proper sound pressure level. A-weighting will make the proper sound level different from the calibrator sound level. When calibrating the peak measuring circuit, the indicated sound level shall be 3 dB higher than the rms level coming from the sound source. Field calibration of the total system shall be performed for each instrument configuration prior to its use in making a particular type of measurement, i.e., calibrate prior to LA and LC measurements, prior to octave band measurements, and prior to peak A-weighted sound pressure level measurements. Each instrument configuration shall be field calibrated prior to its use each day. Whenever any component of the measuring system is changed, a field calibration shall be made with the new component in the system. If the usual instrument settings and small adjustments do not produce the proper sound level indication during calibration, this normally indicates a problem which must be corrected prior to use of the instrument system. Field calibration shall be accurate within ± 2 dB.

5.7 Equipment operation conditions during measurements. Equipment operating conditions shall be as specified herein and in the contract or order (see 6.3).

5.7.1 Normal conditions. Equipment shall be operated under normal energized operating conditions including sufficient warmup time to reach normal operating temperature. Multiple speed equipment shall be measured at each operating speed. Variable speed equipment shall be operated

MIL-STD-1474D

at maximum, 1/2, and minimum speed (5% of maximum if equipment can be operated down to zero speed). Equipment pumps and fans shall be operating during measurements. Where equipment operates as a result of a signal, a representative signal shall be used to energize the equipment during measurements. Background measurements shall be made with the equipment not operating for each microphone and location under the normal environmental conditions that will be present when the equipment noise measurements are obtained.

5.7.2 Special operating conditions. If operating conditions other than those specified in 5.7.1 are required (see 6.3), such as during change of operating mode, including starting and stopping of the equipment, these special requirements shall be specified in the equipment specifications.

5.8 Selection of units. Unless otherwise specified (see 6.3), measurements to determine compliance with airborne acceptance criteria shall be made on every noise-emitting equipment item with the following exception: For nonrotating, nonreciprocating equipment, if the first three items of a design are below the criteria by 10 dB or more at all frequencies, the following items shall be selected for test in accordance with the sampling procedures for the applicable selective testing as specified in the equipment specifications.

5.9 Warning plate. Equipment that meets the criteria of this Requirement shall be prominently identified with a warning plate bearing the legend, "Quiet Design Equipment - Handle with Extreme Care." The plate shall be either type A or B of MIL-P-15024. Unless otherwise specified (see 6.3), the requirement applies only to rotating and reciprocating equipment.

5.10 Drawing and manual information. In addition to the information required on drawings by the applicable equipment specification, the assembly drawings shall contain specific notes as to assembly procedures and tolerances to be maintained during overhaul so that machines may be restored to designed level of quietness. Maintenance information pertinent to quietness, including assembly techniques and procedures, shall be included in technical manuals required by the acquisition documents. The title block of assembly drawings of all electrical power equipment shall include the words, "Special Quiet Design (controller or transformer, etc.) MIL-STD-1474." Existing drawings are not required to be revised unless the drawings are required to be changed for other reasons.

6. Notes.

(This section contains information of a general or explanatory nature which may be helpful, but is not mandatory.)

6.1 Intended use. This Requirement is intended to prescribe equipment acquisition testing and certain warning plate requirements and drawing and manual information requirements for shipboard equipment (see 5.10 and 5.11).

6.2 Associated Data-Item-Descriptions (DIDs). This standard is cited in DoD 5010.12L, Acquisition Management Systems and Data Requirements Control List (AMSDL), as the source document for the following DIDs. When it is necessary to obtain the data, the DIDs must be listed on the Contract Data Requirements List (DD Form 1423) except where the DoD Federal Acquisition Regulation Supplement exempts the requirement for a DD Form 1423.

<u>DID Number</u>	<u>DID Title</u>
DI-HFAC-80270A	Equipment Airborne Sound Measurement Plan
DI-HFAC-80271A	Sound Test Failure Notification and Recommendations Report
DI-HFAC-80272A	Equipment Airborne Sound Measurements Test Report

MIL-STD-1474D

The above DIDs were current as of the date of this Requirement. The current issue of the AMSDL must be researched to ensure that only the current and approved DIDs are cited on the DD Form 1423.

6.3 Details to be specified by the procuring activity. When this Requirement is invoked, the following should be specified:

a. The airborne sound acceptance criteria of Table 5-I are provided for guidance and use only when other criteria are not specified. (Either the criteria of Table 5-I or separate criteria should be specified.) When a large number of sources of small size are to be located within 2 m of each other, lower criteria will apply and should be based on the following correction factors. These correction factors are cumulative.

<u>Number of sources</u>	<u>Correction to be subtracted from the values shown in table 5-I</u>
2 to 8	3 dB
9 to 14	5 dB
15 to 22	7 dB
23 and up	9 dB

When the sources are within 2 meters of one another, e.g., electronic equipment in racks, subtract 3 dB.

Acceptance criteria will be based on the design of the machinery and consideration of intended service, overall ship operational requirements, and prior experience with similar acceptable machinery.

- b. Sampling procedures for equipment when sampling is desired (see 4.1).
- c. If an equipment plan is required (see 4.2).
- d. Whether the Government is to be notified of testing, and if so, which organization is to be notified and how long the advance notice time is to be (see 4.3).
- e. The grade assigned to the equipment (see 5.1).
- f. Whether the Government is to be notified of failure, and if so, which organization is to be notified (see 5.1(a)).
- g. Measurement locations if they deviate from 5.2.2 and 5.3.
- h. Measurement procedures and instrumentation if they deviate from 5.2.3.
- i. The frequency range for octave band measurements if other than 31.5 through 8000 Hz bands are desired (see 5.2.3.2).
- j. Whether there is an operator position for the equipment and, if so, the specific location of the operator's head (see 5.3).
- k. Mounting methods if they deviate from 5.5.
- l. The weight of the shipboard bedplate (see 5.5.1).

MIL-STD-1474D

- m. Whether a mounting fixture is required (see 5.5.2).
- n. Special equipment operating conditions during airborne sound measurements (see 5.7 and 5.7.2) if operating conditions other than the normal full load conditions are desired.
- o. Whether an alternate selection of units plan is to be used and, if so, what the plan is to be (see 5.8).
- p. If a test report is required (see 5.9).
- q. Whether a warning plate is required for nonrotating or nonreciprocating equipment (see 5.10).
- r. Technical proposal, if required (see 6.4).

6.4 Technical proposals. When this Requirement is invoked in acquisitions which require technical proposals for evaluation, the following data should be included in these proposals:

- a. A list of recommended specification changes which will improve the quietness of equipment and assure meeting the acceptance criteria. An estimate of the amount of improvement in quietness and the change, if any, in other characteristics should accompany each proposed change to the equipment specification.
- b. Outline of the facilities proposed for installation to comply with the requirements of the equipment specifications.
- c. A list of features to be incorporated in the equipment design for reduction of airborne sound levels.
- d. A list of actions that will be taken to assure achievement of specified sound levels.

6.5 Grade equivalency. There is no direct comparison between the criteria in this Requirement and those of MIL-STD-740B as these are expressed in terms of sound pressure level (re 20 μ Pa), while in 740B sound power level (re 10^{-12} watts) was used. Since the time of MIL-STD-740B, noise grade A was divided into A3 and A12 and the criteria for noise grade D was lowered by approximately 6 dB. The changes were made to reflect OPNAVINST 9640.1 regarding permissible ship compartment levels. In addition, spectra shape was changed to more closely follow typical shipboard spectra causing the acceptance levels of low frequencies to be more stringent in the new version compared to 740B. Very approximate relationships are given below based on the following assumptions: (a) omnidirectional source, (b) equipment size approximately 1 m cube, and (c) room constant = 186M2 to infinity.

Category A3, 2 dB greater than 740B for category A
 Category A12, 3 dB less than 740B, category A
 Category B, 2 dB less than 740B, category B
 Category C, 3 dB noisier than 740B, category C
 Category D, 4 dB quieter than 740B, category D

MIL-STD-1474D

MEASUREMENT LOCATIONS FOR SMALL EQUIPMENT

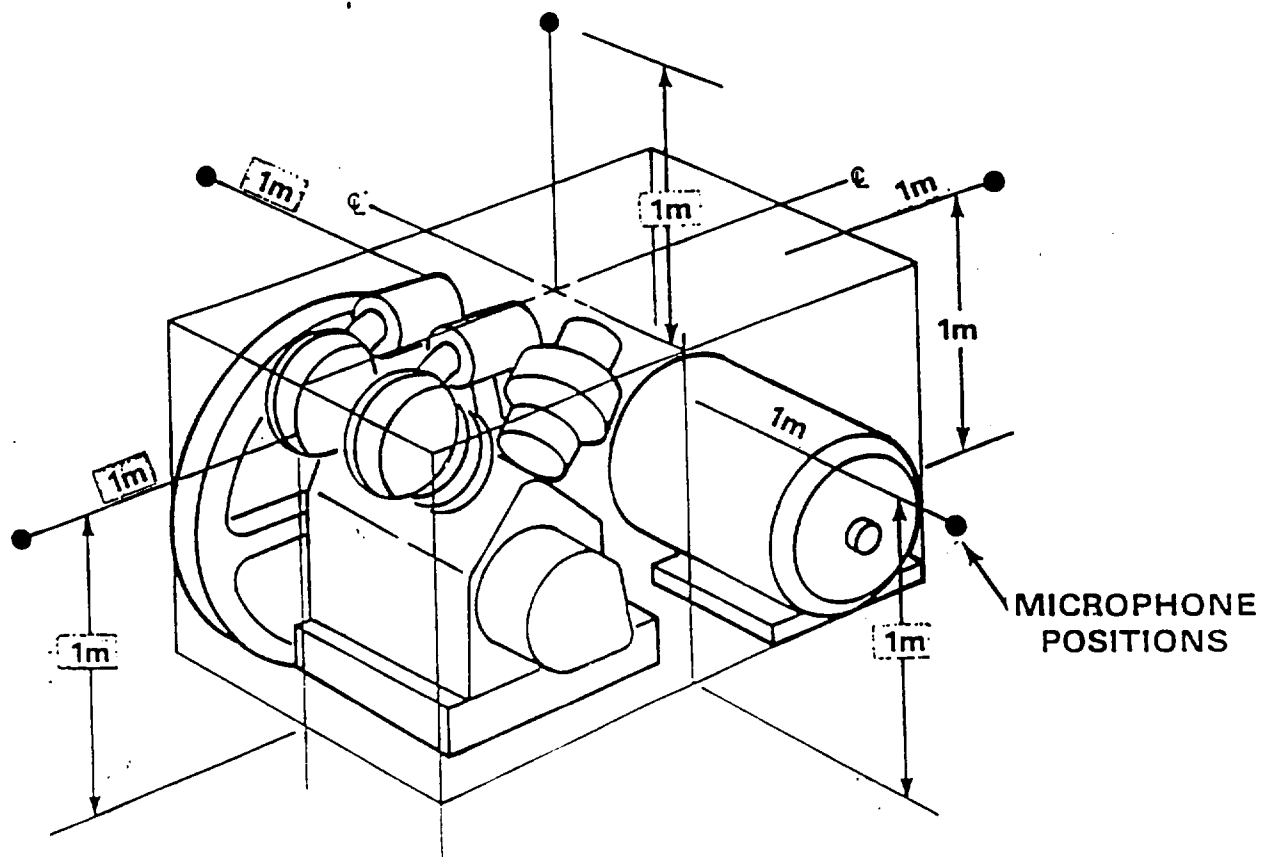

SH 131824

FIGURE 5-1. Sound measurement locations for small equipment, in addition to location of operator's head

MIL-STD-1474D

MEASUREMENT LOCATIONS FOR MEDIUM SIZE EQUIPMENT

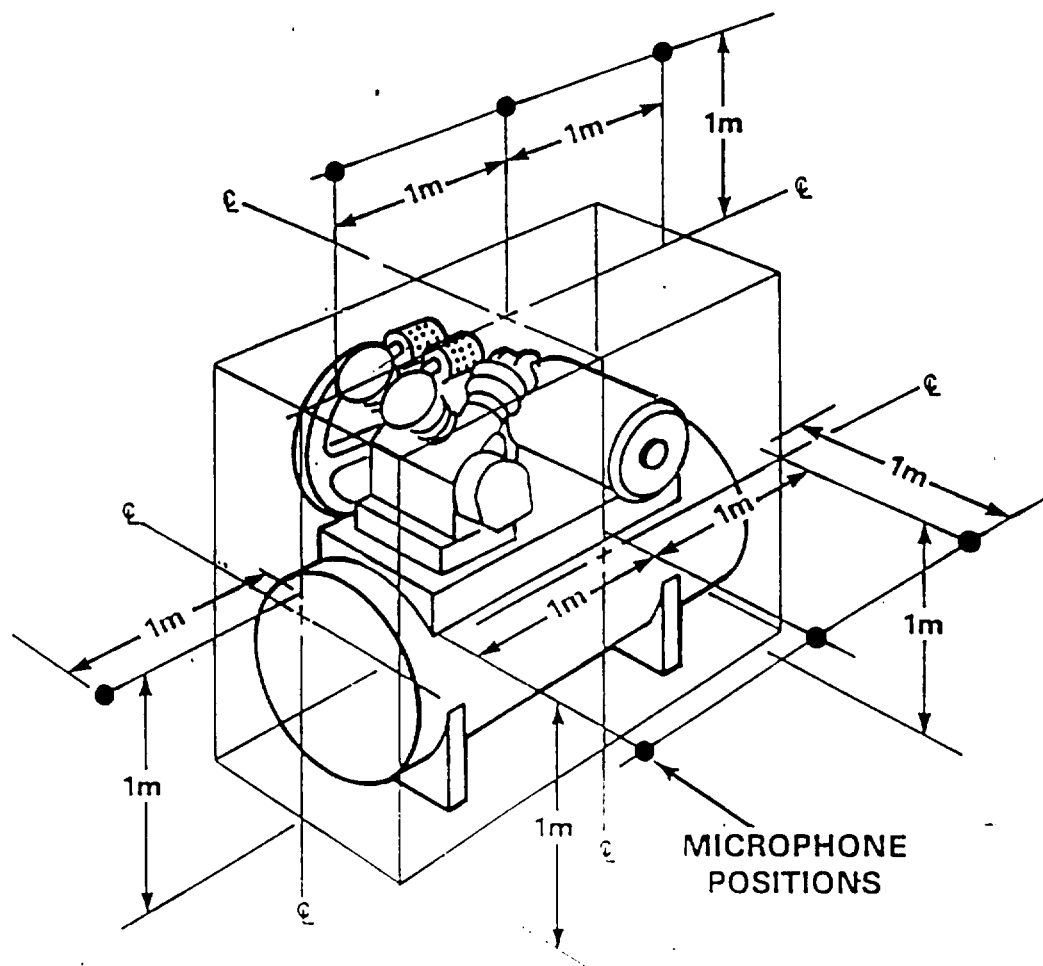

SH 131825

FIGURE 5-2. Sound measurement locations for medium size equipment, in addition to location of operator's head

MIL-STD-1474D

MEASUREMENT LOCATIONS FOR LARGE EQUIPMENT

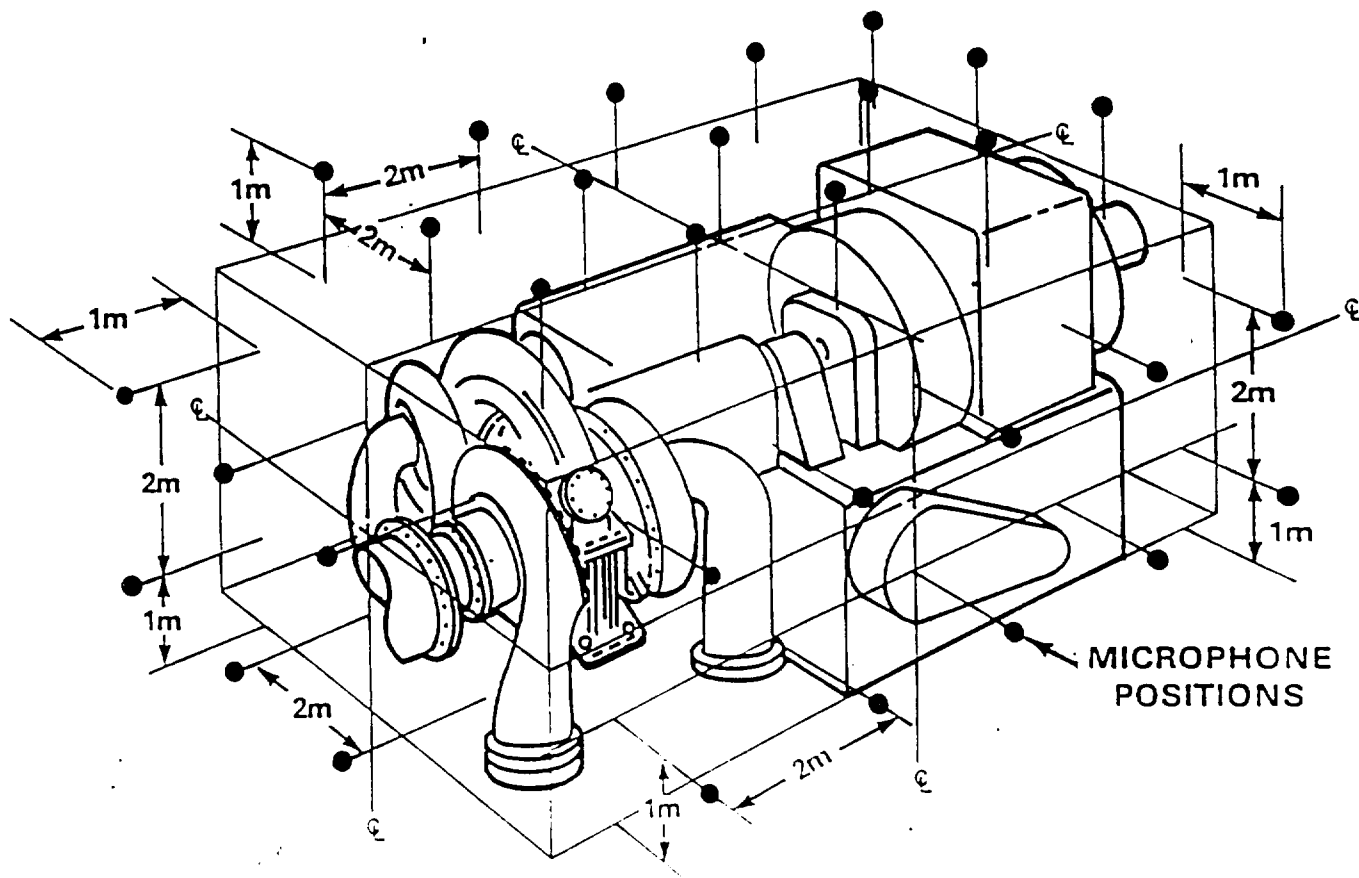

SH 131826

FIGURE 5-3. Sound measurement locations for large equipment

MIL-STD-1474D

MEASUREMENT LOCATIONS FOR VALVES

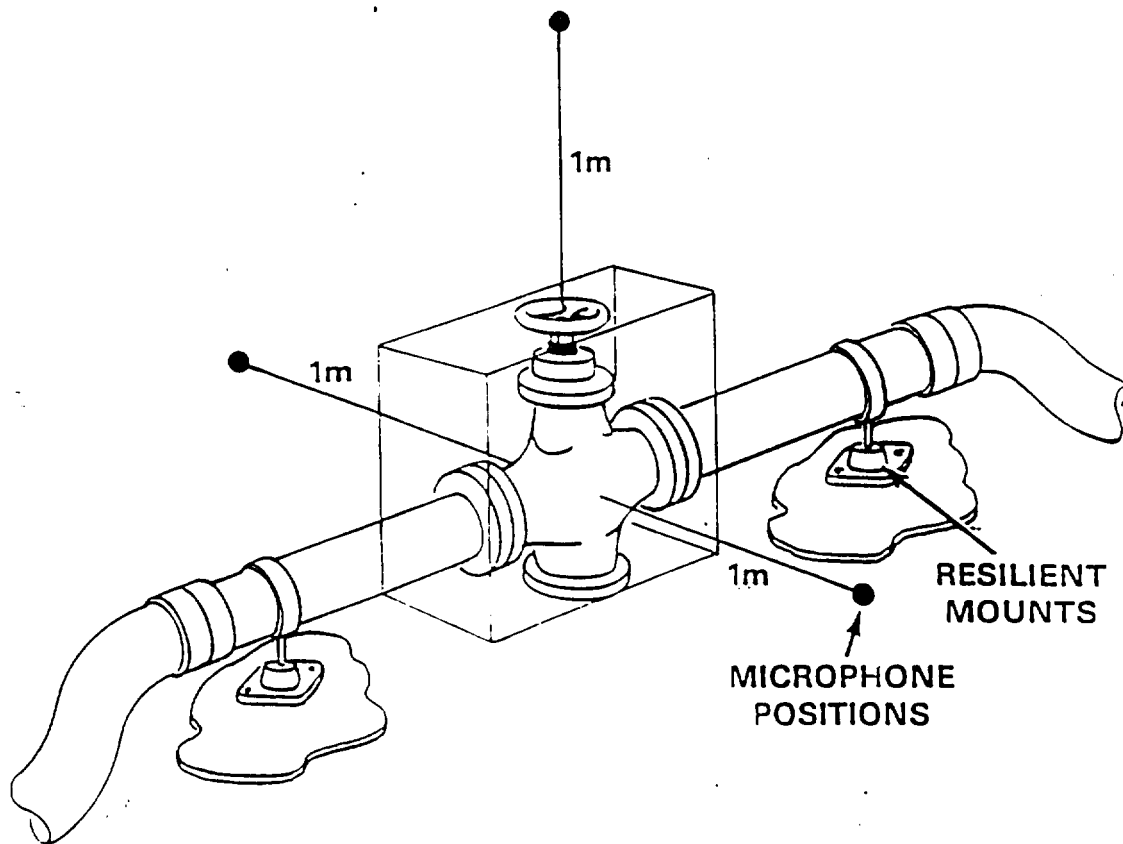

SH 131827

FIGURE 5-4. - Sound measurement locations for valves

MIL-STD-1474D

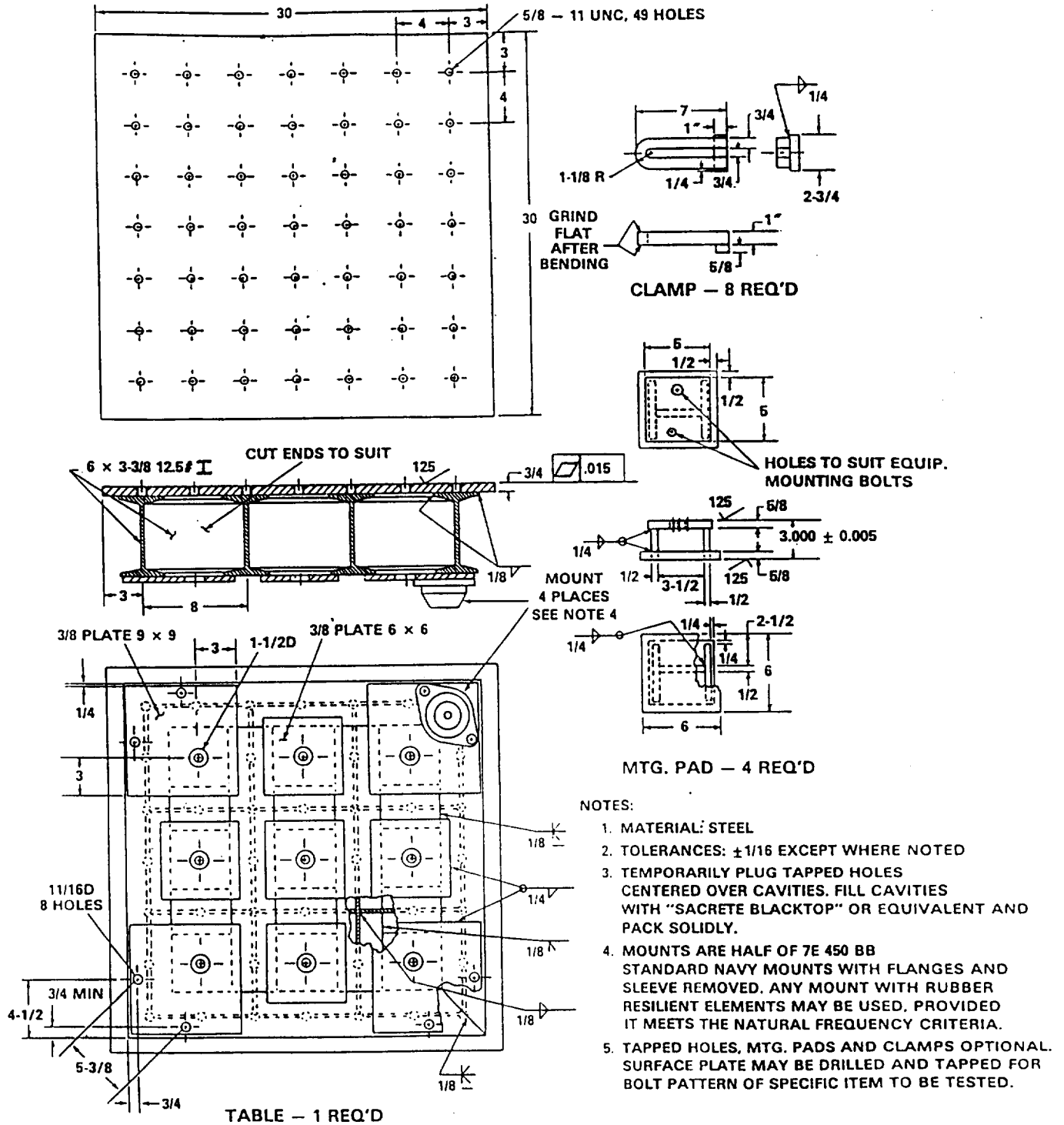

All dimensions are in inches

SH 131828

FIGURE 5-5. Standard text fixture

MIL-STD-1474D

REQUIREMENT 6

AIRCRAFT NOISE

1. Scope, applicability, and use.

1.1 Scope. This Requirement provides human engineering criteria for maximum allowable sound pressure levels in crew and passenger compartments. This Requirement also provides analysis and testing requirements for determining conformance to these criteria.

1.2 Applicability. This Requirement applies to fixed-wing aircraft. It also applies to rotary-wing aircraft developed by the U.S. Air Force.

1.3 Use. See 6.2.

2. Documents applicable to Requirement 6.

MIL-HDBK-1908	Definitions of Human Factors Terms
ANSI S1.1	Acoustical Terminology
ANSI S1.2	Physical Measurement of Sound, Method for
ANSI S1.4	Sound Level Meters, Specification for (DoD adopted)
ANSI S1.6	Preferred Frequencies and Band Numbers for Acoustical Measurements (DoD adopted)
ANSI S1.10	Calibration of Microphones, Method for the (DoD adopted)
ANSI S1.11	Octave-Band and Fractional-Octave-Band Analog and Digital Filters, Specification for (DoD adopted)
ANSI S3.5	Calculation of the Articulation Index, Methods for (DoD adopted)

(The above documents are cited either in this Requirement or in Sections 3, 4, or 5 of the basic standard. For applicability and ordering information, see preambles and addresses, respectively, in Section 2 of the basic standard.)

3. Definitions. Terms are defined in accordance with MIL-HDBK-1908. Terms not appearing below or in MIL-HDBK-1908 are defined in accordance with ANSI S1.1.

4. General Requirements.

4.1 Application. This Requirement is established for the _____ aircraft system to eliminate noise hazards and to provide effective aided and unaided communication for each flight member. Analytical techniques outlined shall be applied as early as possible in system development. Measurements shall be completed as early as possible during development of representative prototype and production aircraft so that necessary corrective action can be initiated in a timely manner.

4.2 Hearing damage criteria.

4.2.1 Time weighted average sound level. The 8-hour time weighted average equivalent sound level, shall not exceed 85 dB for any flight member based on aircraft usage and mission profiles given in ____ (a) _____. The total daily exposure selected in Table 6-I shall be based on flight members flying ____ (b) ____ missions in any given day. Hearing protection devices shall be worn as follows ____ (c) ____ (see Appendix B). This is also equivalent to summing the fractions of the actual time of exposure to the allowable time of exposure. If this value exceeds

MIL-STD-1474D

one, the combined exposure shall then be considered to exceed the standard. This is expressed mathematically as:

$$\frac{C_1}{T_1} + \frac{C_2}{T_2} + \frac{C_3}{T_3} + \dots + \frac{C_n}{T_n} > 1.0$$

where the C values are the times of exposure to a given level and the T values are the times allowed at those levels by Table 6-I. All noise exposures above the threshold of 80 dBA shall be used in the above equation.

Table 6-I. Noise limits for unprotected exposures

Time (minutes) ¹	Max Sound Level (dBA) ²	Time (minutes)	Max Sound Level (dBA) ²	Time (minutes)	Max Sound Level (dBA) ²
No Limit	<80	95	92	4.7	105
1440	80	76	93	3.8	106
1210	81	60	94	3.0	107
960	82	48	95	2.4	108
762	83	38	96	1.9	109
605	84	30	97	1.5	110
480	85	24	98	1.2	111
381	86	19	99	0.9	112
302	87	15	100	0.7	113
240	88	12	101	0.6	114
190	89	9.5	102	0.5	115
151	90	7.5	103		>115 forbidden
120	91	6.0	104		

¹Exposures of more than 12 hours are followed by periods of equal length in quiet (less than 72 dBA).

²The A-weighted sound level is used to assess hearing damage risk due to exposure to noise; for engineering noise control, other measures are required. The limiting duration of exposure at any noise level equal to or less than 115 dBA can also be determined from the equation:

$$\text{Time, T(minutes)} = 480 \times 2^{(85-L_A)/3}$$

where L_A = A-weighted sound level.

4.2.2 Noise exposure limits. Flight members shall not be exposed to continuous (non-impulsive) noise levels that exceed 115 dBA in the ear canal.

4.2.3 Whole body exposure limit. Flight members shall not be exposed to octave band levels exceeding 145 dB in the range 1 Hz through 40 kHz, regardless of hearing protection worn.

4.2.4 Frequency range. Total daily exposure and communication requirements shall be based on the third octave band center frequency range of 25 Hz to 20 kHz. Noise above this range shall not cause hearing damage to flight members.

MIL-STD-1474D

4.3 Government furnished equipment (GFE). The provisions of this Requirement shall apply to system noise levels including all GFE-produced noise.

4.4 Communications.

4.4.1 Modified Rhyme Test (MRT). MRT criteria shall apply to the following mission area communications equipment combination: _____. The scores on the MRT shall be not less than _____.

4.4.2 Articulation index (AI). AI criteria shall apply to flight member/mission area combinations as follows: _____.

4.4.3 Speech interference level (SIL). SILs are required for flight member/mission area as follows: _____.

4.5 Data collection.

4.5.1 Sound level measurements. Noise measurements shall be made on the first completely configured aircraft. When modifications may influence noise levels at flight member locations, additional noise measurements shall be taken.

4.5.2 Flight conditions. Noise measurements shall be made with the aircraft at the flight modes identified in the mission profiles of 4.2.1. All auxiliary systems used for each designated flight mode shall be in operation during the measurement.

4.5.3 Measurement locations. Noise measurements shall be made at the probable head locations of all flight members in all relevant mission areas. When possible, noise measurements shall be made with each flight member absent and at the center head location (80 cm above the seat at a standing height of 165 cm). During each measurement, the microphone should be oriented vertically with the diaphragm facing up and rotated in a 15 to 30 cm horizontal circle. Microphone location and orientation shall be subject to procuring activity approval.

4.5.4 Measurement information. The following information shall be recorded:

- a. The coordinates, stated numerically, and illustrated on an inboard profile or plan view of the aircraft.
- b. Whether the measurement location was occupied during measurement.
- c. Where a flight member has freedom of movement, mission area maximum minimum, and average noise levels.
- d. Where time variations in noise level may be significant, e.g., beats in propeller, noise data obtained for a period of time sufficient to define minimum and maximum levels.

4.5.5 Recording time. Each noise measurement shall be at least 30 seconds in duration.

4.5.6 Simulation/communication. A 60-second in-flight recording of the electrical noise in the communication system shall be made at a single key interconnection jack (e.g., pilot or co-pilot). The recording shall be made across an 8-ohm impedance connected to the headset lines, with the interphone volume control(s) set at maximum. Communication silence (no microphone keyed) shall be maintained during the period of recording. Actual recording shall be preceded and ended with a calibration tone (1000 Hz, 200 mW sinusoidal signal across 8-ohms).

MIL-STD-1474D

4.6 Instrumentation.4.6.1 Specifications.

4.6.1.1 Test instrumentation and procedures. Test instrumentation and procedures shall conform to ANSI S1.2, S1.4, S1.6, S1.10, and S1.11 unless otherwise specified.

4.6.1.2 Microphones. Microphones shall conform to ANSI S1.4.

4.6.1.3 Sound level meters. Sound level meters shall conform to requirements for Type 1, ANSI S1.4.

4.6.1.4 Octave band filter sets. Octave band filter sets shall conform to requirements for Order 3, Type 3-D, Extended Range, as specified by ANSI S1.11.

4.6.1.5 Tape recorders. Tape recorders shall meet the requirements of ANSI S6.1.

4.6.1.6 Other noise recording instrumentation. Other noise recording instrumentation or combinations of instrumentation shall conform to the applicable provisions of ANSI S1.4.

4.6.2 Calibration. Appropriate calibration procedures shall be followed for all tests. (See ANSI S1.10 for microphone calibration.)

4.6.3 Shielding and electrical isolation. Test instrumentation shall be electrically isolated (e.g., battery powered or powered by isolation transformers with noise filtering) from the aircraft electrical system to ensure that electrically induced noise is not included in acoustic measurements. Test instrumentation shall be adequately shielded to preclude the recording of erroneous data resulting from response of the instrumentation to operation of aircraft systems. Precautionary measures should be taken to prevent erroneous response of aircraft systems to the operation of acoustical instrumentation. An instrumentation baseline tape recording shall be made in flight with the microphone replaced by an equivalent shielded impedance.

4.6.4 Data analysis. All tape recorded data shall be analyzed in octave, third octave, and A-weighted sound levels. Analyses shall correct for frequency response of the measurement and analysis system.

5. Verifications.

5.1 Application. Verification shall be by inspection of contractor proposals to ensure proper and timely application of the requirements herein.

5.2 Hearing damage.

5.2.1 Time weighted average sound level. Verification shall be by analysis and test as follows: _____.

5.2.2 Noise exposure limits. Verification shall be by analysis of modeling data and measurement data generated by 5.2.1.

5.2.3 Whole body exposure. Verification shall be by analysis of modeling data and measurement data generated by 5.2.1 extended to 40 kHz.

MIL-STD-1474D

5.2.4 Frequency range. Verification shall be by evaluation of contractor test reports. Verification of sounds about 20 kHz shall be by: _____.

5.3 Government furnished equipment (GFE). Verification shall be by analysis of contractor plans and proposals.

5.4 Communications.

5.4.1 Modified rhyme test (MRT). An MRT shall be conducted for the flight member/mission areas specified in 4.4.1. The MRT shall be conducted in a noise field that simulates (in terms of frequency, intensity, and other characteristics such as beats) the actual aircraft noise at the member's position. MRT experimental design shall be verified as follows:_____.

5.4.2. Articulation index. Calculations shall be in accordance with the third octave band calculation method in ANSI S3.5. Ambient noise spectra shall be based on the modeling data generated by 5.2.1 or as measured noise spectra if available. The following method for calculating the AI shall be used:_____.

5.4.3 Speech interference level. Verification shall be by analysis of modeling and measurement data generated by 5.2.1.

5.5 Data collection.

5.5.1 Sound level measurements. Verification shall be by inspection of contractor test plans, ECPs, and other documentation.

5.5.2 Flight conditions. Verification shall be by inspection of test plans and test reports.

5.5.3 Measurement locations. Verification shall be by analysis of test plans and test reports.

5.5.4 Data acquisition. Verification shall be by inspection of test plans and test reports.

5.5.5 Recording time. Verification shall be by analysis of test plans, test reports, and data tapes.

5.5.6 Simulation/communication. Verification shall be by analysis of test plans and test reports.

5.6 Instrumentation. Verification shall be by inspection of test plans and test reports.

5.7 Noise level test reports. Verification shall be by inspection.

5.8 Data tapes. Verification shall be by inspection.

6. Notes.

(This section contains information of a general or explanatory nature which may be helpful, but is not mandatory.)

6.1 Intended use. This Requirement provides requirements and verification methods for sound pressure levels in manned USAF aircraft.

MIL-STD-1474D

6.2 Tailoring guidance for contractual application. This Requirement should be tailored to meet the specific sound pressure level needs of the identified aircraft. The Appendix provides rationale, guidance, and lessons learned for each requirement and verification to assist the tailoring process.

6.3 Use. This Requirement cannot be used for contractual purposes without supplemental information relating to operational need, configuration constraints, and information contained herein.

6.3.1 Structure. Supplemental information required is identified by blanks within the standard. A blank may be designated by the following symbol (n) and discussed as “Blank n.”

6.3.2 Handbook. Appendix A provides the rationale for requirements and guidance on Requirement usage.

MIL-STD-1474D

REQUIREMENT 7

ROTARY-WING AIRCRAFT NOISE

1. Scope, applicability, and purpose.

1.1 Scope. This Requirement establishes steady state acoustical noise limits within personnel occupied spaces of military helicopters. It provides general requirements for control of noise, prescribes testing requirements to verify conformance and to assess personnel safety and communications, and describes data analysis and reporting requirements.

1.2 Applicability This Requirement applies to the design of all systems, subsystems, component hardware, and equipment which can contribute to the noise within the occupied areas of the helicopter during its operation and maintenance. (Impulse noise limits for helicopters are defined in Requirement 4 of this standard).

1.3 Intended use. This Requirement is intended to provide the baseline by which the developer as well as the user of the helicopter can establish realistic noise control during development, testing, and operation of helicopters.

1.4 Purpose. Adherence to the provisions of this Requirement is intended to:

a. minimize hearing loss among personnel exposed to helicopter noise and near-field exterior noise at maintenance/service locations around the helicopter,

b. improve both aided and unaided speech communication in the noise environment of military helicopter compartments,

c. optimize aircraft performance, costs, and weight tradeoffs relating to acoustical treatments applied within military helicopters, and

d. standardize the methods of testing, verifying, and documenting of noise control within helicopters.

2. Documents applicable to Requirement 7:

MIL-HDBK-1473	Color and Marking of Army Materiel
MIL-HDBK-1908	Definitions of Human Factors Terms
ANSI S1.1	Acoustical Terminology
ANSI S1.4	Sound Level Meters, Specification for (DoD adopted)
ANSI S1.11	Octave-Band and Fractional-Octave-Band Analog and Digital Filters, Specification for (DoD adopted)
ANSI S1.13	Sound Pressure Level, Method for Measurement of (DoD adopted)
ANSI S3.5	Articulation Index, Method for the Calculation of the (DoD adopted)
ANSI S6.1	Qualifying a Sound Data Acquisition System, Recommended Practice

(The above documents are cited either in this Requirement or in Sections 3, 4, or 5 of the basic standard. Application for copies should be sent to the addresses shown in Section 2 of the basic standard.)

3. Definitions. Terms are defined in accordance with MIL-HDBK-1908. Terms not appearing in MIL-HDBK-1908 are defined in accordance with ANSI S1.1.

MIL-STD-1474D

4. General Requirements

4.1 Total system noise.

4.1.1 Subsystems. All aircraft subsystems which are to be normally operated in flight continuously for more than five (5) minutes per hour shall be selected and integrated so that the noise produced by the entire system in flight does not exceed the limits of this Requirement. Aircraft subsystems shall include, but not be limited to, the rotor(s), drive train, on-board auxiliary power unit (APU), and accessory equipment such as environmental control units, hydraulic pump systems, blowers, and fans.

4.1.2 Other on-board installations. Other noise generating sources include fluid flow devices (e.g., duct noise), electrical/electronic equipment (e.g., induction noise), and non-moving items that can be mechanically induced to vibrate.

4.1.3 Government furnished equipment (GFE). The fact that a subsystem or component which contributes to the internal sound levels may be GFE shall not eliminate the requirement that the total system noise conform to this Requirement. Where required, acoustic information on such systems shall be obtained from the procuring activity.

4.1.4 Ground operations. APUs shall be installed and located to minimize exposure of personnel to hazardous noise levels during maintenance and ground operations. Where applicable, additional acoustic treatment, which can be removed prior to flight, should be provided.

4.2 Posting of internal noise hazard areas.

4.2.1 General. When steady state noise levels are 85 dBA or greater, regardless of exposure time, or when impulse noise exceeds 140 dB peak pressure level at any personnel occupied areas (in flight or during ground operations and maintenance), caution signs shall be prominently and permanently posted and the appropriate manuals shall contain a prominent warning, followed by a discussion of the hazard.

4.2.2 Hazard signs (interior). Hazard signs shall be located so they are visible and legible to all passengers who are normally not required to wear aviation helmets or headphones. The signs may be printed on adhesive back labels for application to hard, smooth surfaces, or stenciled on fabric liners or acoustic blankets. The size, color coding, and wording of labels shall conform to Figure 1 of the basic standard. The size, color coding, and wording of stencils shall conform to Figure 7-1. Generally, noise areas with levels above 100 dBA or 140 dBP should be posted with danger signs per Figure 7-1A. Areas with levels of 85 to 100 dBA should be posted with caution signs per Figure 7-1B.

4.2.3 Manuals. Operation and maintenance manuals (e.g., field manuals, technical manuals) shall contain warning or caution notices to identify and highlight the harm resulting from excessive noise levels. In addition, manuals shall contain a discussion of the noise hazard including the requirement for hearing protection and the need for personnel to participate in a required hearing conservation program. This discussion shall include the requirement for wearing the aircrew helmet or other appropriate hearing protection. When applicable, it should also emphasize that wearing earplugs under the helmet will improve intelligibility and attenuation characteristics.

MIL-STD-1474D

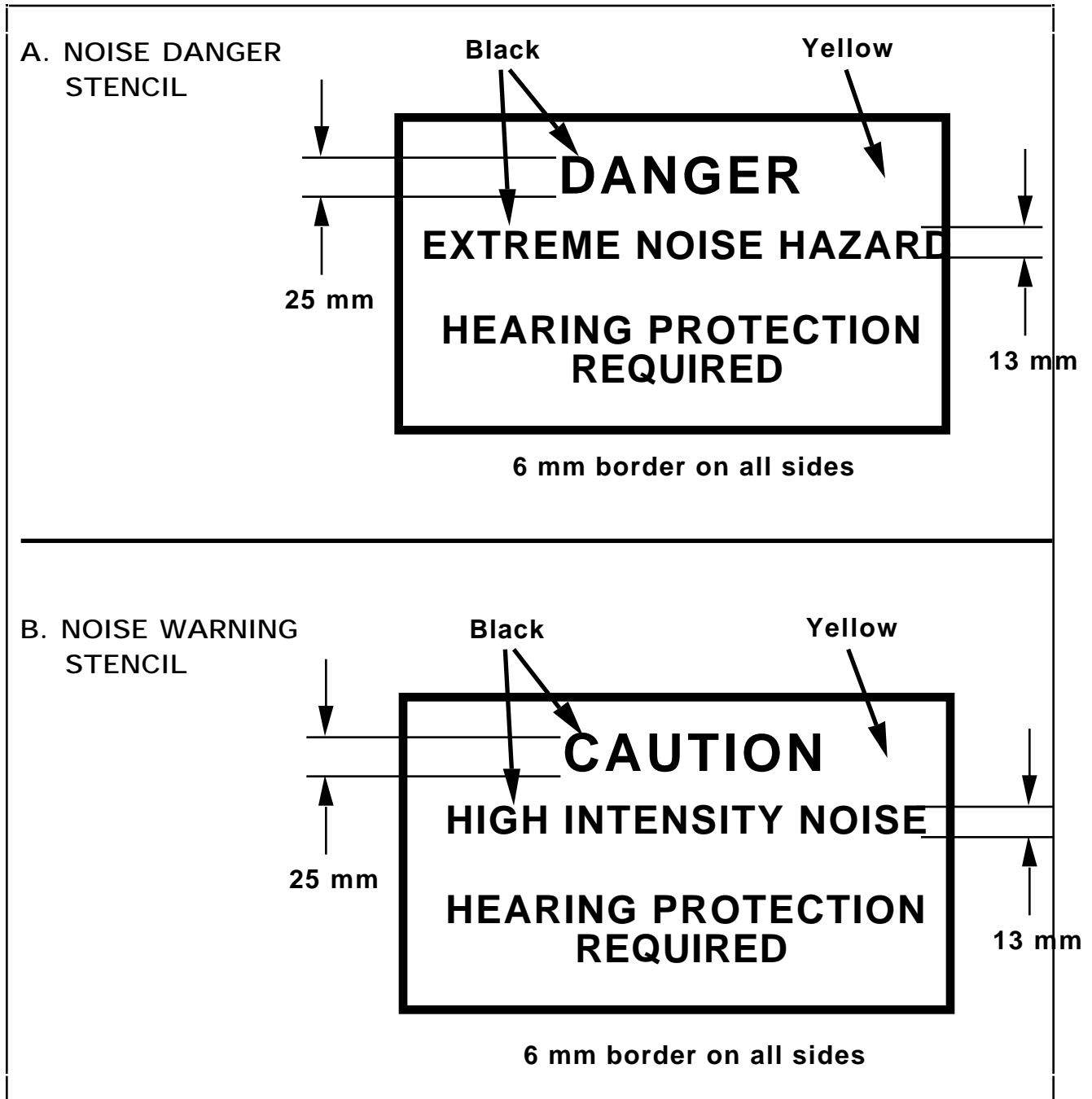
FIGURE 7-1. Size and wording of stencil

MIL-STD-1474D

5. Detailed Requirements.

5.1 Noise limit design criteria. Table 7-I presents the sound pressure levels that shall not be exceeded when measured in accordance with 5.2. Steady-state noise in helicopters with a design gross weight less than 9070 kg shall not exceed the levels of design limit A. Steady-state noise in helicopters with a design gross weight equal to or greater than 9070 kg shall not exceed the levels of design limit B. Where compliance with the levels of Column B can be documented as placing unacceptable penalties on aircraft performance and/or cost, the procuring activity may, after reviewing the adequacy of hearing protectors to be used in conjunction with sound insulation installation for the benefit of hearing conservation, permit the extension of the levels of Column B to the extreme levels of design limit C.

TABLE 7-I. Helicopter Sound Pressure Level (dB) design limits

OCTAVE BAND CENTER FREQUENCY (Hz)	DESIGN GROSS WT. 76 LESS THAN 9070 KG	DESIGN GROSS WT. 9070 KG OR GREATER	
	DESIGN LIMIT A	DESIGN LIMIT B	DESIGN LIMIT C ¹
63	116	116	116
125	106	106	110
250	99	99	103
500	91	93	97
1000	87	90	94
2000	82	89	93
4000	80	89	93
8000	85	91	95
16000	89	95	99

¹ Verifiable justification must be provided to the procuring activity to use Design Limit C

5.2 Noise measurements. The following provisions define the noise level measurements, measurement techniques, and aircraft operating conditions which are to be used to measure the aircraft's internal noise for compliance with the limits of Table 7-I, above. These measurement techniques and operating conditions should be followed rigorously to ensure uniformity of measurement from one measurement facility to another, and from one aircraft configuration to another.

5.2.1 Measurement location. Measurements, with instrumentation as specified by 5.4, shall be made at:

- a. each flight crew station, and
- b. a representative number of mission crew or passenger stations, the number and locations to be approved by the procuring activity.

MIL-STD-1474D

5.2.2 Test sample. Noise measurements shall be performed on an adequate number of production configured helicopters as early as possible in the development cycle. The number of test helicopter(s) shall be determined jointly by the procuring activity and the contractor.

5.2.3 Operating conditions.

5.2.3.1 Flight conditions. Flight conditions shall include the following:

a. Hover in ground effect. The helicopter shall be flown at a height determined by a Z/D ratio of 0.4 ± 300 mm where:

Z = the height of the rotor above the ground, and
D = the main rotor diameter.

b. Level flight. At lower forward airspeed of either $0.9V_H$ or $0.9V_{NE}$ where:

V_H = Maximum horizontal velocity at maximum continuous power.
 V_{NE} = Velocity never exceeded.

5.2.3.2 Gross weight and rotor speed conditions. Noise measurements shall be made while the helicopter is in flight at maximum design gross weight and at normal $\pm 5\%$ of rated rotor speed.

5.2.3.3 Helicopter subsystems and equipment. The subsystem and equipment which are normally operated continuously for more than five (5) minutes per hour in flight shall be operating during flight noise data acquisition. The heater shall be operated unless an air conditioner is present and generates a higher sound pressure level (in dBA); then the air conditioner shall be operated. Where heaters and air conditioners may be operated at the same time (such as for humidity control) both shall be operated.

5.2.3.4 Helicopter configuration. The helicopter shall be operated with doors, windows, and vents closed, and acoustical/thermal insulation treatment (hereafter referred to only as acoustical treatment) intact and in place.

5.2.4 Data acquisition. All data collection shall include a tape recording of each noise sample.

5.2.4.1 Microphone locations. Noise measurements shall be made at or near the head positions of all crew stations and at a representative number of passenger stations. Whenever possible, noise measurements should be made with the crew member or passenger absent and at a center head location at a distance of 80 cm above the seat reference point or, if standing, at a height of 160 cm. If practicable during each measurement, the microphone shall be rotated horizontally in a 15 to 30 cm diameter circle with the microphone diaphragm facing up.

5.2.4.2 Recording time. The recording time of each noise data sample shall be sufficient to produce a continuous 30-second or longer record of analyzed data.

5.3 Noise measurement requirements for personnel safety and communications. The purpose of these measurements is to identify potential noise hazards to personnel operating, servicing, and maintaining the helicopter on the ground as well as in flight and to determine the effectiveness of electrically-aided and person-to-person voice communications while the helicopter and its subsystems and equipment are in full operation (see also 5.2.3.3). These measurements shall be completed as early as possible during development of prototype and production helicopters

MIL-STD-1474D

so that appropriate corrective action, if required, can be undertaken in a timely, cost-effective manner.

5.3.1 Communication noise. A 60-second in-flight recording of the electrical noise on the communication system shall be made at a single key helmet interconnection jack (e.g., pilot or co-pilot). The recording shall be made across an 8-ohm impedance connected to the headset lines, with the selected interphone volume control(s) set at maximum. Communication silence (no microphone keyed) shall be maintained during the period of recording. Recording shall be preceded by and ended with a calibration tone (1000 Hz, 200 mW, sinusoidal signal across 8 ohms).

5.3.2 Personnel safety.

5.3.2.1 Flight measurements. Using the data acquisition procedures of 5.2.4, measurements shall be made (other than the configuration described in 5.2.3.4) at selected crew and passenger stations as approved by the procuring activity. These measurements shall be made for the following conditions and aircraft configurations:

a. Doors and windows open, removable acoustic treatment in, and other operating conditions as specified in 5.2.3. NOTE: The maximum allowable forward airspeed for this condition may be less than that specified in 5.2.3.1.b.

b. Doors and windows closed, removable acoustic treatment out, and other operating conditions as specified in 5.2.3.

c. Doors and windows open, removable acoustic treatment out, and other operating conditions as specified in 5.2.3. NOTE: The maximum allowable forward airspeed for this condition may be less than that specified in 5.2.3.1.

d. Armament systems operating. Flight conditions, doors and window configuration, and acoustic treatment as applicable for service use of armaments. With each armament system operating alone, with more than one operating system in varying combinations, and with all systems operating simultaneously.

5.3.2.2 Ground measurements. Using the data acquisition procedures of 5.2.4, measurements shall be made at the head position at a representative number of normal maintenance locations, as approved by the procuring activity. These measurements shall be made with the aircraft on the ground. All subsystems which are normally operated during ground maintenance (e.g., generators, hydraulics, environmental control unit) shall be operating. Doors and windows shall be open. All acoustic treatments and access panels normally removed for maintenance shall be removed. Measurements shall be made under each of the following operating conditions.

a. Engines off, APU operating (if so equipped).

b. All engines operating with rotors turning at flight-idle rpm (minimum collective pitch), and the APU operating (if so equipped).

c. Same as b., above, but with rotors not turning, if the aircraft can be operated in such a manner.

5.3.2.3 85 dBA contour. Noise measurements shall be taken to define the 85 dBA contour line around the helicopter. The microphone shall be a nominal 165 cm above the ground. The helicopter shall be on the ground and operating as specified by 5.3.2.2.b. An on-site measurement using a Type 1 sound level meter conforming to ANSI S1.4 may be used instead of tape recording and subsequent analysis.

MIL-STD-1474D

5.4 Instrumentation.5.4.1 Specifications.

5.4.1.1 Microphones. Microphones shall conform to the requirements of ANSI S1.4. Other noise recording instrumentation or combinations of instrumentation shall conform to ANSI S6.1 and applicable provisions of ANSI S1.4.

5.4.1.2 Octave band filter sets. Octave band filter sets shall conform to requirements for Order 3, Type 3-D, Extended Range, as specified by ANSI S1.11.

5.4.1.3 One-third octave band filter sets. One-third octave band filter sets shall conform to requirements for Type E, Class III, as specified by ANSI S1.11.

5.4.1.4 Sound level meters. Sound level meters shall conform to requirements for Type 1, as specified by ANSI S1.4.

5.4.1.5 System response. System response shall be within the limits specified by ANSI S6.1.

5.4.1.6 Tape recorders. Tape recorders shall meet the requirements of ANSI S6.1

5.4.2 Calibration. Appropriate calibration procedures shall be followed for all tests.

5.4.3 Shielding and electrical isolation. Test instrumentation shall be electrically isolated (e.g., powered by batteries or isolation transformers) from the aircraft electrical system to ensure that electrically induced noise is not included in acoustic measurements. Test instrumentation shall be adequately shielded to preclude recording erroneous data resulting from spurious response of the instrumentation to radio transmitter activation of the normal operating aircraft electrical subsystems and devices. Precautionary measures should be taken to prevent erroneous response of the aircraft navigational system to on-board magnetic devices (e.g., tape recorders). A tape recording shall be made in flight with the microphone replaced by an equivalent shielded impedance to establish an instrumentation baseline.

5.5 Data analysis. All steady state noise data shall be analyzed in octave band, 1/3 octave band, and A-weighted and C-weighted sound pressure levels (slow meter response) for each of the measured stations and conditions defined in 5.2 and 5.3 for the frequency range of Table 7-I. If Requirement 4 of this standard is specified, all impulse noise data shall be analyzed in time history format suitable for comparison to impulse noise criteria.

6. Notes.

(This section contains information of a general or explanatory nature which may be helpful, but is not mandatory.)

6.1 Intended use. This Requirement is intended to provide the baseline by which the developer and user of military helicopters can establish realistic internal sound level control during development, testing, and operational phases of the total system. It is a design standard evolved from consideration of hearing damage risk, helicopter aircrew mission profile exposure, speech intelligibility, state-of-the-art helicopter noise reduction, and the helicopter weight, performance, and cost trade-offs of acoustical treatment. This standard is neither a hearing damage risk criterion nor a hearing conservation criterion.

MIL-STD-1474D

6.2 Application and background. To meet the provisions of this Requirement and not place undue restrictions on aircraft performance, state-of-the-art noise reduction practices shall be applied to the design of the helicopter and to the placement and general design of subsystems. The percentage of gross weight historically allocated to acoustic treatment of military helicopters ranges from 0.5% to 1.5%. It is anticipated, therefore, that the combination of source noise control measures and military type acoustic treatment will require about 1.0% of vehicle gross weight to meet the limits specified herein. It should be emphasized that experience to date has shown that noise source control measures generally provide more weight efficient design solutions than the utilization of acoustical barrier/absorptive materials alone. Source noise control measures include, but are not limited to, fuselage damping, gear and housing stiffness damping, gear and tooth profile control, tooth mesh phasing, low noise component selection, hydraulic pump selection and isolation, hydraulic line isolation, hydraulic system damping, and drive system dynamic control.

3. Rationale for limits. The allowable helicopter noise levels specified by this Requirement were established to represent a reasonable compromise between those levels which the current state-of-the-art permits the designer to achieve in helicopters with approximately 1% of gross vehicle weight (GVW) devoted to noise treatment, and those levels which would minimize hearing damage risk and maximize speech communication. The allowable levels will also ensure that the aided speech intelligibility provides an articulation index of at least 0.6. Helicopters below 9070 kg (GVW) are treated separately from those at 9070 kg and above because of the strong positive relation between internal noise levels and GVW. The design limit levels for helicopters under 9070 kg permit eight (8) hours of daily flight mission exposure for aircrew members wearing the SPH-3C, SPH-4, or HGU derivative aviator's helmet assemblies and six (6) hours for passengers using approved hearing protection. The design limit levels for helicopters over 9070 kg permit four (4) hours of daily flight mission exposure for aircrew members wearing the SPH-3C, SPH-4, or HGU derivative aviator's helmet assemblies and three (3) hours for passengers using approved hearing protection.

MIL-STD-1474D

APPENDIX A.

GUIDANCE FOR REQUIREMENT 6

A.1 SCOPE

A.1.1 Scope. Requirement 6 provides human engineering criteria for maximum allowable sound pressure levels in crew and passenger compartments of all fixed wing aircraft. It also applies to rotary wing aircraft developed by the U.S. Air Force. Requirement 6 also provides analysis and testing requirements for determining conformance to these criteria.

A.1.2 Purpose. This appendix provides the rationale for requirements, guidance on document usage, and lessons learned to serve as a basis for formulating the supplemental information of A.1.3, below.

A.1.3 Intended Use. Requirement 6 cannot be used for contractual purposes without supplemental information relating to operational need, configuration constraints, and information contained herein. Supplemental information required is identified by blanks within the standard. A blank may be designated by the following symbol _(n)_ and discussed as "Blank n."

A.2 APPLICABLE DOCUMENTS

A.2.1 General. The documents referenced in this appendix are not intended to be applied contractually. Their primary purpose is to provide background information for the Government engineers responsible for developing the most appropriate performance values (filling in the blanks) for the requirements contained in the specification proper.

A.2.2 Government documents. Not applicable.

A.2.3 Non-government publications.

AMERICAN NATIONAL STANDARDS INSTITUTE (ANSI)

ANSI S1.1 Acoustical Terminology (Including Mechanical Shock and Vibration)

ANSI S1.6 Preferred Frequencies and Band Numbers for Acoustical Measurements Criterion (DoD Adopted)

ANSI S3.14 Rating Noise with Respect to Speech Interference

(Requests for copies should be addressed to the American National Standards Institute, Inc., 1430 Broadway, New York, NY 10018)

A.3 DEFINITIONS. The definitions in Section 3 of this standard apply to this appendix.

A.4 REQUIREMENTS (Requirements, Requirement Rationale, Requirement Guidance, Verification Rationale, Verification Guidance and where applicable Requirement Lessons Learned)

4.1 Application. Requirement 6 establishes requirements for the _____ aircraft system to eliminate noise hazards and to provide effective aided and unaided communication for each flight member. Analytical techniques outlined shall be applied as early as possible in system development. Measurements shall be completed as early as possible during development

MIL-STD-1474D

of representative prototype and production aircraft so that necessary corrective action can be initiated in a timely manner.

REQUIREMENT RATIONALE (4.1)

The intent of this requirement is to identify the aircraft system and to emphasize the need for timely implementation of requirements contained herein.

REQUIREMENT GUIDANCE

Invoke this requirement for all systems. Identify the aircraft system in the blank (e.g., F-15, C-141, HH-60)

5.1 Verification of application. Verification shall be inspection of contractor proposals to ensure proper and timely application of the requirements for Requirement 6.

VERIFICATION RATIONALE (5.1)

An inspection is required to ensure that analytical and measurement requirements will be accomplished in an expedient manner.

VERIFICATION GUIDANCE

The Government human factors engineer (HFE) should carefully inspect the contractor's specifications, test plans, etc., to ensure that the requirements have been met.

4.2 Hearing damage criteria.4.2.1 Total daily exposure (TDE).

REQUIREMENT RATIONALE (4.2.1)

Acoustic TDE requirements provide a rational method for comparing varying noise environments with regard to permanent and temporary hearing damage potential. This requirement is based on the flight member's anticipated mission workday. Daily or frequent TDEs exceeding 1.0 may result in irreversible hearing damage to personnel. Single intense exposures to TDEs greater than 1.0 may result in temporary hearing threshold shifts. This requirement is based on the principle that all USAF aircraft have mission profiles defined prior to design service of the aircraft. Each mission profile is composed of specific mission segments, e.g., takeoff, landing, refueling. Each mission segment and associated noise exposure must be considered for each mission profile. This information will be included in the airframe specification or in the Airframe Structural Integrity Program master plan.

REQUIREMENT GUIDANCE

The first blank (a) should be filled by reference to the contractual usage and mission profiles. The appropriate document title and identification (including date and revision) should be entered. The next blank (b) should be completed by specifying the maximum number of missions which may be flown by individual flight members per day. If this varies, based on the specific mission mix, this information must be included. The personal hearing protection devices to be worn by flight members should be specified in the last blank (c). Information included shall be referenced to devices listed in Tables B-1 and B-2 in Appendix B or, when approved by the procuring activity, to detailed specifications for specific devices. When different devices are

MIL-STD-1474D

provided for different flight members (or mission areas) and when devices are not required at all times this information shall be included.

5.2.1 Verification of total daily exposure.

VERIFICATION RATIONALE (5.2.1)

Aircraft interior acoustic levels and thereby TDEs are directly related to propulsion system location and characteristics, airframe structural and environmental control system design, flight member locations, and aircraft flight conditions as well as acoustic treatment design and personal hearing protection devices. An integrated design analysis program encompassing all of these factors is required if TDE requirements are to be met for acceptable weight and cost.

VERIFICATION GUIDANCE

The verification guidance for this requirement is separated into analysis and measurement.

a. Analysis. Analysis of aircraft noise is based on data obtained from similar aircraft and equipment, propulsion system noise analysis, boundary layer turbulence analysis, acoustical properties of insulation, etc. These results should be utilized in flight member noise exposure analyses as early as possible during the design process. Analyses should include contributions of all auxiliary equipment ambient noise levels (e.g., air conditioning pumps, cooling fans). Analyses should be performed for each mission profile identified and for all flight members. The data produced by these analyses and subsequent measurements may be useful for making other design decisions relating to noise and its attenuation.

This part of the requirement may appear as follows:

a. Analysis. Analysis shall be conducted as early as possible and throughout the development of the aircraft to predict TDEs for each flight member. These analyses shall be conducted in conjunction with airframe structural and interior acoustic treatment design analyses. Analyses will be performed for the following flight member/mission areas:

- (1) Pilot* - tanker and passenger configurations
- (2) Co-pilot* - tanker and passenger configurations
- (3) Boom operator - tanker configuration only.

H-157 headset to be worn in boom pod only. Boom operator to occupy the pod during air refueling segments and crew rest area for remainder of flight. Calculations shall include noise produced by the air refueling pumps.

- (4) Passenger seats - passenger configuration only.

Passengers not required to wear headgear.

* Positions (1) and (2) (Pilot and Co-pilot) are to wear H-157 headgear throughout the entire flight.

An example of the single-seat fighter specification might read:

MIL-STD-1474D

a. Analyses. Analyses shall be conducted as early as possible and throughout the development of the aircraft to predict TDEs for the pilot wearing the HGU-26/P or 55/P helmet with H-154 liner. These analyses shall be conducted in conjunction with airframe structural and interior acoustic treatment design analyses. Analyses shall consider the noise produced by auxiliary equipment. This analysis shall result in an integrated design limited TDEs as specified herein at minimum weight and life cycle costs.

The hearing protection values given in Tables B-1 and B-2 of Appendix B are the hearing protection values expected for 97.7% of wearers. This table does not include every item in the inventory. Each service, has on file the noise attenuation characteristics of most headgear used within the service. This data is presented in various formats and may require some manipulation to be compatible with the analysis and measurement data.

b. Measurements. Measurement of actual noise levels is necessary to verify compliance with the requirement. Measurements shall be performed at the mission areas and flight conditions of the mission profiles. Using the tanker as an example, the second portion of the verification requirement might read as follows:

b. Measurement. Measurements shall be taken at the head position of flight member mission areas stated in 1.a. through 1.d. above.

4.2.2 Noise exposure limits.

REQUIREMENT RATIONALE (4.2.2)

The intent of this requirement is the protection of flight member hearing. Sound levels that exceed 115 dBA can damage human hearing and/or cause temporary threshold shifts.

REQUIREMENT GUIDANCE

This requirement should be invoked for all aircraft systems. This requirement establishes upper boundaries for protection of the operator from overexposures; it is to be used as a mandatory supplement to 4.2.1 but is not a replacement for that paragraph.

REQUIREMENT LESSONS LEARNED

Exposure to continuous noise levels at or above 115 dBA can result in a very rapid and severe hearing loss.

5.2.2 Verification of noise exposure limits. Verification shall be by analysis of modeling data and measurement data generated by 5.2.1.

VERIFICATION RATIONALE (5.2.2)

This requirement can ultimately be verified only by direct measurement. Spectral noise data generated by analysis must be examined early in system development to identify and resolve noise-related problems in a timely manner.

The data generated by 4.2.1 should be used for the verification of this requirement.

4.2.3 Whole body exposure limit. Flight members shall not be exposed to octave band levels exceeding 145 dB in the range 1 Hz through 40 kHz, regardless of hearing protection worn.

MIL-STD-1474D

REQUIREMENT RATIONALE (4.2.3)

At levels above 145 dB noise can have adverse effects not specific to hearing organs. These effects may include disorientation, nausea, and fatigue.

REQUIREMENT GUIDANCE

Invoke this requirement for all aircraft. Exposures to levels in excess of the specified dB levels are prohibited regardless of duration of exposure or hearing protection worn.

5.2.3 Verification of whole body exposure limit

VERIFICATION RATIONALE (5.2.3)

Analysis of modeling and measurement data is necessary to identify potentially harmful noise both within and outside the frequency range specified by 4.2.4 so that problematic sources can be identified in a timely manner. Additional measurements outside the frequency range specified by 4.2.4 are required if indicated by analysis results.

VERIFICATION GUIDANCE

Verification that no octave band exceeds 145 dB in the range of 20 Hz to 20 kHz is easily accomplished by inspection or analysis of the data generated by 5.2.1. It is unlikely that frequencies outside this range will contain sufficient energy to cause hearing damage; however, it is necessary to ascertain that such risk is minimal. A source of data for these extreme frequency ranges may be found in component engineering data. If frequencies outside the 20 Hz to 20 kHz range are suspect, measurements are required by 5.2.4.

4.2.4 Frequency range.

REQUIREMENT RATIONALE (4.2.4)

20 Hz to 20 kHz is the approximate frequency range of human auditory sensitivity and where adverse effects of noise may be observed on hearing and voice communications. Noise outside of this range is rarely of sufficient magnitude to cause damage to hearing. A secondary purpose is to standardize the frequency ranges measured to facilitate comparisons between aircraft. (See ANSI S1.6 for additional information about this frequency measurement.)

REQUIREMENT GUIDANCE

Invoke this requirement for all aircraft systems. Some analyses, e.g., Articulation Index, may be used on a more limited frequency range; however, it is important that measured data comply with this requirement. Discussion of frequencies outside the above ranges is contained in verification guidance below.

5.2.4 Verification of frequency range.

VERIFICATION RATIONALE (5.2.4)

Evaluation (inspection) of contractor test reports and data is sufficient for verification of this requirement.

MIL-STD-1474D

VERIFICATION GUIDANCE

Verification of the 20 Hz to 20 kHz requirements is straightforward requiring only inspection of appropriate documentation to ensure that the proper range is reported. It is unlikely that frequencies above 20 kHz will contain energy sufficient to damage hearing, however, octave bands with SPLs exceeding 90 dB should be measured and reported. If review of the system specification reveals equipment which may contribute to infra- or ultrasonic noise, require measurements of the suspect frequencies by filling in the blank. For example, suppose an aircraft contains ultrasonic medical equipment which will be used in flight. The last sentence should read: "Verification of sounds above 20 kHz shall be by analysis of measured data and biomedical reports to ensure that ultrasound generated by the medical equipment does not endanger the hearing of flight members."

4.3 Government furnished equipment (GFE).

REQUIREMENT RATIONALE (4.3)

Requirement 6 shall apply to system noise levels including all GFE-produced noise.

REQUIREMENTS GUIDANCE

Invoke this requirement for all aircraft systems. Noise characteristics of GFE may be available from government sources such as the equipment's responsible engineering office or from the manufacturer.

5.3 Verification of Government furnished equipment (GFE).

VERIFICATION RATIONALE (5.3)

Analysis of contractor plans and proposals is adequate to ensure compliance with this requirement.

VERIFICATION GUIDANCE

Verify that the contractor noise analyses consider all GFE listed in the system specification that might reasonably be expected to add to noise levels. Verify that measurements include operation of appropriate GFE items.

4.4 Communications.4.4.1 Modified Rhyme Test (MRT).

REQUIREMENT RATIONALE (4.4.1)

The use of Requirement 6 test criterion is necessary for the assessment of communication intelligibility in the presence of noise. This makes interaircraft comparisons possible and allows establishment of a data base for communications systems.

REQUIREMENT GUIDANCE

Invoke this requirement for all aircraft.

Fill in the first blank with definitions of the mission area, flight member, and communication equipment combinations.

MIL-STD-1474D

Fill in the second blank with appropriate criterion score in terms of a percentage quantity. This score may be obtained from Table I (other intermediate levels may be chosen) taking into consideration the following:

- a. Criticality of communications.
- b. Size and "stability" of the vocabulary involved (e.g., aircrews use standardized radio vocabularies.)
- c. The training of the communicators.
- d. The conditions under which communications will take place (e.g., combat).
- e. The types of tasks and task loading that the operator must accomplish during communication.
- f. Auditory distractions (such as verbal or tone warnings or status indications) which might be encountered during communications.

TABLE A-I. Intelligibility criteria for voice communications systems

COMMUNICATION REQUIREMENT	SCORE		
	PB	MRT	AI
Exceptionally high intelligibility; separate syllables understood	90%	97%	0.7
Normally acceptable intelligibility; about 98% of sentences correctly heard; single digits understood	75%	91%	0.5
Minimally acceptable intelligibility; limited standardized phrases understood; about 90% sentences correctly heard (not acceptable for operational equipment)	45%	75%	0.3

The criterion score should reflect the worst-case noise conditions, e.g., take off or climb out. At this time, no quantitative method exists for assessing the relative importance of each of these factors or the interaction among factors. Also, different criteria could apply to the same aircraft, depending on the functions of the differing systems. For example, a Presidential airlift aircraft might require one set of MRT criteria for the aircrew who have had extensive training in radio procedures and use a standardized vocabulary, and a different more stringent set of criteria for passenger VIPs for air-to-ground communications. The HFE must use the best available information to make an appropriate judgement. As a general rule, MRT scores of less than 70% are unacceptable for aircraft, and scores in the mid 70 range are minimally acceptable. Technical questions regarding experimental equipment procedures, or design should be directed to the service laboratory or branch responsible for acoustical noise.

MIL-STD-1474D

REQUIREMENT LESSONS LEARNED

The MRT measurement of speech intelligibility is an instrument which, unlike other techniques, can be used routinely by relatively naive talkers and listeners, (i.e., operational personnel) to estimate the condition of communication systems. However, formal evaluations of communications systems should be accomplished by experienced personnel to ensure that all assumptions and requirements of the MRT and its use are satisfied.

5.4.1 Verification of Modified Rhyme Test (MRT). An MRT shall be conducted for the flight member/mission areas specified in 4.4.1. The MRT shall be conducted in a noise field that simulates (in terms of frequency, intensity, and other characteristics such as beats) the actual aircraft noise at the flight member's position. MRT experimental design shall be verified as follows: _____.

VERIFICATION RATIONALE (5.4.1)

Analysis of contractor test plans, methods, and results may suffice for verification. If the contractor does not have the necessary equipment or personnel to satisfactorily accomplish testing, government tests may be required.

VERIFICATION GUIDANCE

At this time, only a limited number of contractors have facilities available for MRT testing. Several manufacturers of communications equipment have facilities for Diagnostics Rhyme Test (DRT). However, the DRT is not an acceptable alternative to the MRT for this standard. Request for Proposal (RFP) respondents have the option of performing in-house testing or contracting for government or subcontractor testing.

Test plans and conduct should be carefully scrutinized to assure that the test objectives are met. Request specific information on test procedures. As in any experiment conducted using human subjects, the results of the MRT can be biased or distorted by seemingly insignificant flaws in experimental design or technique. Thus it is important not to accept test proposals that lack detail. A discussion of proper experimental design and technique is beyond the scope of this document; however, various service laboratories have employees with training and experience in human performance assessment. Direct observation of the contractor's testing may be required to verify compliance.

4.4.2 Articulation index (AI). AI criteria shall apply to flight members/mission area combinations as follows: _____.

REQUIREMENT RATIONALE (4.4.2)

AI is a predictive technique for the assessment of communications intelligibility. Prediction may be necessary to ensure that potential communications system intelligibility problems are identified and resolved in a timely, cost effective manner.

This requirement is an optional supplement to the MRT, 4.4.1. It should be used in all cases where it is questionable whether the criteria specified in the MRT requirement will be met. The MRT requires use of the actual communications equipment, and requires tape recordings of the actual ambient noise. As such, the MRT intelligibility requirements cannot be verified until late in the design process, i.e., after prototypes of the equipment are available. AI may be useful for predicting problems early in the design process so that these problems can be resolved at low expense before prototyping. The AI is not, however, to be used as a replacement for the MRT.

MIL-STD-1474D

Before waiving this requirement, one should consider the following: The underlying intent of this requirement is to "force" timely design consideration of speech intelligibility at system levels. If the system is obviously adequate, the requirement may be redundant with the MRT. On the other hand, if the system is questionable in any respect, the cost effectiveness of this requirement can be quite high.

REQUIREMENT GUIDANCE

Enter the crew station/communication equipment combinations to be considered in the blank. The wording of this requirement should be similar to that of a 4.4.1 MRT. For example, the requirement for a two seat aircraft might read: "AI criteria shall apply to meet crew station/communications equipment as follows: Pilot/copilot - UHF and VHF AI shall equal or exceed 0.5; Interphone AI shall equal or exceed 0.3." Use Table I to transpose the MRT scores to the appropriate AI score. Figure A-1 may also be used for guidance.

5.4.2 Verification of articulation index. Calculations shall be in accordance with the third octave band calculation method in ANSI S3.5. Ambient noise spectra shall be based on the modeling data generated by 5.2.1 or on measured noise spectra if available. The following method for calculating the AI shall be used: _____.

VERIFICATION RATIONALE (5.4.2)

The AI is an analytical method based (usually) on estimated noise and communication equipment data. As such, analysis is the only method of verification.

VERIFICATION GUIDANCE

Three methods for calculating the AI are available: (1) the 20 band method, (2) the third octave band method, and (3) the octave band method. Using the 20 band method in situations where a high degree of sensitivity is required or where an appreciable fraction of the energy of the masking noise is concentrated in frequency bands one octave or less in width, or where the communications system has significant distortion. The third octave band method is slightly less sensitive, but has the advantage that the modeling data generated by 4.2, are in third octave band form. The octave band method is less sensitive than the 20 band method but is slightly easier to calculate.

The appropriate method for calculation should be entered into the blank, or the procuring activity may opt to let the contractor choose the appropriate method, in which case the sentence containing this blank is deleted.

4.4.3 Speech interference level (SIL). SILs are required for flight member/mission areas as follows: _____.

REQUIREMENT RATIONALE (4.4.3)

Speech interference levels help assure that face-to-face speech communications necessary to mission performances are of adequate intelligibility.

Applicability. There are many situations in aircraft missions in which highly intelligible face-to-face communications are imperative to mission success. For example, some systems may require face-to-face communications among flight members. Pilots in side-by-side seating arrangements often communicate without using the intercom. Effective communications might not be critical but highly desirable. For example, passengers in an executive-type aircraft may need to conduct

MIL-STD-1474D

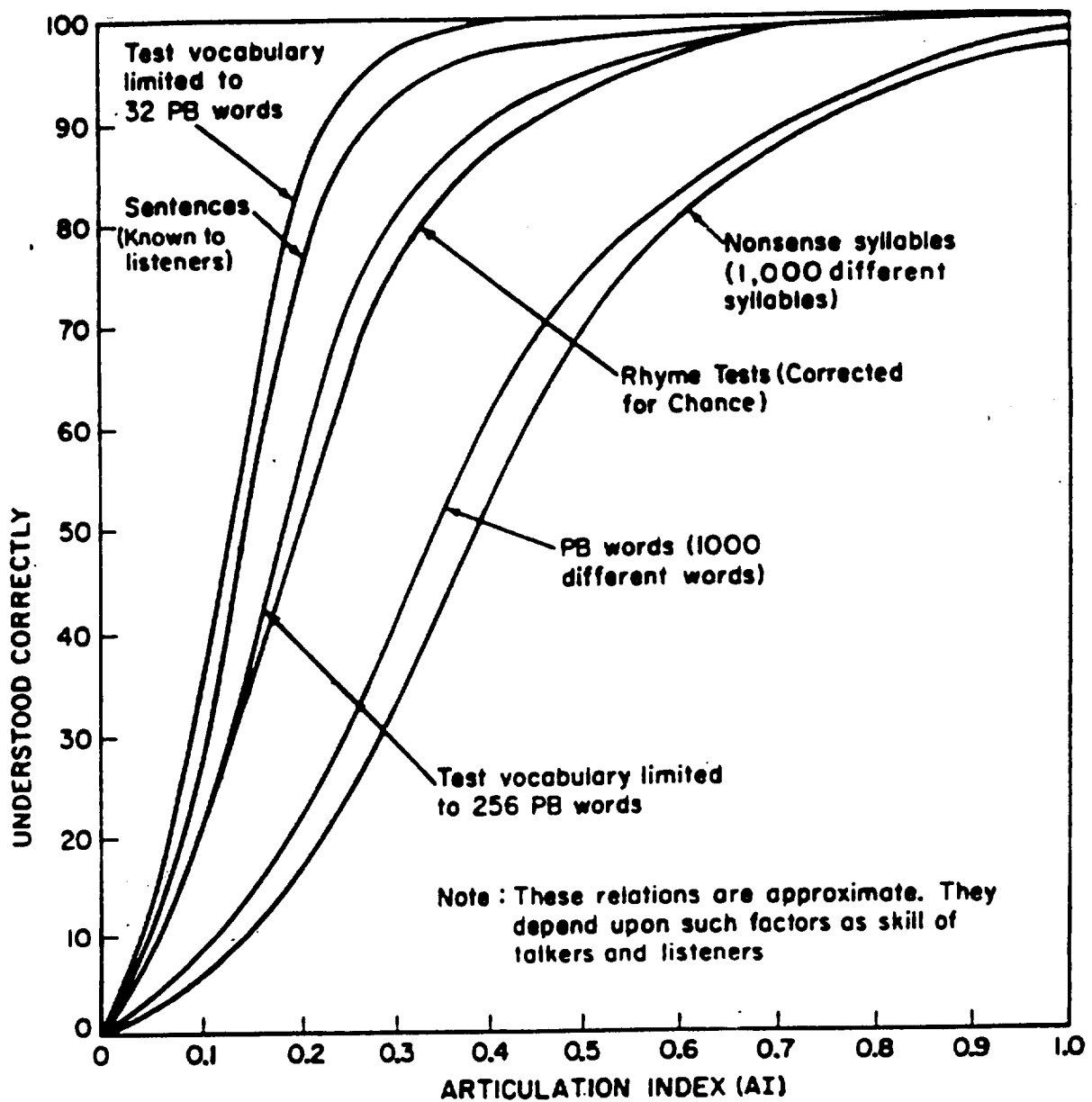

FIGURE A-1. Relationship between the Articulation Index (AI) and the intelligibility of various types of speech-text materials. (Kryter, 1966)

MIL-STD-1474D

briefings, meetings, etc., while airborne. A final consideration is communications via earphones or loudspeaker, e.g., the loud speaker system used to alert or instruct passengers.

SILs have been used as overall hearing damage or communication effectiveness criteria. This is particularly true where existing commercial aircraft are modified for military use. The SIL gives some spectral information as opposed to single number measures such as A-weighting. Jet aircraft noise is usually wide band in nature and the SIL can sometimes serve as a rough indicator of the overall noise levels. As such it may be of value during early design phases as a rough indicator of hearing damage risk and a good indicator of speech communications interference.

In no case, however, should the SIL criteria be substituted for the measurement requirements of 4.2.1.

REQUIREMENT GUIDANCE

This requirement should be invoked in cases where face-to-face, unaided speech communication will occur within the aircraft. This requirement must be tailored to reflect the specific mission needs of the aircraft for which it is invoked. The following instructions are designed to aid the human factors engineer (HFE) and tailoring and determining the applicability of this requirement. (See ANSI S3.14 for additional information.)

Mission area and phase. The SIL required should be limited only to those mission areas and phases in which face-to-face communications are highly critical or desirable. For example, if C₃ operations, which require face-to-face communications do not begin until the aircraft has attained cruise altitude and speed, the SIL requirements should be made specific to those conditions. In such a case the requirement would be filled in to read:

Speech interference levels (SIL) are required for flight member/mission areas as follow:

- a. Mission area SIL not to exceed _____ dBA at cruise altitude and speed with all auxiliary equipment operational.
- b. Flight deck between pilot and copilot SIL not to exceed _____ dBA during all mission phases.

Specify as many areas or crew positions as necessary.

Criteria. The SILs specified for each area should be based on the anticipated communications distance, communicating voice (based in part on frequency and duration of communication), and criticality of communications. Figure A-2 and tables A-II and A-III provide guidance. If face-to-face communications are to be frequent, lengthy or critical, the communicating voice should be expected to be "normal voice" (Figure A-2). Sustained speech at high levels is fatiguing. Normal voice is the usual speaking level; a 6 dB increase above the speaking levels is "raised voice"; a further increase of 6 dB is "very loud voice" and above that is "shouted noise voice." Another important voice level is "expected voice." It represents the increase of voice level adopted by a speaker located in a noisy field. The expected voice level increases from normal to very loud as the noise level increases from 55 dBA (51 dB SIL) to 95 dBA (91 dB SIL). The communicating voice level is the level a speaker can produce when forced to communicate (positive, instantaneous feedback that shows success or failure). Note that Figure A-2 has a dual scale showing SIL and dBA, and that this scale shows $\text{dBA} = \text{SIL} + 7 \text{ dB}$. This relationship is only an approximation. The consistency for evaluating interference with speech for a variety of noises is better for SIL than for dBA.

MIL-STD-1474D

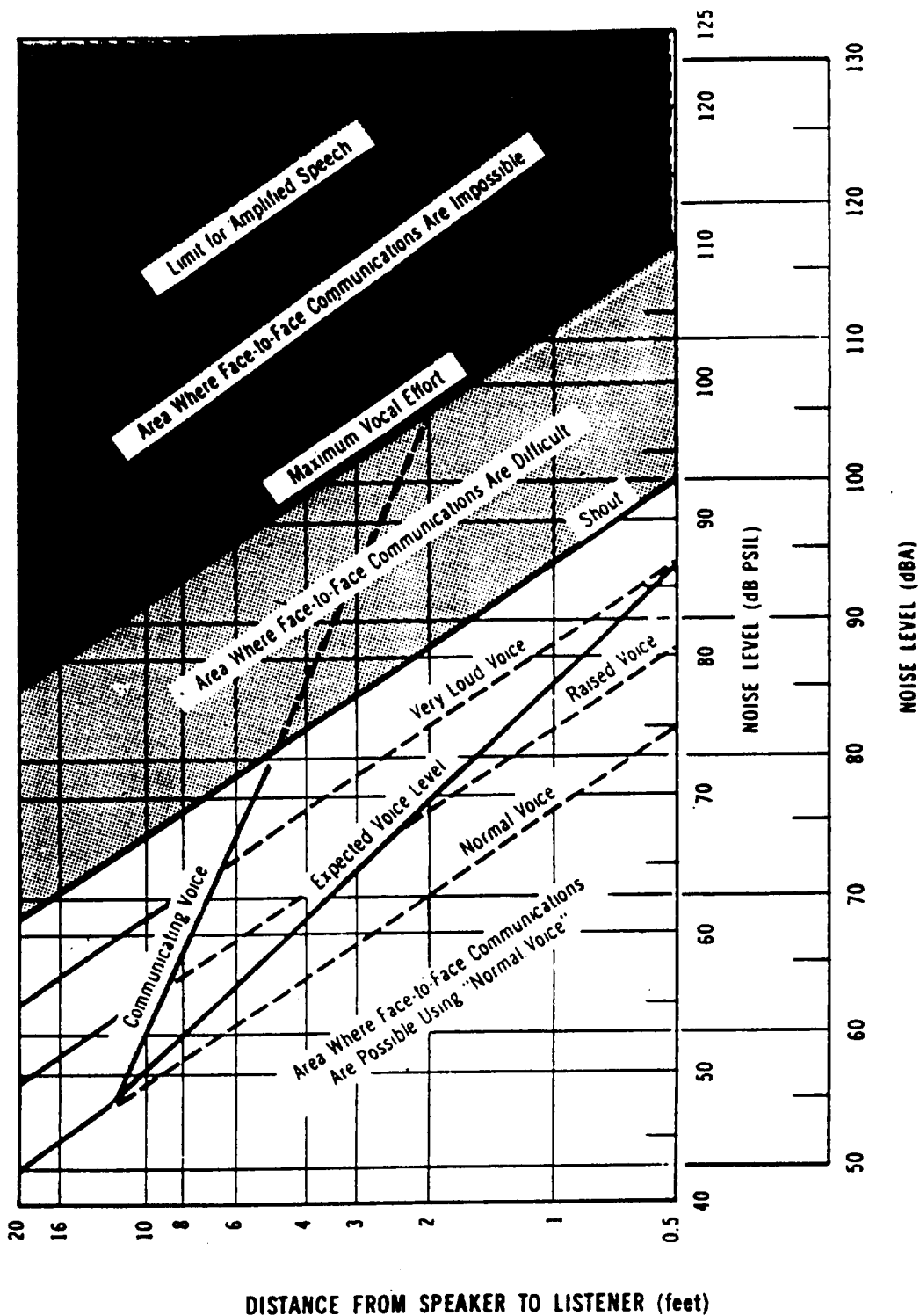

FIGURE A-2. Effectiveness of voice communication

NOTE: The effects of varying noise-exposure levels on satisfactory face-to-face speech communications are expressed here in terms of voice level and distance between maker and listener.

MIL-STD-1474D

TABLE A-II. Speech-interference levels that barely permit reliable conversation

Distance between talker and listener (ft)	Speech-interference levels (dB) ¹			
	Normal ²	Raised ²	Very Loud ²	Shouting ²
0.5	71	77	83	89
1.0	65	71	77	83
2.0	59	65	71	77
3.0	55	61	67	73
4.0	53	59	65	71
5.0	51	57	63	69
6.0	49	55	62	67
12.0	43	49	55	61

Beranek (1949).

¹ Correctly hearing 75% of PB words.

² Voice level.

TABLE A-III. Speech interference level criteria

Speech interference level (dB)	Person-to-person communication
30-40	Communication in normal voice satisfactory 1.8 to 9.1 m. Telephone use satisfactory.
40-50	Communication satisfactory in normal voice 0.9 to 1.8 m. and raised voice 1.8 to 3.7 m. Telephone use satisfactory to slightly difficult
50-60	Communication satisfactory in normal voice, 0.3 to 0.6 m. and raised voice, 0.9 to 1.8 m. Telephone use slightly difficult.
60-70	Communication with raised voice satisfactory, 0.3 to 0.6 m; slightly difficult, 0.9 to 1.0 m. Telephone use difficult. Earplugs and/or earmuffs can be worn with no adverse effects on communication.
70-80	Communication slightly difficult with raised voice, 0.3 to 0.6 m; slightly difficult with shouting 0.9 to 1.8 m. Telephone use very difficult. Earplugs and/or earmuffs can be worn with no adverse effects on communication.
80-85	Communication slightly difficult with shouting, 0.3 to 0.6 m. Telephone use unsatisfactory. Earplugs and/or earmuffs can be worn with no adverse effects on communication.

MIL-STD-1474D

TABLE A-III. Speech interference level criteria - Continued

Overall speech level (dB) minus SIL (dB) ¹	Person-to-person communication
+10 dB or greater	Communication satisfactory over range of SIL 30 to maximum SIL permitted by exposure time. ²
+ 5 dB	Communication slightly difficult. About 90% of sentence are correctly heard over range of SIL 30 to maximum SIL permitted by exposure time. ²
0 dB to -10 dB	Special vocabularies (i.e., radio-telephone voice procedures) required. Communication difficult to completely unsatisfactory over range of SIL 30 to maximum SIL permitted by exposure time. ²
<p>¹ Overall long time rms sound pressure level of speech and the SIL for the noise must be measured at or estimated for a position in the ear canal of the listener. Long-time rms value of speech can be approximated by subtracting 4 dB from the peak VU meter readings on monosyllabic words.</p> <p>² Earplugs and/or muffs worn in noise having SILs above 60 dB will not adversely affect communication for persons with normal hearing and will extend maximum permissible SIL in accordance with protection provided.</p>	

5.4.3 Verification of speech interference level. Verification shall be by analysis of modeling and measurement data generated by 5.2.1.

VERIFICATION RATIONALE (5.4.3)

Speech interference level is an analytical technique based on engineering projections and measured data. Therefore, verification must be by analysis.

VERIFICATION GUIDANCE

Ultimately, verification will be performed on the measured data required by 4.2.1.

4.5 Data Collection

4.5.1 Sound level measurements. noise measurements shall be made on the first completely configured aircraft. When modifications impact flight member noise levels, additional acoustical measurements shall be accomplished.

MIL-STD-1474D

REQUIREMENT RATIONALE (4.5.1)

Noise level measurements must be made as soon as the first completely configured aircraft becomes available so that any noise-related problems can be identified and resolved in a timely manner. Additional measurements must be taken to ensure compliance when modifications which could impact noise levels are made.

REQUIREMENT GUIDANCE

Modifications, ECPs, etc., must be reviewed taking into consideration potential impacts on noise. If a question exists as to the potential impacts of a modification, consult the appropriate service laboratory.

5.5.1 Verification of sound level measurements. Verification shall be by inspection of contractor test plans, ECPs, and other documentation.

VERIFICATION RATIONALE (5.5.1)

On going inspection of documentation is necessary to assure that engineering changes which add to interior noise levels are monitored, and any necessary measurements taken.

VERIFICATION GUIDANCE

It is important to monitor changes which could cause an increase in interior noise levels. Such changes may seem to have little human factors impact, and as a result, may not be forwarded to the responsible HFE for review. The HFE should discuss this requirement with the program management so that he/she will be given the opportunity to review changes that might affect interior noise levels.

4.5.2 Flight conditions. Noise measurements shall be made with the aircraft at the flight modes identified in the mission profiles of 4.2.1. All auxiliary systems normally used for each designated flight mode shall be in operation during the measurement.

REQUIREMENT RATIONALE (4.5.2)

Noise measurements must be made in all of the operational flight conditions specified in 4.2.1. A second intent is to assure that any and all auxiliary systems which might add to interior noise are in operation when flight measurements are taken.

REQUIREMENT GUIDANCE

Invoke this requirement whenever noise measurements are required. The first sentence of this requirement is self explanatory. Auxiliary systems such as heating, air conditioning, gasper air (personal air vent), etc., should be in normal operating modes to simulate as closely as possible the operational noise environment. Intermittent noise sources such as warning tones need not be included in noise measurements.

5.5.2 Verification of flight conditions. Verification shall be by inspection of test plans and test reports.

VERIFICATION RATIONALE (5.5.2)

Inspection is a sufficient means of verification.

MIL-STD-1474D

VERIFICATION GUIDANCE

Inspect the test plans and test reports to verify that the requirement has been met. The best means for ensuring compliance is to talk to the engineers who will conduct the measurements. The earlier this is accomplished, the better.

4.5.3 Measurement locations. Noise measurement shall be made at the head levels of all flight members in all relevant mission areas. When possible, noise measurements shall be made with the flight member absent and at the normal ear position 80 cm above the seat at a standing height of 165 cm. During each measurement, the microphone should be oriented vertically with the diaphragm facing up and rotated in a 15 to 30 cm horizontal circle.

The microphone location and orientation shall be subject to acquisition activity approval. The following shall be included in the measurement report:

- a. The coordinates of each measurement station shall be stated numerical and illustrated on an inboard profile or plan view of the aircraft. Note if the station was occupied during measurement.
- b. Where a flight member has freedom of movement, a mission area maximum, minimum, and average noise levels in the area shall be reported.
- c. Where time variations in noise levels may be significant, e.g., beats in propeller, noise data shall be obtained for a period of time sufficient to define minimum and maximum levels.

REQUIREMENT RATIONALE (4.5.3)

The intent of this requirement is to provide a standard methodology for microphone locations during testing. Standard measurement techniques allow interaircraft comparisons and objective evaluation against noise criteria. In addition, microphones must be placed in locations that approximate operator working positions for criteria to be valid.

REQUIREMENT GUIDANCE

Invoke this requirement whenever sound measurements will be made.

5.5.3 Verification of measurement locations. Verification shall be by analysis of test plans and test reports.

VERIFICATION RATIONALE (5.5.3)

Analysis of test and system information is necessary to ensure compliance with this requirement.

VERIFICATION GUIDANCE

Analyze the test plans and reports to verify that the requirement has been met.

4.5.4 Measurement Information. All data shall be recorded using a(n) _____ recorder.

REQUIREMENT RATIONALE (4.5.4)

Analog tape recorders are necessary at this time to accurately record high frequency data;

MIL-STD-1474D

however, advances in digital recording equipment are being made and may be used with adequately supported rationale approved by the procuring activity.

REQUIREMENT GUIDANCE

All recording equipment should conform to ANSI S1.2. The blank should be filled with "analog tape" unless the contractor has provided adequately supported evidence that digital equipment will conform to the above ANSI standard; the decision to use digital equipment shall be subject to the approval of the procuring activity. The contractor may be required to transfer digitally recorded data to analog before subsequent government use.

5.5.4 Verification of data measurement information Verification shall be by inspection of test plans and test reports.

VERIFICATION RATIONALE (5.5.4)

Inspection of contract or test plans and methods is sufficient to verify that proper recording equipment is used.

VERIFICATION GUIDANCE

The contractor's test plan should state explicitly the recording equipment to be used.

4.5.5 Recording time. Each noise measurement shall be at least 30 seconds in duration.

REQUIREMENT RATIONALE (4.5.5)

Thirty seconds of data for each flight mode and occupant position is a minimum to provide adequate samples.

REQUIREMENT GUIDANCE

Invoke this requirement whenever measurements are taken. The requirement should not be tailored.

5.5.5 Verification of recording time. Verification shall be by analysis of test plans, test reports, and data tapes.

VERIFICATION RATIONALE (5.5.5)

Analysis is sufficient to verify this requirement.

VERIFICATION GUIDANCE

Verification may be accomplished by inspection of plans and data, which should specify the duration of each record.

4.5.6 Simulation/communication. A 60-second in-flight recording of the electrical noise in the communication system shall be made at a single key interconnection jack (e.g., pilot or co-pilot). The recording shall be made across an 8-ohm impedance connected to the headset lines, with the interphone volume control(s) set at maximum. Communication silence (no microphone keyed) shall be maintained during the period of recording. Actual recording shall be preceded and ended with a calibration tone (1000 Hz sinusoidal signal 200 milliwatts, 8-ohm).

MIL-STD-1474D

REQUIREMENT RATIONALE (4.5.6)

A recording of electrical noise in the recording system is needed for MRT or AI analysis. Such recordings may be useful for other analyses as well.

REQUIREMENT GUIDANCE

Invoke this requirement whenever measurements are made, even if the MRT or AI are not planned to be used. The cost of taking this extra measurement is virtually nil and the data are useful for communications intelligibility analysis. This requirement should require no tailoring.

5.5.6 Verification of simulation/communication. Verification shall be by analysis of test plans and test reports.

VERIFICATION RATIONALE (5.5.6)

Analysis of contractor plans and data is sufficient to verify this requirement

VERIFICATION GUIDANCE

Check the test plans to ensure that the calibration tone will be used. The flight mode in which the measurement will be taken should be identified, as well as which auxiliary systems will be in operation.

4.6 Instrumentation

REQUIREMENT RATIONALE (4.6)

Standard noise measurement equipment and methods are required to ensure objective evaluations and to allow interaircraft comparisons.

REQUIREMENT GUIDANCE

Invoke this requirement whenever measurements are made. The requirement should normally require no tailoring. If the contractor requests a deviation to any of the required ANSI standards, the HFE should consult AFWAL/FBG to determine the significance of the deviation.

5.6 Verification of instrumentation. Verification shall be by analysis and inspection of test plans and test reports.

VERIFICATION RATIONALE (5.6)

Analysis and inspection of the sources listed above should suffice. However, if the contractor lacks the necessary calibration or measurement equipment, government tests may be necessary to endure compliance.

VERIFICATION GUIDANCE

Equipment used for SPL measurements is designed and manufactured to applicable industry and government standards. In such cases, verification consists of inspecting equipment specifications. Calibration is usually performed by specialty subcontractors; inspection of calibration records should suffice. The shielding and electrical isolation requirements may require analysis; consult the SPO electrical engineers or ASC/ENA for assistance.

MIL-STD-1474D

APPENDIX B.

HEARING PROTECTOR NOISE ATTENUATION

B.1 SCOPE

B.1.1 Scope. This appendix provides tabulations of noise attenuation capabilities for various types of hearing protectors: muffs, inserts, helmets, communication headsets, and combination of muffs and ear plugs.

B.1.2 Use. The tabulations are provided primarily to support information needs of Requirement 6 required to determine time weighted average sound level, dependent in part on usage of hearing protectors.

B.2 APPLICABLE DOCUMENTS

B.2.1 General. The documents listed below are not necessarily all the documents referenced herein but are the ones that are needed in order to fully understand the information provided by this Appendix.

B.2.2 Government documents.

B.2.2.1 Handbook. The following handbook forms a part of this document to the extent specified herein. Unless otherwise specified, the issues of that handbook is that listed in the issue of the Department of Defense Index of Specifications and Standards (DoDISS) and supplement thereto, cited in the solicitation (see 6.2).

DEPARTMENT OF DEFENSE

MIL-HDBK-1908 - Definitions of Human Factors Terms

(Unless otherwise indicated, copies of federal and military specifications, standards, and handbooks are available from the Standardization Documents Order desk, 700 Robbins Avenue, Bldg 4D, Philadelphia, PA 19111-5094.)

B.2.2.2 Other Government documents, drawings, and publications. Not applicable.

(Copies of specifications, standards, and other publications required by contractors in connection with specific acquisition functions should be obtained from the contracting activity or as directed by the contracting officer.)

B.2.3 Non-government publications. The following document(s) form a part of this document to the extent specified herein. Unless otherwise specified, the issues of the documents which are DoD adopted are those listed in the latest issue of the DoDISS, and supplements thereto. Unless otherwise specified, the issues of these documents not listed in the DoDISS are the issues of the documents cited in the solicitation (see 6.2).

AMERICAN NATIONAL STANDARDS INSTITUTE (ANSI)

ANSI S1.1 - Acoustical Terminology
 ANSI S3.19 - Measurement of Real-Ear Protection of Hearing Protectors and Physical Attenuation of Earmuffs (DoD Adopted)
 ANSI S12.6 - Measurement of the Real-Ear Attenuation of Hearing Protectors, Method for (DoD Adopted)

MIL-STD-1474D

- ANSI S12.42 - Microphone-In-Real-Ear and Acoustic Test Fixture Methods for the Measurement of Insertion Loss of Circumaural Hearing Protection Devices
- ANSI Z24.22 - Standard Method for the Measurement of the Real-Ear Attenuation of Ear Protectors at Threshold

(Requests for copies should be addressed to the American National Standards Institute, Inc., 1430 Broadway, New York, NY 10018.)

B.3 DEFINITIONS

Terms are defined in accordance with MIL-HDBK-1908. Terms not appearing in MIL-HDBK-1908 are defined in accordance with ANSI S1.1.

B.4 NOISE REDUCTION PROVIDED BY PERSONAL HEARING PROTECTOR DEVICES

Noise reduction provided by personal hearing protector devices are contained in tables B-1 and B-2 herein. Attenuation characteristics of devices not listed are those established by the procedures in ANSI S12.6 or ANSI 12.42, as applicable.

MIL-STD-1474D

Table B-I. Hearing protector noise attenuation (dBA) for noise source C-A values

	Noise Source Measured C-A Values				
	-2 thru 0	1 thru 3	4 thru 7	8 thru 12	13 and up
QPL Muffs (configured over the head)					
American Optical 1720SD ¹	27	24	30	16	11
Bilsom UF1S	25	23	19	15	10
David Clark E-310 ¹	29	26	22	18	12
MSA Mark IV (#95635)	23	20	17	13	7
Wilson 365 (HS)	31	28	26	22	17
Inserts					
Comfit (Triple flange)	18	18	18	17	17
E.A.R.	22	21	20	18	16
Flents	23	22	20	18	16
PROPP-O-LAST (US mil Config)	21	19	18	15	13
V-51R	19	18	17	15	12
Helmets					
HGU-26/P w/pillow block earcups ¹	5	3	1	0	0
HGU-26/P w/MX8376/AR earcups ¹	10	7	4	1	0
HGU-39/P	22	20	18	15	10
Communications					
H-133	25	24	23	22	20
H-133 (modified with custom molded insert)	31	29	27	24	20
H-157	17	15	13	10	6
Combination QPL Muff & Ear Plugs (V51 or E.A.R.)					
	34	34	32	31	28

¹These devices evaluated according to ANSI S3.19. All other devices evaluated per ANSI Z24.22

MIL-STD-1474D

Table B-II. Hearing protector noise Attenuation (dB) by octave bands

	Octave Band Center Frequencies (Hz)						
	125	250	500	1K	2K	4K	8K
QPL Muffs (configured over the head)¹							
American Optical 1720SD ²	6	13	25	35	30	31	27
Bilsom UF1S	8	11	20	32	32	34	21
David Clark E-310 ²	8	15	28	33	32	32	31
MSA Mark IV (#95635)	10	18	29	32	37	44	31
Wilson 365 (HS)	13	20	27	36	34	36	25
Inserts							
Comfit (Triple flange)	18	17	16	17	22	16	23
E-A-R	22	15	18	18	29	33	29
Flents	15	15	18	21	29	29	24
PROPP-O-LAST (US mil Config)	12	12	15	19	22	27	26
V-51R	13	12	15	18	21	19	15
Helmets							
HGU-26/P w/pillow block earpad ²	0	0	0	3	5	12	24
HGU-26/P w/MX8376/AR earcups ²	0	0	4	14	20	23	16
HGU-39/P	9	11	16	23	24	40	20
Communications							
H-133	14	23	36	22	24	28	25
H-157 (Astrocom)	1	8	12	21	20	25	10
H-133 (modified with custom molded insert)	17	22	25	30	35	42	29
Combination QPL Muff & Ear Plugs (V51 or E-A-R)							
	25	30	33	33	35	43	36

¹ Qualified Product List (QPL) items are listed on the QPL for ear muffs. QPLs for other HPDs are not yet available.

² These devices evaluated according to ANSI S3.19. All other devices evaluated per ANSI Z24.22

MIL-STD-1474D

CONCLUDING MATERIAL

Custodians:

Army - MI
Navy - AS
Air Force - 11

Preparing activity:

Army-MI
(Project HFAC-0075)

Review activities:

Army - AM, AT, MD, ME, TD
Navy - OS, TD, YD

Industry associations:

AIA
ASA
EIA
HFES
SAE

Civil Agency Coordinating Activities:

DOT - FAA
EPA
NASA - MSF
NIST
DOL (OSHA)

STANDARDIZATION DOCUMENT IMPROVEMENT PROPOSAL

INSTRUCTIONS

1. The preparing activity must complete blocks 1, 2, 3, and 8. In block 1, both the document number and revision letter should be given.
2. The submitter of this form must complete blocks 4, 5, 6, and 7.
3. The preparing activity must provide a reply within 30 days from receipt of the form.

NOTE: This form may not be used to request copies of documents, nor to request waivers, or clarification of requirements on current contracts. Comments submitted on this form do not constitute or imply authorization to waive any portion of the referenced document(s) or to amend contractual requirements.

I RECOMMEND A CHANGE:

1. DOCUMENT NUMBER
MIL-STD-1474D

2. DOCUMENT DATE (YYMMDD)
970212

3. DOCUMENT TITLE

NOISE LIMITS

4. NATURE OF CHANGE *(Identify paragraph number and include proposed rewrite, if possible. Attach extra sheets as needed.)*

5. REASON FOR RECOMMENDATION

6. SUBMITTER

a. NAME *(Last, First, Middle Initial)*

b. ORGANIZATION

c. ADDRESS *(Include Zip Code)*

d. TELEPHONE *(Include Area Code)*
(1) Commercial
(2) AUTOVON
(if applicable)

7. DATE SUBMITTED
(YYMMDD)

8. PREPARING ACTIVITY

a. NAME

U.S ARMY MISSILE COMMAND

b. TELEPHONE *Include Area Code)*
(1) Commercial (2) AUTOVON

c. ADDRESS *(Include Zip Code)*

Commander, US Army Missile Command
ATTN: AMSMI-RD-SE-TD-ST
REDSTONE ARSENAL, AL 35898-5270

IF YOU DO NOT RECEIVE A REPLY WITHIN 45 DAYS, CONTACT:
DEFENSE QUALITY AND STANDARDIZATION OFFICE
5203 Leesburg Pike, Suite 1403, Falls Church, VA 22401-3466
Telephone (703) 756-2340 AUTOVON 289-2340