

MILITARY STANDARD
UNIT LOAD
FOR UNDERWAY REPLENISHMENT
AMRAAM, AIM-120A IN S/S/C, CNU-415A/E
OR
AMRAAM JAIM-120A CAPTIVE
AIR TRAINING MISSILE (CATM)
IN S/S/C CNU-555/E

MIL-STD-1323-360A
(NAVY)
26 OCT 1993
 SUPERSEDING
 MIL-STD-1323-360
 8 MAY 1991

UNIT LOAD DATA

NUMBER OF MISSILES/CONTAINER ----- 4
 NUMBER OF CONTAINERS/UNIT LOAD ----- 2
 GROSS WEIGHT OF ONE CONTAINER ----- 2,075 LBS.
 WEIGHT OF STEEL STRAPPING ----- 6 LBS.
 GROSS WEIGHT OF UNIT LOAD ----- 4,156 LBS. Δ
 CUBE ----- 126.8 CU. FT.
 Δ DO NOT USE FOR SHIPPING WEIGHT
 FOR HAZARD CLASSIFICATION SEE SW020-AS-SAF-010/020/030
 DATA SHOWN IS FOR BOTH CONTAINERS.

CNU-415A/E CONTAINER DWG # 30003-3145AS100
 CNU-555/E CONTAINER DWG # 30003-3390AS100

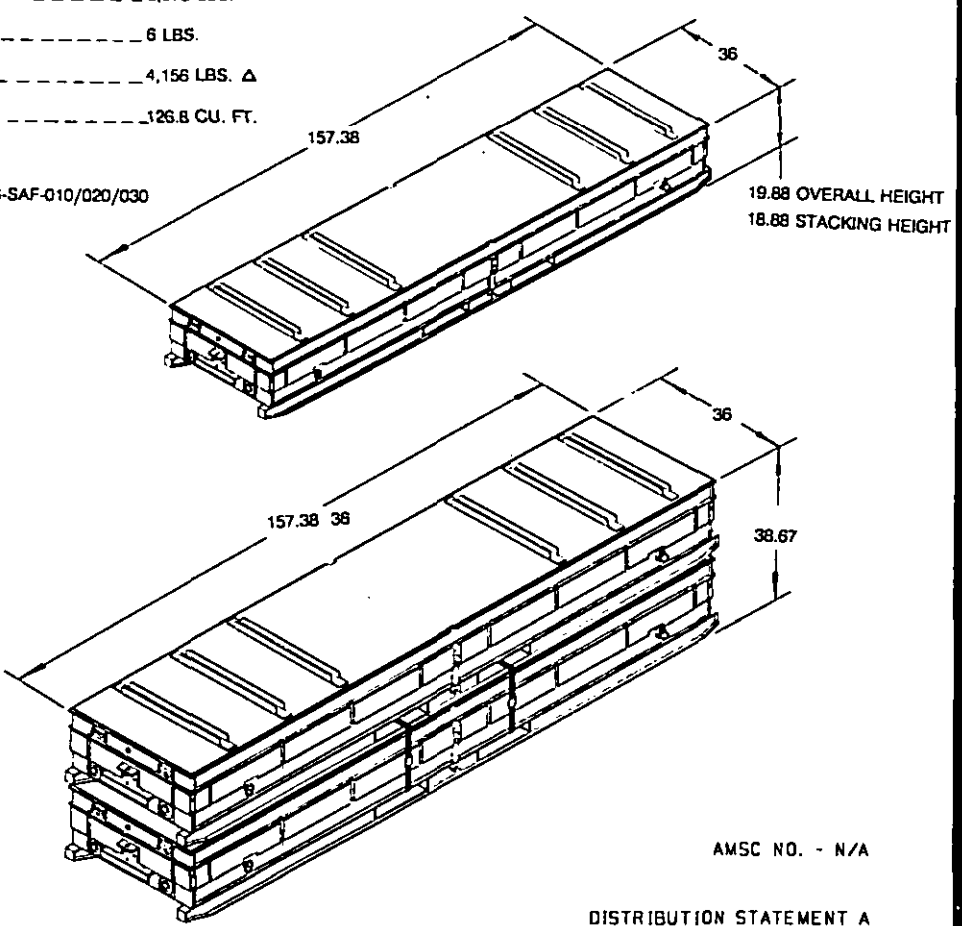

AMSC NO. - N/A

DISTRIBUTION STATEMENT A
 APPROVED FOR PUBLIC RELEASE :
 DISTRIBUTION IS UNLIMITED.

NOTES:
 1. UNLESS OTHERWISE SPECIFIED DIMENSIONS ARE IN INCHES.
 2. FOR CROSS REFERENCE TO ASSOCIATED TRUCKLOADING, CONTAINERLOADING AND CARLOADING MILITARY STANDARDS, REFER TO INDEX TO STANDARDS, MIL-HDBK-236 (NAVY).

| | | | | |
|-----|---|--------|----------|--------|
| A | ADDED CNU-555/E S/S/C AND UP DATED DOCUMENT | 5/1/91 | ep | ae |
| REV | REVISION DESCRIPTION | DATE | TDA | SYSCOM |
| LTR | | | APPROVAL | |

FSC 8140

THIS UNIT LOAD IS AUTHORIZED AND RELEASED FOR SHIPPING, HANDLING, STORAGE AND TRANSFER-AT-SEA. IT MAY ALSO BE USED FOR DOMESTIC SHIPMENT IN COMPLIANCE WITH DOT REGULATIONS.

REQUIREMENTS FOR CONSTRUCTION OF THIS UNIT LOAD SHALL CONSIST OF THIS DOCUMENT AND THE LATEST ISSUE OF MIL-STD-1323 (NAVY).

C. Ronald 5/8/91
 SIGNATURE TDA, WPNSTA EARLE DATE
William Schaefer 5/9/91
 SIGNATURE AIRSYS COM BY DIRECTION DATE

ORIGINATOR *WPNSTA EARLE* 5/8/91
 DATE
 WPNSTA EARLE, NEW JERSEY PAGE 1 OF 2

MIL-STD-1323-360A (NAVY)

UNITIZING PROCEDURE

1. PLACE ONE CONTAINER ON TOP OF ANOTHER. MAKE SURE TO ENGAGE THE STACKING FEATURES.
2. THREAD STRAPPING, ITEM 1, THROUGH THE FORK POCKETS OF LOWER CONTAINER AND UP THROUGH THE FORK POCKETS OF THE UPPER CONTAINER. TENSION STRAPPING, ITEM 1, AND DOUBLE NOTCH SEAL, ITEM 2.

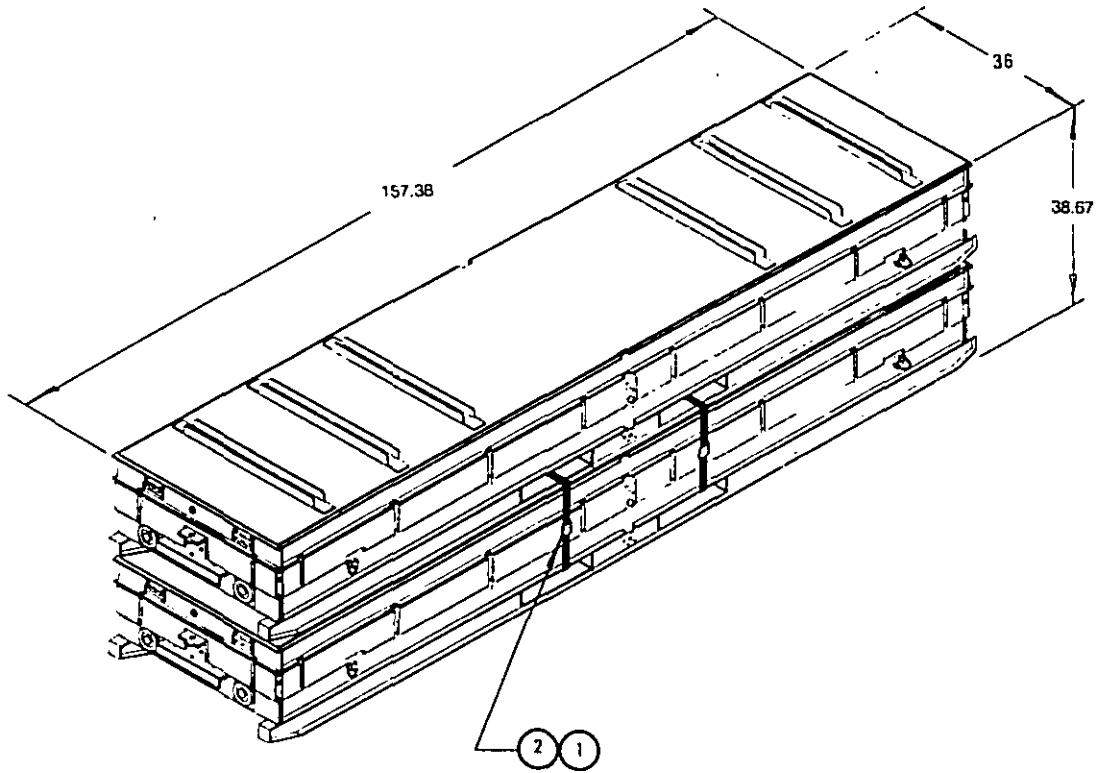

NOTE: UNLESS OTHERWISE SPECIFIED ALL MATERIALS SHALL BE IAW MIL-STD 1323 (NAVY).

DEUNITIZING PROCEDURE

1. CUT AND REMOVE STRAPPING.
2. REMOVE TOP CONTAINER.

| 2 | 2 | SEAL | STEEL | FOR 1 1/4 STRAPPING |
|-----|------|-------------|-----------|------------------------|
| 2 | 1 | STRAPPING | STEEL | 1 1/4 X .035 X 10 FT 6 |
| REQ | ITEM | DESCRIPTION | MAT'L/DWG | DIMENSIONS |

LIST OF MATERIALS

PREPARING ACTIVITY:
NAVY-OS
(PROJECT NO. 8140-0058)