

MILITARY STANDARD

MIL-STD-1322-898

UNIT LOAD

(NAVY)

2 JUNE 1993

FOR DOMESTIC AND OVERSEAS SHIPMENT

WARHEAD, GUIDED MISSILE HIGH EXPLOSIVE

WDU-33/B IN SHIPPING AND STORAGE

UNIT LOAD DATA

CONTAINER CNU-545/E

NUMBER OF WARHEADS / CONTAINER _ _ _ _ _ 1
 NUMBER OF CONTAINERS/ PALLET _ _ _ _ _ 8
 GROSS WEIGHT OF ONE CONTAINER _ _ _ _ _ 133 LBS.
 WEIGHT OF STEEL PALLET _ _ _ _ _ 94 LBS.
 WEIGHT OF ADAPTER (TOP & BOTTOM) _ _ _ _ _ 156 LBS.
 WEIGHT OF ALL STEEL STRAPPING _ _ _ _ _ 12 LBS.
 GROSS WEIGHT OF 8 CONTAINERS _ _ _ _ _ 1,064 LBS.
 GROSS WEIGHT OF UNIT LOAD _ _ _ _ _ 1,314 LBS. Δ
 CUBE _ _ _ _ _ 71.35 CU. FT.

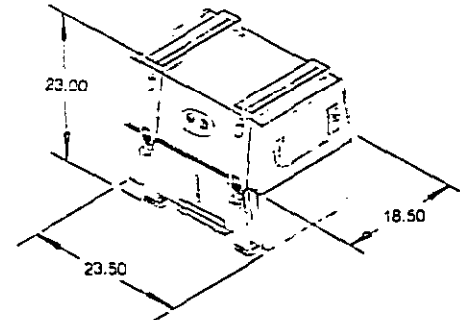

Δ DC NOT USE FOR SHIPPING WEIGHT
 DO NOT STACK MORE THAN UNIT LOADS
 HIGH IN STORAGE
 FOR HAZARD CLASSIFICATION SEE SWO20-AC-SAF-010
 FOR UNIT LOAD QUALIFICATION
 SEE NWSE TEST REPORT # 83056

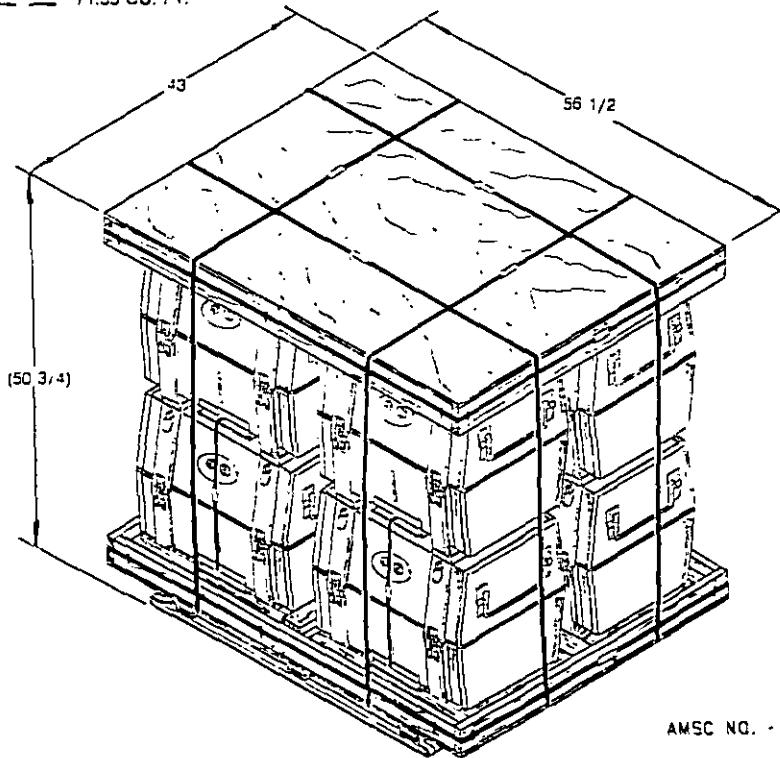

AMSC NO. - N/A

DISTRIBUTION STATEMENT A
 APPROVED FOR PUBLIC RELEASE:
 DISTRIBUTION IS UNLIMITED.

NOTES:

- UNLESS OTHERWISE SPECIFIED DIMENSIONS ARE IN INCHES.
- FOR CROSS REFERENCE TO ASSOCIATED TRUCKLOADING, CONTAINERLOADING AND CARLOADING MILITARY STANDARDS, REFER TO INDEX TO STANDARDS, MIL-HOBK-236 (NAVY).

FSC 8140

REV LTR	REVISION DESCRIPTION	DATE	TDA	SYSCOM
			APPROVAL	

THIS UNIT LOAD IS AUTHORIZED AND RELEASED FOR DEPOT HANDLING AND STORAGE AND FOR SHIPMENT BY COMMON CARRIER.

REQUIREMENTS FOR CONSTRUCTION OF THIS UNIT LOAD SHALL CONSIST OF THIS DOCUMENT AND THE LATEST ISSUE OF MIL-STD-1322 (NAVY).

SIGNATURE TDA, WPNSTA EARLE DATE

ORIGINATOR _____ DATE

SIGNATURE NAVAIRSYSCOM BY DIRECTION DATE

WPNSTA EARLE, NEW JERSEY PAGE 1 OF 5

PALLETIZING PROCEDURE

1. POSITION LONGITUDINAL STRAPPING, ITEM 2, BETWEEN THE 6th & 7th WIRES OF PALLET, ITEM 1, AS SHOWN IN DETAIL A.
2. POSITION ONE ADAPTER ASSY, (DETAIL B) ON PALLET, ITEM 1, WITH EQUAL OVERHANG ON BOTH SIDES AND ENDS.
3. CAREFULLY POSITION (4) UNITIZED CONTAINERS (DETAIL E) IN PARTITION SPACE OF ADAPTER WITH BREATHER VALVE AND HUMIDITY INDICATOR FACING OUTWARD AS SHOWN IN DETAILS C & D.
- * 4. POSITION ONE ADAPTER ASSY, (DETAIL B) OVER THE UNITIZED CONTAINERS AND ALIGN EDGES WITH EDGES OF BOTTOM ADAPTER.
5. POSITION LATERAL STRAPPING, ITEM 3, UNDER THE PALLET DECK AND OVER THE LOAD WITHIN DIMS SHOWN. TENSION AND DOUBLE NOTCH SEALS ITEM 5.
6. BRING LONGITUDINAL STRAPPING OVER THE LOAD. TENSION AND DOUBLE NOTCH SEAL ITEM 5.
7. SECURE STRAPPING TO ADAPTER WITH STAPLES ITEM 6, 8PL AS SHOWN.

MARKING: IN ADDITION TO ANY SPECIAL MARKING REQUIRED BY CONTRACTOR OR ORDER, THE UNIT LOAD SHALL BE MARKED IAW MIL-STD-129.

* NOTE:

WHEN POSITIONING TOP ADAPTER ASSY OVER CONTAINERS IT MAY REQUIRE A SLIGHT SHIFTING OF THE CONTAINERS IN THEIR CELLS TO ALLOW FOR A FLUSH FIT.

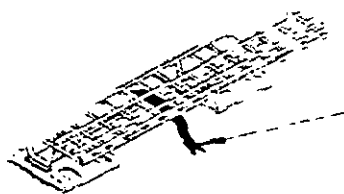
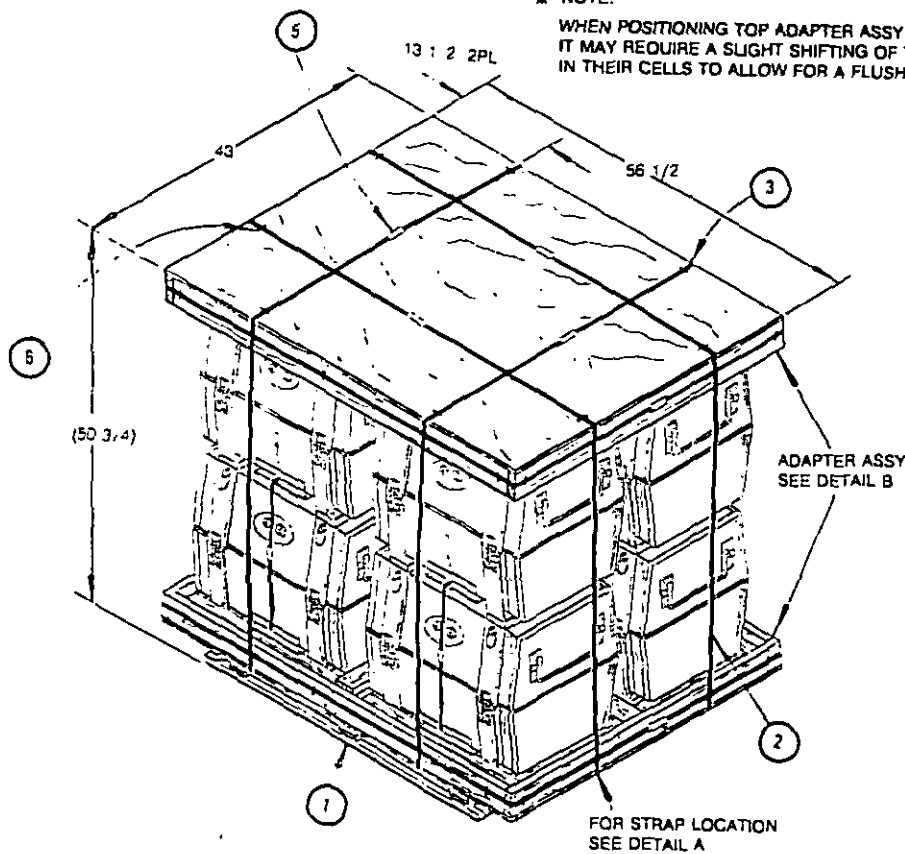

DETAIL A

SUGGESTED NAILING PROCEDURE

MIL-STD-1322-898 (NAVY)

- a. NAIL ITEM 7, TO ITEM 8, W/2-16d NAILS/JOINT 4PL.
- b. NAIL BASE, (PLYWOOD SHEET), TO ITEMS 7, 8, AND 9 W/6d NAILS EVERY 6-7 INCHES.
- c. JOIN TOGETHER 3PCS OF ITEM 9 W/7-10d NAILS/JOINT STAGGERED.
- d. PLACE THE (3) JOINED PCS OF ITEM 9 IN BOTTOM OF BASE WITHIN DIMENSION SHOWN. SECURE IN PLACE BY NAILING THROUGH ITEM 8 W/4-10d NAILS 2PL.
- e. TOE NAIL ITEM 10, TO ITEM 9, W/2-10d NAILS/JOINT WITHIN DIMS SHOWN 2PL.
- f. NAIL ITEM 7, TO ITEM 10 W/2-16d NAILS/JOINT 2PL.
- g. TOE NAIL ITEM 14, (SPACER LONG) TO ITEM 9, W/2-10d NAILS 4PL.
- h. NAIL ITEM 7, TO ITEM 14, W/2-16d NAILS/JOINT 4PL.
- j. TOE NAIL ITEM 13, (SPACER SHORT) TO ITEMS 14 & 10 W/2-10d NAILS/JOINT 4PL.
- k. NAIL ITEM 8, TO ITEM 14, W/2-16d NAILS/JOINT 4PL.

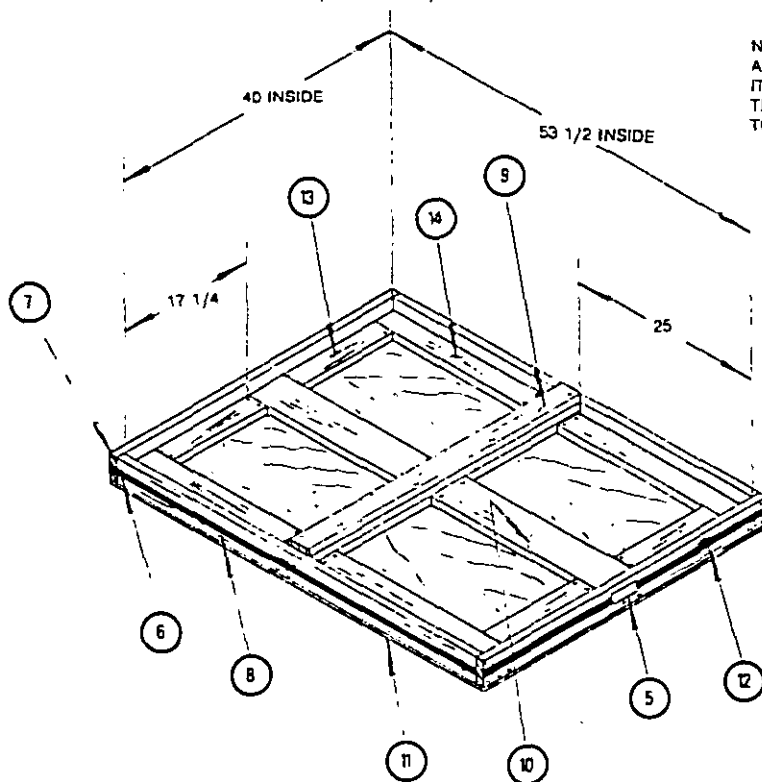

NOTE:
AFTER ADAPTER IS FABRICATED, POSITION STEEL STRAP, ITEM 12, AROUND OUTSIDE SURFACE OF ADAPTER AS SHOWN. TENSION AND DOUBLE NOTCH SEAL, ITEM 5. SECURE STRAPPING TO ADAPTER WITH STAPLES ITEM 6 10PL AS SHOWN.

DETAIL E

ADAPTER ASSY (BOTTOM OR TOP)
2 REQ'D

ALL MATERIALS SHALL BE IAW MIL-STD-1322 (NAVY)

* NOTE: ITEMS 13 & 14 SPACERS TO FIT SNUG, 1/8 MAX CLARENCE PERMISSIBLE. STOCK (2 X 3) CAN BE CUT FROM LARGER STOCK. CUT SIZE 2 X 2 1/2.

4	14	SPACER (LONG) (DETAIL B)	WOOD	2 X 3 X 24 7/8 * SEE NOTE
4	13	SPACER (SHORT)	WOOD	2 X 3 X 17 1/4 * SEE NOTE
1	12	STRAP (DETAIL B)	STEEL	.035 X 3/4 X 16 FT
1	11	BASE	PLYWOOD	1/2 X 56 1/2 X 43
2	10	CLEAT, CENTER	WOOD	2 X 6 X 25
3	9	CLEAT, INNER	WOOD	2 X 4 X 43
2	8	CLEAT, SIDE	WOOD	2 X 4 X 56 1/2
2	7	CLEAT, END (DETAIL B)	WOOD	2 X 4 X 43
AR	6	STAPLES	STEEL	3/4
1		SEAL- (ADAPTER ASSY)	STEEL	FOR 3/4 STRAPPING
1	5	SEAL- (CNTNR UNITIZING)	STEEL	FOR 3/4 STRAPPING
4		SEAL- (UNIT LOAD)	STEEL	FOR 3/4 STRAPPING
1	4	STRAP, CNTNR UNITIZING	STEEL	.035 X 3/4 X 7 FT 6
2	3	STRAP, LATERAL	STEEL	.035 X 3/4 X 17 FT 6
2	2	STRAP, LONGITUDINAL	STEEL	.035 X 3/4 X 16 FT 6
1	1	PALLE ^T MK 3 MOD 0	STEEL-564200	40 X 46 X 4 3/4
REQ	ITEM	DESCRIPTION	MAT'L/DWG	DIMENSIONS

LIST OF MATERIALS

PAGE 3

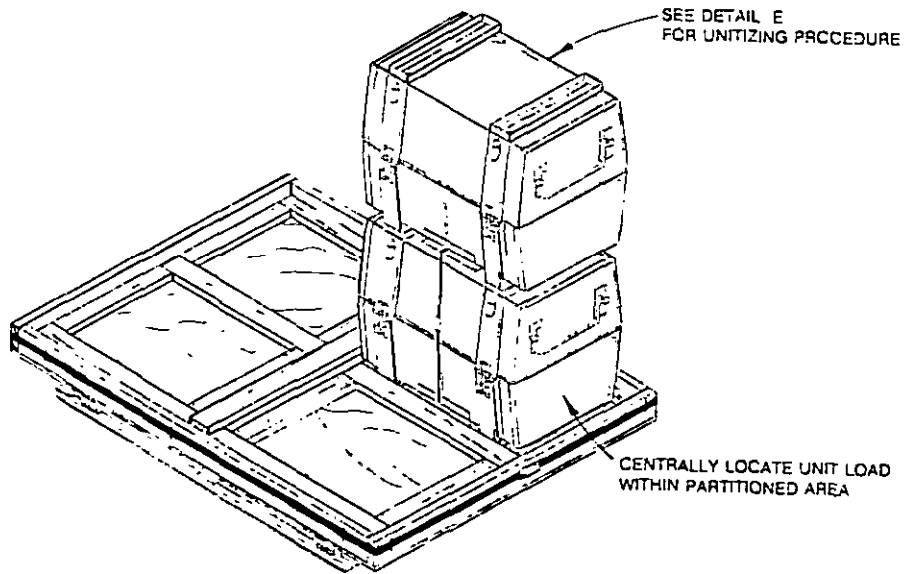

VIEW C

REF:
BREATHER VALVE AND HUMIDITY INDICATOR
TO FACE OUTWARD AS SHOWN. 8PL

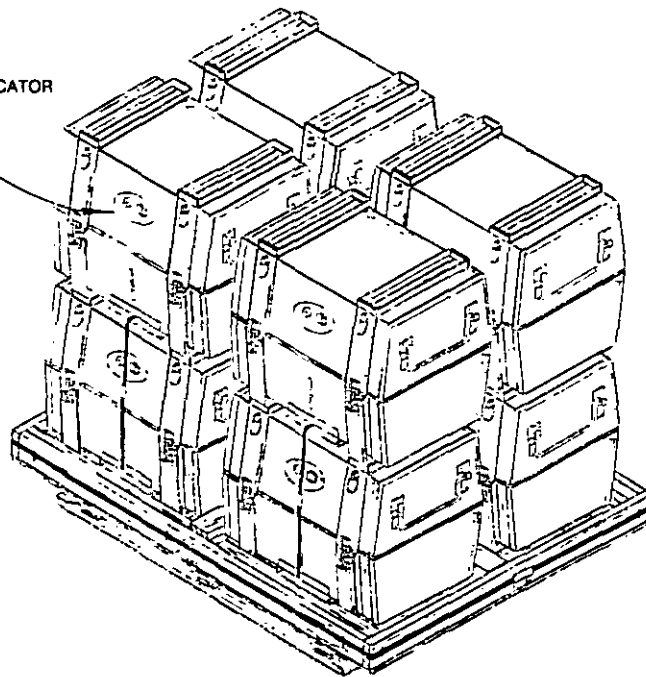

VIEW D
COMPLETED ARRANGEMENT
(4 UNIT LOADS)

UNITIZING PROCEDURE (CONTAINER)

- a. CAREFULLY POSITION 1 CONTAINER ON TOP OF ANOTHER. MAKE SURE TO ENGAGE THE STACKING FEATURE AS SHOWN IN DETAIL E.
- b. POSITION ONE STRAP, ITEM 4, THROUGH THE FORK POCKETS OF THE BOTTOM CONTAINER AND UP THROUGH THE FORK POCKETS OF THE 2nd CONTAINER. TENSION AND DOUBLE NOTCH SEAL.

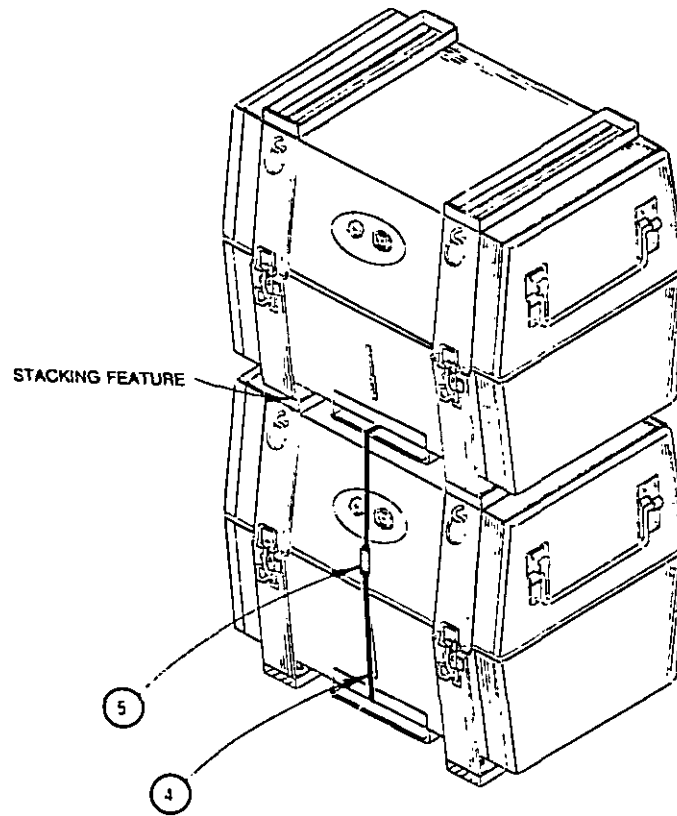
**DETAIL E**