

MIL-STD-1312-11A
19 OCTOBER 1984

SUPERSEDING
MIL-STD-1312 (In part)
31 MAY 1967
DOD - STD - 1312 - 11
19 OCTOBER 1983

MILITARY STANDARD

FASTENER TEST METHODS

METHOD 11,

TENSION FATIGUE



FSC 53GP

MIL-STD-1312-11A

DEPARTMENT OF DEFENSE
WASHINGTON, DC 20301

Fastener Test Methods, Method 11, Tension Fatigue

MIL-STD-1312-11A

1. This Military Standard is approved for use by all Departments and Agencies of the Department of Defense.

2. Beneficial comments (recommendations, additions, deletions) and any pertinent data which may be of use in improving this document should be addressed to: Commanding Officer, Naval Air Engineering Center, Systems Engineering and Standardization Department (SESD), Code 93, Lakehurst, NJ 08733, by using the self-addressed Standardization Document Improvement Proposal (DD Form 1426) appearing at the end of this document or by letter.

MIL-STD-1312-11A

FOREWORD

This standard sets forth standard test procedures for determining tension fatigue of bolts, screws and nuts at room temperature.

TABLE OF CONTENTS

<u>Paragraph</u>		<u>Page</u>
1.	SCOPE	1
1.1	Applicability	1
2.	REFERENCED DOCUMENTS	1
2.1	Government documents	1
2.1.1	Specifications, standards and handbooks	1
2.2	Other publications	1
3.	DEFINITIONS	2
4.	GENERAL REQUIREMENTS	2
4.1	Test apparatus	2
4.1.1	Fixtures	2
4.1.2	Static alignment.....	2
4.1.2.1	Spacer	2
4.1.2.2	Test nuts	2
4.1.2.3	Test bolts	2
4.1.2.4	Limitations	2
4.1.2.5	Fixture alignment	9
4.1.2.6	Threaded adapters	9
4.2	Test specimens	9
4.2.1	Bolts	9
4.2.2	Testing of nuts	9
4.2.3	Nut test results	9
5.	DETAIL REQUIREMENTS	9
5.1	Test procedures	9
5.1.1	Bolts	9
5.1.1.1	Tension bolts	9
5.1.1.2	Shear bolts	9
5.1.1.3	Flush head bolts	10
5.2	Test conditions	10
5.2.1	Torque	10
5.2.2	Load level	10
5.2.3	Load ratio	10
5.2.4	Test speed	10
6.	NOTES	10
6.1	Test report	10

MIL-STD-1312-11A

FIGURES

<u>Figure</u>		<u>Page</u>
1.	Typical test fixture arrangement	3
2.	Nut, fatigue test, room temperature, for tension bolts	5
3.	Nut, fatigue test, room temperature, for shear bolts	7

TABLES

<u>Table</u>		<u>Page</u>
I.	List of items called out on figure 1	4
II.	List of dimensions for figure 2	6
III.	List of dimensions for figure 3	8

MIL-STD-1312-11A

1. SCOPE

1.1 Applicability. This test method establishes the procedure and equipment to be used for room temperature tension fatigue testing of bolts, screws and nuts.

2. REFERENCED DOCUMENTS

2.1 Government documents.

2.1.1 Specifications, standards and handbooks. Unless otherwise specified, the following specifications, standards and handbooks of the issue listed in the current Department of Defense Index of Specifications and Standards (DoDISS) and the supplement thereto (if applicable), form a part of this standard to the extent specified herein.

SPECIFICATIONS

MILITARY

MIL-I-6868	Inspection Process, Magnetic Particle
MIL-H-6875	Heat Treatment of Steels (Aircraft Practice), Process for
MIL-S-8879	Screw Threads, Controlled Radius Root with Increased Minor Diameter, General Specification for
MIL-C-15074	Corrosion Preventive, Fingerprint Remover

STANDARDS

MILITARY

MIL-STD-1312	Fastener Test Methods
--------------	-----------------------

(Copies of specifications, standards, handbooks, drawings and publications required by contractors in connection with specific acquisition functions should be obtained from the contracting activity or as directed by the contracting officer.)

2.2 Other publications. The following document(s) forms a part of this specification to the extent specified herein. The issues of the documents which are indicated as DOD adopted shall be the issue in the current DoDISS and the supplement thereto, if applicable.

AMERICAN NATIONAL STANDARDS INSTITUTE (ANSI)

ANSI B46.1	Surface Texture (Surface Roughness, Waviness, and Lay)
------------	---

(Application for copies should be addressed to the American National Standards Institute, 1430 Broadway, New York, NY 10018.)

AMERICAN SOCIETY FOR TESTING AND MATERIALS (ASTM)

ASTM E 4 Load Verification of Testing Machines

ASTM E 74 Verification of Calibration Devices for
Verifying Testing Machines

(Applications for copies should be addressed to the American Society for Testing and Materials, 1916 Race Street, Philadelphia, PA 19103.)

3. DEFINITIONS

Not applicable.

4. GENERAL REQUIREMENTS

4.1 Test apparatus.

4.1.1 Fixtures. A typical test fixture arrangement for fatigue testing of fastener is illustrated in figure 1 and table I. Procedure to verify proper fatigue test machine and fixture alignment and cyclic-load application for the testing machine can be found in MIL-STD-1312 Appendix C.

4.1.2 Static alignment. Static alignment of each fatigue test machine shall be verified to ensure meeting the alignment requirements of MIL-STD-1312, Appendix C.

4.1.2.1 Spacer. A spacer conforming to figure 1(c) may be used under the head of protruding head fasteners to provide clearance for the fastener head-to-shank fillet radius. Plain flat spacers may be used under the nut.

4.1.2.2 Test nuts. The fatigue test nuts shall conform to figure 2 and table II or figure 3 and table III. Threaded adapters may be used on shear fasteners through one-half inch diameter or tension fasteners too short to test with nuts on available fixtures. Locking devices are not permitted. Type A or B nuts may be used for testing bolts under 260 ksi.

A fatigue test nut may be reused for not more than five tests, provided the nut meets the dimensional requirements and has not been damaged by a previous test and the same nut is used for testing the same lot of bolts. For referee tests, only unused nuts shall be used.

4.1.2.3 Test bolts. Test bolts or studs shall not be reused.

4.1.2.4 Limitations. Universal joints or spherical seats shall not be used anywhere on the test fixtures.

MIL-STD-1312-11A

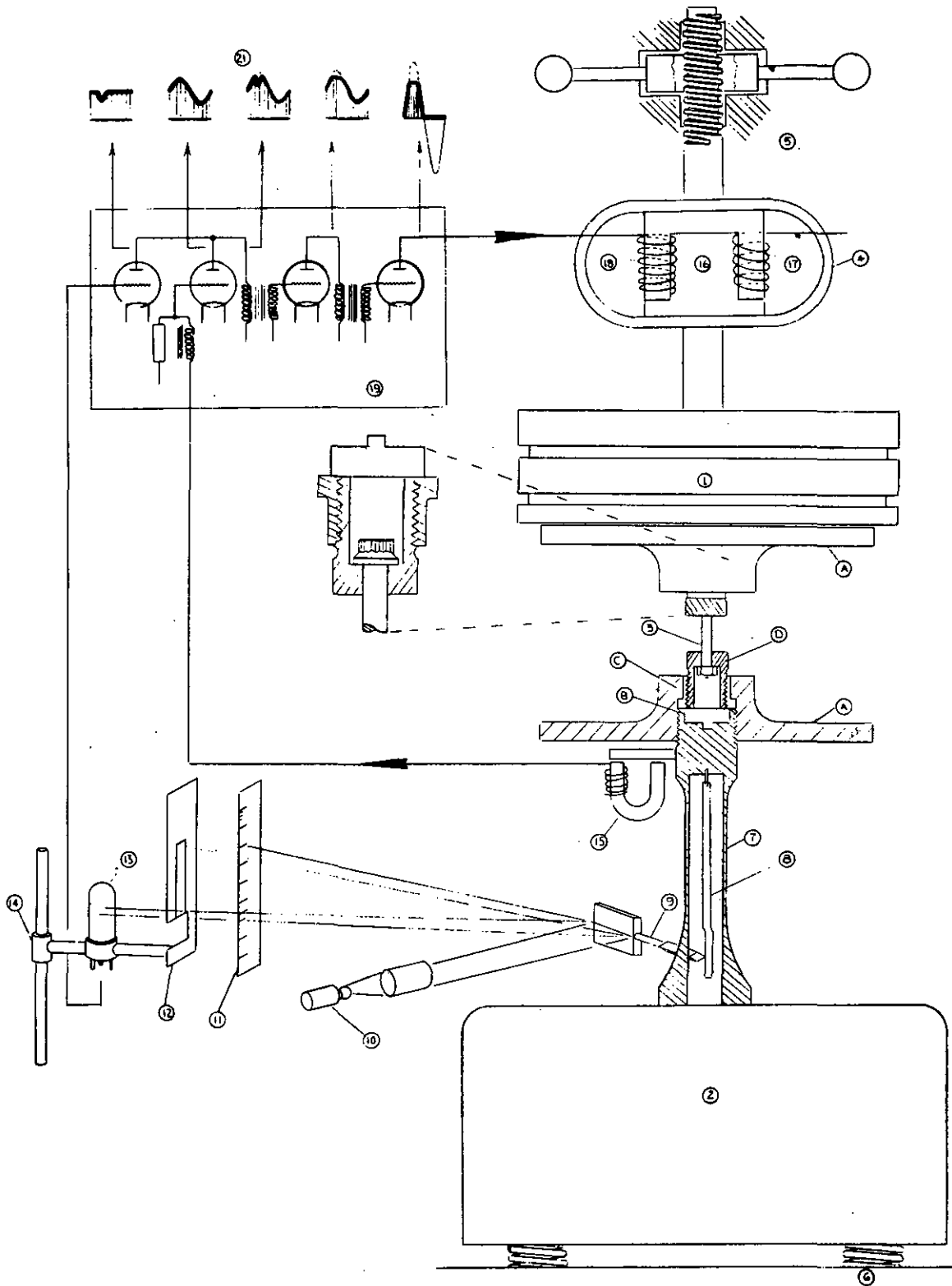

NOTE:

1. The list of numbered and lettered items appear in table I.

FIGURE 1. Typical test fixture arrangement.

MIL-STD-1312-11A

TABLE I. List of items called out on figure 1.

Item	Description	Item	Description
1	Main mass	15	Impulse generator
2	Opposing mass	16	Driving magnet
3	Specimen (bolt)	17	Premagnetization (dc)
4	Preload spring	18	Main coils (ac)
5	Adjusting spindle	19	Tube amplifier
6	Spring supports	20	Phase adjustment
7	Dynamometer	21	Current waveforms With amplitude adjustment
8	Comparison bar		--- Without amplitude adjust
9	Mirror bar	A	Fixture preloading gear nut
10	Optical projector	B	Fixture stop plate
11	Dynamometer scale	C	Cup holding adapter
12	Diaphragm	D	Bolt loading cup
13	Photocell		
14	Photocell slide		

MIL-STD-1312-11A

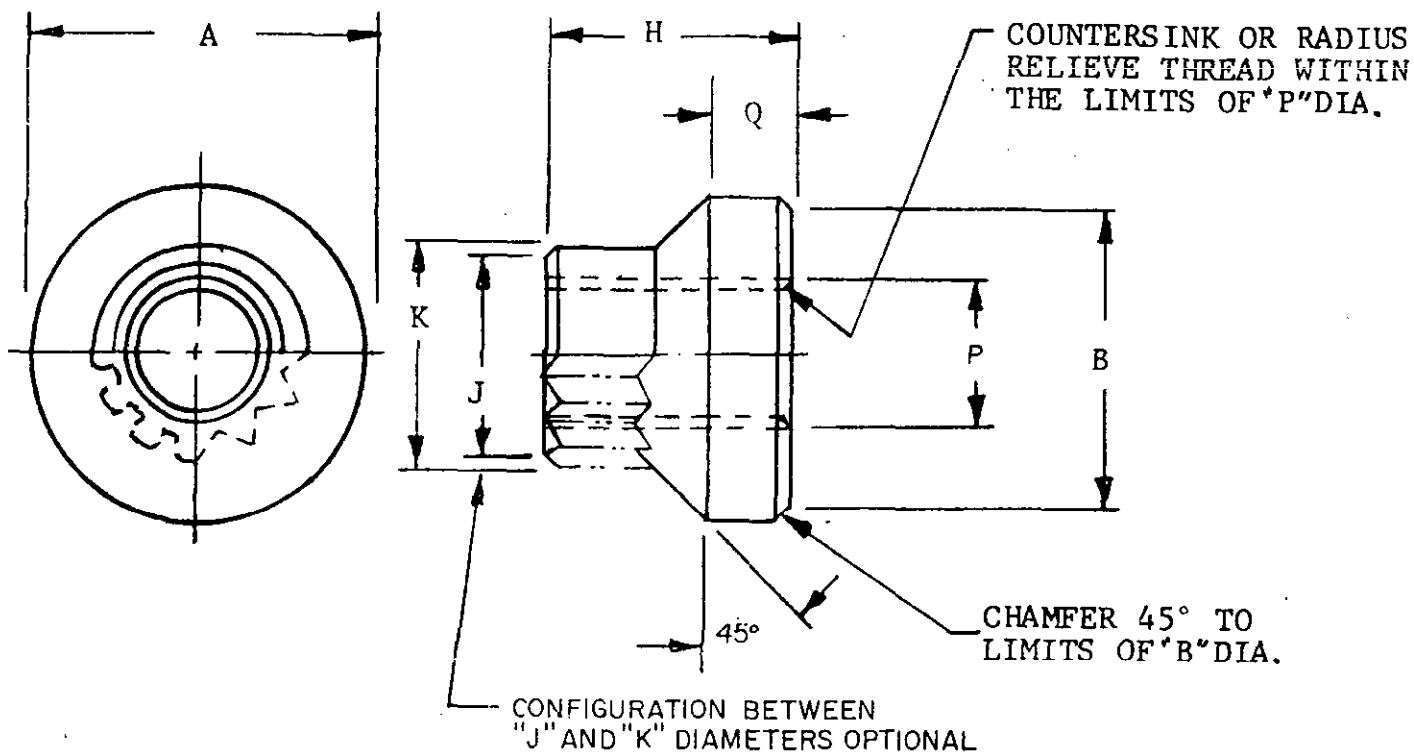

NOTES:

1. Material: Alloy steel.
2. Hardness: Type A - HRC 27-32 for testing bolts rated below 260 ksi
Type B - HRC 36-42 for testing bolts rated 260 ksi and higher
3. Heat treat per MIL-H-6875.
4. Surface texture: 125 microinches per ANSI B46.1.
5. Protective coating: Rust preventive oil (MIL-C-15074) to be removed before testing.
6. Residual traces of cadmium permitted on nuts retapped to remove locking device.
7. Magnetic particle inspect per MIL-I-6868; omit identification.
8. Threads per MIL-S-8879.
9. Concentricity: All diameters to be concentric within 0.005 FIM.
10. Squareness: Bearing surface to thread P.D. within 0.003 FIM.
11. Bearing surface to be concave within "Y" FIM.
12. Dimensions in inches unless otherwise specified (see table II).
13. Break all sharp edges.
14. Tolerances: Three decimals ± 0.010 unless otherwise noted;
Angular $\pm 2^\circ$.

FIGURE 2. Nut, fatigue test, room temperature, for tension bolts.

MIL-STD-1312-11A

TABLE II. List of dimensions for figure 2.

Thread UNJF-3B	A ref (in.)	B min (in.)	H +0.000 -0.030 (in.)	J min (in.)	K max (in.)	P max (in.)	Q ± 0.010 (in.)	Y	
								Max (in.)	Min (in.)
0.190-32	0.355	0.325	0.242	0.252	0.290	0.236	0.058	0.003	0.0005
0.250-28	0.481	0.441	0.349	0.380	0.434	0.296	0.082	0.003	0.0005
0.312-24	0.606	0.566	0.411	0.445	0.507	0.359	0.101	0.003	0.0005
0.375-24	0.740	0.700	0.497	0.509	0.580	0.421	0.122	0.003	0.0005
0.437-20	0.863	0.823	0.579	0.572	0.651	0.484	0.143	0.004	0.001
0.500-20	0.995	0.955	0.665	0.638	0.724	0.546	0.162	0.004	0.001
0.562-18	1.129	1.079	0.747	0.767	0.868	0.609	0.184	0.004	0.001
0.625-18	1.245	1.195	0.864	0.831	0.940	0.671	0.201	0.004	0.001
0.750-16	1.513	1.463	1.005	0.961	1.085	0.796	0.247	0.004	0.001
0.875-14	1.770	1.720	1.175	1.118	1.301	0.921	0.288	0.005	0.001
1-14NS	2.040	1.980	1.355	1.284	1.446	1.046	0.330	0.005	0.001
1.000-12	2.040	1.980	1.355	1.284	1.446	1.046	0.330	0.005	0.001
1.125-12	2.285	2.225	1.535	1.477	1.663	1.171	0.372	0.006	0.001
1.250-12	2.555	2.495	1.715	1.671	1.879	1.296	0.414	0.007	0.001
1.375-12	2.850	2.760	1.905	1.800	2.023	1.421	0.456	0.007	0.001
1.500-12	3.090	3.030	2.085	1.929	2.167	1.549	0.497	0.008	0.001

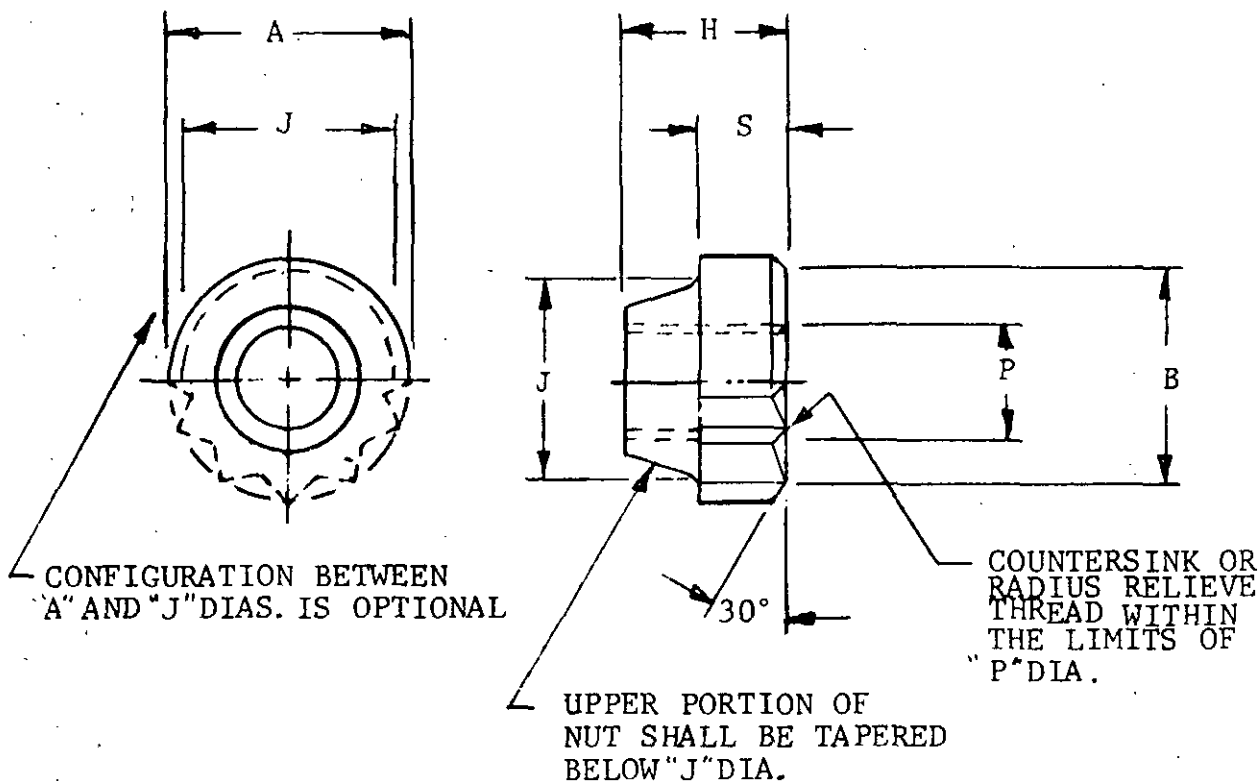

NOTES:

1. Material: Alloy steel.
2. Hardness: HRC 36-42.
3. Heat treat per MIL-H-6875.
4. Surface texture: 125 microinches per ANSI B46.1.
5. Protective Coating: Rust preventive oil (MIL-C-15074) to be removed before testing.
6. Residual traces of cadmium permitted on nuts retapped to remove locking device.
7. Magnetic particle inspect per MIL-I-6868; omit identification.
8. Threads per MIL-S-8879.
9. Concentricity: All diameters to be concentric within 0.005 FIM.
10. Squareness: Bearing surface to thread P.D. within 0.003 FIM.
11. Bearing surface to be concave within "Y" FIM.
12. Dimensions in inches unless otherwise specified (see table III).
13. Break all sharp edges.
14. Tolerances: Three decimals ± 0.010 unless otherwise noted;
Angular $\pm 2^\circ$.

FIGURE 3. Nut fatigue test, room temperature, for shear bolts.

MIL-STD-1312-11A

TABLE III. List of dimensions for figure 3.

Thread UNJF-3B	A max (in.)	J min (in.)	H +0.000 -0.030 (in.)	B min (in.)	S ref (in.)	P max (in.)	Y	
							Max (in.)	Min (in.)
0.190-32	0.434	0.380	0.151	0.367	0.057	0.210	0.003	0.0005
0.250-28	0.507	0.445	0.199	0.430	0.086	0.270	0.003	0.0005
0.312-24	0.580	0.509	0.253	0.492	0.120	0.332	0.003	0.0005
0.375-24	0.651	0.572	0.313	0.553	0.158	0.405	0.003	0.0005
0.437-20	0.797	0.703	0.373	0.679	0.189	0.467	0.004	0.001
0.500-20	0.868	0.767	0.439	0.741	0.220	0.530	0.004	0.001
0.562-18	1.013	0.896	0.509	0.865	0.262	0.597	0.004	0.001
0.625-18	1.085	0.961	0.584	0.928	0.307	0.660	0.004	0.001
0.750-16	1.229	1.089	0.750	1.052	0.505	0.781	0.004	0.001
0.875-14	1.446	1.284	0.925	1.239	0.630	0.906	0.005	0.001
1-14NS	1.663	1.477	1.115	1.427	0.776	1.031	0.005	0.001
1.000-12	1.663	1.477	1.115	1.427	0.776	1.031	0.005	0.001
1.125-12	1.879	1.671	1.309	1.614	0.712	1.156	0.006	0.001
1.250-12	2.096	1.865	1.528	1.801	0.832	1.281	0.007	0.001
1.375-12	2.312	2.058	1.761	1.988	0.960	1.406	0.007	0.001
1.500-12	2.528	2.253	2.010	2.176	1.097	1.531	0.008	0.001

MIL-STD-1312-11A

4.1.2.5 Fixture alignment. The fixtures used shall be capable of holding the fasteners in conformance with the alignment requirements specified in MIL-STD-1312, Appendix C.

4.1.2.6 Threaded adapters. The hardness of threaded adapters shall be as specified on figure 2.

4.2 Test specimens.

4.2.1 Bolts. Protruding head tensile bolts shall be tested using the fatigue test nuts as shown on figure 2 or the threaded adapter. Flush head bolts and protruding head shear bolts shall be tested using the fatigue test nuts (figures 2 and 3) or threaded adapters. Threaded adapters shall be replaced when they become damaged as determined by visual inspection and when they go out of tolerance. When adapters are used for referee tests, they shall be unused adapters. (Note: Fatigue tests are not applicable to parts with cross-drilled threads.)

For bolts having coarse or special threads, the fatigue test nut shall be as specified in the procurement specification.

The recommended minimum grip length for test bolts shall be twice the nominal diameter.

4.2.2 Testing of nuts. Nuts shall be tested on bolts as specified in the procurement specification. Nuts shall be assembled on the bolts with no less than two full threads exposed between the nut and the end of the bolt.

A sample of each lot of bolts or studs, used for testing nuts, shall first be tested in accordance with this test method using test nuts in figure 2 in order to determine their reliability.

4.2.3 Nut test results. Fracture in the threads of the bolt or nut and failure to support the test load shall constitute a valid test conclusion. Fracture of the bolt in any other location shall not be considered a valid test conclusion and shall be repeated using a new nut and bolt.

5. DETAIL REQUIREMENTS

5.1 Test procedures.

5.1.1 Bolts.

5.1.1.1 Tension bolts. Tension bolts shall be assembled so that a minimum of two and a maximum of three threads are exposed between the nut bearing face and bolt thread run out.

5.1.1.2 Shear bolts. Shear bolts shall be assembled with a minimum of one-half and a maximum of one thread exposed between the nut bearing face and the bolt thread run out.

MIL-STD-1312-11A

5.1.1.3 Flush head bolts. Flush head bolts shall be checked for uniform bearing between the bolt head and the loading cup in which it is to be tested. There shall be no contact in the area of the head-shank fillet radius.

5.2 Test conditions.

5.2.1 Torque. There shall be no tensile stress in the fasteners due to torque or other installation procedures.

5.2.2 Load level. The fatigue test load shall be as specified in the applicable procurement document or product specification.

5.2.3 Load ratio. Unless otherwise specified, the low load shall be one-tenth of the high-load level ($R = 0.1$).

5.2.4 Test speed. The test speed shall not exceed 12,500 cycles per minute. Excessive heat may be generated when testing high-strength fasteners at high frequencies. In this case the test speed shall be reduced to ensure that the maximum (test fasteners) temperature does not exceed 150°F.

6. NOTES

6.1 Test report. The test report shall contain the following:

- a. Fastener description.
 1. Part number and fastener diameter.
 2. Lot identification.
 3. Material.
 4. Heat treatment.
 5. Grip length.
 6. Mating part.
 7. Measured fastener diameter.
- b. Test Machine.
 1. Model and serial number.
 2. Calibration date.
- c. Test load.

MIL-STD-1312-11A

- d. Test speed.
- e. Test duration.
- f. Type of failure.
- g. Cause and duration of any interruption during test.
- h. Installation procedure.
- i. Results of all inspections.

Custodians:

Army - AV
Navy - AS
Air Force - 11

Preparing activity:

Navy - AS
(Project No. 53GP-0143-11)

Review activities:

Army - AV, AR
Navy - AS, SH
Air Force - 11
DLA - IS

INSTRUCTIONS: In a continuing effort to make our standardization documents better, the DoD provides this form for use in submitting comments and suggestions for improvements. All users of military standardization documents are invited to provide suggestions. This form may be detached, folded along the lines indicated, taped along the loose edge (*DO NOT STAPLE*), and mailed. In block 5, be as specific as possible about particular problem areas such as wording which required interpretation, was too rigid, restrictive, loose, ambiguous, or was incompatible, and give proposed wording changes which would alleviate the problems. Enter in block 6 any remarks not related to a specific paragraph of the document. If block 7 is filled out, an acknowledgement will be mailed to you within 30 days to let you know that your comments were received and are being considered.

NOTE: This form may not be used to request copies of documents, nor to request waivers, deviations, or clarification of specification requirements on current contracts. Comments submitted on this form do not constitute or imply authorization to waive any portion of the referenced document(s) or to amend contractual requirements.

(Fold along this line)

(Fold along this line)

DEPARTMENT OF THE NAVY
Commanding Officer
Naval Air Engineering Center
Systems Engineering and Standardization Department
(SESD), Code 93
Lakehurst, NJ 08733



NO POSTAGE
NECESSARY
IF MAILED
IN THE
UNITED STATES

OFFICIAL BUSINESS
PENALTY FOR PRIVATE USE \$300

BUSINESS REPLY MAIL

FIRST CLASS PERMIT NO. 12503 WASHINGTON D. C.

POSTAGE WILL BE PAID BY THE DEPARTMENT OF THE NAVY

Commanding Officer
Naval Air Engineering Center
Systems Engineering and Standardization Dept.
(SESD), Code 93
Lakehurst, NJ 08733



STANDARDIZATION DOCUMENT IMPROVEMENT PROPOSAL

(See Instructions - Reverse Side)

1. DOCUMENT NUMBER MIL-STD-1312-11A		2. DOCUMENT TITLE Fastener Test Methods - Method 11 - Tension Fatigue	
3a. NAME OF SUBMITTING ORGANIZATION		4. TYPE OF ORGANIZATION (Mark one)	
b. ADDRESS (Street, City, State, ZIP Code)		<input type="checkbox"/> VENDOR	
		<input type="checkbox"/> USER	
		<input type="checkbox"/> MANUFACTURER	
		<input type="checkbox"/> OTHER (Specify): _____	
5. PROBLEM AREAS			
a. Paragraph Number and Wording:			
b. Recommended Wording:			
c. Reason/Rationale for Recommendation:			
6. REMARKS			
7a. NAME OF SUBMITTER (Last, First, MI) - Optional		b. WORK TELEPHONE NUMBER (Include Area Code) - Optional	
c. MAILING ADDRESS (Street, City, State, ZIP Code) - Optional		8. DATE OF SUBMISSION (YYMMDD)	

(TO DETACH THIS FORM, CUT ALONG THIS LINE.)