

NOT MEASUREMENT SENSITIVE

MIL-STD-1223AB  
1 August 1990  
SUPERSEDING  
MIL-STD-1223AA  
15 January 1989

MILITARY STANDARD  
NONTACTICAL WHEELED VEHICLES  
TREATMENT, PAINTING, IDENTIFICATION  
MARKING AND DATA PLATE STANDARDS



AMSC N/A

FSC-23GP

DISTRIBUTION STATEMENT A. Approved for public release; distribution is unlimited.

MIL-STD-1223AB

FOREWORD

1. This Military Standard is approved for use by all Departments and Agencies of the Department of Defense.

2. Beneficial comments (recommendations, additions, deletions) and any pertinent data which may be of use in improving this document should be addressed to: US Army Tank-Automotive Command, ATTN: AMSTA-URD, Warren, MI 48397-5000, by using the self-addressed Standardization Document Improvement Proposal (DD Form 1426) appearing at the end of this document or by letter.

## MIL-STD-1223AB

## CONTENTS

Paragraph		Page
1.	SCOPE . . . . .	1
1.1	Purpose . . . . .	1
1.2	Exemptions . . . . .	1
2.	APPLICABLE DOCUMENTS . . . . .	2
2.1	Government documents . . . . .	2
2.1.1	Specifications, standards and handbooks . . . . .	2
2.1.2	Other Government documents . . . . .	2-3
2.2	Non-Government publications . . . . .	3
2.3	Order of precedence . . . . .	3
3.	DEFINITIONS . . . . .	4
4.	GENERAL REQUIREMENTS . . . . .	5
4.1	Treatment, painting, marking, and data plates . . . . .	5
4.1.1	Standard identification marking . . . . .	5
4.1.2	Special markings . . . . .	5
4.1.3	Concealed markings . . . . .	5
5.	DETAILED REQUIREMENTS . . . . .	6
5.1	Treatment and painting . . . . .	6
5.1.1	Trucks and truck tractors . . . . .	6
5.1.1.1	Chassis frame, undercarriage and underbody . . . . .	6
5.1.1.2	Truck body on chassis . . . . .	7
5.1.1.3	Semigloss and lusterless colors . . . . .	7
5.1.2	Cleaning, treatment and priming: truck body on chassis, trailers, semitrailers and dollies . . . . .	7
5.1.3	Salt spray resistance: truck body on chassis, trailers, semitrailers and dollies . . . . .	7
5.1.4	Certification: truck bodies on chassis, trailers, semitrailers and dollies . . . . .	8
5.1.5	Paint application: truck chassis on body, trailers, semitrailers and dollies . . . . .	8
5.1.6	Trailers, semitrailers and dollies . . . . .	8
5.1.6.1	Semigloss and lusterless colors: trailers, semitrailers and dollies . . . . .	8
5.1.6.2	Appurtenances; trailers, semitrailers and dollies . . . . .	9
5.1.7	School bus body . . . . .	9
5.1.7.1	Bus exterior . . . . .	9-10
5.1.7.2	Bus interior . . . . .	10
5.1.8	Automobile sedans, station wagons, scooters, snowmobiles, and motorcycles . . . . .	10

## MIL-STD-1223AB

CONTENTS - Continued

		<u>Page</u>
Paragraph 5.1.9	Exterior colors . . . . .	10-11
5.1.9.1	Army and Army National Guard exterior colors	11
5.1.9.2	Navy, Marine Corps and Defense Logistics Agency exterior colors . . . . .	11
5.2	Wood and plywood preservative treatment . . .	11-12
5.3	Rustproofing . . . . .	12
5.4	Identification markings for Army and Army National Guard vehicles . . . . .	12
5.4.1	Rear window or bumper markings . . . . .	12
5.4.2	Location of rear window or rear bumper markings . . . . .	12-13
5.5	Identification markings, other services . . .	13
5.5.1	Marking locations . . . . .	13
5.5.1.1	Sides of vehicle . . . . .	13-14
5.5.1.2	Rear of vehicle . . . . .	14
5.5.1.3	Front of vehicle . . . . .	15
5.5.2	Marking material . . . . .	15
5.5.2.1	Removable markings . . . . .	15
5.5.3	Marking colors . . . . .	15
5.5.3.1	Army and Army National Guard marking colors . . . . .	15
5.5.3.2	Navy marking colors . . . . .	15
5.5.3.3	Air Force marking colors . . . . .	16
5.5.3.4	Marine Corps marking colors . . . . .	16
5.5.3.5	Defense Logistic Agency marking colors . . .	16
5.5.3.6	Department of Defense marking colors . . .	16
5.6	Data plates . . . . .	16
5.6.1	Nameplate . . . . .	16-17
5.6.2	Parts data plate or decal . . . . .	17
5.6.3	Data plate mounting . . . . .	17-18
6	NOTES . . . . .	18
6.1	Intended use . . . . .	18
6.2	Issue of DODISS . . . . .	18
6.3	Subject term (key word listing) . . . . .	18
6.4	Changes from previous issue . . . . .	18

## MIL-STD-1223AB

CONTENTS - Continued

## FIGURES

	<u>Page</u>
Figure 1 Style of vehicle marking letters . . . . .	19
2 Size and spacing of non-tactical vehicle side markings . . . . .	20
3 Arrangement of Army rear window or bumper markings . .	21
4 Arrangement of Army marking on front and rear plates . .	22
5 Arrangement of Navy side marking . . . . .	23
6 Arrangement of Air Force side marking . . . . .	24
7 Arrangement of Marine Corps side marking . . . . .	25
8 Arrangement of Defense Logistics Agency side marking . .	26
9 Arrangement of Department of Defense side marking . . .	27
10 Alternate arrangement of Department of Defense side marking . . . . .	28
11 Sedan with Army markings . . . . .	29
12 Station wagon with Air Force markings . . . . .	30
13 Multistop delivery truck with Navy markings . . . . .	31
14 Four door cab pickup truck with Air Force markings . . .	32
15 Truck tractor with Marine Corps markings . . . . .	33
16 Dump truck with Defense Logistics Agency markings . . .	34
17 Stake and platform truck with Department of Defense markings . . . . .	35
18 Utility truck with Army markings . . . . .	36
19 Bus with Navy markings . . . . .	37
20 Van type semitrailer with Army markings . . . . .	38
21 Lowbed semitrailer with Air Force markings . . . . .	39
22 Four wheel stake trailer with Air Force markings . . . .	40
23 Scooter with Army markings . . . . .	41

## MIL-STD-1223AB

### 1 SCOPE

1.1 Purpose. This standard prescribes requirements for treatment, painting, identification marking and data plates for self-propelled and towed vehicles procured for general nontactical use by the Government.

1.2 Exemptions. Special purpose vehicles are exempt from the general provisions of this standard. Acquisition documents should indicate departmental requirements for these vehicles.

## MIL-STD-1223AB

## 2 APPLICABLE DOCUMENTS

2.1 Government documents.

\* 2.1.1 Specifications, standards, and handbooks. The following specifications, standards, and handbooks form a part of this document to the extent specified herein. Unless otherwise specified, the issues of these documents are those listed in the issue of the Department of Defense Index of Specifications and Standards (DODISS) and supplement thereto, cited in the solicitation (see 6.2).

## SPECIFICATIONS

## FEDERAL

- |   |          |                                                                                       |
|---|----------|---------------------------------------------------------------------------------------|
|   | L-S-300  | - Sheeting and Tape, Reflective: Nonexposed Lens, Adhesive Backing.                   |
|   | TT-L-32  | - Lacquer, Cellulose Nitrate, Gloss, for Aircraft Use.                                |
| * | TT-E-489 | - Enamel, Alkyd, Gloss, (Low VOC Content).                                            |
| * | TT-P-664 | - Primer Coating, Alkyd, Corrosion-Inhibiting, Lead and Chromate Free, VOC Compliant. |

## MILITARY

- |  |             |                                                                                               |
|--|-------------|-----------------------------------------------------------------------------------------------|
|  | MIL-P-14553 | - Primer Coating, Dipping Automotive.                                                         |
|  | MIL-C-21067 | - Coating Compound, Synthetic Rubber, for Exposed Steel Surfaces.                             |
|  | MIL-M-43719 | - Marking Materials and Markers, Adhesive, Elastomeric, Pigmented; General Specification for. |

## STANDARDS

## FEDERAL

- |  |             |                                                      |
|--|-------------|------------------------------------------------------|
|  | FED-STD-297 | - Rustproofing of Commercial (Nontactical) Vehicles. |
|  | FED-STD-595 | - Colors.                                            |

(Unless otherwise indicated, copies of federal and military specifications, standards and handbooks are available from the Naval Publications and Forms Center, Military Specifications and Standards, Bldg. 4D, 700 Robbins Avenue, Philadelphia, PA 19111-5094.)

\* 2.1.2 Other Government documents, drawings, and publications. The following other Government documents, drawings and publications form a part of this document to the extent specified herein. Unless otherwise specified, the issues are those cited in the solicitation.

MIL-STD-1223AB

\* DEPARTMENT OF DEFENSE

Department of Defense Index of Specifications and Standards (DODISS).

(Copies of the DODISS are available on a yearly subscription basis either from the Government Printing Office for hard copy, or microfiche copies are available from the Director, Navy Publications and Printing Service Office, 700 Robbins Avenue, Philadelphia, PA 19111-5093.)

DEPARTMENT OF TRANSPORTATION (DoT)

Federal Motor Vehicle Safety Standards.

(Application for copies of DoT publications should reference the Code of Federal Regulations, 49 CFR, and the Federal Register, and should be addressed to the Superintendent of Documents, U.S. Government Printing Office, Washington, D.C. 20402.)

\* 2.2 Non-Government publications. The following documents form a part of this document to the extent specified herein. Unless otherwise specified, the issues of the documents which are DoD adopted are those listed in the issue of the DODISS cited in the solicitation. Unless otherwise specified, the issues of documents not listed in the DODISS are the issues of the documents cited in the solicitation (see 6.2).

AMERICAN SOCIETY FOR TESTING AND MATERIALS (ASTM)

ASTM Designation A123 - Zinc (Hot-Dipped) Galvanized Coatings on Iron and Steel Products

ASTM Designation A153 - Zinc Coating (Hot-Dip) on Iron and Steel Hardware (DOD adopted).

ASTM Designation B117 - Method of Salt Spray (Fog) Testing.

(Application for copies of ASTM publications should be addressed to the American Society for Testing and Materials, 1916 Race Street, Philadelphia, PA 19103.)

\* (Non-Government standards and other publications are normally available from the organizations that prepare or distribute the documents. These documents also may be available in or through libraries or other informational services.)

\* 2.3 Order of precedence. In the event of a conflict between the text of this document and the references cited herein, the text of this standard shall take precedence. Nothing in this document, however, supersedes applicable laws and regulations unless a specific exemption has been obtained.



MIL-STD-1223AB

3 DEFINITIONS

Not applicable.

## MIL-STD-1223AB

### 4 GENERAL REQUIREMENTS

4.1 Treatment, painting, marking and data plates. As required and specified by the applicable acquisition document, the treatment, painting, marking and data plates shall be applied to the vehicle as specified herein for the appropriate military service. Unless otherwise specified, all color numbers cited in this standard shall conform to FED-STD-595.

4.1.1 Standard identification marking. The identification marking applied to the vehicle shall consist of the departmental or agency identification, registration number, and legend.

4.1.2 Special markings. Except as specified herein the unit identification and other special markings, such as national symbol, military police, armed services police, and safety markings, shall be applied upon receipt by the using service.

\* 4.1.3 Concealed markings. Vehicles requiring concealed markings in accordance with contractual provisions shall be furnished with a nameplate only, permanently attached to the underside of the rear trunk lid, or if not so equipped, on another concealed but readily accessible interior surface such as on the inside of the map compartment lid, or the underside of the hood.

## MIL-STD-1223AB

## 5 DETAILED REQUIREMENTS

\* 5.1 Treatment and painting. All weld slag and rust shall be removed prior to treatment. Weld spatter on readily visible, accessible areas shall be removed prior to treatment. Except as otherwise specified herein (see 5.1.1 through 5.1.8), all exposed metal surfaces shall be completely cleaned, primed, and painted in the exterior color specified. Except as otherwise specified herein (see 5.1.1 through 5.1.8), all sheet metal interior surfaces shall be painted or, when not exposed for painting, shall be treated or coated to resist corrosion. Otherwise, painting and preparation for painting shall be with the manufacturer's current materials and according to current processes. Stainless steel surfaces to be painted shall be cleaned with a solvent or dilute phosphoric acid solution followed by a basic zinc chromate vinyl butyral wash coat prior to painting. The top surface of the dash panel shall minimize reflected light by using lusterless paint, non-reflective paint, a pebbled surface or other textured pattern. Wooden ladder parts shall be coated with a clear protective finish. All wood parts on the vehicle that are not sealed from the atmosphere shall be painted, except; the wood decks on trailers and semitrailers shall be either completely painted or completely not painted, with no unsightly overspray on the top of the wood deck.

\* 5.1.1 Trucks and truck tractors. Except as otherwise specified in 5.1.1.3, radiator shutters; radiator grilles; reflector, light, directional signal and mirror housings; mirror support arms; bumpers; rims; wheels; and areas where paint would interfere with function, may be the manufacturer's current standard finish and color. Except as otherwise specified in 5.1.1.3, chrome plated, cadmium plated, stainless steel and anodized aluminum items need not be painted. Exhaust mufflers and exhaust pipes need not be painted. Pintle assemblies, brush guards, winches, truck tractor deck plates, and fifth wheels may be painted black. Steel fuel tanks shall be painted black or the exterior color of the vehicle. Except as otherwise specified in 5.1.1.3, aluminum fuel tanks and aluminum deck plates need not be painted.

\* 5.1.1.1 Chassis frame, undercarriage and underbody. Chassis frame parts and undercarriages may be painted black with the manufacturer's standard chassis paint. Painting of the chassis frame parts and undercarriages is required only to the extent that all areas viewed from an eye level height of two feet or more at the side, front, and rear of the completed vehicle (with body installed) are painted and free of visible rust. Painting of the chassis frame and chassis undercarriage areas not visible from these positions shall be in accordance with the chassis manufacturer's standard practice for near identical model vehicles furnished to the general public. Underbody areas of body on chassis type vehicles not visible from these positions shall be at least cleaned, treated and primed in accordance with 5.1.2. The underbody on vans shall be cleaned, treated and primed in accordance with 5.1.2 or, for aluminum vans only, shall be undercoated, at the manufacturer's option. Dump and elevating bodies shall be observed with the body in the up position.

## MIL-STD-1223AB

\* 5.1.1.2 Truck body on chassis. On maintenance bodies the interior of the cabinets shall be cleaned, treated, primed and painted the same as the exterior. The interior color of the cabinets shall be the same as the exterior, or gloss gray matching color chip No. 16187. Galvanized shelving need not be painted. The loadspace shall be the same color as the exterior. Except as otherwise specified in 5.1.1.3, bodies of bright finish aluminum, anodized aluminum surfaces, or stainless steel with a 2B or better finish shall not be painted. Except as otherwise specified in 5.1.1.3, when prepainted aluminum is furnished, the color shall be standard white. Except as otherwise specified in 5.1.1.3, aluminum van body roofs need not be painted. Platforms on stake and platform truck bodies may be painted black in lieu of the exterior color of the vehicle. When black marking is required for stake trucks, the marking background area color (the back end of the platform) shall be the same color as the exterior of the vehicle. Vehicle mounted cranes may be painted the crane manufacturers standard color. Cleaning, treating, priming and painting of the body on chassis shall conform to 5.1.2 through 5.1.5.

5.1.1.3 Semigloss and lusterless colors. When a semigloss or lusterless color is specified in acquisition documents, the body exterior, including the body roof and all exterior panels, and all chassis and body exterior trim shall match the exterior color specified.

\* 5.1.2 Cleaning and pretreatment: truck body on chassis, trailers, semitrailers, and dollies. Before painting, all truck body on chassis, trailer, semitrailer or dolly steel required to be finish painted in the exterior color specified shall be cleaned to remove all oil, grease, wax, dirt, scale, rust, and other foreign matter. The manufacturer's standard practice for cleaning ferrous or non-ferrous surfaces, as applicable, shall be used. Also, the manufacturer's standard practice for pretreatment of surfaces, as applicable, shall be used.

5.1.3 Salt spray resistance: truck body on chassis, trailers, semitrailers and dollies. Exposed non-corrugated steel sheet and plate used in the truck body on chassis, trailer, semitrailer or dolly that is required to be finish painted in the exterior color specified shall be capable of withstanding 240 hours of salt spray when tested in accordance with ASTM B117. A sheet steel specimen representative of each type of steel (plain, galvanized or galvannealed) shall be run through all steps of the cleaning and treating process, including priming. The time period between final rinse and prime painting shall be representative of the maximum period that will be encountered during production. The sample(s) shall receive no special or extraordinary care through the process. The primed specimen(s) shall be scored from corner to corner using a sharp knife. After the test, the specimen(s) panels shall exhibit no failure or rusting, including not more than 1/8-inch rust or blister creepage from the scored lines.

## MIL-STD-1223AB

5.1.4 Certification: truck bodies on chassis, trailers, semitrailers and dollies. For bodies on chassis, trailers, semitrailers and dollies containing non-corrugated sheet steel or plate required to be finish painted in the exterior color specified, a certification by the company cleaning, treating and prime painting shall be made to the government at the first production vehicle inspection. The certification shall state that tests in accordance with 5.1.3 have been run; the date the tests were run; the company running the tests; the cleaning, treatment and priming procedures used on the specimen(s) and the items under contract were the same; and the specimen(s) passed the test(s). Certification based on test results over one year old at the time the items under contract were processed will not be acceptable.

\* 5.1.5 Paint application: truck chassis on body, trailers, semitrailers and dollies. The painting shall be performed in a well-ventilated and protected area that is clean and dry. Paint shall not be applied in a moist or dusty atmosphere. The area shall have an ambient temperature of not less than plus 50 degrees Fahrenheit ( $^{\circ}$ F). The paint and surface to be coated shall be approximately the same temperature, except when hot spray is used. All painting equipment shall be properly maintained and kept free and clean of oil, dirt, scum, residue, and shall be free of moisture just prior to painting. All materials shall be thoroughly mixed and there shall be no separation of materials during painting operations. After application of the final film of paint, the surfaces shall be smooth and uniform and shall be free from grit, seeds, orange peel, fish eyes, streaks, running, sagging, wrinkles, pin holes, craters and non-uniformity of specified color.

\* 5.1.6 Trailers, semitrailers and dollies. Except as otherwise specified in 5.1.6.1, bodies of bright finish aluminum, anodized aluminum surfaces and stainless steel surfaces with a 2B or better finish shall not be painted. Except as otherwise specified in 5.1.6.1, when prepainted aluminum is furnished, the color shall be the manufacturer's standard white. Except as otherwise specified in 5.1.6.1, when the trailer or semitrailer body consists substantially of bright finish aluminum, anodized aluminum, 2B or better stainless steel, or prepainted aluminum, the exterior color of painted members may be in a matching color with a black undercarriage in lieu of being painted the exterior color specified. Except as otherwise specified in 5.1.6.1, van type semitrailer roof panels, top (upper) rails and bottom (lower) rails of galvanized copper-bearing steel or of aluminum need not be painted. The interior finish of semitrailer and trailer vans shall be as specified in the vehicle specification. Cleaning, treating, priming and painting shall conform to 5.1.2 through 5.1.5.

5.1.6.1 Semigloss and lusterless colors: trailers, semitrailers and dollies. When a semigloss or lusterless color is specified in acquisition documents, the exterior, including the roof and all exterior panels, and all chassis and body exterior trim shall match the exterior color specified.

## MIL-STD-1223AB

\* 5.1.6.2 Appurtenances, trailers, semitrailers and dollies. Except as otherwise specified in 5.1.6.1, reflector, taillight, clearance light, and directional signal housings may be the manufacturer's current standard finish and color. Except as otherwise specified in 5.1.6.1, door lock hardware, bumpers, and exterior trim shall match the exterior color specified, except that chrome-plated, cadmium-plated, stainless steel, anodized or cast aluminum, hot dipped galvanized steel and plastic surfaces need not be painted. Hot dipped galvanized steel shall be in accordance with ASTM standard A123 or A153. When cast spoke wheels are furnished, brake drums and steel hubcaps shall be painted black or the same color as the exterior of the vehicle. On disc wheels, wheel hubs, brake drums, and steel hubcaps shall be painted black or the same color as the exterior of the vehicle. Rims, locking rings, disc wheels and cast aluminum hubcaps shall be treated in accordance with the manufacturer's standard practice. The chassis frame and undercarriage parts may be painted the manufacturer's standard black in lieu of the exterior color specified.

5.1.7 School bus body. School bus body treatment and painting shall be in accordance with 5.1.1, 5.1.1.1, 5.1.1.5, 5.1.7.1, and 5.1.7.2 herein.

\* 5.1.7.1 Bus exterior. Metal parts shall be thoroughly cleaned of all rust by an acid or mechanical rust removing process. After treatment the surfaces of the parts shall show no sign of rust visible to the naked eye and shall be coated with a balanced phosphate solution containing nitrite as an accelerating agent or other phosphate solution which is known to accomplish equivalent results, until a uniform crystalline phosphate coating is obtained. The coated parts shall be rinsed with clean water followed by a second rinse with a dilute chromic acid solution and dried. Immediately after drying, the interior surfaces of the exterior and interior panels, and the exterior surfaces of the interior structural members, shall be coated in accordance with one of the following methods at the option of the contractor:

- a. A coat of primer conforming to TT-P-664, MIL-P-14553, or epoxy resin shall be applied, not less than 0.75 mil thick and baked on prior to assembly, except the underbody may be primed and air dried after assembly. The primer shall be retouched and air dried at any point or surface which becomes exposed during assembly. The exterior finish paint shall include a requisite number of coats of enamel conforming to TT-E-489 or lacquer conforming to TT-L-32 necessary to provide a film not less than 1.25 mils thick. Exterior finish paint is not required on the underbody or inside surfaces of the body skirting.
- b. An acrylic lacquer or enamel finish with a compatible primer system to assure adhesion of finish may be substituted for the primers and finish enamel specified in "a" above.

## MIL-STD-1223AB

- c. On bodies where zinc coated steel is employed for body panels and structural members, the unexposed surfaces do not require priming and the underbody and inside surfaces of the body skirting do not require priming or finish painting. All welded areas of the underbody shall have a primer coat. The primer for exposed surfaces to be color painted shall be epoxy resin, zinc chromate, or synthetic primer conforming to TT-P-664 or MIL-P-14553. The primer shall be baked. The exterior finish paint shall include a requisite number of coats of enamel conforming to TT-E-489 or lacquer conforming to TT-L-32 necessary to provide a film not less than 1.5 mils thick.
- d. Two coats of synthetic rubber compound, conforming to MIL-C-21067 Charcoate or equal, shall be baked on or properly air dried between coats. Complete coating shall be a minimum of 4.0 mils thick. Rub rails of the body, and also mating surfaces shall be double coated inside before assembly. After the body has been assembled, the entire outside of the body shall be primed. The primer shall conform to TT-P-664 or MIL-P-14553. The exterior finish paint shall be enamel conforming to TT-E-489 or lacquer conforming to TT-L-32. The exterior finish paint is not required on the underbody or inside surfaces of the body skirting.

5.1.7.2 Bus interior. The interior painting of sheet metal surfaces shall consist of at least two coats of enamel conforming to TT-E-489 or lacquer conforming to TT-L-32. The color of the interior shall coordinate with the exterior color and the color of the upholstery. All roof and side panels on the interior of the bus shall be the same color.

5.1.8 Automobile sedans, station wagons, scooters, snowmobiles, and motorcycles. Radiator grilles, bumpers, headlight and taillight rings, exterior rearview mirror housings and mounting brackets, and other exterior trim shall be chrome-plated, stainless steel, plastic, or anodized aluminum. Painting of the chassis parts and undercarriage shall be in accordance with the chassis manufacturer's standard practice for near identical model vehicles furnished to the general public.

5.1.9 Exterior colors. Except as specified in acquisition documents, exterior colors shall conform to table I for the appropriate military service or agency and vehicle type. Color numbers shall conform to FED-STD-595.



## MIL-STD-1223AB

TABLE I. Exterior colors.

Service or agency	Vehicle type	Color number	Color
Army	All	See 5.1.9.1	Manufacturer's standard
Army National Guard	All	See 5.1.9.1	Manufacturer's standard
Navy	All	See 5.1.9.2	Gloss white
Air Force	All	15045	Gloss blue
Marine Corps	All	See 5.1.9.2	Gloss white
Defense Logistics Agency	All	See 5.1.9.2	Gloss white
Department of Defense	Sedans and station wagons	17038	Gloss black
Department of Defense	All others	16187	Gloss gray

\* 5.1.9.1 Army and Army National Guard exterior colors. The exterior color of Army and Army National Guard vehicles shall be the widest assortment of the manufacturer's standard, gloss, light or medium colors (one color per vehicle) possible for any given destination. For trucks, the exterior color of the cab and body shall match (except for bright finished aluminum, anodized aluminum, prepainted aluminum and 2B stainless steel bodies, (see 5.1.1.2 and 5.1.1.3)).

5.1.9.2 Navy, Marine Corps and Defense Logistics Agency exterior colors. The exterior color of general service vehicles furnished the Navy, Marine Corps and Defense Logistics Agency shall be the manufacturer's standard gloss white which provides the closest match to color chip 17886. The exterior color of the cab and body shall match (except for bright finished aluminum, anodized aluminum, prepainted aluminum and 2B stainless steel bodies, see 5.1.1.2 and 5.1.1.3).

\* 5.2 Wood and plywood preservative treatment. When wood treatment is required by specifications or other acquisition documents, the following shall apply. Prior to preservative treatment, wood and plywood surfaces shall be dry and thoroughly cleaned of dirt, grease and other foreign matter. Wood and plywood parts shall contain not more than 19 percent, by weight, of moisture before and after treatment. Where practicable, wood and plywood parts shall be cut to final dimensions and boring and shaping operations shall be completed prior to treatment. All untreated exposed areas resulting from subsequent fitting of such parts shall be liberally brushed with a preservative composed of 2.5 - 5.0 percent, by weight, of solubilized copper-8-quinolinolate. The following also shall apply:



## MIL-STD-1223AB

- (a) The preservation shall be accomplished by a pressure treating process. The contractor shall be responsible for developing, testing and approving the process so as to achieve satisfactory results.
  - \* (b) Wood used on closed bodies such as ambulance, bus, van and refrigerator vans shall be pressure treated with solubilized copper-8-quinolinolate to a minimum retention of .20 pounds per cubic foot (pcf). Plywood used on such closed bodies shall be liberally brushed with a preservative composed of 2.5 - 5.0 percent, by weight, of solubilized copper-8-quinolinolate.
  - (c) Wood and plywood parts used on open and platform type bodies and on exposed wood such as stake racks and panels shall be pressure treated with chromated copper arsenate to a minimum retention of .25 pcf or with copper naphthenate to a minimum retention of .040 pcf.
  - (d) Treated wood and plywood shall present a completely paintable surface when painting is required (see 5.1, last two sentences).
- \* 5.3 Rustproofing. When rustproofing is required by specifications or other acquisition documents, the vehicle shall be rustproofed in accordance with FED-STD-297.

5.4 Identification markings for Army and Army National Guard vehicles. Side markings for Army and Army National Guard nontactical vehicles shall not be applied. Except for trailers, semitrailers and dollies, single, rear window or rear bumper markings containing the service identification "U.S. ARMY" or "ARMY NATIONAL GUARD" and the legend "FOR OFFICIAL USE ONLY" shall be applied. Front and rear license plate markings are required on all vehicles (see 5.5.1.2(a) and 5.5.1.3). The markings shall not be obscured by the truck body, spare tire, spare tire carrier, or any other accessory or part of the vehicle. The markings shall not be applied to mounted equipment on the vehicle without the prior approval of the procuring activity.

5.4.1 Rear window or bumper markings. Marking style and arrangement of the rear window or rear bumper markings shall be as shown in figures 1 and 3. When space dictates, the markings may be on a single line. The service identification, "U.S. ARMY" or "ARMY NATIONAL GUARD" shall be in letters 1 inch in height. The legend "FOR OFFICIAL USE ONLY" shall be in letters 1/2 inch in height. Space between lines shall be 1/2 inch.

5.4.2 Location of rear window or bumper markings. On Army and Army National Guard vehicles with rear windows visible from the exterior of the vehicle (passenger cars, station wagons, ambulances, some trucks, truck tractors, buses and utility vehicles) the markings shall be affixed to the interior of the rear window (adhesive faced markings), on the lower right hand side, except for vehicles with rear window electric defrosters, the markings shall be applied to the exterior of the window (adhesive on back).

## MIL-STD-1223AB

For vehicles without a rear window or when the rear window is blocked from exterior view, the markings shall be affixed (adhesive on back) to the rear bumper, in the center, or if the center is not usable, on the right hand side. Vehicles without a visible rear window and without a rear bumper shall have the markings applied anywhere on the center of the rear of the vehicle.

5.5 Identification markings, other services. The identification markings applied to vehicles within the scope of this standard, except for Army and Army National Guard vehicles (see 5.4), shall consist of the departmental or agency identification, "US NAVY," "US AIR FORCE," "US MARINE CORPS," "DEFENSE LOGISTICS AGENCY," and "DEPARTMENT OF DEFENSE," whichever is applicable; the military registration number assigned; and the legend "FOR OFFICIAL USE ONLY." Except as otherwise specified herein, markings shall be applied on both sides and on the rear of each vehicle in a location to be readily visible. The rear markings shall not be obscured by the spare tire, spare tire carrier, or any other accessory or part of the vehicle. Registration markings shall not be applied to mounted equipment on vehicles without the prior approval of the procuring activity. Marking style, size, and spacing shall be as shown in figures 1, 2 and 3. The several elements of the registration markings shall be arranged on both sides and the rear as follows:

- a. Side markings shall consist of the departmental or agency identification on the top line (top two lines for Department of Defense), the military registration number on the next line, and the legend on the bottom line. Each line shall have a common centerline to provide the arrangement illustrated in figures 3 through 9. When space does not permit "DEPARTMENT OF DEFENSE" to be applied on two lines, one line may be used as shown in figure 10.
- b. Rear markings shall consist of the departmental or agency identification and the military registration number. The legend shall not be included at the rear of the vehicle.

5.5.1 Marking locations. Markings shall be located as specified herein; however, where obstructions exist, or where configuration of body or cab interferes with legibility, the markings shall be relocated with the approval of the procuring activity.

5.5.1.1 Sides of vehicles.

- a. Passenger car, station wagon, ambulance, truck, truck chassis and truck tractor markings shall be centered on each front door or in a comparable position in relation to the driver's seat on vehicles with sliding doors or without doors (see figures 12 through 17).
- b. Bus markings shall be applied on the panels, just below the windows, to the rear of the entrance door on one side, and to the rear of the driver's compartment on the other side (see figure 19).
- c. Trailer and semitrailer markings shall be centered vertically on each side of the front quarter of the vehicle (see figures 21 and 22).

## MIL-STD-1223AB

- d. Semitrailer converter dolly markings shall be applied on each side, on the most appropriate surface consistent with good visibility.
- e. Solo motorcycle marking shall be located on both sides of the fuel tank. Markings on motorcycles with sidecars shall be centered vertically on the door or outside panel of the vehicle.
- f. Motor scooter markings shall be located on both sides of the package compartment or other appropriate surface.

5.5.1.2 Rear of vehicle.

- a. Army, Army National Guard and Defense Logistics Agency. Marking on the rear of Army, Army National Guard, and Defense Logistics Agency vehicles shall be accomplished by use of a plate bolted to the rear license plate bracket. The identification plate and bracket shall be furnished by the manufacturer. The department or agency identification "U S Army", "ARNG", "DLA", as applicable, and the military registration number shall be applied as shown in figure 4. Typical Army and DLA rear markings are shown in figures 11, 16, 18, 20 and 23. The plate shall conform to one of the following:
  - (1) A .060-.075 inch thick aluminum plate 6 inches in height, 12 inches in width. The marking background material covering the front of the plate shall conform to type I, class 1, 2 or 3, reflectivity 1 white of L-S-300.
  - (2) A .027-.032 inch thick aluminum embossed plate 6 inches in height, 12 inches in width. The face of the license plate shall be fully treated with a reflectorized coating that shall provide a minimum reflective brightness of five candlepower per foot candle per license plate for a period of five years. The reflectorized coating shall function as an effective and dependable safety warning device and shall improve the legibility of the license plate for law enforcement purposes.
- b. Air Force, Navy and Marine Corps. The departmental or agency identification and military registration number shall be arranged on one line in such location as to be readily identifiable from the rear.
- c. Department of Defense. The departmental identification and military registration number shall be arranged on three lines in such a location as to be readily identifiable from the rear. When space does not permit rear markings to be applied on three lines, one or two lines may be used.
- d. Motorcycles, scooters and snowmobiles. Plates furnished on motorcycles, scooters and snowmobiles may be reduced in size as appropriate to conform to the normal practice for license plates for these types of vehicles.

## MIL-STD-1223AB

5.5.1.3 Front of vehicle. For Army, Army National Guard, and Defense Logistics Agency self-propelled vehicles, the markings and plate specified in 5.4.1.2.a for the rear of the vehicle shall also be furnished on the front of the vehicle. The plate shall be bolted to the front license plate bracket or bumper recess.

5.5.2 Marking material. Except as otherwise specified herein, markings shall be applied using die cut, previously spaced, individual letters and numbers applied directly to the vehicle. Reflectorized marking shall be applied using reflectorized tape conforming to type I, class 1 or 3, reflectivity 1 of L-S-300 for all colors except black. Reflectorized black color shall be applied using reflectorized tape meeting the performance requirements of type I, class 1 or 3, reflectivity 1 of L-S-300 and possessing a minimum reflectivity of 10 candle power per foot-candle per square foot at 0.2-degree divergence and minus 4-degree incidence angles. Nonreflectorized marking shall be applied using material conforming to types I or II, class 1 of MIL-M-43719.

\* 5.5.2.1 Removable markings. Markings shall be removable, using the marking manufacturer's recommendations, from vertical painted surfaces without the aid of chemicals or solvents for up to 4 years with no damage to the painted surfaces and with little or no adhesive residue.

5.5.3 Marking colors. Colors of markings shall be as specified herein for the appropriate military service or agency, background color and vehicle type. Reflective colors shall be as classified in L-S-300. Painted and elastomeric material colors shall conform to FRD-STD-595.

5.5.3.1 Army and Army National Guard marking colors. The manufacturer's standard gloss white shall be used on the rear window markings. Gloss white markings shall be used on chrome and dark colored bumpers. Gloss black No. 17038 markings shall be used on light colored bumpers. Borderline decisions between white on dark bumpers and black on light bumpers shall be the contractor's with white generally preferred. Gloss black color No. 17038 numerals and letters on a reflective white background shall be used on the front and rear marking plates.

5.5.3.2 Navy marking colors.

- a. Reflective blue markings shall be used on vehicles painted gloss white.
- b. Reflective black markings shall be used on vehicles painted gloss yellow, gloss green and gloss red.
- c. Reflective white markings shall be used on vehicles painted gloss black and gloss blue.

## MIL-STD-1223AB

5.5.3.3 Air Force marking colors.

- a. Reflective yellow numerals and letters shall be used on vehicles painted blue.
- b. Reflective black numerals and letters shall be used on ambulances painted white. Reflective yellow numerals and letters on a blue background shall be used on all other vehicles painted white.
- c. Reflective white numerals and letters on a red background shall be used on vehicles painted red or yellow.
- d. Lusterless black, color No. 37038, markings shall be used on vehicles painted semigloss green, color No. 24052.
- e. Lusterless white, color No. 37875, markings shall be used on vehicles painted desert sand.

5.5.3.4 Marine Corps marking colors.

- a. Reflective black markings shall be used on vehicles painted gloss white or gloss yellow.
- b. Reflective yellow markings shall be used on vehicles painted standard Marine Corps gloss green or gloss red.
- c. Reflective gold markings shall be used on special purpose vehicles when authorized by Marine Corps directive.

5.5.3.5 Defense Logistics Agency marking colors. Marking color(s) for the applicable vehicle exterior color for the Defense Logistics Agency shall be the same as specified in 5.5.3.2 for the Navy.

5.5.3.6 Department of Defense marking colors. Marking color(s) for the applicable vehicle exterior color for the Department of Defense shall be the same as specified in 5.5.3.1 for the Army and Army National Guard.

5.6 Data plates. A nameplate, a parts data plate or label, and instruction plates shall be installed on each vehicle.

5.6.1 Nameplate. The information required for the nameplate shall be inscribed or stamped in such a manner that the legend will be discernable if inadvertently painted over. Metal plates shall be of non-ferrous material. Plastic or non-metallic plates shall be approximately 1/32-inch thick. The nameplate shall include at least the information shown in a or b below, except: (1) Gross combination weight rating is required only on truck tractors (2) Vehicle curb weight, payload and gross weight rating are not required on sedans and station wagons; and (3) Vehicle curb weight is not required on trucks of 10,000 pounds gross vehicle weight or less.

## MIL-STD-1223AB

## a. All vehicles, except cab and chassis models:

Nomenclature: (as applicable to the type of vehicle specified in the contract. )

Make and model:

Manufacturer's serial number:

Registration number:

NSN Number:

Vehicle curb weight: \_\_\_\_\_ pounds.

Payload, maximum: \_\_\_\_\_ pounds.

Gross vehicle weight rating, max. \_\_\_\_\_ pounds.

Gross combination weight rating, max. \_\_\_\_\_ pounds.

1/ Date of delivery: (month and year)

Warranty: \_\_\_\_\_ mo. \_\_\_\_\_ miles.

Contract number:

US Property

## b. Cab and chassis models only:

Make and model:

Manufacturer's serial number:

Registration No. :

Gross vehicle weight rating, max: \_\_\_\_\_ pounds.

1/ Date of delivery: (month and year)

Warranty: \_\_\_\_\_ mo. \_\_\_\_\_ miles.

Contract number:

1/ (Date of delivery shall be left blank until the vehicle is accepted by the Government inspector. Date of delivery shall be not prior to date of acceptance indicated on form DD 250.)

5.6.2 Parts data plate or label. The manufacturer's standard parts data plate or label shall be provided and mounted at the driver's compartment or under the hood of all trucks, truck ambulances, and buses. Labels shall be laminated or of such composition as to prevent deterioration. The data plate or label shall list the applicable vehicle model number and the manufacturer's part code number for at least the clutch, transmission, transfer case, front and rear axles, and the differentials for front, rear, and intermediate axles. The plate or label shall include information required for any of the manufacturer's warehouse or dealer service points to identify and provide the required service parts.

\* 5.6.3 Data plate mounting. Instruction plates pertaining to mounted equipment shall be mounted adjacent to the equipment controls. Plates inscribed with the shifting pattern, for vehicles having more than 3 forward speeds, shall be mounted in a location clearly visible to the driver. The manufacturer's instruction plate is acceptable and may be incorporated in the gear shift lever knob at the manufacturer's option. Unless concealed or



## MIL-STD-1223AB

temporary markings are specified, nameplates shall be mounted on or adjacent to the vehicle instrument panel in a position that does not conflict with the glare limitations of Federal Motor Vehicle Safety Standard No. 107, in the engine compartment in a readable location or on the front right corner of the trailer, as applicable. When concealed markings are specified for self-propelled vehicles, the nameplate shall be mounted on the underside of the rear trunk lid, or if not so equipped, on another concealed but readily accessible interior surface, such as the inside of the map compartment lid or the underside of the hood. The nameplate shall be mounted on metallic surfaces using glue, self-adhesive, screws, rivets, etc. or on non-metallic surfaces using only screws, rivets or other mechanical devices.

## \* 6. NOTES

\* 6.1 Intended use. This standard provides minimum requirements for the treatment, painting, identification markings and data plates for nontactical wheeled vehicles procured by all Departments and Agencies of the Department of Defense.

\* 6.2 Issue of DODISS. When this standard is used in acquisition, the applicable issue of the DODISS must be cited in the solicitation (see 2.1.1 and 2.2).

\* 6.3 Subject term (key word) listing.

Colors  
Data plate  
Marking  
Painting  
Preservation  
Rustproofing  
Wood treatment.

\* 6.4 Changes from previous issue. The margins of this standard are marked with asterisks (\*) to indicate where changes (additions, modifications, corrections, deletions) from the previous issue were made. This was done as a convenience only and the Government assumes no liability whatsoever for any inaccuracies in these notations. Bidders and contractors are cautioned to evaluate the requirements of this document based on the entire content irrespective of the marginal notations and relationship to the last previous issue.

## Custodians:

Army - AT  
Navy - YD  
Air Force - 99

## Review activities:

Navy - MC  
Air Force - 84

## Preparing activity:

Army - AT

Project No. 23GP-0016

MIL-STD-1223AB

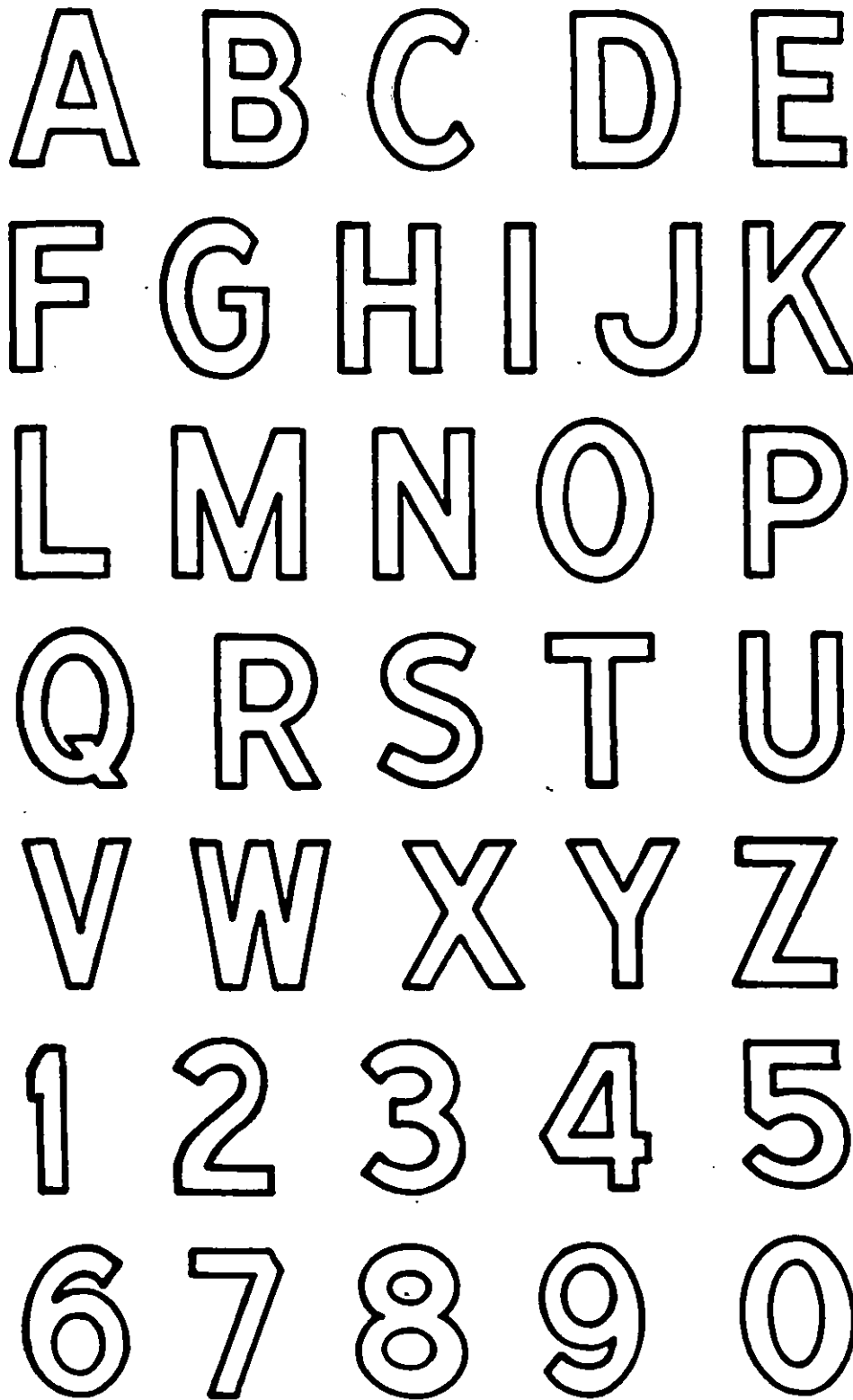
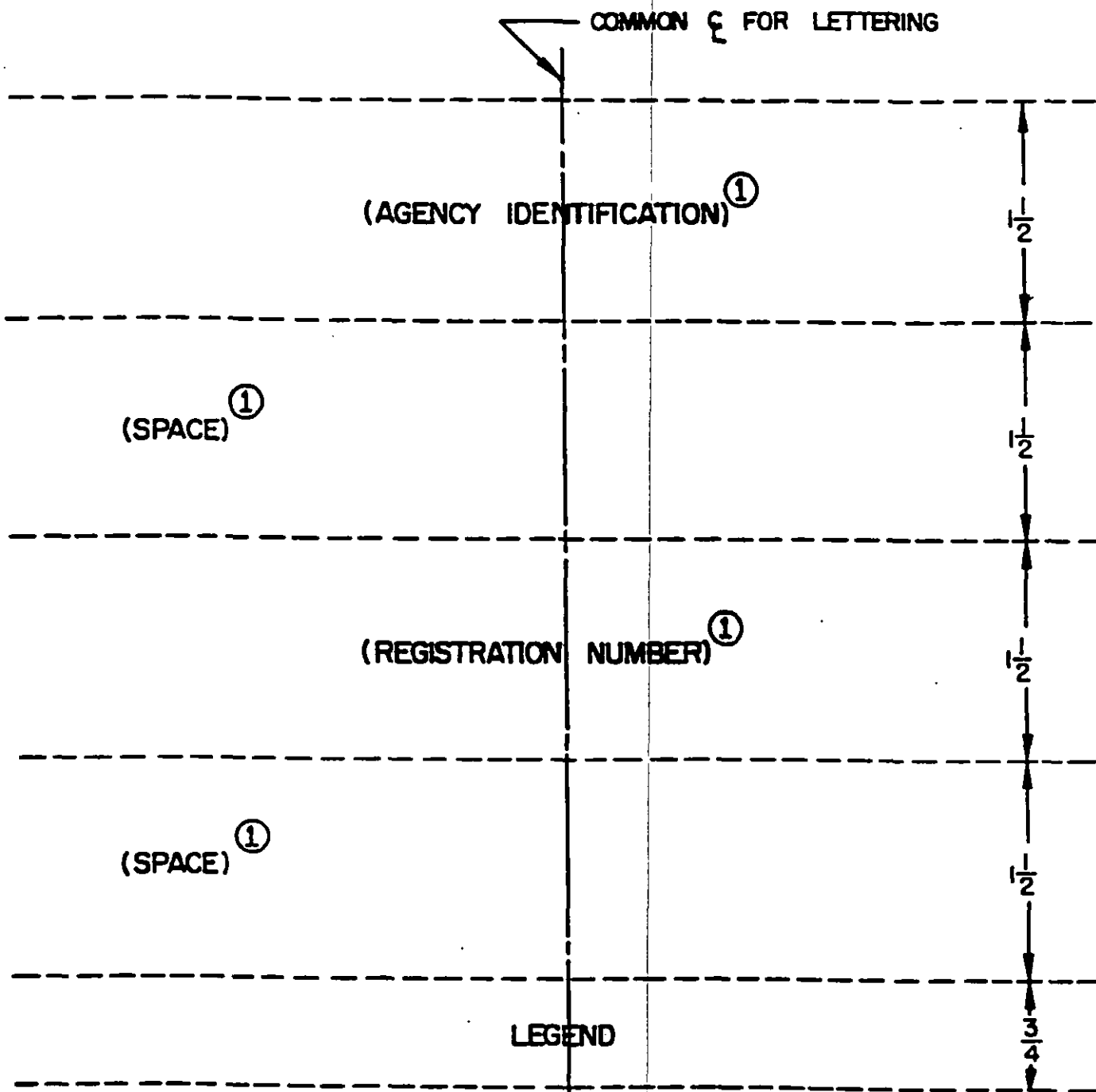

FIGURE 1. Style of vehicle marking letters.



MIL-STD-1223AB



① For motorcycles, motor scooters and snowmobiles, the size and spacing shall be 1 inch.

FIGURE 2. Size and spacing of nontactical vehicle side markings.

MIL-STD-1223AB

U S ARMY  
FOR OFFICIAL USE ONLY

FIGURE 3. Arrangement of Army markings on rear window or rear bumper.

MIL-STD-1223AB

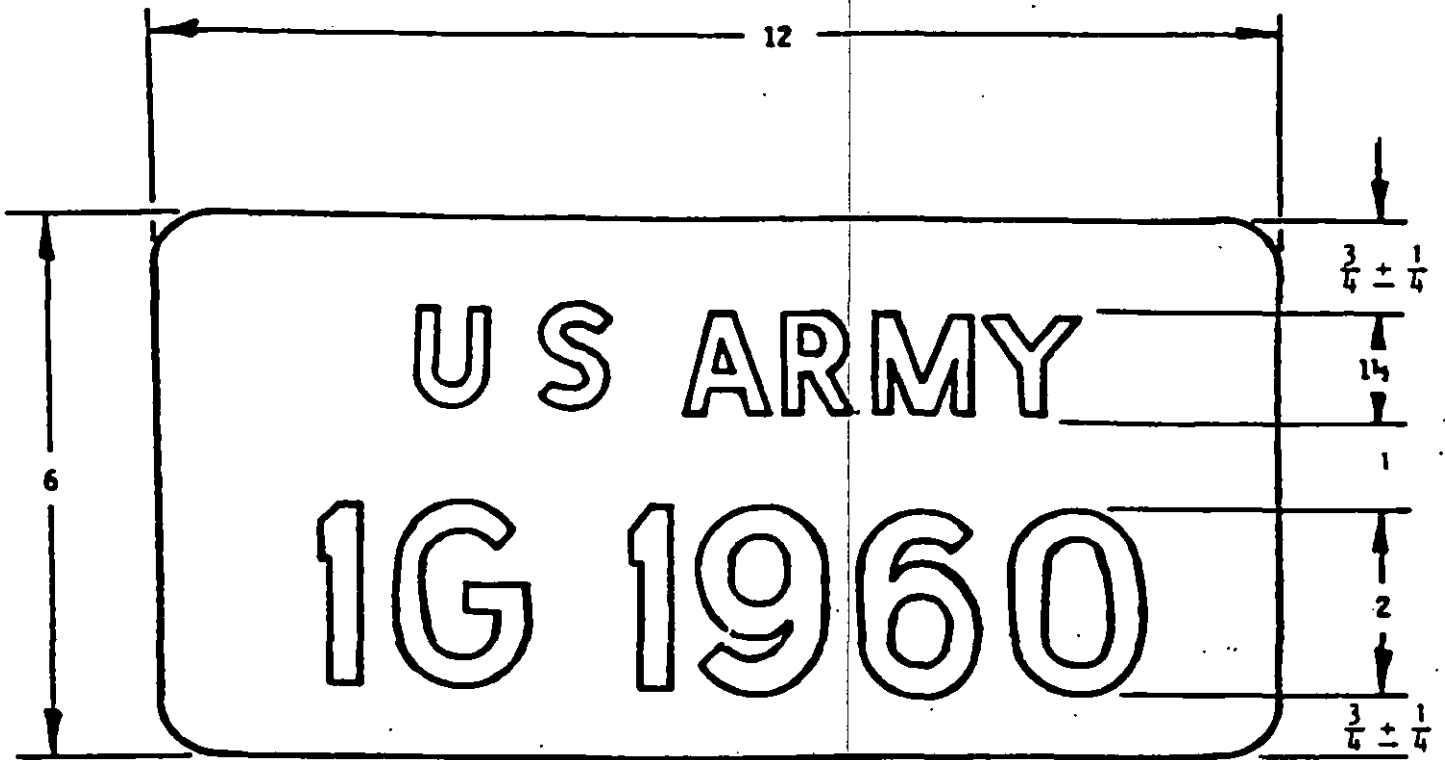

FIGURE 4. Arrangement of Army marking on front and rear plates.

MIL-STD-1223AB

U S NAVY

93-21960

FOR OFFICIAL USE ONLY

FIGURE 5. Arrangement of Navy side marking.

MIL-STD-1223AB

U S AIR FORCE  
54B 1960  
FOR OFFICIAL USE ONLY

FIGURE 6. Arrangement of Air Force side marking.

MIL-STD-1223AB

U S MARINE CORPS

234568

FOR OFFICIAL USE ONLY

FIGURE 7. Arrangement of Marine Corps side marking.

MIL-STD-1223AB

DEFENSE LOGISTICS AGENCY

63124

FOR OFFICIAL USE ONLY

FIGURE 8. Arrangement of Defense Logistic Agency side marking.

MIL-STD-1223AB

DEPARTMENT  
OF DEFENSE  
1G 1960  
FOR OFFICIAL USE ONLY

FIGURE 9. Arrangement of Department of Defense side marking.



MIL-STD-1223AB

**DEPARTMENT OF DEFENSE**  
**16 1960**

**FOR OFFICIAL USE ONLY**

**FIGURE 10. Alternate arrangement of Department of Defense side marking.**

MIL-STD-1223AB

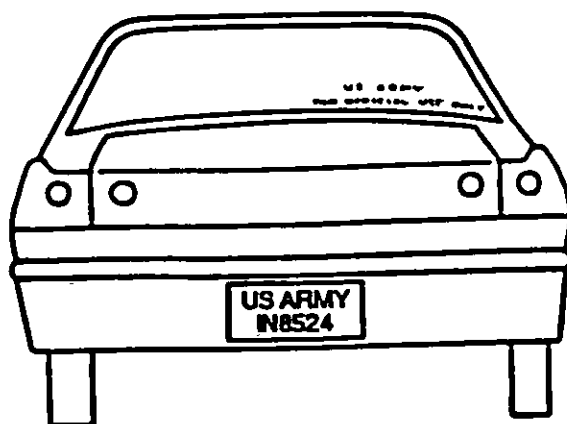
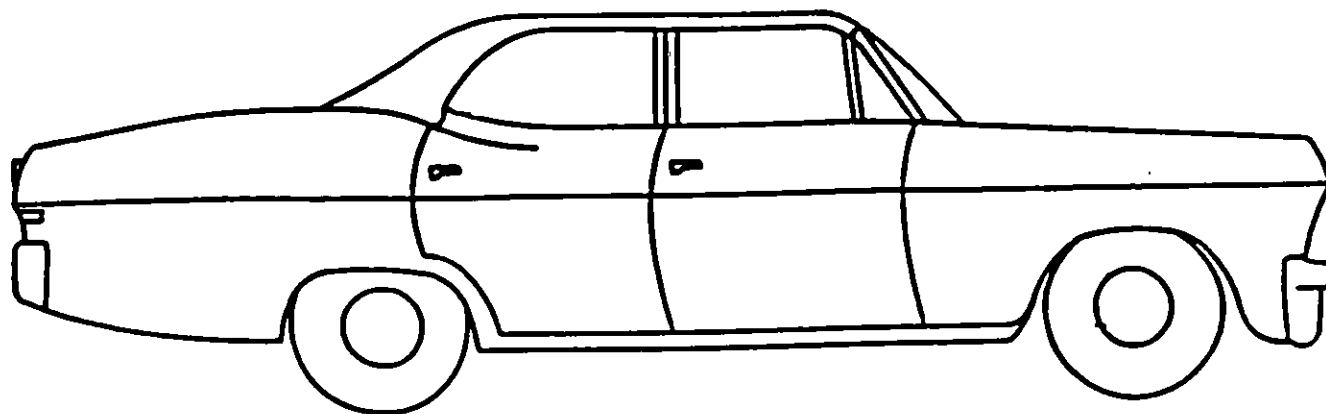

FIGURE 11. Sedan with Army markings.

MIL-STD-1223AB

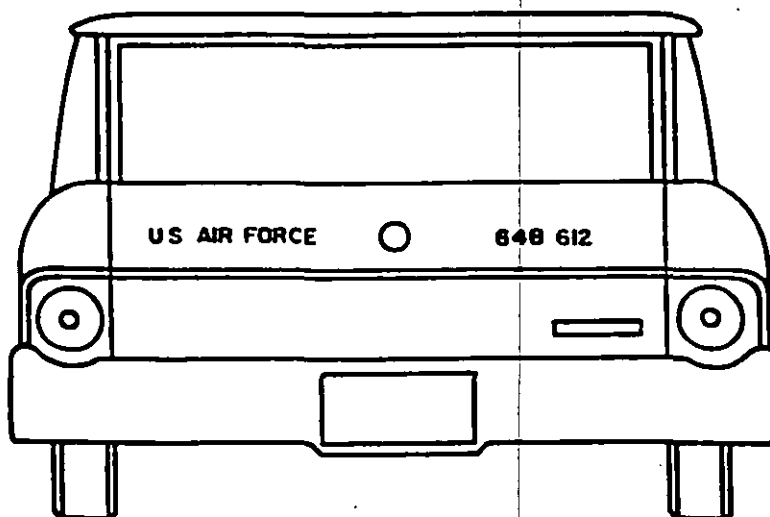
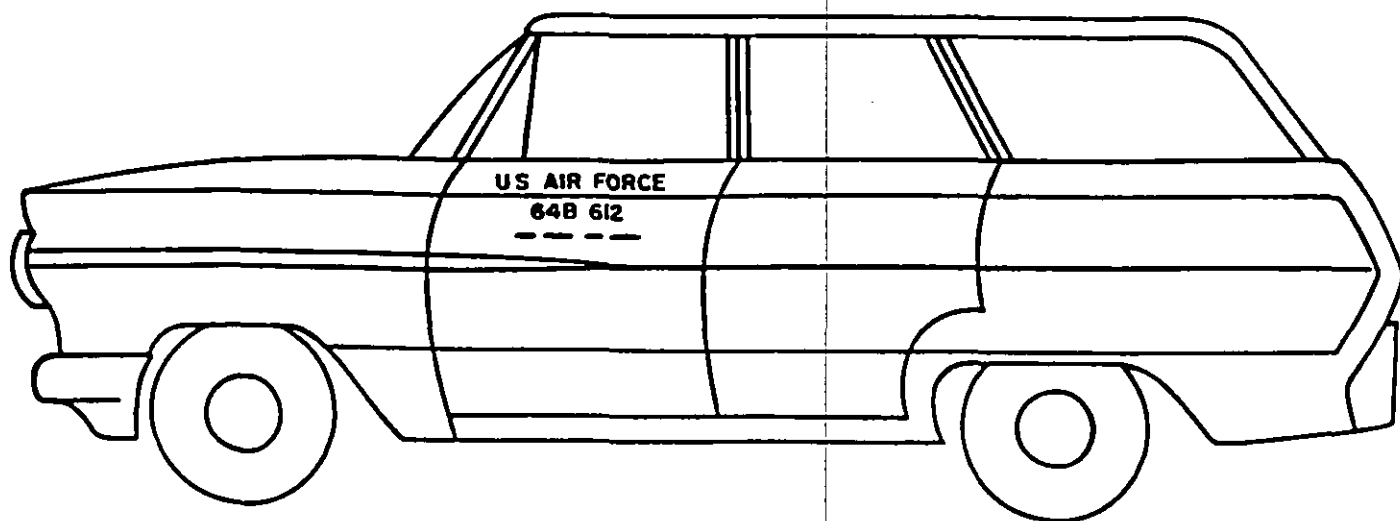

FIGURE 12. Station wagon with Air Force markings.

MIL-STD-1223AB

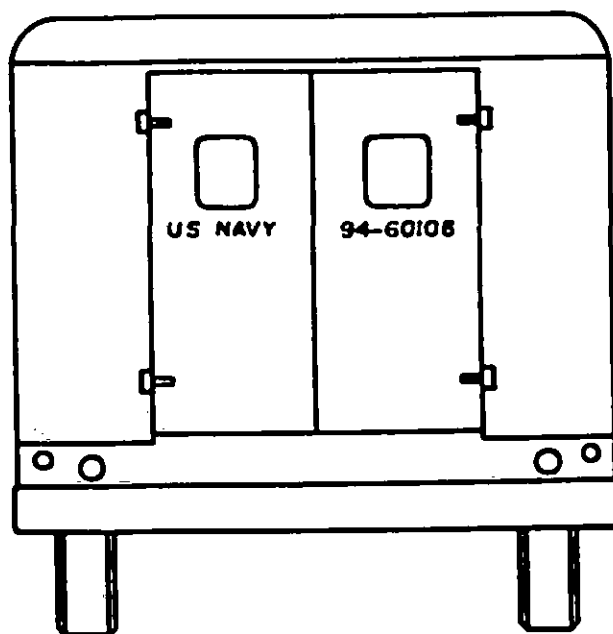
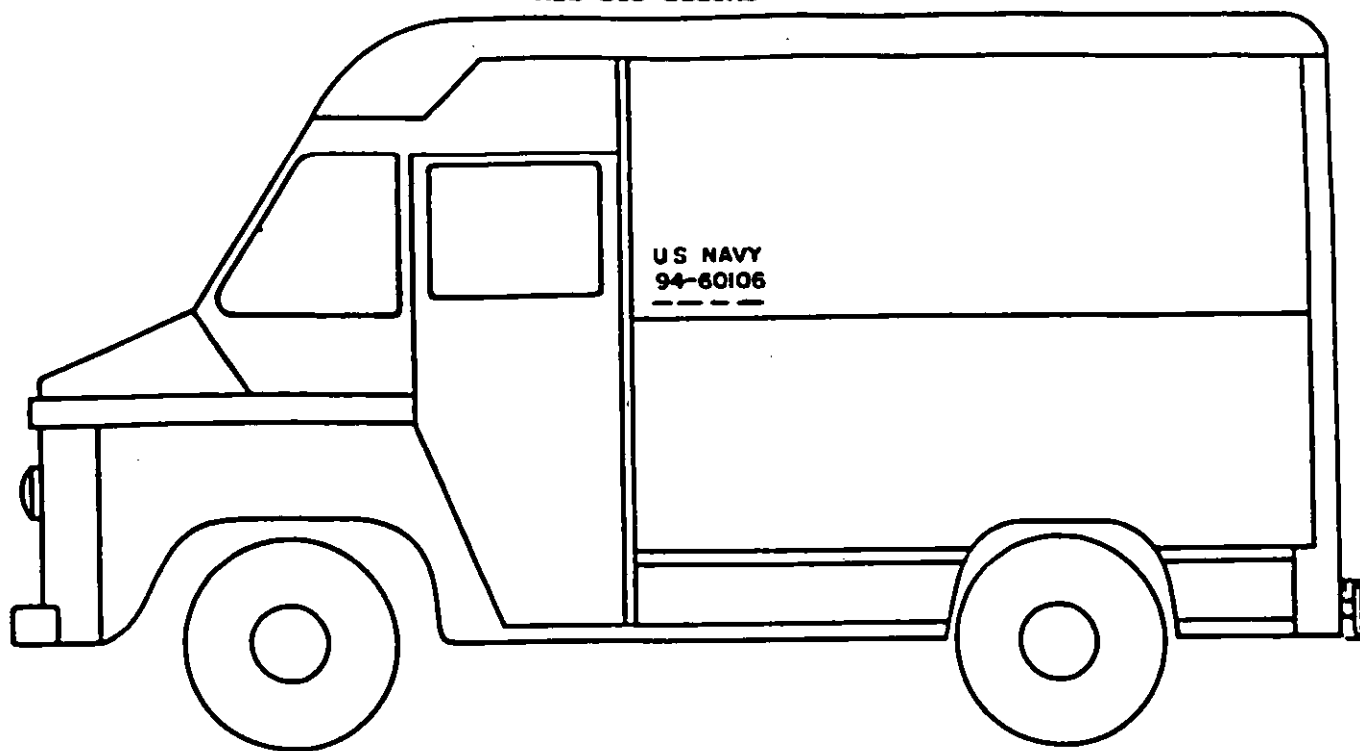

FIGURE 13. Multi-stop delivery truck with Navy markings.

MIL-STD-1223AB

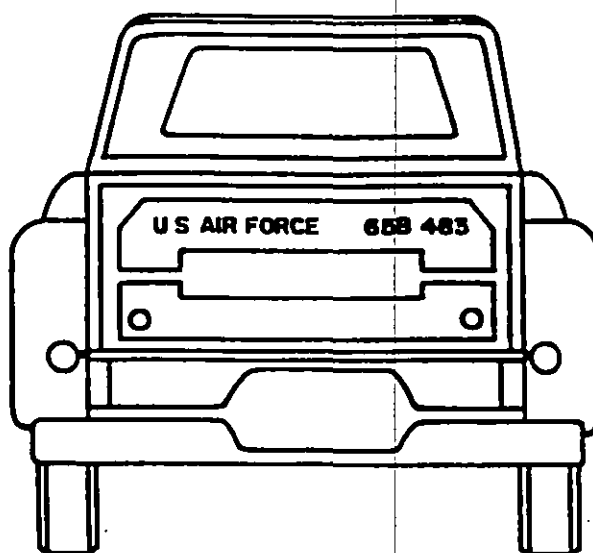
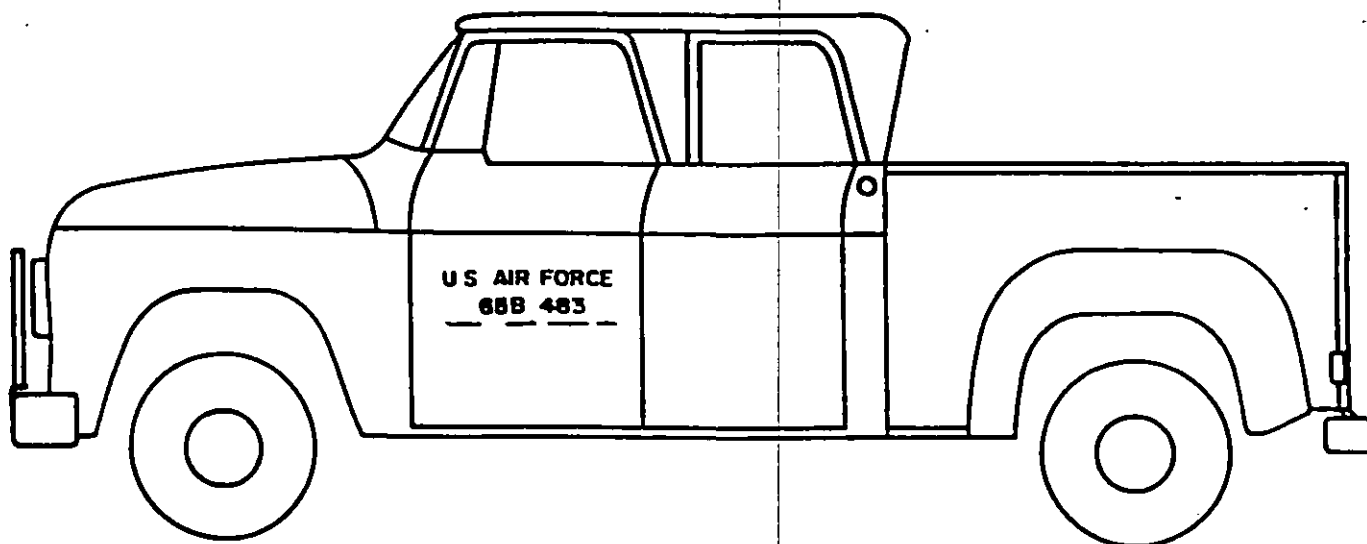

FIGURE 14: Four door cab pickup truck with Air Force markings.

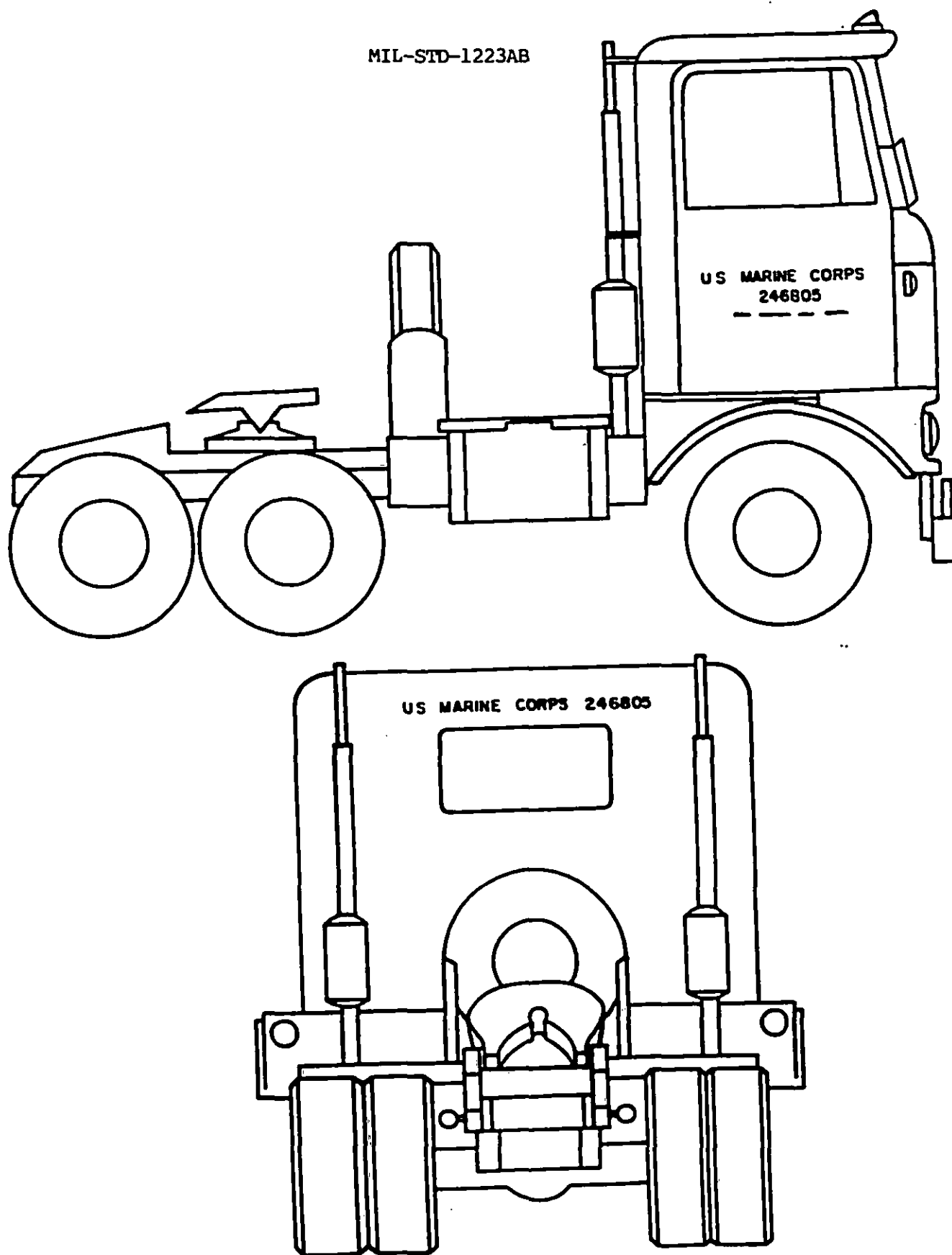

FIGURE 15. Truck Tractor with Marine Corps markings.

MIL-STD-1223AB

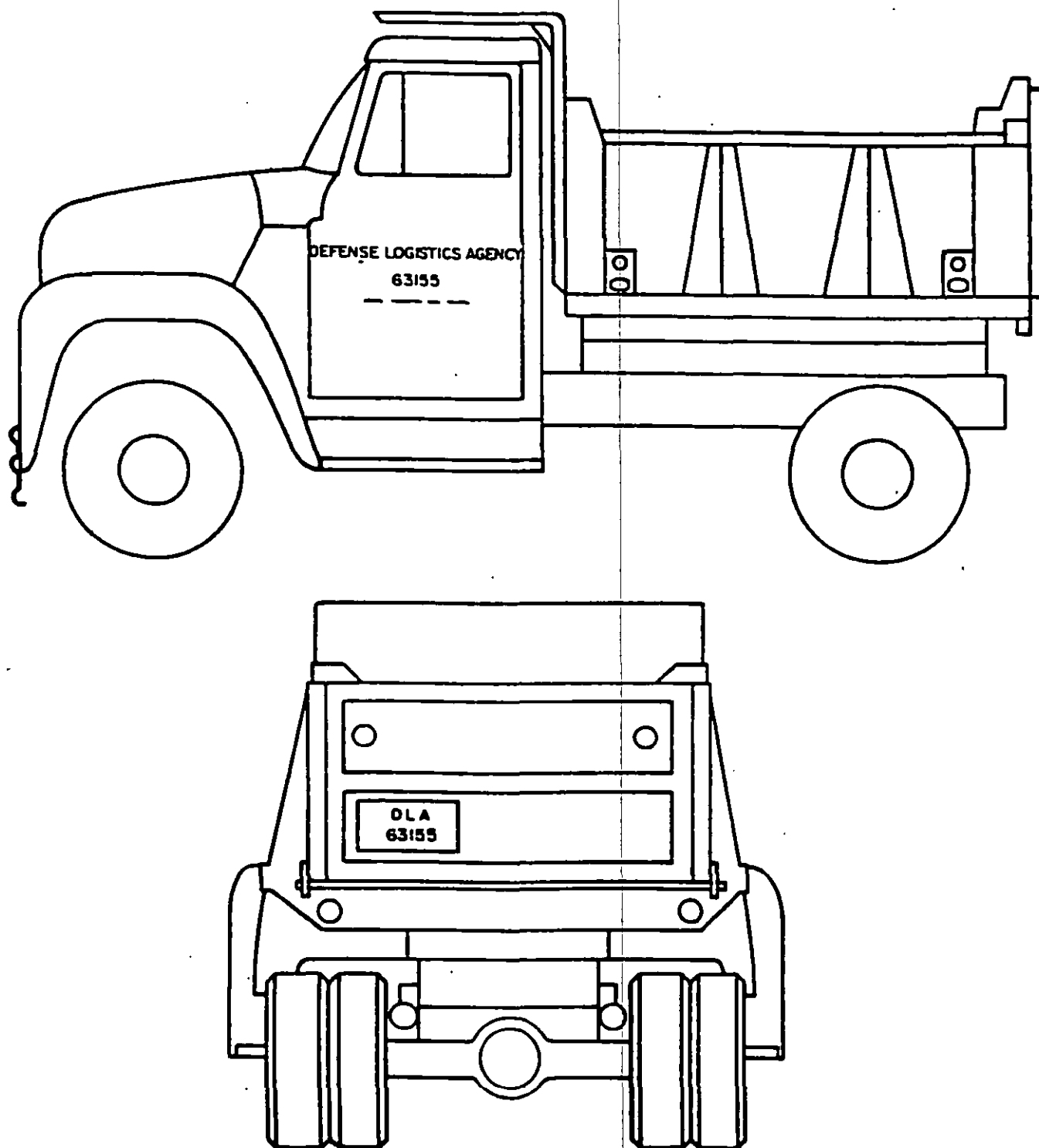

FIGURE 16. Dump truck with Defense Logistics Agency markings.

MIL-STD-1223AB

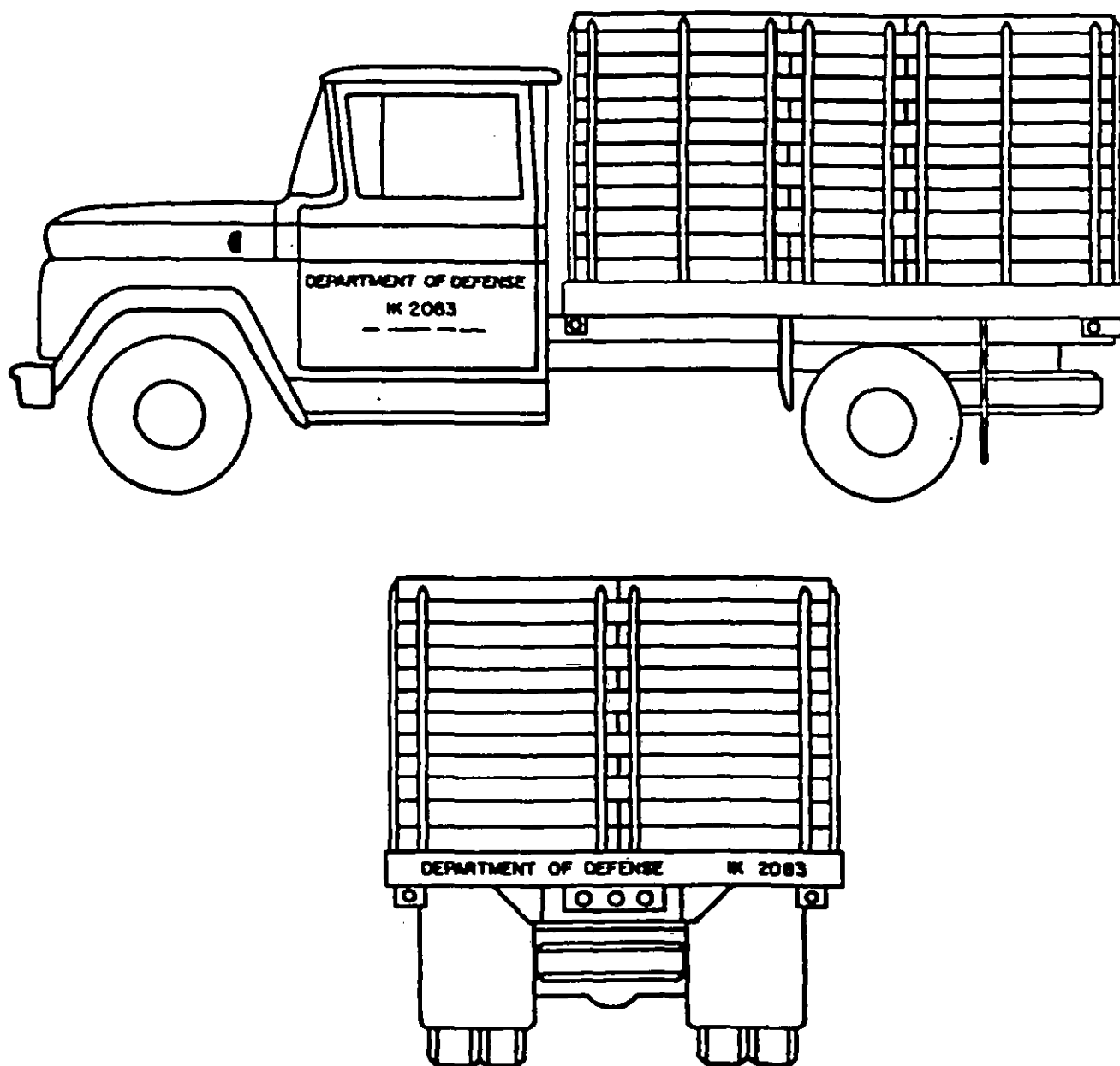

FIGURE 17. Stake and Platform truck with Department of Defense markings.



MIL-STD-1223AB

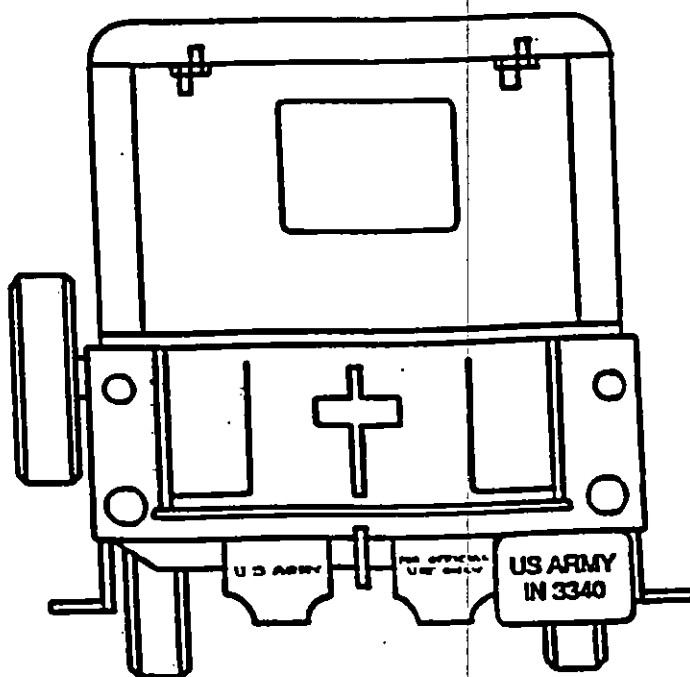
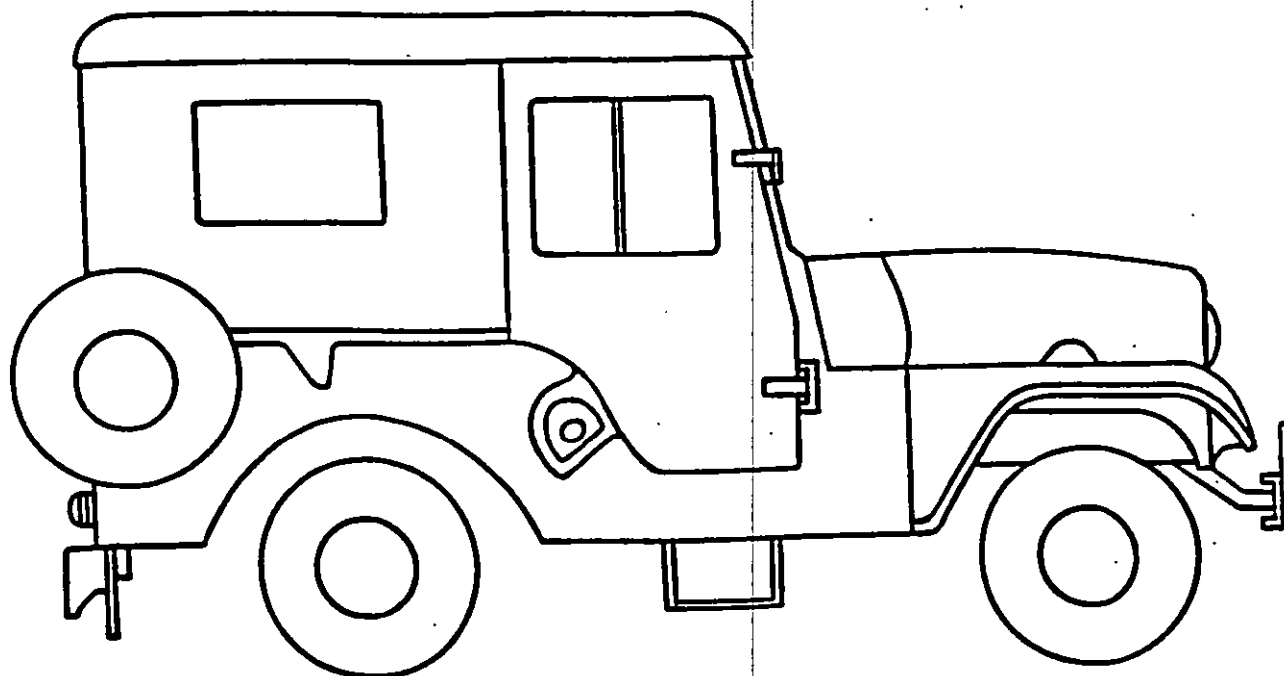

FIGURE 18. Utility truck with Army markings.

MIL-STD-1223AB

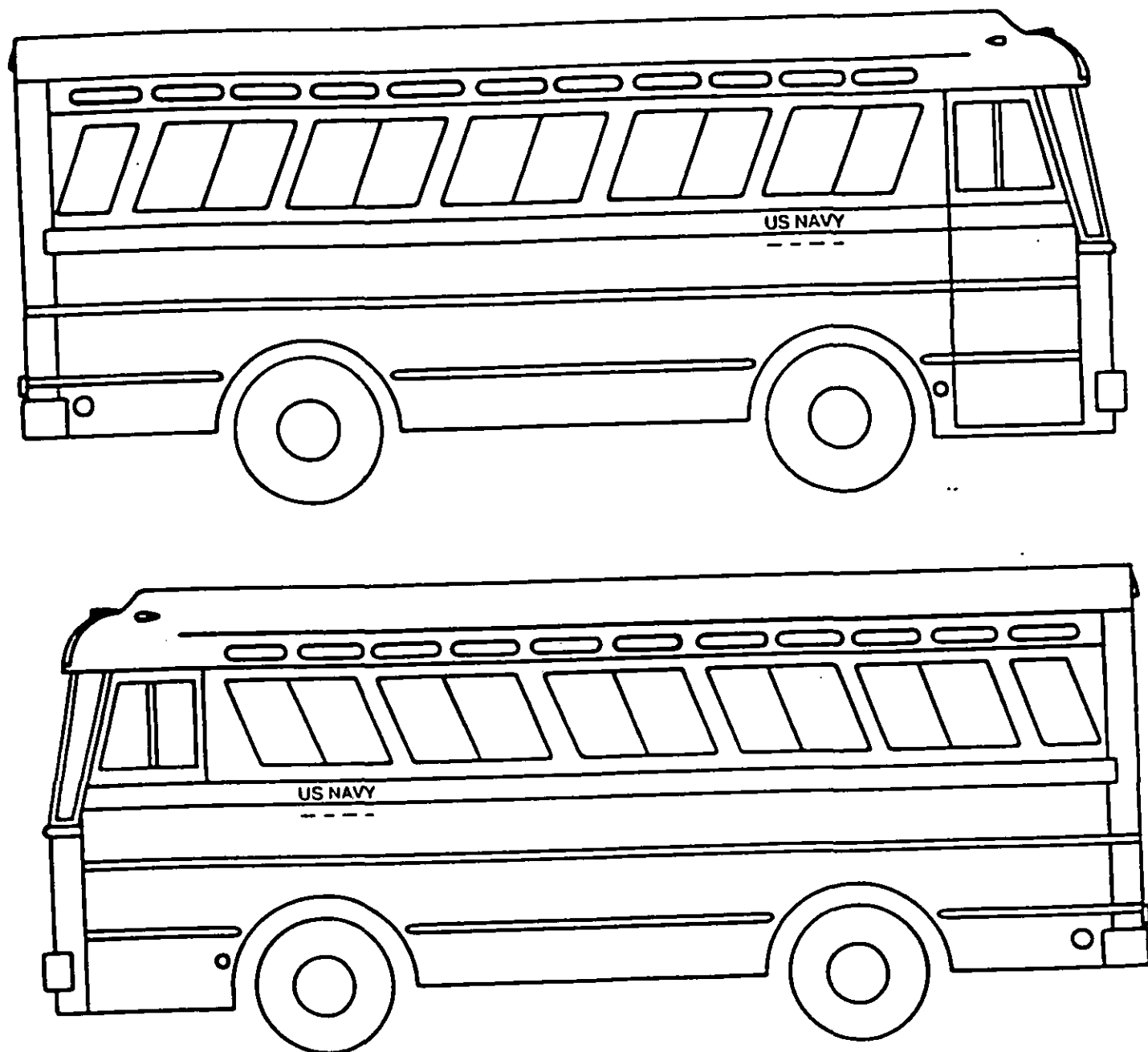

FIGURE 19. Bus with Navy markings.

MIL-STD-1223AB

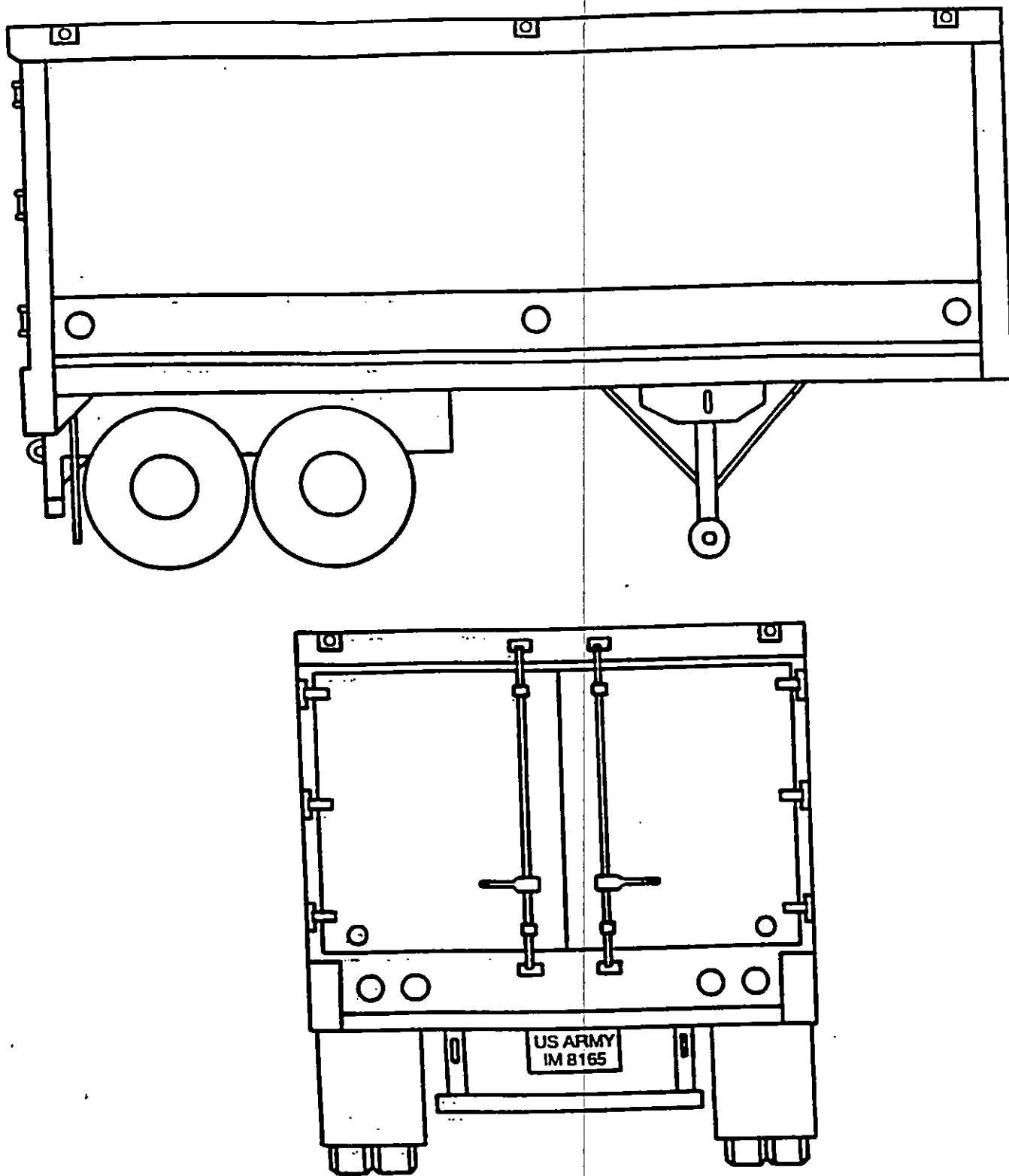

FIGURE 20. Van type semitrailer with Army markings.

MIL-STD-1223AB

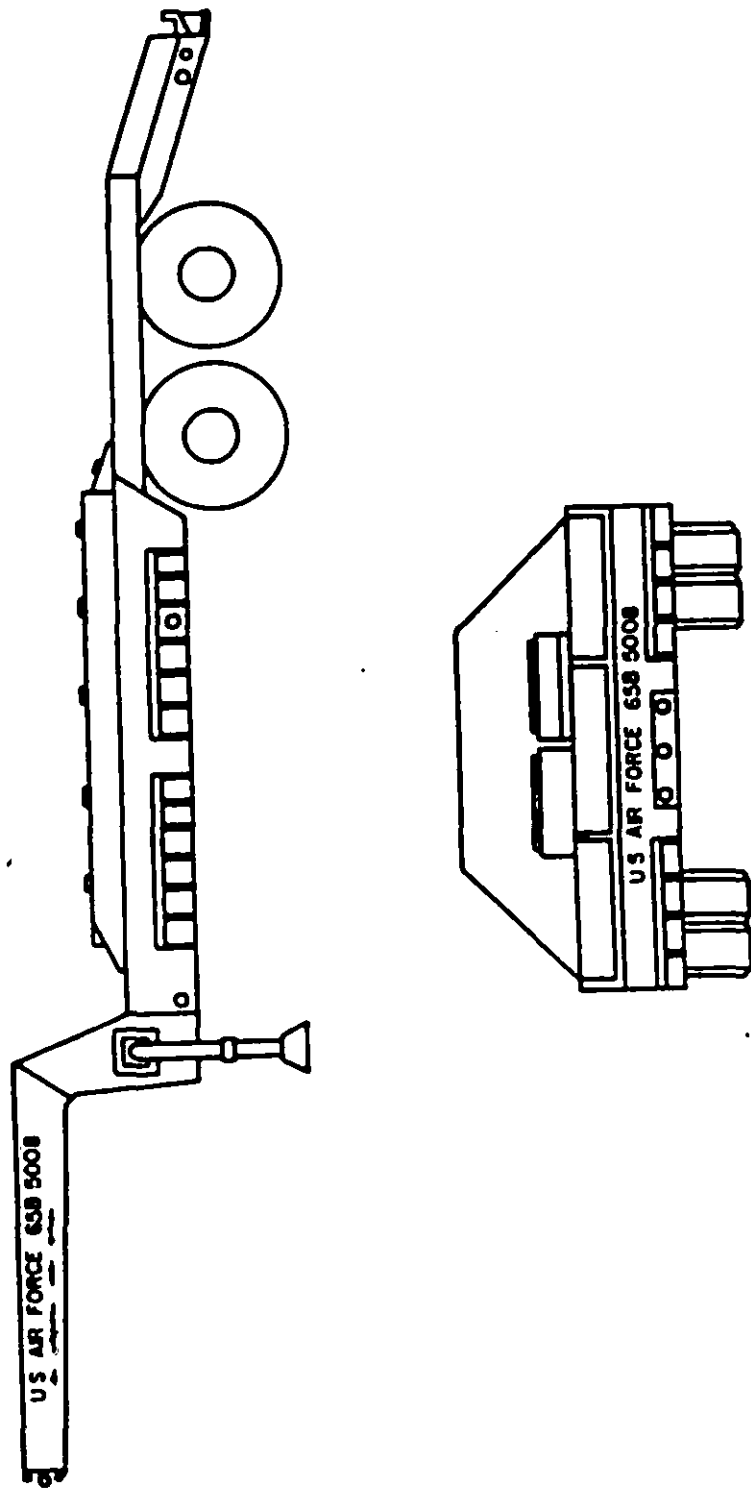

FIGURE 21. Lowbed semitrailer with Air Force markings.

MIL-STD-1223AB

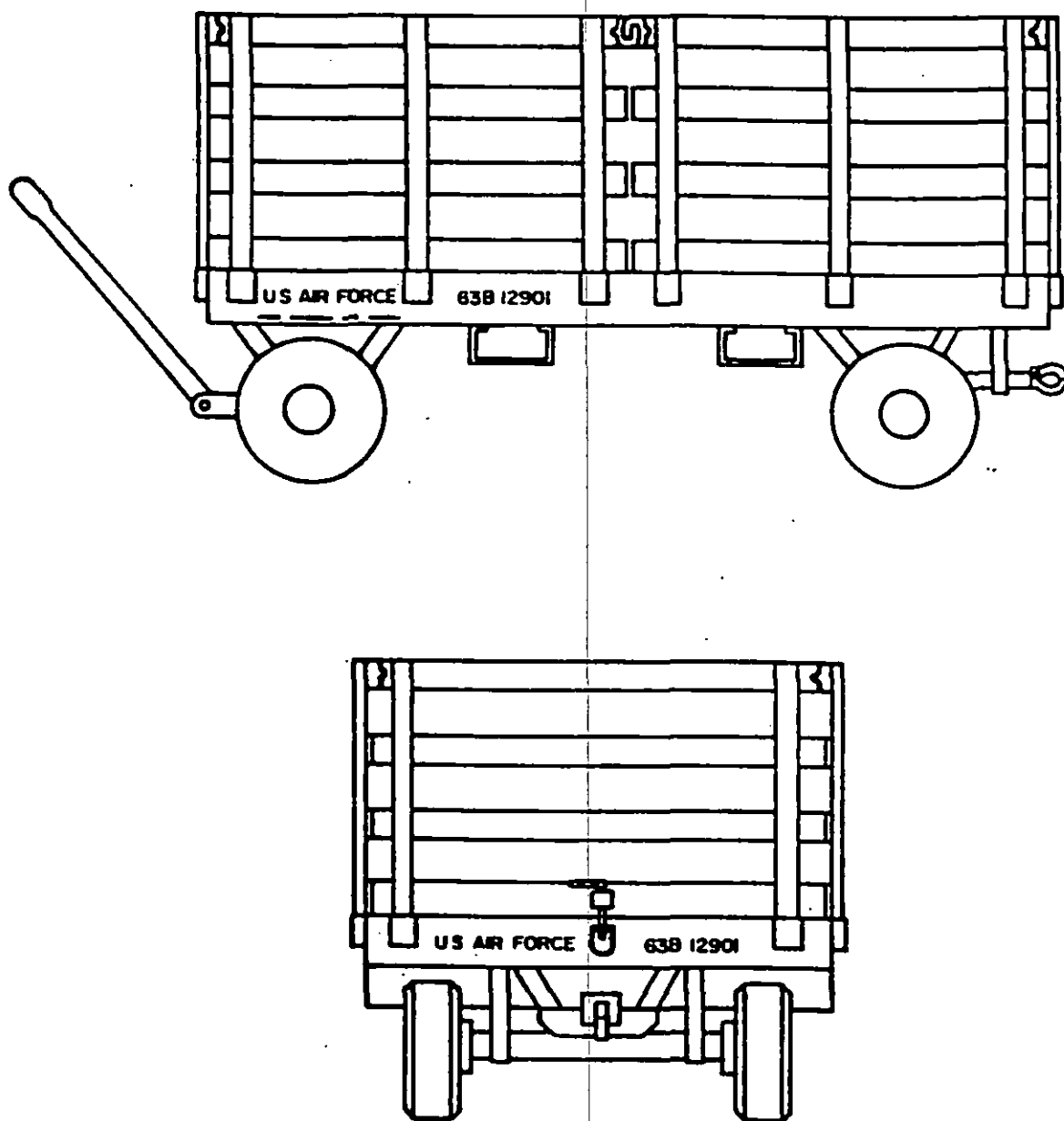

FIGURE 22. Four wheel stake trailer with Air Force markings.

MIL-STD-1223AB

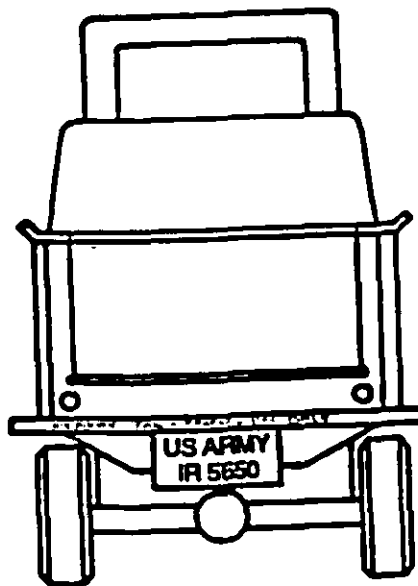
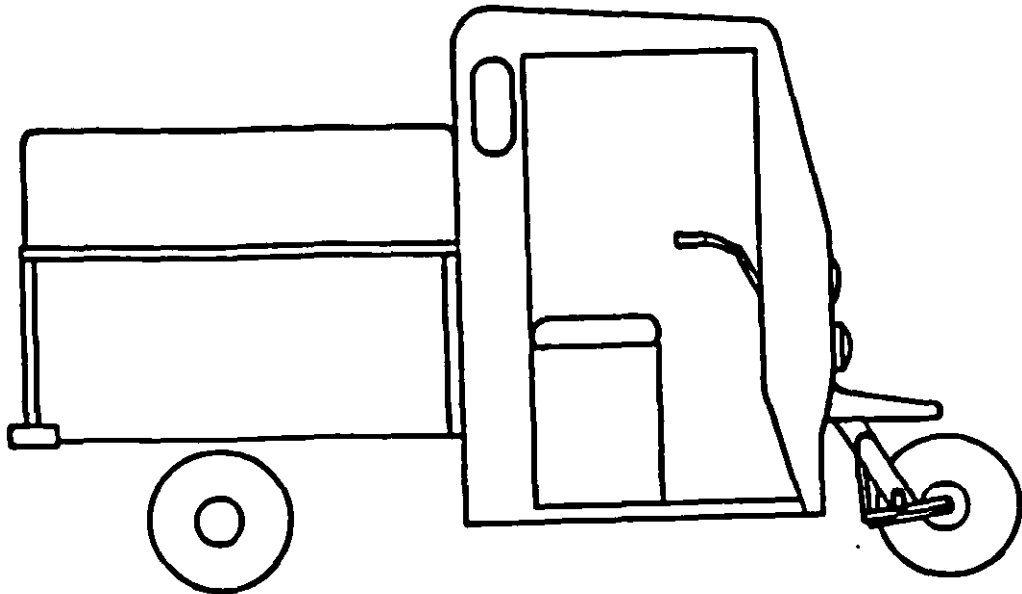

FIGURE 23. Scooter with Army markings.

FOLD

---

POSTAGE AND FEES PAID



**OFFICIAL BUSINESS**  
**PENALTY FOR PRIVATE USE \$300**

Commander  
U.S. Army Tank-Automotive Command  
ATTN: AMSTA-UED  
Warren, Michigan 48397-5000

---

FOLD

STANDARDIZATION DOCUMENT IMPROVEMENT PROPOSAL	
<p><b>INSTRUCTIONS:</b> This form is provided to solicit beneficial comments which may improve this document and enhance its use. DoD contractors, government activities, manufacturers, vendors, or other prospective users of the document are invited to submit comments to the government. Fold on lines on reverse side, staple in corner, and send to preparing activity. Attach any pertinent data which may be of use in improving this document. If there are additional papers, attach to form and place both in an envelope addressed to preparing activity. A response will be provided to the submitter, when name and address is provided, within 30 days indicating that the 1426 was received and when any appropriate action on it will be completed.</p> <p><b>NOTE:</b> This form shall not be used to submit requests for waivers, deviations or clarification of specification requirements on current contracts. Comments submitted on this form do not constitute or imply authorization to waive any portion of the referenced document(s) or to amend contractual requirements.</p>	
<p><b>DOCUMENT IDENTIFIER (Number) AND TITLE</b> MIL-STD-1223AB NONPRACTICAL WHEELED VEHICLES TREATMENT, PAINTING, IDENTIFICATION MARKING AND DATA PLATE STANDARDS</p>	
<p><b>NAME OF ORGANIZATION AND ADDRESS OF SUBMITTER</b></p> <p><input type="checkbox"/> VENDOR      <input type="checkbox"/> USER      <input type="checkbox"/> MANUFACTURER</p>	
<p>1. <input type="checkbox"/> HAS ANY PART OF THE DOCUMENT CREATED PROBLEMS OR REQUIRED INTERPRETATION IN PROCUREMENT USE? <input type="checkbox"/> IS ANY PART OF IT TOO RIGID, RESTRICTIVE, LOOSE OR AMBIGUOUS? PLEASE EXPLAIN BELOW.</p> <p><b>A. GIVE PARAGRAPH NUMBER AND WORDING</b></p> <p><b>B. RECOMMENDED WORDING CHANGE</b></p> <p><b>C. REASON FOR RECOMMENDED CHANGE(S)</b></p>	
<p>2. REMARKS</p>	
<p>SUBMITTED BY (Printed or typed name and address - Optional)</p>	<p>TELEPHONE NO.</p> <p>DATE</p>

DD FORM 1426  
1 OCT 78

EDITION OF 1 JAN 72 WILL BE USED UNTIL EXHAUSTED.