

**NOT MEASUREMENT  
SENSITIVE**

**ML-STD-1191**

**31 DECEMBER 1989**

**SUPERSEDING**

**ML-F-45216A**

**15 JULY 1984**

**MILITARY STANDARD  
FOAM-IN-PLACE PACKAGING  
PROCEDURES FOR**



**AMDC N/A**

**AREA PACK**

**DISTRIBUTION STATEMENT A. Approved for public release;  
distribution is unlimited**

MIL-STD-1191

FOREWORD

1. This military standard is approved for use by all Departments and Agencies of the Department of Defense.
2. Beneficial comments (recommendations, additions, deletions) and any pertinent data which may be of use in improving this document should be addressed to: Director, U.S. Army Materiel Command Packaging, Storage, and Containerization Center, ATTN: SDSTO-TE-S, Tobyhanna, PA 18466-5097, by using the self-addressed Standardization Document Improvement Proposal (DD Form 1426) appearing at the end of this document or by letter.
3. As indicated in the supersession data, the basic information provided in this document was presented previously in the form of a military specification. That information is reconstructed here in the military standard format because a standard "defines requirements for management, design processes, procedures," etc. (see MIL-STD-962). On the other hand, a specification is "prepared specifically to support acquisition" and "describes .... requirements for purchasing materiel." (See MIL-STD-961). The military standard format is more appropriate and is so provided along with additional, updated data and more detailed directions.

## MIL-STD-1191

## CONTENTS

<u>PARAGRAPH</u>		<u>PAGE</u>
1.	SCOPE . . . . .	1
1.1	Purpose . . . . .	1
1.2	Application . . . . .	1
1.3	Classification. . . . .	1
2.	APPLICABLE DOCUMENTS. . . . .	2
2.1	Government documents. . . . .	2
2.1.1	Specifications, standards, and handbooks . . . . .	2
2.1.2	Other Government documents. . . . .	3
2.2	Non-Government publications . . . . .	3
2.3	Order of precedence . . . . .	4
3.	DEFINITIONS (Not Applicable). . . . .	5
4.	GENERAL REQUIREMENTS. . . . .	6
4.1	Materials . . . . .	6
4.1.1	Foam chemicals. . . . .	6
4.1.2	Toxic and hazardous materials . . . . .	6
4.1.3	Use of recycled polyurethane. . . . .	7
4.2	Sensitive items . . . . .	7
4.3	Safety and health considerations. (occupational and environmental). . . . .	7
4.3.1	Purging dispensing head . . . . .	8
4.3.2	Pyrolysis . . . . .	8
4.3.3	Combustibility. . . . .	8
4.3.4	Personal protective measures. . . . .	8
4.3.5	First aid . . . . .	8
4.3.6	Vapor detection . . . . .	9
4.3.7	Decontamination . . . . .	9
4.3.7.1	Clothing. . . . .	9
4.3.7.2	Spills. . . . .	9
4.3.7.3	Empty drum decontamination. . . . .	9
4.3.8	Waste management. . . . .	10
4.3.8.1	Purging solvents. . . . .	10
4.3.8.2	Decontamination waste . . . . .	10
4.3.8.3	Empty drum reclamation. . . . .	10
4.4	Unit protection . . . . .	10
4.5	Foam dispensing equipment . . . . .	10
4.6	Foaming conditions. . . . .	10
4.7	Predetermination of foam thickness. . . . .	11
4.8	Determination of foam volume (quantities) . . . . .	11
4.9	Utilization of restraining devices. . . . .	11
5.	DETAILED REQUIREMENTS . . . . .	12
5.1	General . . . . .	12
5.1.1	Technique I, split pack, standard . . . . .	12

## MIL-STD-1191

<u>PARAGRAPH</u>		<u>PAGE</u>
5.1.1.1	Technique I procedure . . . . .	12
5.1.2	Technique II, split pack, alternate . .	13
5.1.2.1	Technique II procedure . . . . .	13
5.1.3	Technique III, split pack, inverted . .	14
5.1.3.1	Technique III procedure . . . . .	14
5.1.4	Technique IV, foam-in-bag . . . . .	15
5.1.4.1	Technique IV procedure . . . . .	15
5.1.5	Technique V, special technique, . . . .	
	modified. . . . .	16
5.1.6	Technique VI, foamed container. . . . .	16
5.1.6.1	Technique VI procedure . . . . .	16
5.1.7	Technique VII, encapsulated pack. . . .	17
5.1.7.1	Selection of applicable design procedure for technique VII . . . . .	17
5.1.7.2	Technique VII procedure . . . . .	17
5.1.7.3	Special marking for technique VII packs	20
5.1.7.4	Reusability of technique VII packs. . .	20
5.1.8	Technique VIII, preformed molding . . .	21
5.1.8.1	Technique VIII procedure. . . . .	21
5.2	Performance characteristics . . . . .	22
5.2.1	Exterior appearance . . . . .	22
5.2.2	Rough handling damage . . . . .	22
5.2.3	Shock mitigation (flexible foams) . . .	22
5.2.4	Pack opening. . . . .	22
5.2.5	Completeness of fill. . . . .	22
5.2.6	Foam adherence. . . . .	23
5.2.7	Release of items. . . . .	23
5.2.8	Item condition. . . . .	23
5.2.9	Conditioning of pack. . . . .	23
5.3	Reusability . . . . .	23
5.4	Marking for shipment and storage. . . .	23
5.4.1	Special marking and labeling. . . . .	23
5.5	Foam workmanship. . . . .	23
5.5.1	Rigid foams . . . . .	24
5.5.2	Flexible and semirigid foams. . . . .	24
6.	NOTES . . . . .	25
6.1	Intended use. . . . .	25
6.2	Ordering data . . . . .	25
6.3	Sampling for Group B inspection . . . .	26
6.4	Opening and reusability information for technique VII packs . . . . .	26
6.5	Foam-in-place training. . . . .	27
6.6	Subject term (keyword) listing. . . . .	27
6.7	Changes from previous document. . . . .	27

## MIL-STD-1191

## CONTENTS

<u>FIGURES</u>		<u>PAGE</u>
1.	Design for flexible foam packs. . . . .	28
2.	Design of 0.5 pound density semirigid foam packs. . . . .	30
3.	Determination of tube/bag width for technique IV. . . . .	32
4.	Split pack, standard. . . . .	33
5.	Split pack, alternate . . . . .	34
6.	Split pack, inverted. . . . .	35
7.	Foam-in-bag . . . . .	36
8.	Foamed container. . . . .	37
9.	Encapsulated pack (design 1). . . . .	38
10.	Encapsulated pack (design 2). . . . .	38
11.	Encapsulated pack (design 3). . . . .	39
12.	Encapsulated pack (design 4). . . . .	40
13.	Encapsulated pack, special marking locations . . . . .	42
14.	Preformed mold. . . . .	43
 <u>APPENDICES</u>		
A.	Quality assurance provisions. . . . .	44
B.	English-metric conversions. . . . .	51
 <u>TABLES</u>		
I.	Test required for the procedure and foam formulation utilized. . . . .	47
II.	Standard English-metric equivalents . . . . .	51
III.	MIL-STD-1191 English-metric conversions . . . . .	52

## MIL-STD-1191

## 1. SCOPE

1.1 Purpose. This standard provides the requirements and procedures (techniques) for packaging supplies using foam-in-place (FIP) materials.

1.2 Application. Any one of the techniques classified below shall be employed when determined to be an effective packaging approach and when subsequently authorized, specified, or approved for use through the appropriate Government means. As a standard, it may be applied as an acquisition document accomplished accordingly by outside contractors, within its specified terms, or it may be implemented solely as a procedural document for accomplishment, as specified, by Government supply or support personnel. With the latter application, any augmental or supportive data, if needed in special instances, shall be supplied by the responsible packaging specialist, packaging engineer, or their equivalent using standard techniques and applicable reference materials (specifications, standards, packaging data sheets, or special packaging instructions). Sensitive items, as described in paragraph 4.2, shall not be packaged using FIP techniques without employing special precautions as specified.

1.3 Classification. The procedures covered by this standard shall be of the following techniques, as specified (see 6.2):

Technique I	Split pack, standard
Technique II	Split pack, alternate
Technique III	Split pack, inverted
Technique IV	Foam-in-bag
Technique V	Special technique, modified
Technique VI	Foamed container
Technique VII	Encapsulated pack
Technique VIII	Preformed molding

## MIL-STD-1191

## 2. APPLICABLE DOCUMENTS

2.1 Government documents.

2.1.1 Specifications, standards, and handbooks. The following specifications, standards, and handbooks form a part of this document to the extent specified herein. Unless otherwise specified, the issues of these documents are those listed in the issue of the Department of Defense Index of Specifications and Standards (DODISS) and supplement thereto, cited in the solicitation (see 6.2).

## SPECIFICATIONS

## FEDERAL

- |            |   |  |
|------------|---|--|
| A-A-883    | - | Tape, Pressure Sensitive Adhesive, Masking.                                      |
| FF-N-105   | - | Nails, Brads, Staples and Spikes, Wire, Cut and Wrought.                         |
| L-P-378    | - | Plastic Sheet and Strip, Thin Gauge, Polyolefin.                                 |
| NN-P-530   | - | Plywood, Flat Panel.   |
| PPP-C-1797 | - | Cushioning Materials, Resilient, Low Density, Unicellular Polypropylene Foam.    |
| PPP-F-320  | - | Fiberboard, Corrugated and Solid, Sheet Stock (Container Grade), and Cut Shapes. |
| PPP-T-60   | - | Tape, Packaging, Waterproof Filament Reinforced.                                 |
| PPP-T-97   | - | Tape, Pressure Sensitive Adhesive, Filament Reinforced.                          |
| UU-P-268   | - | Paper, Kraft, Wrapping.  |

## MILITARY

- |             |   |   |
|-------------|---|---|
| MIL-P-116   | - | Preservation, Methods of.   |
| MIL-B-117   | - | Bag, Sleeve and Tubing - Interior Packaging.                          |
| MIL-B-121   | - | Barrier Material, Greaseproofed, Waterproofed, Flexible.              |
| MIL-B-81705 | - | Barrier Materials, Flexible, Electrostatic Protective, Heat Sealable. |
| MIL-F-83671 | - | Foam-In-Place Packaging Materials, General Specification for.         |
| MIL-F-87075 | - | Foam-In-Place Packaging Systems, General Specification for.           |

MIL-STD-1191

STANDARDS

MILITARY

- MIL-STD-129 - Marking for Shipment and Storage.
- MIL-STD-731 - Quality of Wood Members for Containers and Pallets.

(Unless otherwise indicated, copies of federal and military specifications, standards, and handbooks are available from Military Specifications and Standards, Bldg. 4D, 700 Robbins Avenue, Philadelphia, PA 19111-5094.)

2.1.2 Other Government documents. The following other Government documents form a part of this standard to the extent specified herein. Unless otherwise specified, the issues shall be those cited in the solicitation.

Code of Federal Regulations (CFR)

- Title 40, Part 261 - Identification and Listing of Hazardous Waste.

(Copies of Title 40, Part 261 are available from the Superintendent of Documents, U.S. Government Printing Office, Washington, DC 20402-0001.)

2.2 Non-Government publications. The following documents form a part of this document to the extent specified herein. Unless otherwise specified, the issues of the documents which are DOD adopted are those listed in the issue of the DODISS cited in the solicitation. Unless otherwise specified, the issues of documents not listed in the DODISS are the issues of the documents cited in the solicitation (see 6.2).

- Voluntary Product Standard PS-1 - Plywood, Construction and Industrial.

(Application for copies should be addressed to American Plywood Association, 7011 South 19th Street, P.O. Box 11700, Tacoma, WA 98411.)

American Society for Testing and Materials (ASTM)

- ASTM D-3950 - Standard Specification for Strapping, Plastic (and Seals).
- ASTM D-3953 - Standard Specification for Strapping, Flat Steel (and Seals).



**MIL-STD-1191**

(Application for copies should be addressed to the American Society for Testing and Materials, 1916 Race Street, Philadelphia, PA 19103.)

**2.3 Order of precedence.** In the event of a conflict between the text of this document and the references cited herein, the text of this document takes precedence. Nothing in this document, however, supersedes applicable laws and regulations unless a specific exemption has been obtained.

**MIL-STD-1191**

**3. DEFINITIONS**

**This section is not applicable to this standard.**

## MIL-STD-1191

## 4. GENERAL REQUIREMENTS

4.1 Materials. Associated materials required to facilitate the development of FIP packs shall be as specified herein and up-to-date material safety data sheets (MSDS) shall be included.

4.1.1 Foam chemicals. The FIP chemicals and characteristic end product shall conform to the requirements of MIL-F-83671 and shall be selected for the prescribed procedure from the approved classes and grades/categories specified (see 6.2). Additionally, the applied foams shall conform to the workmanship requirements of 5.5.

4.1.2 Toxic and hazardous materials. The individual foam chemicals are classified as toxic or hazardous in their original state and, also, when combined during the mixing process. Once reacted, the foam is hazardous only as dust or if ingested. Further hazards can occur when materials are not stored properly, dispensing equipment is not maintained correctly, or purging operations are improperly performed (see 4.3.1). Additional information on safety and maintenance procedures for the storing, handling, and use of the involved chemicals and equipment can be found in the respective manufacturer's safety and maintenance manuals, the availability of which is required by the Occupational Safety and Health Administration (OSHA) (see 4.3). It should be noted, too, that where available, ozone-safe chemical systems (those combinations of chemicals and dispensing equipment that do not employ chlorofluoro carbon-blowing agents) should be used. A partial list of significant foam chemicals along with their hazards and potential effects are given below.

a. Di and polyisocyanates (component A). This is a skin irritant, harmful to eye tissues, that causes bronchospasm and respiratory tract sensitization in susceptible individuals.

b. Trichlorofluoromethane (typical blowing agent). Prolonged breathing of high concentration can cause unconsciousness and anesthesia leading to asphyxiation.

c. Silicone oils (cell control agents). Low toxicity but repeated contact should be avoided.

d. Phosphate esters (for flame retardancy). Phosphate esters are readily absorbed through skin causing blurred vision, nausea, headaches, abdominal cramps, coughing, and breathing difficulties.

e. Amines (catalysts). Vapors are eye irritants and can irritate mucous membranes. Aliphatic amines can produce skin burns and dermatitis and are a respiratory irritant.

## MIL-STD-1191

f. Methylene chloride (purging solvent). Methylene chloride is a skin and respiratory irritant that can also act as a chemical asphyxiant. It is a solvent that can result in skin, eye, liver, respiratory tract, and central nervous system toxicity.

g. Ethylene glycol monoethyl ester (cleaning solvent). It is a skin and respiratory irritant.

h. Dioctyl or diallyl phthalate (plasticizer/lubricant). It is a skin and respiratory irritant.

4.1.3 Use of recycled polyurethane. Recycled polyurethane shall be the same category, class, or grade of MIL-F8367 as that of the new foam to be dispensed. The use of recycled polyurethane shall be limited only to the extent that formed foam packs meet the performance requirements of this standard and that such reused foam does not exceed 50 percent of the total foam volume. Recycled polyurethane foam shall not be used as filler for technique VII packs.

4.2 Sensitive items. Unless the contract specifies otherwise (see 6.2), FIP techniques shall be used only on items that are not susceptible to either electrostatic discharge (ESD) or high temperatures because FIP operations are enormous generators of both ESD voltage and exotherm heat (up to 150° F.) (66° C.). When the use of FIP techniques are permitted by contract on ESD sensitive items, they should be enclosed in a static-shielding wrap or barrier material in accordance with MIL-B-81705. Parting or separating film shall be limited to electrically conductive, anti-static types also in accordance with MIL-B-81705. When a FIP technique is permitted by contract for use with an item that is sensitive to high exotherm heat, the item shall not be placed in direct contact with the separating film or rising foam. The preferred FIP method for packing such heat-sensitive items is technique VIII, preformed molding. Note: Exothermic heat is not a concern for this technique.

4.3 Safety and health considerations (occupational and environmental). All chemicals and materials required for FIP packaging shall be ordered and furnished with up-to-date material safety data sheets. For contract application, the appropriate OSHA standard shall be specified and followed. Any potential hazards resulting from the use of FIP procedures should be minimized through the use of proper preventive measures and controls. When acquiring FIP services from outside contractors, specific safety guidance can be obtained from specific manufacturer's required safety and maintenance manuals. Both contractors and Government personnel can also obtain such safety guidance from local industrial hygiene, medical, and safety personnel. Moreover, any FIP dispensing operations within DoD installations and facilities (land and afloat)

## MIL-STD-1191

shall have medical service available for environmental health or safety approval regarding ventilation and protective equipment requirements.

4.3.1 Purging dispensing head. If solvent purging of the dispensing head is used, it is recommended that the discharge solvent be directed into a container containing approximately 1 inch of water. This action will limit the escape of solvent (methylene chloride) vapors (see 4.1.2). Workers should use the appropriate skin, eye, and respiratory protection as designated by local industrial hygiene personnel.

4.3.2 Pyrolysis. Smoking in foaming areas shall be prohibited. This is required due to the pyrolysis breakdown products and not the flammability characteristics of the foam chemicals.

4.3.3 Combustibility. Combustion of solid foam and the foaming ingredients produce toxic gases, as do most packaging materials. In the event of fire, the local fire departments shall be immediately notified. Full face, self-contained breathing apparatus shall be employed for these fires. For small fires CO<sub>2</sub> or dry chemical fire extinguishers are suitable.

4.3.4 Personal protective measures. Protective measures involved with foaming operations include proper training, assignment of personal safety equipment, location of approved emergency facilities, and the designation of safe operating and reporting procedures. Eye wash fountain(s) and shower(s) should be located in the immediate foaming area or readily accessible thereto.

4.3.5 First aid. If chemicals containing isocyanates (primarily component A) are splashed on the skin, treatment should be started immediately as follows:

- a. Shower immediately (major splash only).
- b. Apply tincture of green soap (full strength) or rubbing alcohol to the remaining contaminated area.
- c. After 2 to 4 minutes, wash off the tincture of green soap or rubbing alcohol with water. If there is still an indication of isocyanate present, another application will be necessary. If the isocyanate contamination is on the face, care should be taken to prevent getting the tincture of green soap in the eyes.
- d. When polyol component (component B) is splashed on the skin, it should be washed away with soap and water.

## MIL-STD-1191

e. If either component is splashed in the eyes, the eyes should be flushed immediately with clean water for 15 minutes. The eyelids should be held apart during this treatment. Medical attention should be promptly obtained.

f. If a person accidentally swallows the isocyanate component and is conscious, dilute by having the victim drink milk or water and transport him to a physician immediately. If a person is overexposed to the vapors of components, he should be removed from exposure immediately and transported to a physician. Oxygen may be administered by qualified personnel en route if the exposed person has difficulty breathing.

4.3.6 Vapor detection. Field detection must be performed under the direction of trained industrial hygiene personnel. Interpretation of sampling data must be performed by appropriate industrial hygiene or medical personnel. The maximum allowable concentration of diphenyl methane diisocyanate in a worker's breathing zone is 0.005ppm.

4.3.7 Decontamination.

4.3.7.1 Clothing. Clothing splashed with the polyol component should be removed and washed in an aqueous detergent solution before wearing again. Clothing splashed with the isocyanate component should be removed immediately, the isocyanate scraped off the clothing, and the clothing washed in an aqueous detergent solution. In the case of large spills that have soaked through clothing, wash clothes in an aqueous detergent solution before discarding.

4.3.7.2 Spills. Accidental floor spills may be decontaminated by covering with an absorbent material such as absorbent shredded paper, sawdust, Fuller's earth, or other absorbent material. If amine fumes are present, a vapor cartridge-type respirator should be used. Pour liquid decontaminant consisting of 90 to 94 percent water, 4 to 8 percent concentrated ammonium hydroxide, and 2 percent detergent on the spillage and allow to react for at least 10 minutes. Carefully remove all residues from the spill, placing them in open containers, and add further amounts of liquid deconcentrate. After removing containers to a safe place, the floor may be washed with liquid decontaminant, soapy water, or an ammonia solution.

4.3.7.3 Empty drum decontamination. Polyol drums may be decontaminated with soapy water and reclaimed through any suitable outlet. Isocyanate drums may be decontaminated by slowly adding the liquid decontaminant. Under no circumstances should the drums be closed. After 24 to 48 hours, the drums may be drained (see 4.3.8) and pierced to prevent reuse.

## MIL-STD-1191

**4.3.8 Waste management.** All waste (liquid or solid foam) should be disposed of in a manner that will minimize pollution and enhance the environment. The first consideration in waste management shall be reuse or recycling. Applicable directives and local environmental authorities should be consulted before complete disposal of these materials is attempted.

**4.3.8.1 Purging solvents.** Some operations use solvents such as methylene chloride (dichloromethane) to clean foam mixing and dispensing equipment. Wastes from these mixtures of solvent and foam components must be managed as a hazardous waste with Environmental Protection Agency No. F001 (CFR 40, 261).

**4.3.8.2 Decontamination waste.** The appropriate regulatory activity designates acceptable methods of disposing of reacted (neutralized) waste solution.

**4.3.8.3 Empty drum reclamation.** Reclamation of decontaminated drums is preferable to landfill disposal. Alternatively, empty drums, as defined in 40 CFR, 261.7, may be accepted at sanitary landfills by special arrangement and with the concurrence of state regulatory authorities.

**4.4 Unit protection.** Unit protection requirements shall be applied in accordance with MIL-P-116 or other applicable documents as specified (see 6.2) prior to the application of the specified FIP technique. When required, wrap-type cushioning material shall be used to cover projections, sharp edges, or curves of the item.

**4.5 Foam dispensing equipment.** Any equipment may be used provided that as a foaming system it is in accordance with the requirements of MIL-F-87075. A foaming system consists of the chemicals and the dispensing equipment together. Both must be compatible and produce finished foam that is in accordance within requirements of MIL-F-83671.

**4.6 Foaming conditions.** All components, surfaces, wraps, and void areas of the proposed foam pack to be filled should be conditioned and maintained at a constant temperature within the limiting temperature range of 60° F. (16° C.) to 100° F. (38° C.) to ensure efficient, continuous foam production and for retention of optimum foam properties. Chemical ingredients shall not be exposed to temperatures other than those recommended by the formulation supplier. Surfaces expected to come in contact with the foaming chemicals shall be free of grease, oil, loose particles, moisture, and other deleterious (harmful) foreign matter.

## MIL-STD-1191

**4.7 Predetermination of foam thicknesses.** Unless otherwise specified (see 6.2), minimum foam thickness determination shall be made, as specified herein. In the case of flexible foams, cushioning requirements are based on item static-bearing stress and fragility (see figure 1). For rigid foams, minimum thickness shall be 2 inches (5.08 cm). Where semirigid foam is intended for use with items weighing 150 pounds (68.10 kg) or less, constraints are also based on load bearing of the prepared item. In this specific application, a "new" bearing surface can essentially be formed around items of irregular configurations so that minimum allowable surface areas can be met (see figure 2 for 0.5 pound density). For special application of technique IV procedures, thickness determination listed in figure 3 may be used. However, the final thickness determination will be based on results of the rough handling tests specified (see 6.2).

**4.8 Determination of foam volume (quantities).** The amounts of foam may vary based on the characteristics of the void area. In general, cool surfaces or low environmental temperatures will retard normal foaming action and require additional chemical components. Adjustment of foam quantities will normally be necessary after foaming initial packs.

**4.9 Utilization of restraining devices.** Foaming bucks or restraining blocks shall be fabricated of any appropriate material in sufficient quantity to prevent distortion of container walls during foaming operations. The selected design shall be based on the procedure technique used and of such construction as to allow for some venting and subsequent release of entrapped gases. Additional restraining devices shall be used, as necessary, to limit the tendency for certain items to "float" or move from their designated orientation during foam rise. Pressures actually developed are dependent upon the class and grade of foam material used.



## MIL-STD-1191

## 5. DETAILED REQUIREMENTS

**5.1 General.** This section contains the detailed, step-by-step requirements to be followed for accomplishment of each of the eight FIP packaging techniques classified in section 1. Each technique shall utilize foam materials as specified in 4.1. All items to be packed using FIP procedures shall be protected as specified in 4.4. Also, in each case, the term "prepared item dimensions" refers to the dimensions of the item along with all the pads, wraps, or other materials needed to prepare or make this item ready for the foaming operations. Unless otherwise specified within the requirements of a specific technique, the prepared items shall be enclosed in a container as specified by the contract (see 6.2). Specific applications, requirements, or anticipated results that are unique to a particular technique preface each procedure.

**5.1.1 Technique I, split pack, standard.** This procedure is adaptable for many various items. It shall be achieved using a minimum of two consecutive pours with time allowed between each pour to permit the foam to set (become tack free). The foam materials shall be of the class specified (see 6.2).

**5.1.1.1 Technique I procedure (see figure 4).**

**Step a.** Select the best orientation for the item considering the ready availability of supporting surfaces. The orientation selected shall also depend on the locations of critical item projections and the item void areas that could later cause removal of the item to be difficult.

**Step b.** Select container of appropriate dimensions.

**Step c.** Drape plastic sheet film as specified in L-P-378 loosely inside container covering bottom and extending over flaps, where applicable. Smooth the sheet toward all corners. Tape, if necessary, to hold temporarily. The following formulas shall be used to tabulate film requirements:

Sheet length =  $2 \times \text{depth} + 1.5 \times \text{length of container interior}$   
 Sheet width =  $2.5 \times \text{depth} + \text{width of container interior}$

**Step d.** Place prefoamed support block to support weight of prepared item to required height in container bottom. Position to support item uniformly.

**Step e.** Remove item. Then dispense enough foam mix into the container to encase block(s) and allow to rise to the required height which is approximately to the middle of the item. This is the first pour.

## MIL-STD-1191

Step f. Fold plastic film inward completely covering foam before it completes its rise.

Step g. Immediately place and hold prepared item on top of the plastic film/foam and the foam support until foam has risen completely and set enough to support the item. (Some items have a tendency to float during foaming.)

Step h. Drape a second sheet of plastic film loosely inside the container, covering the prepared item and foam. Extend film over flaps. Tape film, if necessary, to hold temporarily.

Step i. Dispense a sufficient amount of foam mix into the container to surround the item and fill the container with expanded foam. This is the second pour.

Step j. Fold the plastic film inward when certain that the rising foam will fill the container. Fold the container flaps over, but do not secure. If the container becomes overfilled, trim off excess.

Step k. Apply appropriate closure. Allow time for foam to set before moving container.

5.1.2 Technique II, split pack, alternate. This procedure is a variation of technique I, split pack, that provides a more simple means of completing foam packs for use in remote areas or aboard ship and for retrograde materials or items that must be rapidly deployed. Time shall be allowed between each pour to permit the foam to set (tack free) properly. Note that prefoamed support blocks are not used. Foam materials shall be of the class specified (see 6.2).

5.1.2.1 Technique II procedure (see figure 5).

Step a. Select the best orientation for the item considering the ready availability of support surfaces. The orientation selected shall also depend on locations of critical item projections and the item void areas that may later cause difficult removal of the item. Protective material shall be used only as required to prevent puncture of the plastic sheet which would subsequently alleviate the danger of the poured foam contacting the item or locking the molded halves together.

Step b. Select specified container to hold prepared item.

Step c. Drape sheet plastic film as specified in L-P-378 loosely inside the container covering bottom and extending over flaps. Tape, if necessary, to hold temporarily.

## MIL-STD-1191

Step d. Dispense sufficient amount of foam mix into the container to center item in container. Fold plastic film inward completely covering foam as it completes its rise.

Step e. Place prepared item, overwrapped in plastic(L-P-378), on the foam surface after foam has risen and set enough to support the item. (The item shall be centered in container.)

Step f. Drape a second sheet of plastic film loosely inside the container covering the prepared item and foam. Extend film over flaps. Tape film, if necessary, to hold temporarily.

Step g. Dispense a sufficient amount of foam mix into the container to surround the item and fill the container with expanded foam.

Step h. Fold the plastic film inward when certain that the rising foam will fill the container. Fold container flaps over, but do not secure. If the container becomes overfilled, trim off excess.

Step i. Apply applicable closure. Allow time for foam to set before moving container.

5.1.3 Technique III, split pack, inverted. The inverted pack shall not be used for items that must always remain in an upright position to prevent internal damage. Foam material shall be of the class specified (see 6.2).

5.1.3.1 Technique III procedure (see figure 6).

Step a. Select the best orientation for the item considering the ready availability of supporting surfaces. The orientation selected shall also depend on locations of critical item projections and the item void areas that may later cause difficult removal of the item.

Step b. Select specified container to hold prepared item.

Step c. Cut a pad(s) of foam the same length and width as the container's inside dimensions and a depth equal to the thickness of the foam to be poured. This will result in the item being centered vertically in the container.

Step d. Place prepared item upside down on the foam pad, centered in the container.

Step e. Drape a sheet of plastic film as specified in L-P-378 loosely inside the container covering the prepared item and foam pad and extending over the flaps. Tape, if necessary, to hold temporarily.

## MIL-STD-1191

Step f. Dispense enough foam mix into the container to surround the item and fill container with expanded foam.

Step g. Fold the plastic film inward when certain that the rising foam will fill the container. Fold container flaps over, but do not secure. If the container becomes overfilled, trim off excess before taping.

Step h. Foam must be able to support item weight before container is turned upright. After foam is cured 15 minutes, invert container to upright position.

5.1.4 Technique IV, foam-in-bag. This procedure is adaptable to a wide variety of items regardless of dimension. When items exceeding approximately 32 inches in length are being foamed, it is preferable to use a multiple bag unit design. Foam material shall be of the class specified (see 6.2).

5.1.4.1 Technique IV procedure (see figure 7).

Step a. Select the best orientation for the item while considering the ready availability of supporting surfaces. The orientation selected shall also depend on locations of critical item projections and the item void areas that may later cause difficult removal of the item.

Step b. Select container of appropriate dimension (specific container or restraining device) based on prepared item dimension.

Step c. Determine dimensions (see figure 3) and fabricate or select bags (or tubes) fabricated from plastic film as specified in L-P-378 in the width (diameter) and thickness, as specified (see 6.2), that are necessary to hold the item immobile in the container. Tubes shall be heat sealed transversely at the center line to form two compartments. The flat tubing dimension shall be determined by the interior dimension of the container or restraining device. Formulas shall be used as follows:

$$\begin{aligned} \text{Tubing length (LT)} &= 2 \times \text{depth} + \text{width} + 4 \text{ inches (10.16 cm)} \\ \text{Tubing width (WT)} &= \text{length} + \text{width} + 2 \text{ inches (5.08 cm)} \end{aligned}$$

Step d. Prepare a sufficient number of cut prefoamed blocks (see 4.1.3) to support the prepared item to its required height above the bottom of the container during the foaming operation. Place these prefoamed blocks inside the bags or tubes in close proximity to the common heat seal; then position inside the container. The bags or tubes may be taped or clipped to the container walls or flaps to hold them in place to facilitate easier dispensing of foam mix.

## MIL-STD-1191

Step e. Position the prepared item in the center of the container supported by the foam blocks inside the tubes.

Step f. Dispense equal amounts of the foam mixture into each set of bags or tubes. Hold the prepared item in place until foam has risen and set enough to support the item. When foam reaches half of its rise, remove any tape or clips holding the bags to the container.

Step g. Overlap the tube or bag ends, and fold the container flaps over temporarily until rise has stopped. Do not secure. Open the container to make sure that the item is immobilized by the bags and allow the foam to cure 15 minutes before handling. Close flaps and secure with tape.

5.1.5 Technique V, special technique, modified. Whenever the particular nature of an item (configuration, size, fragility, or any other unique aspect or combination thereof) dictates deviations from the FIP procedures specified in techniques I through IV, those deviations must be recognized as special, the necessary packaging adaptations shall be invoked, and the resultant procedure shall be designated, technique V. When employing this technique in the acquisition process the special procedures, instructions, and descriptions necessary shall be included as shown in 6.2; as a procedure by Government personnel, apply as specified herein (see 1.2).

5.1.6 Technique VI, foamed container. This procedure is essentially a split pack using special fabrication techniques and should be used primarily with large, heavy items. Foam material shall be of the class specified (see 6.2). Specific fabrication procedures shall be developed by the fabricator to meet the requirements of the engineering drawing/specification (see 6.2). The following design steps are intended for general guidance only.

5.1.6.1 Technique VI procedure (see figure 8).

Step a. Set up the specified mold for fabricating the foamed container (a simulated item can be used). Mold design shall allow easy disassembly that will ensure against damage of the foamed container upon removal.

Step b. Apply release material (plastic sheet (L-P-378), wax coatings, etc.) to the inside surfaces of the mold and completely around or on the surfaces of the item. Tape plastic sheet, if necessary, to hold in place temporarily.

Step c. Position inserts such as base with skids, push plates, tiedown rings, or reinforcements in the mold and secure.

## MIL-STD-1191

Step d. Position and secure item in the proper location in the mold. The item can be suspended from a hoist or supported with prefoamed blocks.

Step e. Dispense the required quantity of foam into the mold so that the total rise reaches approximately one-half of the depth of the item. Where consecutive pours are necessary, time is required between each pour to allow the foam to set properly.

Step f. Apply release materials to the top surfaces of the risen foam.

Step g. Dispense the required quantity of foam into the remaining void so that it surrounds the prepared item completely. Consecutive pours are performed as in step e above.

Step h. When it can be seen that the rising foam will fill the mold, place and secure the lid. The lid may contain holes to allow release of excess expanded foam and gases. Allow the foam to cure for 15 minutes before moving or opening the mold.

Step i. Remove foamed container from mold. Apply edge protectors for strapping.

Step j. Coat outside surfaces of foamed containers as required by engineering drawing/specifications. Assemble and secure closure.

5.1.7 Technique VII, encapsulated pack. In this procedure, items are completely surrounded (encapsulated) in a minimum 2-inch thickness of foam to achieve watervapor protection. Foam material shall be of the class specified (see 6.2).

5.1.7.1 Selection of applicable design procedure for Technique VII (see 6.2):

Design 1. Small items, 0 to 100 pounds (45.4 kg) (see figure 9).

Design 2. Intermediate items, 75 (34.05 kg) to 125 pounds (56.75 kg) (see figure 10).

Design 3. Intermediate items, 100 (45.4 kg) to 250 pounds (113.50 kg) (see figure 11).

Design 4. Large or dense items, 150 (68.10 kg) to 400 pounds (181.6 kg) (see figure 12).

Design 5. Special items, as specified by procuring activity.

5.1.7.2 Technique VII procedure.

## MIL-STD-1191

**Step a.** Select the best orientation for the item considering the ready availability of supporting surfaces. The orientation selected shall also depend on locations of critical item projections and the void areas that may later cause removal of the item to be difficult.

**Step b.** Select container and applicable designs based on item dimension, weight, minimum foam thickness (see step g below), wrap, protective sleeve, and the orientation determined in step a above. For design 2, the container shall be fastened to the skid by driving nails in two parallel rows, spaced alternately 3 inches (7.62 cm) apart, through the batten and container into each skid post. For designs 3 and 4, first the plywood base shall be secured to the skid. This is done by driving nails in two parallel rows, spaced alternately 3 inches (7.62 cm) apart, through the bases as shown in figures 11 and 12. Also, for design 4, the top frame shall be constructed prior to securing it to the container shell and then pressed into position and secured to the shell using metal staples or nails in the same way that the shell is secured to the base. This must be accomplished prior to the final pour of foam.

(1) For securing bases and containers to skids, use pallet nails conforming to FF-N-105, type II, style 18, minimum of 2.5 inches (6.35 cm) long.

(2) All wood used in type VII packs shall conform to MIL-STD-731, groups II or III, class 2.

(3) All plywood bases used shall conform to NN-P-530, 5-ply, standard-interior with exterior glue, group PS-1, grades C-C. Quality shall conform to PS-1.

(4) Unless otherwise specified (see 6.2), containers shall be fabricated from fiberboard conforming to PPP-F-320, grade V3c, type CF, class WR. Container dimensions shall be inside measurements and shall be cited in the sequence of length, width, and depth. The length dimensions shall be the larger of the two dimensions of the open face of the box, and the depth dimension shall be perpendicular to the length and width.

**Step c.** Prepare properly sized prefoamed blocks to support the item in a stable position during the foaming procedure. Blocks must be cut and positioned so that the direction of foam rise (maximum compressive strength) is supporting the item. This is very important on heavy items to prevent blocks from collapsing. Class and grade of foam shall be identical to the foam ingredients to be used (see 4.1.1).

**MIL-STD-1191**

The thickness of the blocks shall be determined by the requirement for critical centering of the item between the top and bottom planes of the receptacle. Additionally, load-bearing material such as fiberboard or plywood may be further required to distribute concentrated loads over the area of the foam blocks thereby preventing compression and damage to the foam blocks prior to foaming.

Step d. With the item supported on the blocks, determine the cut line in the horizontal plane that will best permit removal of the top cut section of the foamed pack and subsequent removal of the item from the remaining bottom section.

Step e. A protective sleeve shall be fabricated to contour to the item as closely as possible and be positioned horizontally around the item so that the cut line marking to be applied on the exterior of the container will be located at the vertical center of the sleeve. The sleeve shall be fabricated and formed using fiberboard material conforming to type CF, grade V3c, class WR, PPP-F-320. The sleeve shall be secured in place with tape conforming to PPP-T-97 and drawn tightly to the item under adequate tension. This sleeve is designed to provide protection to the item during the cutting operation when opening, and to facilitate the removal of both the top of the container and the item from the base section. For large container designs, at this point, preliminary foaming into selected plastic bag sizes conforming to MIL-B-117 (4-mil) may be used for filling large void areas between the sleeve and the item (regularize configuration). Similarly, properly sized filler blocks built up of fiberboard sheet stock may be used. This process will ensure support to the sleeve against anticipated external pressure from the expanding foam in step g below. Care shall be exercised to ensure that there are no projections beyond the plane formed by the sleeve.

Step f. Two pieces of barrier material, one conforming to MIL-B-121, type I, grade C, class 1 and the second conforming to UU-P-268, type I, grade B, 40-pound (18.16 kg) basis weight (minimum) shall be prepared of such dimension as to completely encircle the item with sleeve attached. The first wrap, MIL-B-121, shall be applied with the "face" or wax-free side toward the item. Both wraps shall be applied in such a manner to conform to the contour of the item and shall not be loosely applied. Caution shall be taken to insure that no rips, tears, or holes are present in the wraps exposing any part of the item prior to application of foam. The overlaps (wrap joints) shall be rolled and pressed to ensure that the foam does not enter the wraps and contact the item. Secure and seal outer kraft wrap joints, tucks, folds, seams, etc., with A-A-883 tape, 2-inch (5.08 cm) width minimum.

Step g. The wrapped item shall have a minimum clearance between the container walls and the outermost projections of the wrapped item, as specified (see 6.2).



## MIL-STD-1191

Step h. The amount of foam specified (see 6.2) should only be used as a guide. Exact amount required is the responsibility of the packaging activity. Dispense foam into the void using successive pours, as required, ensuring that any additional pour is dispensed at the tack free point of the previous pour. The amount actually used per pack can be greatly influenced by the type of equipment used, foam formulation, atmospheric conditions, facilities, etc. Sufficient quantities of foam shall be dispensed to provide total volume fill. Furthermore, for design 4, the polyurethane foam must lay level with the top of the 2- by 2-inch (5.08 cm) top frame around the circumference of the pack to permit the plywood cover to be nailed flush to that 2- by 2-inch (5.08 cm) top frame and still meet the performance characteristics of the pack. Also, for design 4, the scored lip, 1.5-inch dimension (3.81 cm) of the shell, shall be folded over 90° onto the top frame and secured in place (see figure 12, inset).

Step i. Close container with PPP-T-60, 2-inch (5.08 cm) wide tape for designs 1, 2, and 3. Design 4 shall be closed by nailing a minimum .375-inch (0.95 cm) thick plywood cover to the top frame using pallet nails conforming to FF-N-105, type II, style 18, minimum of 1.625 inches (4.13 cm) long. Nailing shall be in a staggered pattern with nails not over 4 inches apart. The plywood cover shall not be nailed to the top frame until the foam pack has been inspected for 100 percent fill and allowed to set up for a minimum of .12 hours. All plywood covers shall be minimum .375-inch (0.95 cm) thick and shall extend to the outer edge of the ends and sides. The plywood shall conform to PS-1 and shall be of full exterior exposure durability and a minimum grade C-C.

5.1.7.3 Special marking for technique VII packs. Each design in technique VII shall include the special markings as illustrated in figure 13. (Special markings shall be limited to stenciling, printing, or silk screening per MIL-STD-129. Labels are not permitted for any marking other than bar coding and shipping label.)

5.1.7.4 Reusability of technique VII packs.

a. Reusability of technique VII packs is limited to the return of the unserviceable part.

b. Once the pack is opened, the item is subject to environmental deterioration and should be stored indoors under controlled conditions.

c. All technique VII packs opened for quality conformance inspection shall not be reused or repaired and shall be disposed of (see 6.4).

## MIL-STD-1191

5.1.8 Technique VIII, preformed molding. This procedure is specifically intended to form individual mold halves for items using a specially designed molding box or jig. An essential part of this procedure is that a very rigid molding fixture is required. It is also the means for vacuum withdrawal of air to ensure close conformity of the plastic release material to the simulated surfaces of the item, the container, and the mold mating surfaces. Technique VIII readily permits the forming of foam molds that would fit a variety of shipping containers other than those having a solid, rectangular shape. Thus, contoured molds may be formed intended for shipment in cylindrical containers or cans. Mating molds may be fabricated in advance of the actual packaging process. Due to the nature of the preformed molding procedure, a single pour of foam is preferred for each mold half. Foam material shall be of the class specified (see 6.2).

5.1.8.1 Technique VIII procedure (see fig 14).

Step a. Select applicable prefabricated mold fixture.

Step b. With the vacuum source connected, drape a 2-mil polyethylene sheet over the simulated item half and fixture flat surfaces, allowing sufficient overlap to completely cover the underside of the securing lid. With the vacuum source operating, ensure that the plastic sheet is pulled flat and tightly creased, where necessary, over these surfaces. Leave the vacuum source on during the following steps.

Step c. Dispense sufficient foam (single pour) into the prepared mold fixture.

Step d. Secure the plastic-lined lid over the rising foam in the fixture. Allow the filled mold to set for 15 minutes without handling or until it has sufficiently cured to prevent distortion of the molded foam.

Step e. Carefully remove the finished mold half from the fixture and check for conformity on all surfaces.

Step f. Duplicate steps b through e to produce a mating mold half.

Step g. Wrap the item, if required, in accordance with the configuration used for item shape simulation, as in step a above. Place in formed mold halves and insert entire assembly in selected shipping container.

Step h. Close container and secure with tape.

## MIL-STD-1191

**5.2 Performance characteristics.** The packs formed using the FIP techniques specified in 5.1 shall be acceptable for their intended purpose and shall be capable of passing the tests and examinations specified in appendix A.

**5.2.1 Exterior appearance.** When inspected, as specified in appendix A, 30.5.2, the exterior of the pack shall be free from surface distortions measuring in excess of 0.25 inch (.64 cm) per 12 linear inches (30.48 cm) of container. Packs possessing skids or specialized bases and exceeding 150 pounds (68.1 kg) in gross weight shall be checked for base distortion while the base is resting on a flat surface. Surface distortion measurements shall not be more than 0.50 inch (1.27 cm) above the supporting surface at any point on the perimeter of the pack base. Opening and reusability instruction markings shall be as specified for the selected procedural design and as further identified in 5.1.7.3.

**5.2.2 Rough handling damage.** There shall be no evidence of exterior pack deficiency or item looseness within the foam molds that affects the integrity of the pack or damage to the item when subjected to the appropriate rough handling test specified in appendix A, 30.5.3.

**5.2.3 Shock mitigation (flexible foams).** When specified (see 6.2), packs shall be capable of protecting items against the imposition of accidental shocks above prescribed fragility levels. Shock mitigation afforded by the flexible FIP material shall be consistent over the temperature extremes from -20° F. (-29° C.) to +125° F. (52° C.), and shall not exceed the specified fragility level when subjected to the free fall drop test specified in 30.5.3.1 of appendix A. There shall be no exception to this requirement due to either weight or dimension (see appendix A, 30.5.4).

**5.2.4 Pack opening.** FIP packs shall be fabricated in such a manner that the container can be opened and reclosed without damage to the item or cushioning material. Failure to meet this requirement shall be cause for rejection (see appendix A, 30.5.4 and 30.5.5). This is not the case with technique VII packs that have been opened for quality conformance inspection. Those shall not be reused or repaired except for the return of an unserviceable part (see 5.1.7.4 and appendix A, 30.5.8).

**5.2.5 Completeness of fill.** The resultant foam formed in the packs shall provide, as nearly as possible, a complete fill of the intended void space. Severe rounding off of interior container corners, excessive noncontact (bridging) over desirable item bearing surfaces, large void areas, and evidence of incomplete bonding of prefoamed materials shall not be permitted. For technique VII, foam

## MIL-STD-1191

must fill 100 percent of the container. No bridging (noncontact) over item surfaces shall be permitted. Voids or evidence of incomplete bonding shall not be permitted (see appendix A, 30.5.4 and 30.5.5).

**5.2.6 Foam adherence.** There shall be no evidence of foam breakthrough or penetration or adherence either on the item, intimate wraps (except special wraps) (see 4.2), sealed bags, inner surfaces of containers (except where foam is applied directly against container walls), or restraining bucks (see appendix A, 30.5.4 and 30.5.5).

**5.2.7 Release of items.** Items shall be easily removed from the foam molds with no evidence of accidental sealing between wraps, parting films, or bags. There shall be no evidence of locked items caused by improper application of multiple pours or excessive pressures created by void overfills (see appendix A, 30.5.4 and 30.5.5).

**5.2.8 Item condition.** Items shall show no evidence of damage resulting from the application of FIP materials. Apparent damage may include broken or distorted projections, loosening of mountings, broken wires, or scorched painted surfaces (see appendix A, 30.5.4 and 30.5.5). Humidity indicators, if used, shall indicate a safe condition.

**5.2.9 Conditioning of pack.** When specified (see 6.2), the pack shall be conditioned for 24 hours at a temperature of  $-20^{\circ}$  F. ( $-29^{\circ}$  C.) (see appendix A, 30.5.4).

**5.3 Reusability.** Formed foam molds are reusable when the prescribed procedures are followed, as required in 5.1 (see appendix A, 30.5.8), except for technique VII which does not provide water-vapor protection after the original seal is broken and, thus, shall not be reused or repaired. Technique VII molds may be used to return an unserviceable part.

**5.4 Marking for shipment and storage.** All marking, including hazardous materials marking, shall be in accordance with MIL-STD-129, with other special markings added, as prescribed herein (see appendix A, 30.5.6).

**5.4.1 Special marking and labeling.** Marking or labeling instructions specified for opening and reusability (see 6.2) shall be provided on the container (see appendix A, 30.5.5).

**5.5 Foam workmanship.** The pack foam conforming to 4.1 and produced by the equipment specified in 4.5 shall form a unicellular plastic foam suitable for the intended techniques listed in 1.3 (see appendix A, 30.5.7).

## MIL-STD-1191

**5.5.1 Rigid foams.** The foam pack formed by a FIP technique shall be essentially homogeneous throughout with a uniform cell structure. There shall be no splits, sparklers, void openings, or pockets over 0.50 inch (1.27 cm) in any direction that might have resulted from rapid formation or release of the blowing agent before the polymer structure reached sufficient strength to contain the gas. There shall be no evidence of shrinkage such as would be apparent by wrinkles or indentations in the foam surface. Further, there shall be no unexpanded resin, occlusions, or foam scorching as evidenced by discoloration from the generation of excessive heat during the exothermic reaction. The fusion line between successive pours, unless separated by parting films, shall be well knitted and shall show no occlusions, cracks, or separations. The foam formed shall not be soft, tacky, or brittle after curing.

**5.5.2 Flexible and semirigid foams.** The foam pack formed by the FIP process shall not be soft, doughy, nonresilient, or brittle after curing. There shall be no multiple holes, voids, or "blowouts" exceeding 2 inches (5.08 cm) in diameter. Contaminated, recycled foam or more than 50 percent recycled foam shall not be integrated with the new foam pour in a completed pack. The cured foam shrinkage shall not exceed 0.5 inch (1.27 cm) from any face of container inner walls.

## MIL-STD-1191

## 6. NOTES

6.1 Intended use. This standard is intended for use whenever guidance is needed to accomplish FIP packages of the type provided for in the eight techniques described herein and when duly authorized for use by the Government. It is intended for use in conjunction with MIL-F-83671 that specifies flame-retardant polyurethane FIP materials and MIL-F-87075 that specifies applicable dispensing equipment for foam. The packs specified here-in may be fabricated by Government personnel, or the service may be acquired from contractors.

6.2 Ordering data. When acquisition documents are invoked, they should specify the following:

- a. Title, number, and date of this standard.
- b. Technique procedure (see 1.3).
- c. Issue of DODISS to be cited in the solicitation, and, if required, the specific issues of individual documents referenced (see 2.1.1, 2.2, and 20.1.1).
- d. Foam ingredients approved for the specified procedure (see 4.1.1).
- e. Electrostatic discharge sensitive items permitted (see 4.2)
- f. Heat sensitive items permitted (see 4.2).
- g. Method of preservation required (see 4.4).
- h. Minimum foam thickness requirement (see 4.7).
- i. Rough handling test requirement (see 4.7 and appendix A, 30.5.3).
- j. Complete container requirements, including specifications, classification, and dimension (see 5.1).
- k. Class and grade/category of foam material (see 5.1.1, 5.1.2, 5.1.3, 5.1.4, and 5.1.8).
- l. Width (diameter) of plastic film bag (or tube), technique IV (see 5.1.4.1).
- m. Minimum thickness (mil) of plastic sheet (see 5.1.4.1).

## MIL-STD-1191

- n. For technique V, include: (1) container specification and size; (2) foam material in accordance with MIL-F-83671; (3) re-required design steps; (4) associated wraps or other materials; (5) all figures, illustrations, and drawings necessary to fully describe the special design techniques; and (6) special markings (see 5.1.5).
- o. Complete description to include chemical class and grade, associated materials, and applicable drawings (see 5.1.6 and 5.1.7).
- p. Design procedures, technique VII (see 5.1.7.1).
- q. When containers are fabricated from material other than specified (see 5.1.7.2).
- r. Minimum clearance requirements, technique VII (see 5.1.7.2).
- s. Amount of foam required, technique VII (see 5.1.7.2).
- t. Established fragility level for shock-sensitive items (see 5.2.3).
- u. Pack conditioning requirement (see 5.2.9).
- v. Additional special marking, as required (see 5.4.1).
- w. Group B sampling and acceptance procedures and Group C quality conformance tests and examinations and all inspection requirements (see 30.4.1, 30.4.1.1, 30.4.1.3, 30.4.1.4, and 30.4.1.4.1).
- x. Container tests, as required (see 30.5.3.2).

6.3 Sampling for Group B inspection. As a guide for Group B inspection, the sampling plan in MIL-STD-105 for special inspection level S-1 may be used.

6.4 Opening and reusability information for technique VII packs. For detailed opening and reusability information on technique VII packs that expands on information in 5.1.7 and figure 13 (see DARCOMPSCC Information Pamphlet No. 0296, Procedures for Opening/ Reusing Total Encapsulated FIP Packs). Copies are available from Director, AMC Packaging, Storage, and Containerization Center, Tobyhanna, PA 18466-5097.

MIL-STD-1191

6.5 Foam-in-place training. Familiarization with basic urethane chemistry, finished foam properties, characteristics of various types of dispensing equipment, and practical exercises in forming various foam procedures are available through in-residence training courses offered by the Dean, School of Military Packaging Technology, ATTN: AMXMC-SMPT-A, Aberdeen Proving Ground, MD 21005-5001.

6.6 Subject term (key word) listing.

Encapsulated pack  
Foam-in-bag  
Flexible foam  
FIP packaging  
Inverted pack  
Preformed molds  
Rigid foam  
Semirigid foams  
Split packs  
Urethane foam

6.7 Changes from previous document. Marginal notations are not used in this standard to identify changes from the original specification document due to the extensiveness of the changes.



## MIL-STD-1191

1. Determine the static-bearing stress (pounds per square inch (psi) for each surface (weight/each surface area that will be bearing on the cushion).
2. Next, determine the item's fragility measured in g's (obtained from manufacturer or engineering estimate).
3. The thickness of foam needed may be found by looking at the cushion curves. All curves are for 30-inch drop.
4. To find foam thickness for each face of item, draw a line upward from horizontal of axis at point of static stress for that item face (1).
5. Follow a line drawn from the left (2) to a point on the vertical axis equal to the fragility estimated earlier.
6. The point (3) when these two lines cross will be near one of the cushion curves on the graph.
7. The closest cushion curve below crossing point will be the thickness of foam needed to protect face of the item in a 30-inch drop.
8. Repeat process for each of the other faces of the item. Use these values for each face or use the thickest for all faces for extra protection.

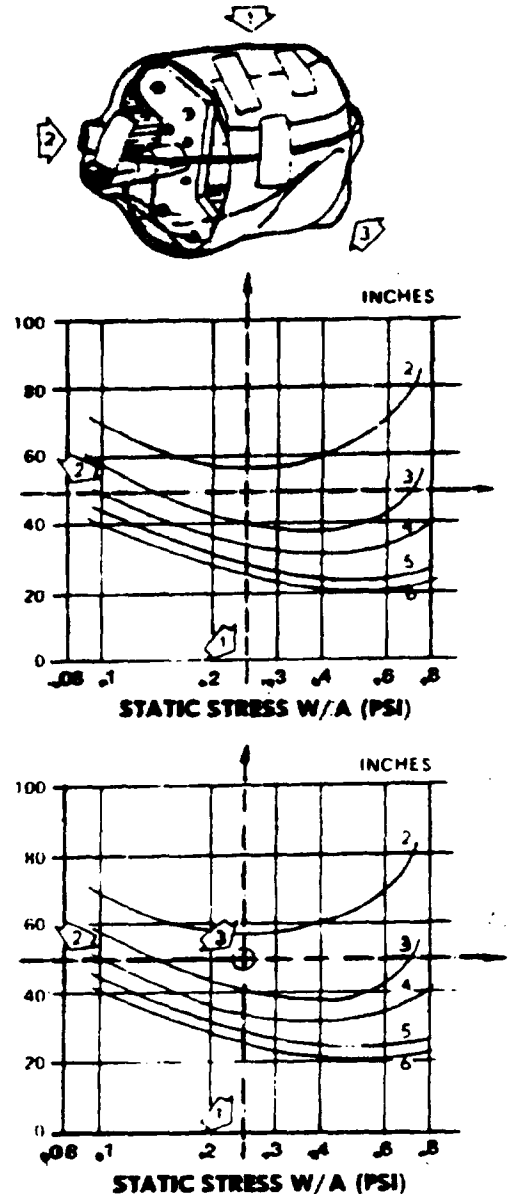

FIGURE 1. Design for flexible foam packs.

## MIL-STD-1191

9. Do not package item in flexible foam if the point where the two lines cross is below the curves.

10. The optimum loading point is indicated by the arrow. This point is defined as the lowest shock level that can be achieved using a particular 2-inch thickness cushion. Obviously then, the optimum static stress is defined by the vertical line. The problem really begins when a calculated static stress is greater than the optimum value. This could be the case in the example shown on the curve (indicated by A). In this case, item fragility was determined to be 60 g's and the calculated static stress is 0.5. If the "closest cushion curve below the crossing point" is assumed to be the 2 inch, there is a dangerous condition existing. The cushion is overloaded; such a situation allowing serious loss of thickness of the cushion and increasing shock loads during subsequent drops. Two options are available; i.e., (1) change static stress to a lower value by adding support pieces to spread the load, or (2) go to the next lower cushion curve wherein the crossing point occurs either at or to the left of the optimum point.

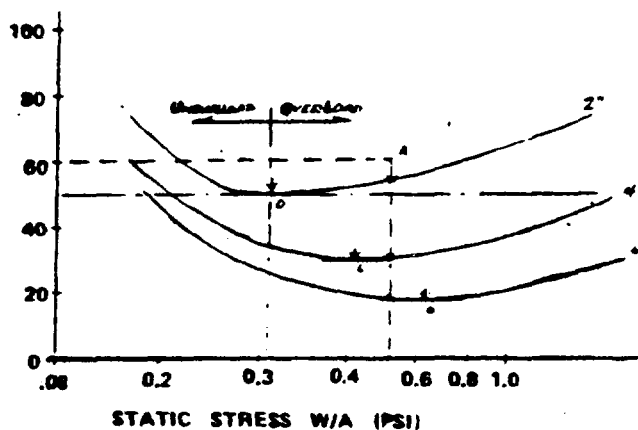
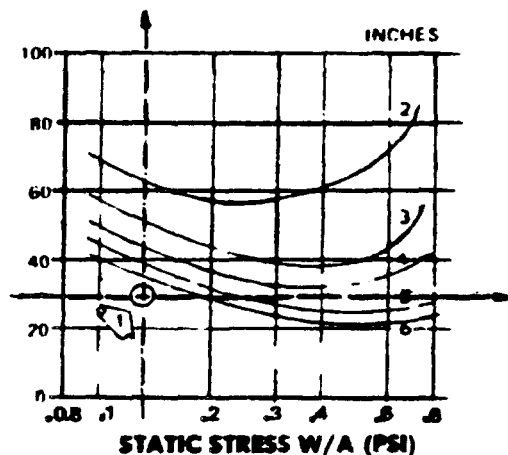

FIGURE 1. Design for flexible foam packs - Continued.

## MIL-STD-1191

2 in/5.1 cm		3 in/7.6 cm		4 in/10.2 cm	
Maximum weight <sub>1</sub> / (lb/kg)	Minimum allowable bearing surface <sub>2</sub> / (sq in/sq cm)	Maximum weight (lb/kg)	Minimum allowable bearing surface <sub>2</sub> / (sq in/sq cm)	Maximum weight (lb/kg)	Minimum allowable bearing surface <sub>2</sub> / (sq in/sq cm)
1/0.5	2.5/15	26/11.8	51/340	51/23.1	85/550
2/0.9	5.0/30	27/12.2	54/350	52/23	85/550
3/1.4	7.5/50	28/12.7	56/360	53/24.0	90/580
4/1.8	10.0/65	29/13.2	58/370	54/24.5	90/580
5/2.3	12.5/80	30/13.6	60/390	55/25.0	90/580
6/2.7	15.0/95	31/14	62/400	66/25.4	95/610
7/3.2	17.5/115	32/14.5	64/410	57/25.9	95/610
8/3.6	20.1/130	33/15.0	66/430	58/26.3	95/610
9/4.1	22.5/145	34/15.4	68/440	59/26.8	100/645
10/4.5	25.0/160	35/15.9	70/450	60/27.2	100/645
11/5.0	27.5/175	36/16.3	72/460	61/27.7	100/645
12/5.4	30.0/195	37/16.8	74/480	62/28.1	105/680
13/5.9	32.5/210	38/17.2	76/490	63/28.6	105/680
14/6.4	30.0/225	39/17.7	78/500	64/29.0	105/680
15/6.8	37.5/240	40/18.1	80/520	65/29.5	110/710
16/7.3	40.0/260	41/18.6	82/530	66/29.9	110/710
17/7.7	42.5/275	42/19.1	84/540	67/30.4	110/710
18/8.2	45.0/290	42/19.5	86/550	68/30.8	115/740
19/8.6	47.5/305	44/20.0	88/570	69/31.3	115/740
20/9.1	50.0/320	45/20.4	90/580	70/31.8	115/740
21/9.5	52.5/340	46/20.8	92/590	71/32.2	120/770
22/10.0	55.0/355	47/21.3	94/610	71/32.7	120/770
23/10.4	57.5/370	48/21.8	96/620	73/33.1	120/770
24/10.9	60.0/385	49/22.2	98/630	74/33.6	125/810
24/11.3	62.5/405	50/22.7	100/645	75/34.0	125/810

FIGURE 2. Design of 0.5 pound density semirigid foam packs.

## MIL-STD-1191

5 in/12.7 cm		6in/	
Maximum weight (lb/kg)	Minimum allowable bearing surface <sup>1/</sup> (sq in/sq cm)	Maximum weight (lb/kg)	Minimum allowable bearing surface <sup>2/</sup> (sq in/sq cm)
76/34.5	110/710	104/	130/
77/34.9	110/710	108/	140/
78/35.4	110/710	112/	140/
79/35.8	115/740	116/	150/
80/36.3	115/740	120/	150/
81/36.7	115/740	124/	160/
82/37.2	115/740	128/	160/
83/37.6	120/770	132/	170/
84/38.1	120/770	136/	170/
85/38.6	120/770	140/	180/
86/39.0	125/810	144/	180/
87/39.5	125/810	148/	190/
88/40.0	125/810	152/	190/
89/40.4	125/810	156/	200/
90/40.8	130/840	160/	200/
91/41.3	130/840	164/	210/
92/41.7	130/840	164/	210/
93/42.2	135/870	172/	220/
94/42.6	135/870	176/	220/
95/43.1	135/870	180/	230/
96/43.6	135/870	184/	230/
97/44.0	140/900	186/	240/
98/44.4	140/900	190/	240/
99/44.9	140/900	194/	240/
100/45.4	140/900	200/	260/

NOTE: If these parameters cannot be met, this foam material composition shall not be used.

1/ Item weight includes total weight ready for foaming, i.e., item plus wraps, barriers, tapes, pads, adhesives, straps, etc. When the weight falls exactly between two successive weight ranges, use the higher figure.

2/ When minimum allowable bearing surface area falls exactly between two successive figures, use next highest figure.

NOTE: When using semirigid (semiflexible) foams, bearing surfaces can be improved (increased), as necessary, by affixing them to platform, containerizing, etc., then foaming, as required.

FIGURE 2. Design of 0.5 pound density semirigid foam packs -  
Continued.

## MIL-STD-1191

1. Determine the tube/bag width by applying the following formula:

## FOR FLEXIBLE FOAM

$$\text{Tube/bag width (inches)} = \frac{M/N}{IW \times 4} + FT$$

## FOR RIGID FOAM

$$\text{Tube/bag width (inches)} = \frac{M/N}{IW \times 20} + FT$$

M = Weight of prepared item (lb)

N = Number of bags to be used

IW = Width of item (inches)

FT = Desired/required foam thickness (inches)

2. Round off the calculated tube/bag width to the nearest inch.
3. If tube/bag width is calculated to be less than 12 inches, use a 12-inch tube/bag.
4. If the calculated tube/bag width exceeds 18 inches, consider increasing the number of tubes/bags.
5. Tube/bag width may have to be recalculated for each tube/bag to provide for variations in item width.

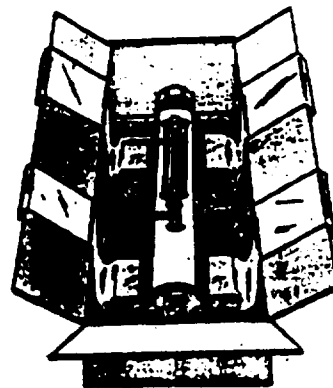
FOR RIGID FOAMS ONLY:

Bag width should at no time be less than one and one-half times the desired/required foam thickness.

If calculated tube/bag width is less than one and one-half times the foam thickness, select a wider tube/bag to meet the one and one-half minimum.

FIGURE 3. Determination of tube/bag width for technique IV.

MIL-STD-1191

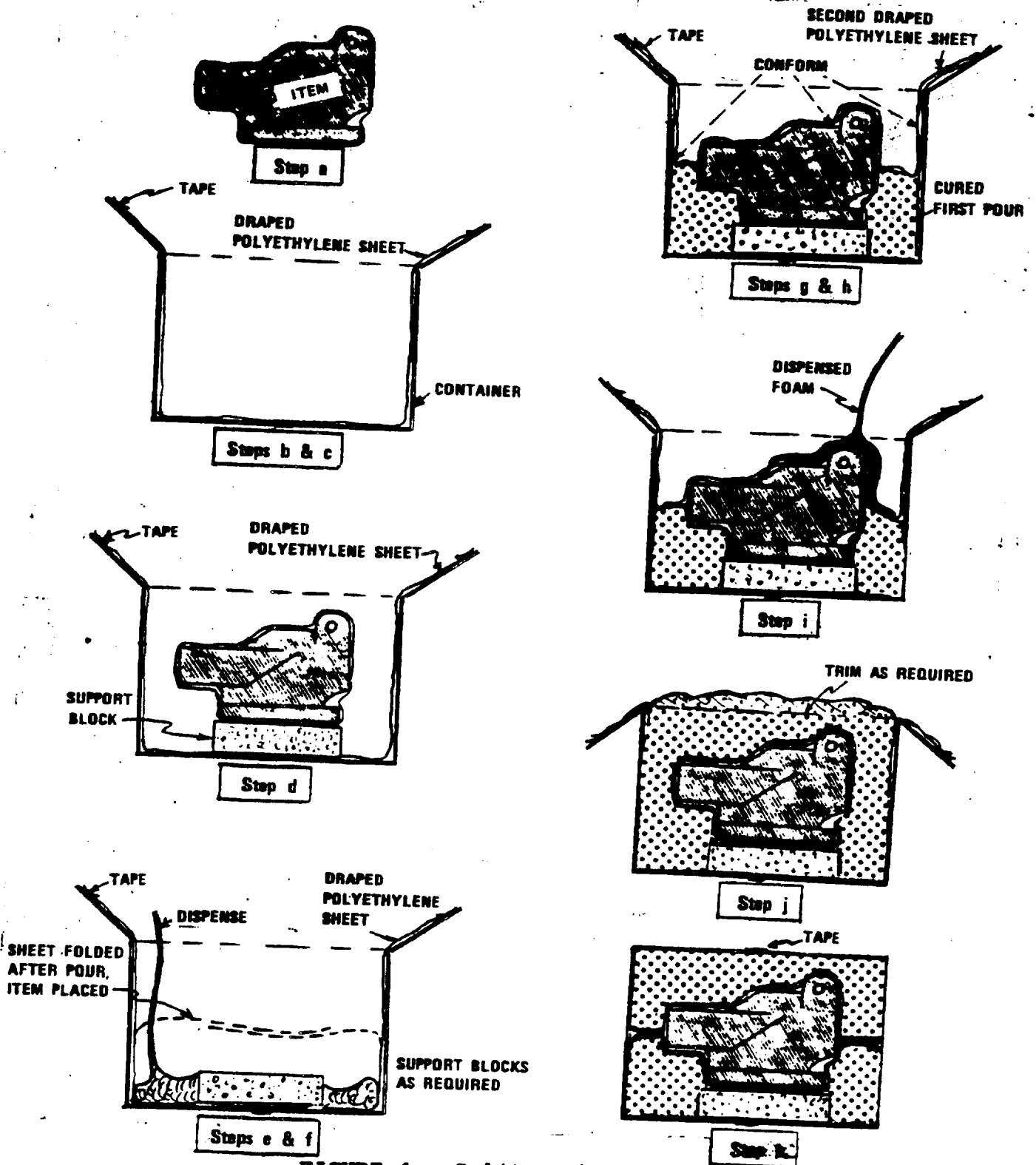

FIGURE 4. Split pack, standard.

MIL-STD-1191

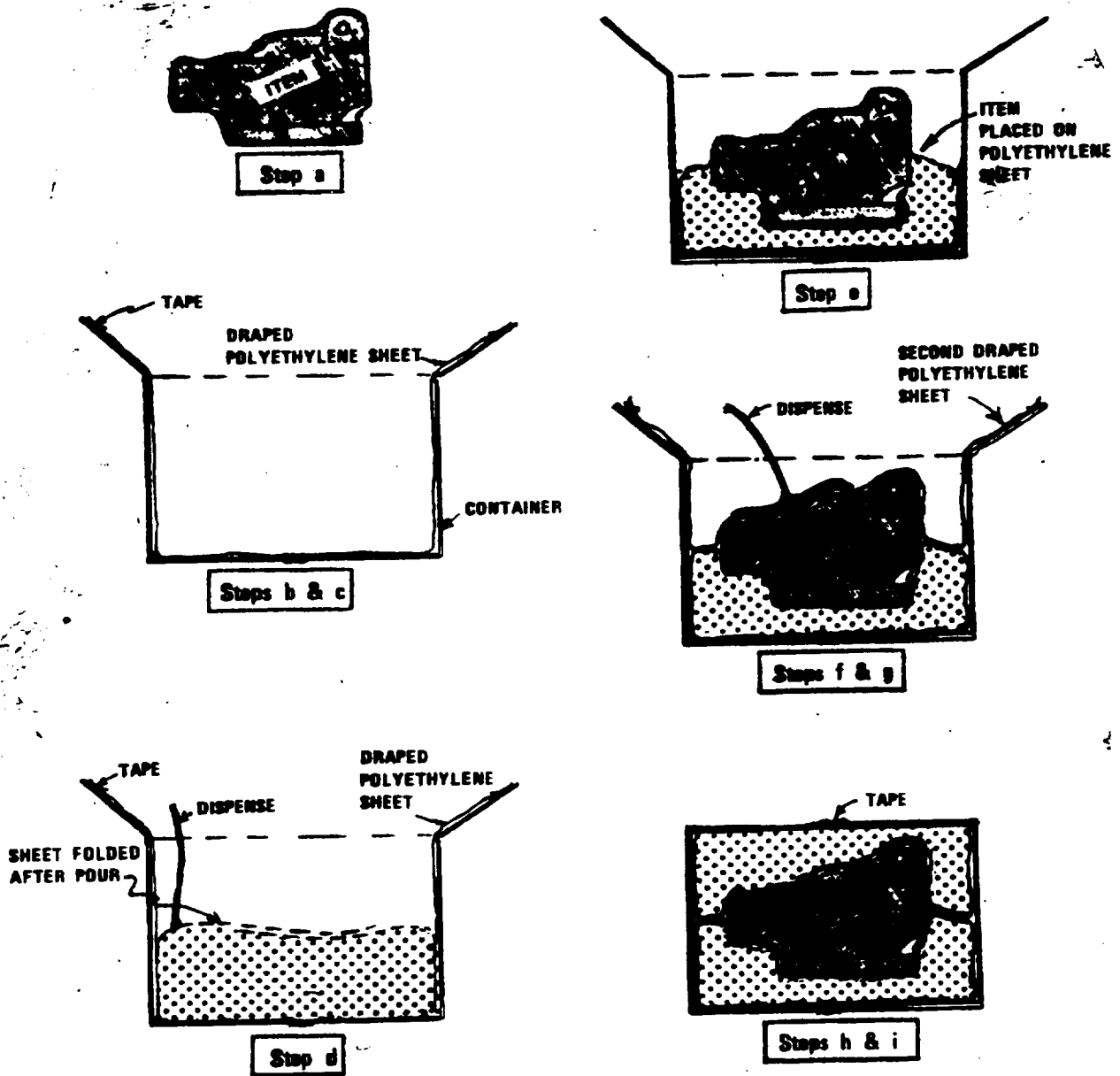

FIGURE 5. Split pack, alternate.

MIL-STD-1191

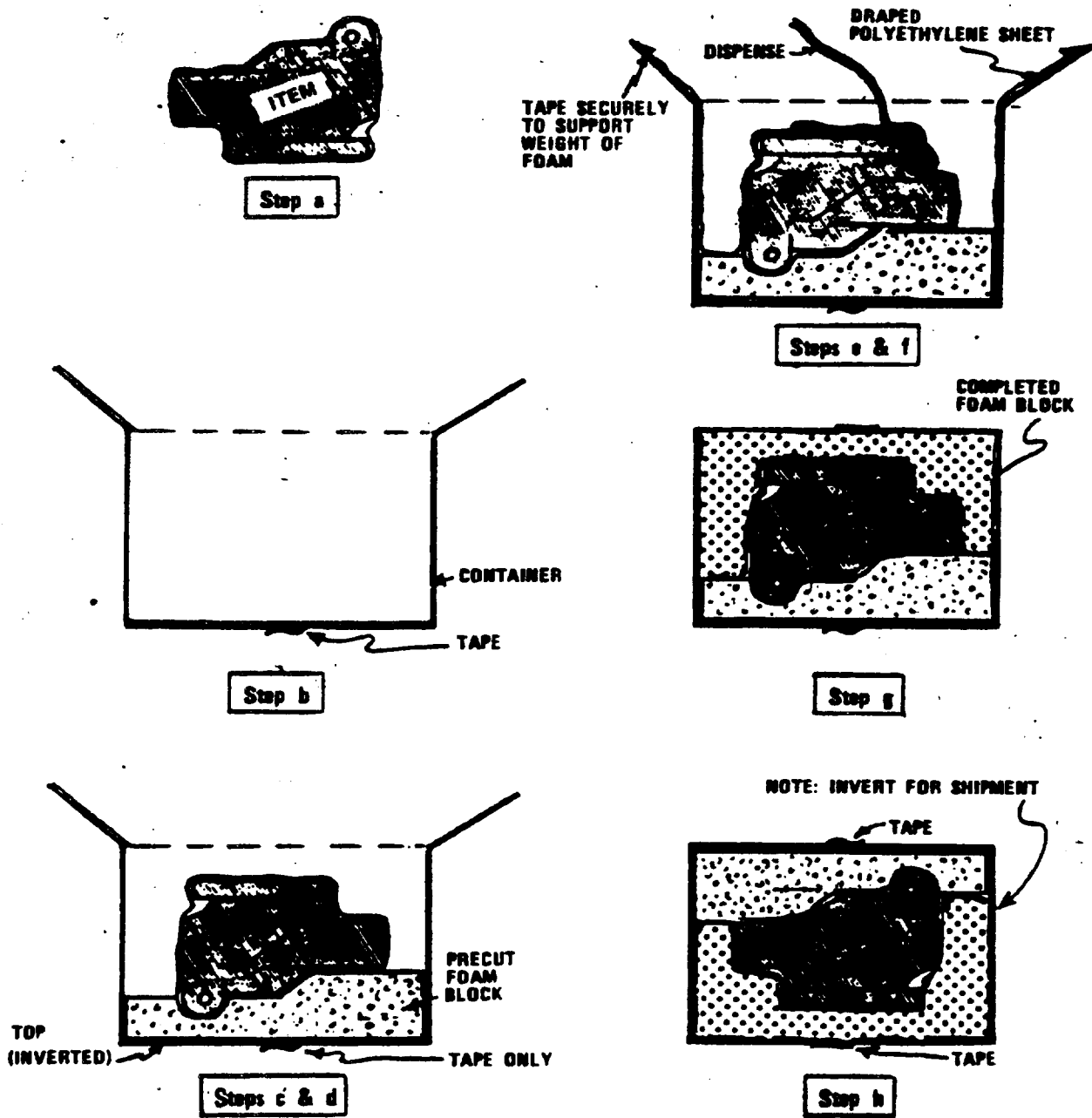

FIGURE 6. Split pack, inverted.



MIL-STD-1191

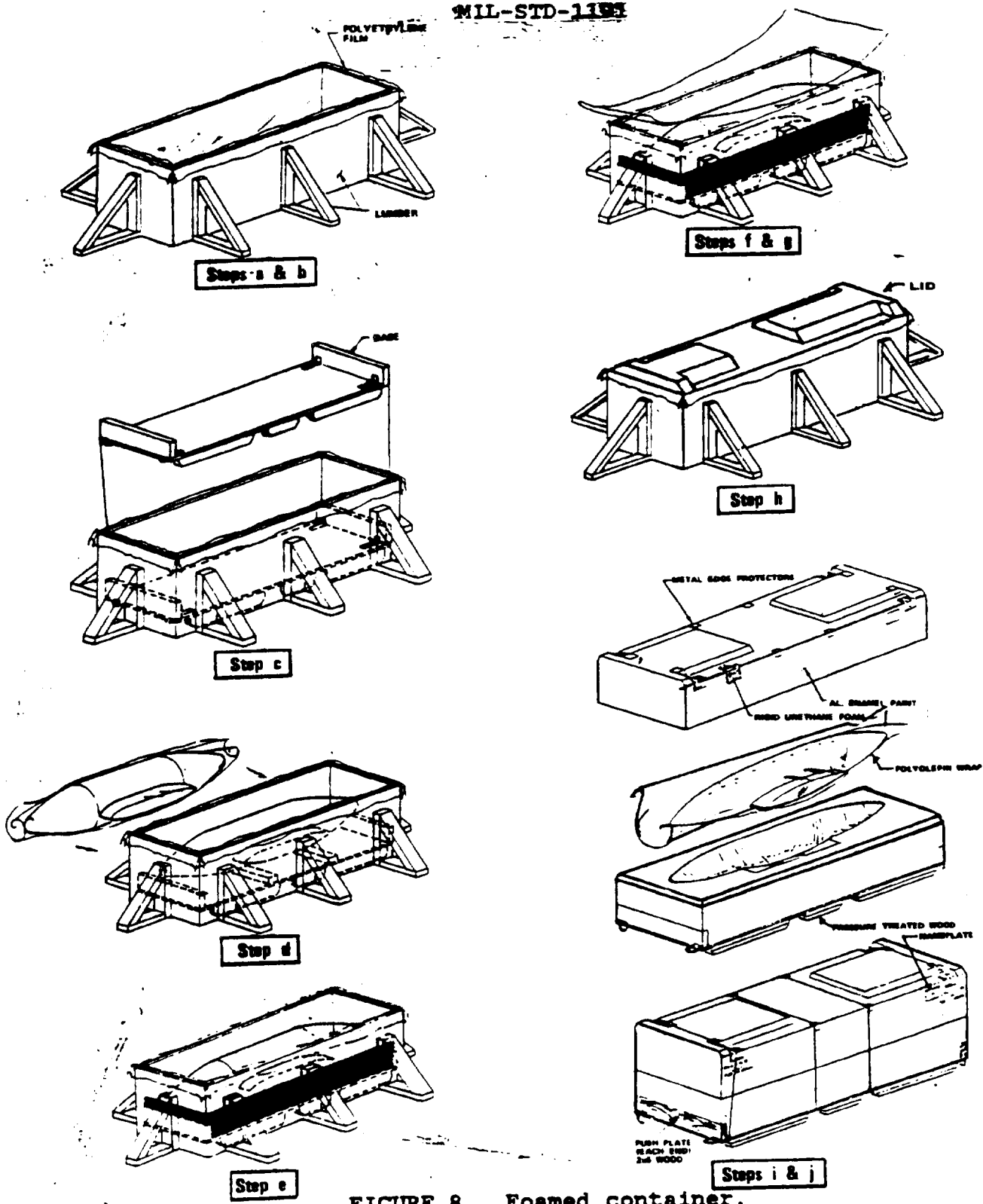
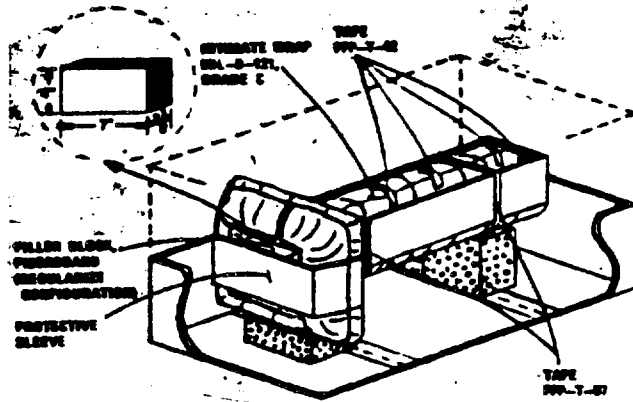
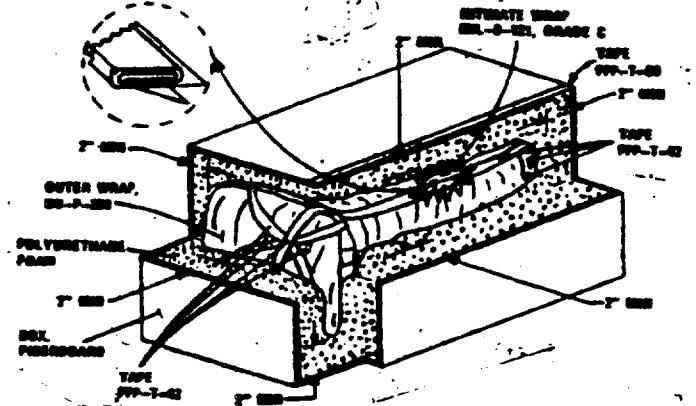

FIGURE 8. Foamed container.

MIL-STD-1191



Steps a, b, c, d, & e



Steps f, g, h, & i

FIGURE 9. Encapsulated pack (design 1).

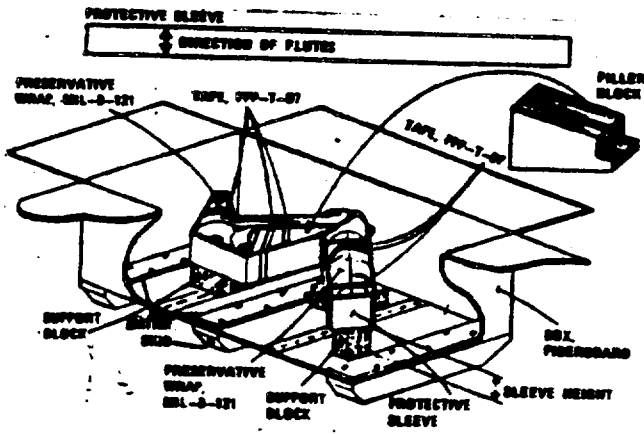

Steps a, b, c, d, & e

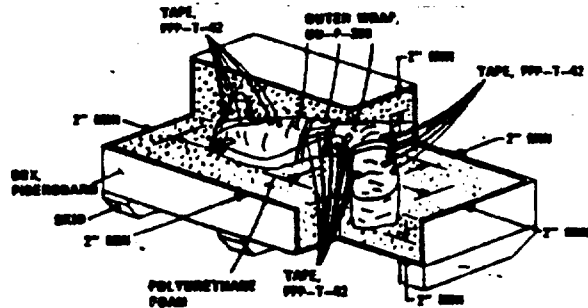

Steps f, g, h, & i

FIGURE 10. Encapsulated pack (design 2).

MIL-STD-1191

PROTECTIVE SLEEVE



CONTAINER SHELL (2 PIECE CONSTRUCTION)

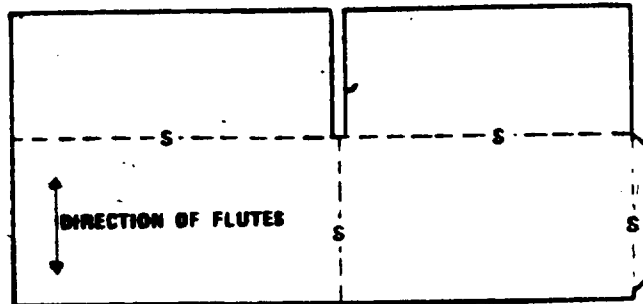

S = SCORE LINE

PRESERVATIVE WRAP, MIL-8-121

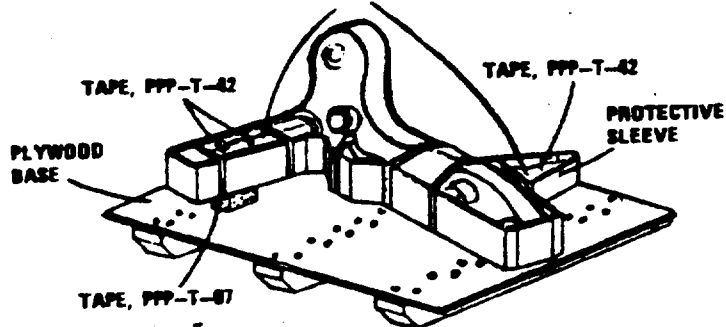

Steps a, b, c, d, & e

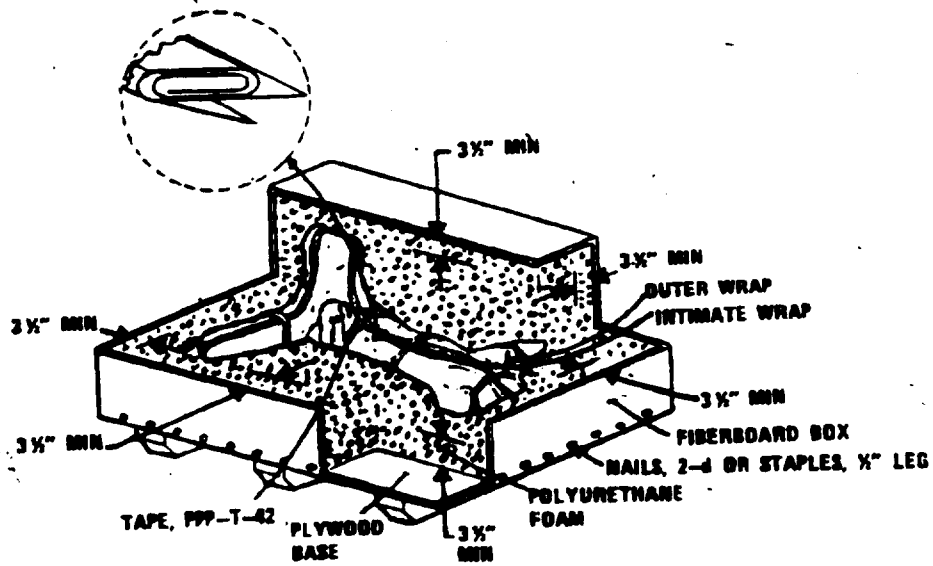

Steps f, g, h, & i

FIGURE 11. Encapsulated pack (design 3).

MIL-STD-1191

PROTECTIVE SLEEVE



CONTAINER SHELL (2 PIECE CONSTRUCTION)

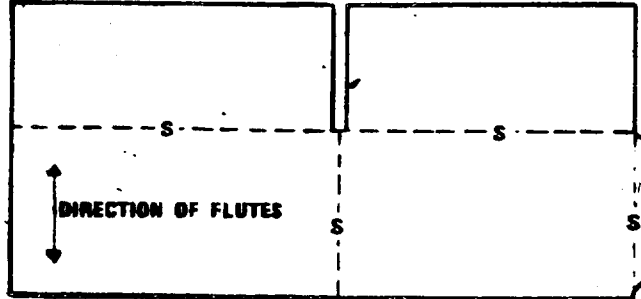

S = SCORE LINE

PRESERVATIVE WRAP, MIL-B-121

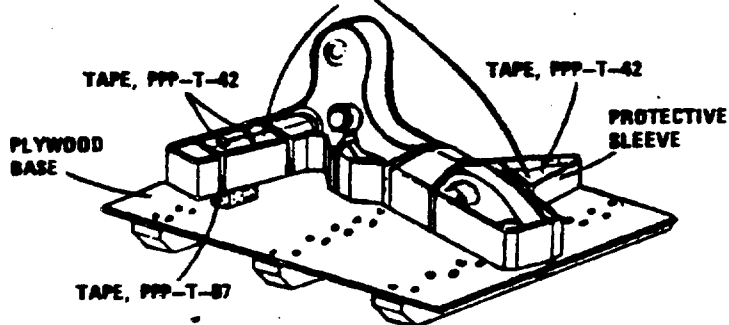

Steps a, b, c, d, & e

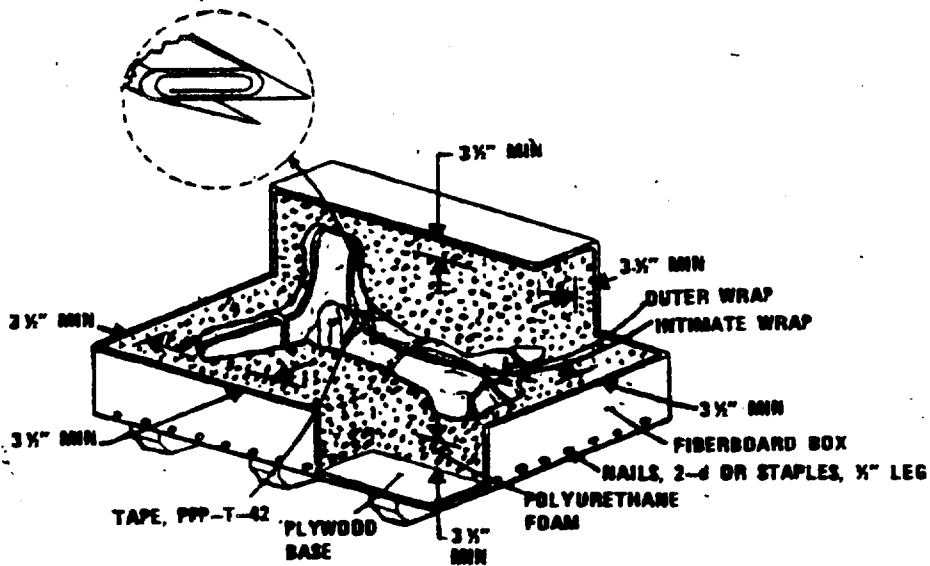

Steps f, g, h, & i

FIGURE 11. Encapsulated pack (design 3).

MIL-STD-1191

PROTECTIVE SLEEVE

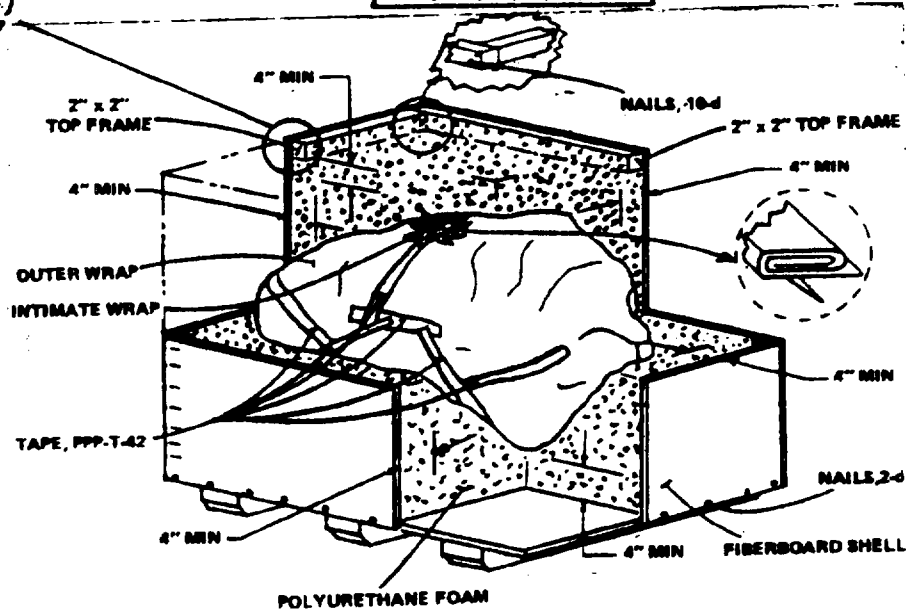
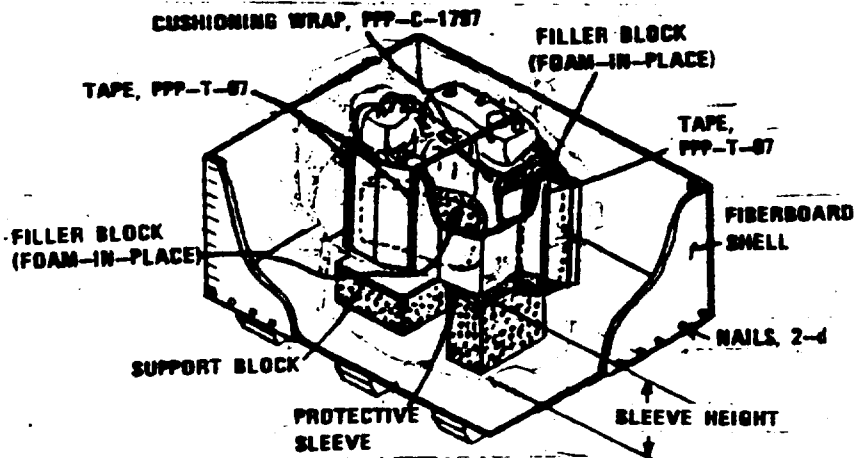
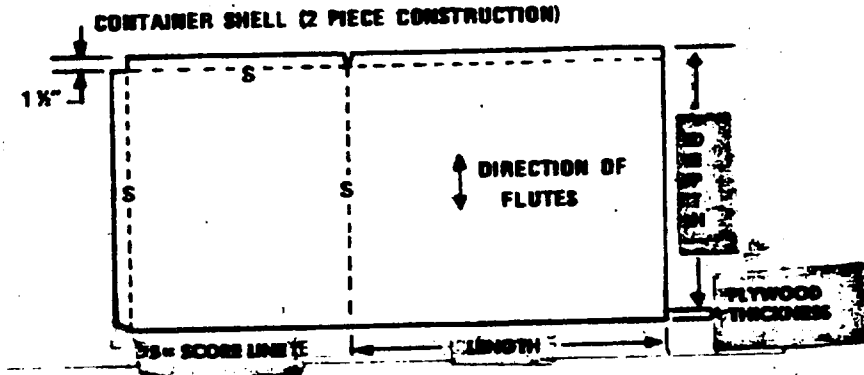
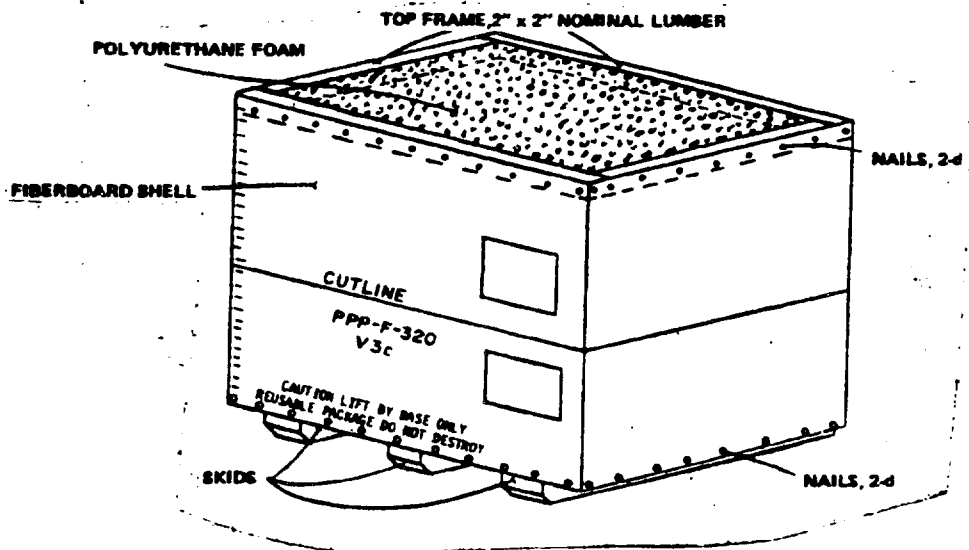
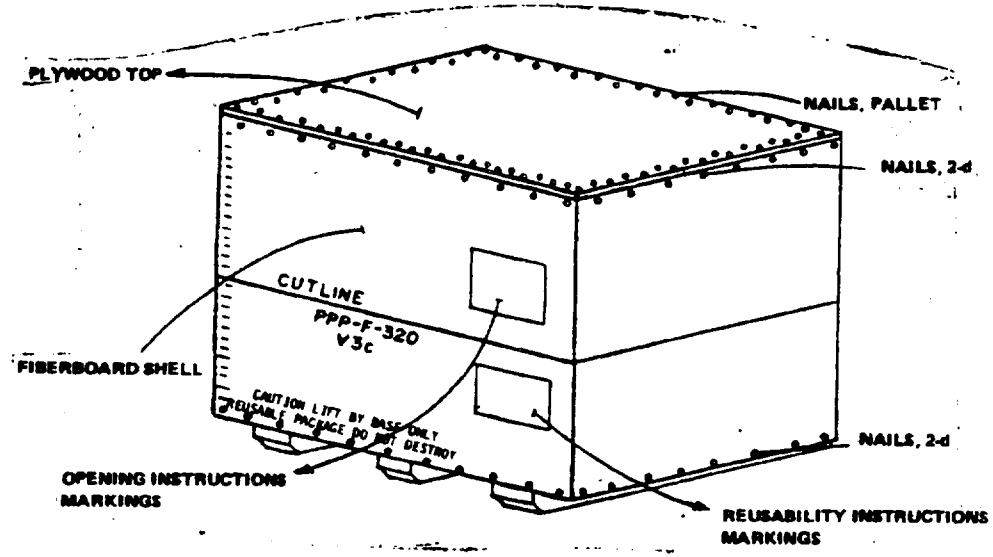

FIGURE 12. Encapsulated pack (design 4).

MIL-STD-1191



Step h



Step i

FIGURE 12 Encapsulated Pack (design 4)--Continued.

## MIL-STD-1191

**OPENING INSTRUCTIONS:**

1. CONTAINER SHALL BE OPENED BY CUTTING ALONG "CUT LINE" USING EITHER OF THE FOLLOWING METHODS:
  - A. MAKE INITIAL CUT WITH PORTABLE POWER SAW WITH BLADE SET AT 1-INCH DEPTH. CUT THROUGH THE REMAINDER OF THE POLYURETHANE FOAM WITH A HANDSAW OR LONG BLADE KNIFE.
  - B. USE A HANDSAW, PREFERABLY HSP-TYPE, MEDIUM BLADE.
2. USING EITHER METHOD, THE CUT SHALL BE CONTINUOUS AROUND THE PERIMETER OF THE CONTAINER. WHEN USING A HANDSAW, CUT THROUGH THE CONTAINER SHELL AND INTO THE FOAM USING A SERRATED SAW CUTTING TECHNIQUE UNTIL THE BLADE REACHES THE PROTECTIVE SLEEVE. (CAUTION: DO NOT JAM BLADE THROUGH SLEEVE AS ITEM MAY RECEIVE DAMAGE.)
3. AFTER CUTTING, REMOVE TOP HALF OF CONTAINER. TO FACILITATE REMOVAL, TWO PLAT STEEL SKIPS OR ANGLE IRONS 3 INCHES WIDE AND OF SUFFICIENT LENGTH TO EXTEND A MINIMUM OF 12 INCHES BEYOND THE ENDS OF THE CONTAINER SHOULD BE INSERTED INTO THE CUT ALONG THE ENDS TO EFFECT THE INITIAL SEPARATION. EXERT PRESSURE AT BOTH ENDS SIMULTANEOUSLY.
4. REMOVE THE ITEM FROM THE LOWER HALF OF THE CONTAINER EXERCISING CAUTION NOT TO FRACTURE THE FOAM.

**REUSABILITY INSTRUCTIONS:**

-ONCE OPENED, CONTAINER SHALL BE REUSED FOR SHIPMENT OF THE UNSERVICEABLE ASSET TO REPAIR OR REBUILD ACTIVITY.

1. PLACE ITEM IN CAVITY OF BOTTOM SECTION OF CONTAINER.
2. POSITION TOP SECTION OF CONTAINER OVER ITEM. (CAUTION: FILL VOID AREAS WITH CELLULOSE MADDING. IF LARGE VOIDS EXIST DUE TO FOAM REMOVAL, DO NOT REUSE.)
3. SECURE TOP TO BOTTOM BY PLACING STEEL STRAPS CONFORMING TO QQ-S-781 AROUND SIDES, TOP, AND BOTTOM OF CONTAINER. TIGHTEN STRAPS AND SECURE WITH STRAP SEALS.
4. REMOVE OR OBLITERATE OBSOLETE MARKING AND APPLY APPROPRIATE MARKING.

*Note.* Detailed opening and reusability information on technique VII packs is contained in DARCOMPSGC Information Pamphlet No. 0296, Procedures for Opening/Reusing Total Encapsulated Foam-In-Place Packs.

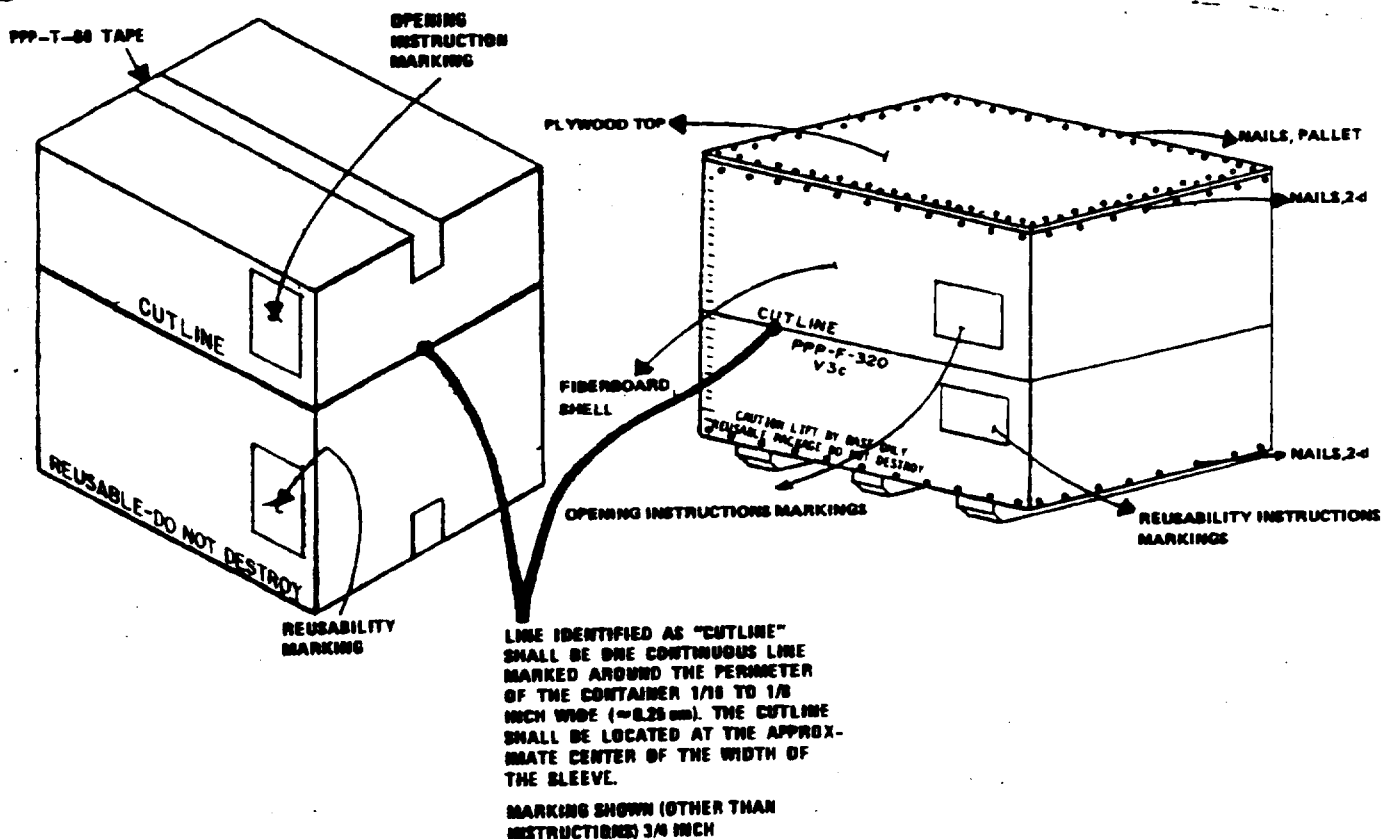

FIGURE 13. Encapsulated pack, special marking locations.

MIL-STD-1191

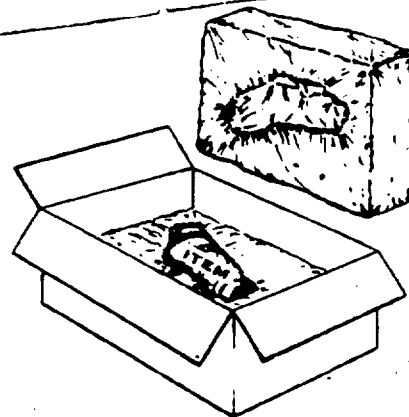
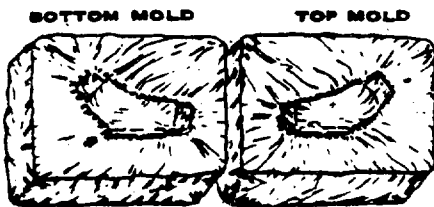
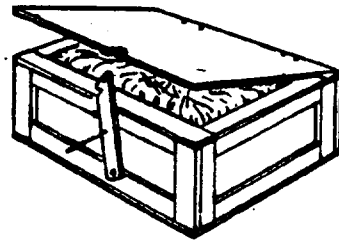
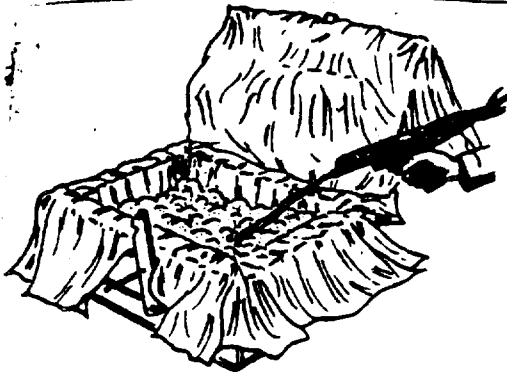
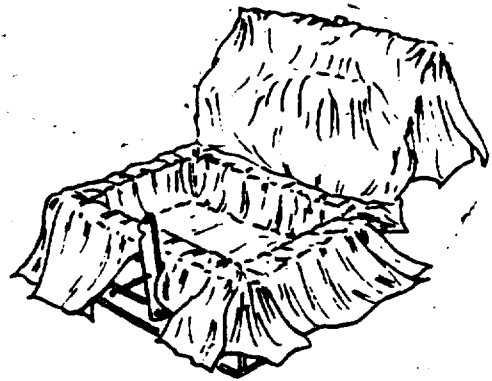
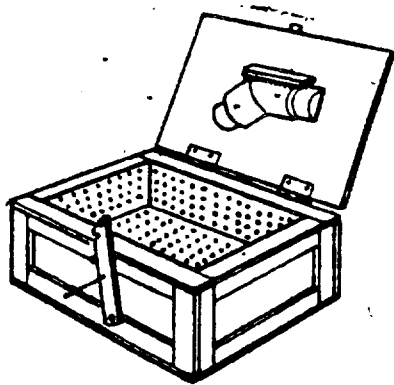

FIGURE 14. Preformed mold.



## MIL-STD-1191

## APPENDIX A

## Quality Assurance Provisions

## GENERAL

10. SCOPE. This appendix includes and classifies all inspections, examinations, and tests necessary for determining that the requirements and procedures specified in sections 4 and 5 are being adhered to properly. It provides procedural and sampling guidance for accomplishment of that compliance, assigns responsibilities for the same, and specifies quality conformance standards. This appendix is a mandatory part of the standard. The information contained herein is intended for compliance.

20. APPLICABLE DOCUMENTS.20.1 Government documents.

20.1.1 Specifications, standards, and handbooks. The following specifications, standards, and handbooks form a part of this appendix to the extent specified herein. Unless otherwise specified, the issues of these documents are those listed in the issue of the Department of Defense Index of Specifications and Standards (DODISS) and supplement thereto, cited in the solicitation (see 6.2).

## STANDARDS

## FEDERAL

FED-STD-101	- Test Procedures for Packaging Materials.
Method 5005	- Cornerwise-Drop (Rotational) Test.
Method 5007	- Free Fall Drop Test.
Method 5008	- Edgewise-Drop (Rotational) Test.
Method 5011	- Mechanical Handling Test.
Method 5012	- Pendulum-Impact Test.
Method 5019	- Vibration (Repetitive Shock) Test.
Method 5023	- Incline-Impact Test.

## MILITARY

MIL-STD-105	- Sampling Procedures and Tables for Inspection by Attributes.
-------------	--

(Unless otherwise indicated, copies of federal and military specifications, standards, and handbooks are available from Military Specifications and Standards, Bldg. 4D, 700 Robbins Avenue, Philadelphia, PA 19111-5094.)

## MIL-STD-1191

## APPENDIX A

30. QUALITY ASSURANCE PROVISIONS.

30.1 Responsibility for inspection. Unless otherwise specified in the contract or purchase order, the contractor is responsible for the performance of all inspection requirements (examinations and tests) as specified herein. Except as otherwise specified in the contract or purchase order, the contractor may use his own or any other facilities suitable for the performance of the inspection requirements specified herein, unless disapproved by the Government. The Government reserves the right to perform any of the inspections set forth in this standard where such inspections are deemed necessary to ensure supplies and services conform to prescribed requirements.

30.1.1 Responsibility for compliance. All items shall meet all requirements of sections 4 and 5. The inspection set forth in this standard shall become a part of the contractor's overall inspection system or quality program. The absence of any inspection requirements in the standard shall not relieve the contractor of the responsibility of ensuring that all products or supplies submitted to the Government for acceptance comply with all requirements of the contract. Sampling inspection, as part of manufacturing or service operation, is an acceptable practice to ascertain conformance to requirements. However, this does not authorize submission of known defective material, either indicated or actual, nor does it commit the Government to accept defective material.

30.1.2 Alternate test procedure approval. In instances where a test may necessitate an impractical manipulation of a mounted item, where the overall size or weight of the item or test equipment availability obviates compliance with a specific test requirement of this specification, the contractor may submit a request accompanied by detailed justification through the cognizant Government inspector for approval of an alternate test procedure.

30.2 Classification of inspections. The inspections specified herein are classified as quality conformance inspections (see 30.4).

30.3 Inspection conditions. All inspections shall be performed under ambient environmental conditions of temperature and relative humidity. Best results are obtained when tested in a temperature range between 68° F. (20° C.) and 85° F. (29° C.) with a relative humidity of 40 to 60 percent. Regardless of the procedures being used, no foam packs shall be either examined or tested prior to 24 hours after final pouring of the polyurethane ingredients.

## MIL-STD-1191

## APPENDIX A

30.4 Quality conformance inspection.

30.4.1 Inspection of product for delivery. Inspection of product for delivery shall consist of group A, B, and C inspections. Sequence of inspections shall be exactly as specified herein. This will insure that procedural steps have been followed correctly and end-product foam characteristics achieved without adverse effects on items, other protective packaging materials, or containers (see 6.2).

30.4.1.1 Inspection lot. An inspection lot shall consist of all foam packs of the same technique produced under essentially the same conditions and offered for inspection at one time (see 6.2).

30.4.1.2 Group A inspection. Group A inspection shall consist of certification supported by verifying data specified in table I in the order shown. Sampling and acceptance procedures shall be as specified in MIL-P-116.

30.4.1.3 Group B inspection. Group B inspection shall consist of the examinations and tests specified in table I in the order shown. Selection and use of sampling and acceptance procedures shall be specified in the contract or order (see 6.2). Guidance for those procedures for group B inspection is given in 6.3.

30.4.1.3.1 Disposition of sample units. Sample units that have been subjected to group B inspection shall not be delivered on the contract or purchase order.

30.4.1.4 Group C inspection. Group C inspection shall consist of the examinations and tests specified in table I, as required, for the procedure and foam formulation used.

30.4.1.4.1 Sampling plan. When group C tests are specified in the contract or order for quality conformance inspection, samples shall be selected at random and subjected to group C tests. Sampling and acceptance procedures shall be specified in the contract or order (see 6.2).

30.4.1.5 Rejected lots. If an inspection lot is rejected, the supplier may rework it to correct the defects or screen out the defective units and resubmit for reinspection. Resubmitted lots shall be inspected using tightened inspection in accordance with MIL-STD-105. Such lots shall be separate from new lots and shall be clearly identified as reinspected lots. With technique VII, the entire lot is not rejected if a single failure occurs.

## MIL-STD-1191

## APPENDIX A

Instead, the next five packs produced after the failure shall be examined. If failure repeats in any of these packs, the entire lot shall be rejected. Also, for technique VII, only every fourth lot shall be examined. Acceptance of the inspected lots presumes acceptance of the lots between them. For example, if lots 4 and 7 are accepted, then lots 5 and 6 are also accepted.

### 30.5 Methods of inspection.

30.5.1 Examinations of packs. Group A examinations shall be affirmed by certification from the contractor. Group B examinations shall be visual inspections or tests, as required. Failure to comply with all of the visual examinations and test certification requirements shall be cause for rejection (table I).

30.5.2 Inspection for surface distortion. Packages shall be inspected for surface distortion characterized by split closure tape, bulging container walls, or container concavity. The degree of surface distortion shall be determined using a straight edge of appropriate length for the particular dimensions of the pack. All surfaces, excluding bottom surfaces where skids are attached, shall be checked for measurable distortion, as determined by placing the straight edge along the diagonal of each surface (see 5.2.1).

TABLE I. Test required for the procedure and foam formulation utilized.

GROUP A (examinations)	Require para
-Designated packaging materials and FIP ingredients used in the fabrication of the foam pack.	4.1 thru 4.1.3
-Required foaming equipment and supplies selected for development of foam pack.	4.5
-Preparation for developing foam packs--acceptable.	4.6 thru 4.8
-Foaming technique followed for the applicable procedure.	5.1
-Opening method suitably described on pack exterior.	5.1
-Environmental considerations pertinent to conditions affecting operating personnel, ecology, and waste management--acceptable.	4.3

## MIL-STD-1191

## APPENDIX A

TABLE I. Test required for the procedure and foam formulation utilized - Continued.

GROUP B	Require para	Test para
-Reliability of opening method.	5.2.4	30.5.5
-Completeness of void fill, as required.	5.2.5	30.5.5
-No evidence of foam breakthrough and undesirable adherence.	5.2.6	30.5.5
-Complete release of item from foam pack.	5.2.7	30.5.5
-No evidence of item damage, foam particles, static charges, or unsafe humidity indicators.	5.2.8	30.5.5
-Reusability.	5.3	30.5.8
-Marking and labeling of foam packs properly applied.	5.4	30.5.6
-Foam workmanship.	5.5	30.5.7
GROUP C	Require para	Test para
-Surface distortion.	5.2.1	30.5.2
-Rough handling test.	5.2.2	30.5.3
-Shock mitigation (flexible foams).	5.2.3	30.5.4

30.5.3 Rough handling test. Packs shall be subjected to the following sequence of rough handling tests in accordance with the applicable methods of FED-STD-101.

30.5.3.1 Small containers test. Those having no edge or diameter over 60 inches (152.40 cm) and a gross weight of 150 pounds (68.10 kg) or less. Any container with skids shall be tested as a large container.

Drop test (free fall), Method 5007, procedure B.  
Drop test (free fall), Method 5007, procedure E.

30.5.3.2 Tests for large containers and all others.

Cornerwise Drop (Rotational) Test, Method 5005.

Edgewise Drop (Rotational) Test, Method 5008.

Vibration (Repetitive Shock) Test, Method 5019 (when specified, see 6.2).

Incline-Impact Test, Method 5023 (when specified, see 6.2).

Pendulum-Impact Test, Method 5012, as applicable.

## MIL-STD-1191

## APPENDIX A

Graduated drop and impact test heights and number of impacts shall be in accordance with table IV of MIL-P-116, as determined by the gross weight of the container and contents. Following the performance of these tests, exterior surfaces of the pack shall be inspected for evidence of container shell, base, and top frame separation from the polyurethane foam for those procedures not using intentional parting-type materials. Evidence of this separation shall be cause for rejection of the pack. Determination of conformance to the item looseness will be made following opening. Evidence of item movement in any direction; crushing of foam materials; item rotation from original placement; or item damage such as broken or distorted projections, loosened mountings, broken wires, or scorched surfaces shall be cause for rejection.

**30.5.4 Examination for shock mitigation (flexible foams).** Packs shall be opened and examined initially for conformance to 5.2.4 through 5.2.9 and the test specified in 30.5.5. Prior to determining reusability, the item shall be removed, as necessary, to permit attachment of appropriate accelerometers. Three accelerometers, one for each major axis or a single triaxial unit, shall then be mounted on the item, or simulated item, as close to the center of gravity as possible, in such a manner to insure against improper movement during subsequent shock tests. Cable leads shall then be attached to the sensors and the pack reclosed. During the reclosure, the pack shall be examined for conformance with the requirement in 5.5 and the test specified in 30.5.7. Access through the container wall shall be accomplished for extending the sensor cable leads to the instrumentation. Readout provisions shall consist of necessary measuring instruments to include any calibration reference, amplifiers, or recorders that will insure an accuracy of +5 percent in the readings obtained. Free fall, flat drop tests shall be performed initially at ambient temperatures in accordance with procedure B of Method 5007, FED-STD-101, using the graduated drop heights of table I of that standard for level A requirements. A series of six drops shall be made on each flat surface of the container with only the final five drops being recorded. From the readings taken for each drop, the resultant "g's" shall be determined for that drop. The average of the five resultant shocks shall be compared with the required "g" protection. A higher "g" figure than that allowed shall be cause for rejection of the pack. The identical pack shall be conditioned for 24 hours at a temperature of -20° F. (-29° C.) (see 5.2.9). Immediately following conditioning of the pack, two additional drops shall be performed using the same procedure as used at ambient temperatures. Resultant "g's", as determined by the second drop, shall not exceed the specified fragility level. Failure shall be cause for rejection of the pack (see 5.2.3).

## MIL-STD-1191

## APPENDIX A

**30.5.5 Opening test.** All techniques of FIP packs shall be opened in accordance with instructions provided on the pack exterior (see 5.4.1) or for those packs in which opening is obvious. For purposes of this test, opening shall include those operations required to provide access to the prepared item and those visual examinations necessary to confirm the acceptability of the procedure (see 5.2.5 through 5.2.8). The interior of the pack shall then be examined for degree of void fill, improper foam adherence or loose particles (breakthrough), difficult item removal (locking or sealing), humidity indicator in a safe condition, and suspected damage to items. A minimum of 95 percent fill of the intended void space shall exist. Where the specified procedure permits, the foam exterior surfaces shall be examined for void areas (see 5.2.5).

**30.5.6 Marking and labeling examination.** Visual examination of the exterior of the completed package shall verify the proper application of any marking and labeling, as specified (see 5.4).

**30.5.7 Foam workmanship examination.** The FIP packs shall be examined for evidence of splits, sparklers, shrinkage, voids, irregularities, or striations in the foam (caused by incomplete foam mix). Sample blocks shall be cut from the foam pack(s) and trimmed to provide plane and parallel surfaces to a size of 4 inches (10.16 cm), by 4 inches (10.16 cm) by 2 inches (5.08 cm). The thickness dimension shall be perpendicular to the direction of rise. One specimen shall be taken from each of two opposite sides. For purpose of this test, halves formed constitute a single block. When two or more successive pours (as opposed to a single, continuous one) are made thereby creating a fusion line where the pours meet, then, the sample specimen shall be cut so that the fusion line is included across the specimen as near to its center or midpoint as possible. This will allow for examination of the quality of the "knit" of these pours. The examined specimens shall be free of soft or tacky particles (unexpanded resin) or show evidence of splits, sparklers, or shrinkage. Further, there shall be no void openings or pockets (blow holes) exceeding 0.5 inch in any direction or evidence of scorching during foam formation. Packs utilizing reused foam shall be examined for incomplete bonding of refoamed materials caused by using excessive amounts of previously foamed materials without enough virgin foam around these materials to provide a complete bond (see 5.5). If examination reveals any of the aforementioned characteristics, it shall be cause for rejection.

**30.5.8 Reusability.** Formed foam mold packs shall be tested to ensure that, once opened as in 30.5.5, the molds formed allow ready replacement of the prepared item and reuse of the pack. Failure to accomplish these requirements shall be cause for rejection (see 5.3). This applies to packs other than technique VII packs. Technique VII opened for quality conformance inspection shall not be reused or repaired except for return of an unserviceable part (see 5.1.7.4, 5.2.4, and 5.3).

## MIL-STD-1191

## APPENDIX B

## ENGLISH-METRIC CONVERSIONS

**10 SCOPE.** This appendix gives the necessary metric conversion for each English equivalent used throughout this standard. This is in addition to equivalents already given parenthetically within the preceding section. Standard measurement equivalents and supplemental equivalents are given here also to assist in converting any computations that result from the various formulas that are employed herein. This appendix, then, is not mandatory but included for guidance only.

TABLE II. Standard English-metric equivalentsVolume:

1 fluid ounce	=	29.57 milliliters
1 pint	=	0.47 liter
1 quart	=	0.95 liter
1 gallon	=	3.79 liters
1 cubic foot	=	0.03 cubic meter

NOTE. To change cubic inches to cubic feet, divide by 1728.

Weight:

1 ounce (avoirdupois)	=	28.35 grams
1 pound (avoirdupois)	=	453.59 grams, 0.454 kilogram
2.2 pounds	=	1.00 kilogram

Length:

1 inch	=	2.54 centimeters, 25.4 millimeters
1 foot	=	30.48 centimeters, 0.305 meter
39.37 inches	=	1.00 meter
3.28 feet	=	1.00 meter
25.00 feet	=	7.625 meters
50.00 feet	=	15.25 meters

NOTE. 10 millimeters equals 1 centimeter.



## MIL-STD-1191

## APPENDIX B

TABLE III. MIL-STD-1191 English-metric conversionsTemperature conversion:

To change degrees Celsius (C.) to degrees Fahrenheit (F.), multiply temperature by 1.8 and add 32 degrees F.

To change degrees Fahrenheit (F.) to degrees Celsius (C.), subtract 32 from the temperature and divide by 1.8.

Degrees Fahrenheit = Degrees Celsius

-20	-29
0	-18
32	0
60	16
68	20
85	29
100	38
125	52
150	66
212	100

Volume (Liquids):Gallons = Liters

1	3.79
5	18.95
50	189.5
55	208.45

Weight:Ounces = Grams

1	28.35
10	283.5

(1000 grams = 1 kilogram)

Volume (Solids):Cubic feet = Cubic meter

1.0	0.03
1.2	0.036
1.3	0.039
2.0	0.06
2.5	0.075
3.0	0.09
4.1	0.123
4.7	0.141
5.3	0.16

Cubic feet = Cubic meters

6.0	0.18
6.5	0.195
8.4	0.25
9.0	0.27
10.0	0.30
12.0	0.36
30.0	0.90
60.0	1.80
66.5	1.995

## MIL-STD-1191

## APPENDIX B

TABLE III. MIL-STD-1191 English-metric conversions - Continued.

<u>Pounds</u>	=	<u>Kilograms</u>	<u>Pounds</u>	=	<u>Kilograms</u>
.5		0.23	100		45.4
1		0.45	125		56.75
2.2		1.0	144		65.37
10		4.54	150		68.10
11		4.99	200		90.80
40		18.16	250		113.50
50		22.7	400		181.6
52		23.61	500		227.0
65		29.51	1000		454.0
75		34.05	1700		771.8

<u>Inches</u>	=	<u>Centimeters</u>	<u>Inches</u>	=	<u>Centimeters</u>
0.025		0.06	2.75		6.99
0.030		0.08	3.0		7.62
0.035		0.09	4.0		10.16
0.042		0.11	5.0		12.70
0.063 (1/16)		0.16	6.0		15.24
0.125 (1/8)		0.32	7.0		17.78
0.188 (3/16)		0.48	8.0		20.32
0.25 (1/4)		0.64	9.0		22.86
0.375 (3/8)		0.95	10.0		25.40
0.50 (1/2)		1.27	12.0		30.48
0.625 (5/8)		1.59	14.875		37.79
0.75 (3/4)		1.91	18.0		45.72
0.875 (7/8)		2.22	20.0		50.80
1.0		2.54	26.875		69.53
1.25		3.18	30.0		76.20
1.5		3.81	32.0		81.28
2.0		5.08	40.0		101.60
2.5		6.35	45.5		115.57
			50.0		127.00
			53.0		134.62
			60.0		152.40
			80.0		203.20

**MIL-STD-1191**

**CONCLUDING MATERIAL**

**Custodians:**

Army - SM  
Navy - SA  
Air Force - 69  
DLA-DH

**Preparing activity:**

Army - SM  
(Project PACK 0927)

**Review activities:**

Army - AT, EA, MD, AL, ME, AR  
Navy - AS, OS  
Air Force - 11, 43, 70, 71, 79, 80, 84, 99  
DLA - CS, ES

**User activities:**

Army - MR, MT  
Navy - EC, MC, SH, YD

**INSTRUCTIONS:** In a continuing effort to make our standardization documents better, the DoD provides this form for use in submitting comments and suggestions for improvements. All users of military standardization documents are invited to provide suggestions. This form may be detached, folded along the lines indicated, taped along the loose edge (*DO NOT STAPLE*), and mailed. In block 5, be as specific as possible about particular problem areas such as wording which required interpretation, was too rigid, restrictive, loose, ambiguous, or was incompatible, and give proposed wording changes which would alleviate the problems. Enter in block 6 any remarks not related to a specific paragraph of the document. If block 7 is filled out, an acknowledgement will be mailed to you within 30 days to let you know that your comments were received and are being considered.

**NOTE:** This form may not be used to request copies of documents, nor to request waivers, deviations, or clarification of specification requirements on current contracts. Comments submitted on this form do not constitute or imply authorization to waive any portion of the referenced document(s) or to amend contractual requirements.

(Fold along this line)

(Fold along this line)

DEPARTMENT OF THE ARMY



NO POSTAGE  
NECESSARY  
IF MAILED  
IN THE  
UNITED STATES

OFFICIAL BUSINESS  
PENALTY FOR PRIVATE USE \$300

**BUSINESS REPLY MAIL**  
FIRST CLASS PERMIT NO. 12062 WASHINGTON D. C.  
POSTAGE WILL BE PAID BY THE DEPARTMENT OF THE ARMY

DIRECTOR  
AMC PACKAGING, STORAGE,  
AND CONTAINERIZATION CENTER  
ATTN SDSTO-TE-S  
TOBYHANNA PA 18466-5097

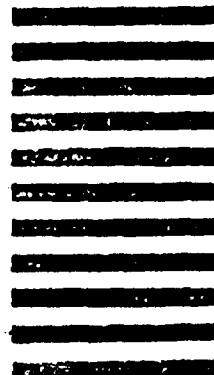

## STANDARDIZATION DOCUMENT IMPROVEMENT PROPOSAL

*(See Instructions - Reverse Side)*

1. DOCUMENT NUMBER MIL-STD-1191		2. DOCUMENT TITLE Foam-In-Place Packaging, Procedures For	
3a. NAME OF SUBMITTING ORGANIZATION		4. TYPE OF ORGANIZATION (Mark one)	
3b. ADDRESS (Street, City, State, ZIP Code)		<input type="checkbox"/> VENDOR	
		<input type="checkbox"/> USER	
		<input type="checkbox"/> MANUFACTURER	
		<input type="checkbox"/> OTHER (Specify): _____	
3. PROBLEM AREAS			
a. Paragraph Number and Wording:			
b. Recommended Wording:			
c. Reason/Rationale for Recommendation:			
6. REMARKS			
7a. NAME OF SUBMITTER (Last, First, MI) - Optional		b. WORK TELEPHONE NUMBER (Include Area Code) - Optional	
8. MAILING ADDRESS (Street, City, State, ZIP Code) - Optional		9. DATE OF SUBMISSION (YYMMDD)	

69540.NC1

CK