

MIL-STD-1187
13 February 1976

Superseding
MIL-HDBK-769 (SM)
16 December 1974

MILITARY STANDARD

**STANDARD SIZE UNIT, INTERMEDIATE
AND EXTERIOR CONTAINERS FOR
MODULAR PACKAGING AND UNITIZATION
ON THE 40" × 48" PALLET**



FSC PACK

MIL-STD-1187
13 February 1976

DEPARTMENT OF DEFENSE
WASHINGTON, DC 20301

**Standard Size Unit, Intermediate
and Exterior Containers for
Modular Packaging and Unitization
on the 40" x 48" Pallet**

MIL-STD-1187

- 1. This Military Standard is approved for use by all Departments and Agencies of the Department of Defense.**
- 2. Recommended corrections, additions, or deletions should be addressed to Commander, Tobyhanna Army Depot, ATTN: DRXTO-TP, Tobyhanna, PA 18466.**

FOREWORD

Today's standard practice of designing a tailor-made package with a minimum of packaging materials to conserve weight and cube has become too costly because of high labor costs. Packaging functions account for about 25 percent of the direct costs incurred in supply depot operations within the Department of Defense (DOD).

One answer to these costs is an automatic system of packaging that is equipment oriented rather than labor oriented. The state-of-the-art is such that machines are capable of effecting significant labor savings while simultaneously providing superior packaging in terms of item protection. Too, the vast majority of the DOD item stockage lends itself, in terms of size and weight, to an automatic system. One of the first steps toward mechanization of the packaging function is the development of the standard size modular containers.

This document provides basic and fundamental information on a family of standard size unit, intermediate and exterior containers for use in modular packaging. The exterior containers are of such dimensions as to form unit loads on pallets without overhang and voids and provide maximum cube utilization when containerized in MILVAN's, SEAVAN's and all commercial intermodal transportation systems.

MIL-STD-1187
13 February 1976

CONTENTS

Paragraph		Page
	PROMULGATION SHEET	ii
	FOREWORD	iii
1.	SCOPE	1
1.1	Scope	1
1.2	Applicability	1
2.	REFERENCED DOCUMENTS	1
3.	GENERAL REQUIREMENTS	2

TABLES

- I PPP-B-601 (Boxes, Wood, Cleated-Plywood) --type-overseas, styles A, B, and I
- II PPP-B-621 (Boxes, Wood, Nailed and Lock Corner) --class 2, overseas, styles 2 through 4½
- III PPP-B-585 (Boxes, Wood, Wirebound) --class 3, military overseas
- IV PPP-B-640 (Boxes, Fiberboard Corrugated Triple-wall) --class 2, weather-resistant, style E, RSC
- V PPP-B-636 (Boxes, Shipping, Fiberboard) --type CF, class domestic and class weather-resistant, variety double-wall, style RSC
- VI PPP-B-636 (Boxes, Shipping, Fiberboard) --unit and intermediate, type CF, class domestic and class weather-resistant, variety single-wall grades 125, 175, 200, 275, V3c, W5c, style RSC.
- VII PPP-B-636 (Boxes, Folding, Paperboard) --unit containers, variety 1, style II, types D, classes a and e
- VIII Unit load arrangements of exterior boxes on the 40" x 48" pallet

FIGURES

	Page
1 Unit Load Arrangement--Box Size No. 2	7
2 Unit Load Arrangement--Box Size No. 3	7
3 Unit Load Arrangement--Box Size No. 4	8
4 Unit Load Arrangement--Box Size No. 5	8
5 Heterogeneous Load Arrangement--Box Sizes Nos. 2, 4, and 5	9
6 Heterogeneous Load Arrangement--Box Sizes Nos. 3, 4, and 5	9

1. SCOPE

1.1 Scope. This standard provides a series of standard wood, plywood and fiberboard boxes to be used as unit, intermediate and exterior containers for packaging of materiel. The modular containers are designed so that the dimensions of the unit pack fit the intermediate container which fits the exterior container for eventual unitization on a 40" by 48" pallet that is compatible for shipment in MILVAN's and SEAVAN's. Container sizes listed herein are compatible to American National Standards MH 10.1 and MH 10.2.

1.2 Applicability. The use of standard size containers listed herein is applicable to all DOD activities engaged in the shipment of general supplies (excluding ammunition to Continental United States (CONUS) and oversea customers). Subject containers are not intended as mandatory for use when separate containers designed for specific categories of commodities have been established.

2. REFERENCED DOCUMENTS

2.1 Issue of documents. The following documents of the issue in effect on date of invitation for bids or request for proposal form a part of the standard to the extent specified herein.

SPECIFICATIONS

Federal

PPP-B-566	Boxes, Folding, Paperboard
PPP-B-585	Boxes, Wood, Wirebound
PPP-B-601	Boxes, Wood, Cleated-Plywood
PPP-B-621	Boxes, Wood, Nailed and Lock Corner
PPP-B-636	Boxes, Shipping, Fiberboard
PPP-B-640	Boxes, Fiberboard, Corrugated, Triple-wall

Military

MIL-STD-147 Palletized Unit Loads, 40" x 48" Pallets

(Copies of specifications, standards, drawings, and publications required by contractors in connection with specific procurement functions should be obtained from the procuring activity or as directed by the contracting officer.)

2.2 Other publications. The following documents form a part of this standard to the extent specified herein. Unless otherwise indicated, the issue in effect on date of invitation for bids or request for proposal shall apply.

MH10.1-1972 Unit-Load Sizes for Dimensioning Transport-Package Sizes

MH10.2-1973 Transport Package Sizes for ANSI MH10.1, Unit-Load Sizes

(Application for copies should be addressed to Sales Department, American National Standards Institute, 1430 Broadway, New York, NY 10018)

MIL-STD-1187
13 February 1976

3. GENERAL REQUIREMENTS

3.1 Dimensions and specification classifications. Dimensions, types, classes, grades and varieties of standard size containers shall be as specified in tables I through VII.

3.1.1 Unit and intermediate container sizes. Unit intermediate container sizes were designed to fit the PPP-B-601 and PPP-B-621 boxes which have the smallest inside dimensions. Dimensions for the PPP-B-601 boxes are based on the use of .500-inch plywood with .875 inch edge cleats and the PPP-B-621 box being constructed of .750-inch lumber. Actual thickness of plywood and wood is determined by weight of contents of each box. Detailed information is included in the applicable box specification.

3.1.2 Applicability. When applicable, exterior containers (tables I through V) may be used as unit containers and unit, intermediate containers (table VI) as exterior containers.

3.1.2 Maximum weight limitations. Maximum weight limitations for standard size containers shall be in accordance with the applicable box specification. Skidding requirements are waived.

3.1.4 Unit load arrangements. Unit load arrangements of containers on the 40" by 48" pallet shall be in accordance with table VIII. Pallets shall be in accordance with requirements of MIL-STD-147.

3.1.4.1 Figures 1 through 4 illustrate unit load arrangements on the 40" by 48" pallet.

3.1.4.2 Figures 5 and 6 illustrate heterogeneous load arrangements on the 40" by 48" pallet.

3.1.5 Palletized unit load weight limitations. Palletized unit load weight limitations shall be in accordance with MIL-STD-147. The height limitations shall not exceed 41 inches, including the pallet base.

3.1.6 Securing of unitized loads to pallets. Unitized loads shall be secured to pallets by the application of shrink film bonding or by strapping as prescribed in MIL-STD-147.

Table 1. PPP-B-601 (Boxes, Wood, Cleated-Plywood)--type-overseas, styles A, B, and I

<u>Box size No.</u>	<u>Inside dimensions (inches)</u>			<u>Inside cube</u>
	<u>Length</u>	<u>Width</u>	<u>Depth</u>	
1	45½ x	37½ x	33½	34.39
2	45½ x	37½ x	15½	16.19
3	37½ x	21½ x	33½	16.45
4	37½ x	21½ x	15½	7.74
5	21½ x	17½ x	15½	3.66

Table II. PPP-B-621 (Boxes, Wood, Nailed and Lock Corner)--class 2, overseas, styles 2 through 4½

<u>Box size No.</u>	<u>Inside dimensions (inches)</u>			<u>Inside cube</u>
	<u>Length</u>	<u>Width</u>	<u>Depth</u>	
1	45 x	38½ x	34½	34.59
2	45 x	38½ x	16½	16.54
3	37 x	22½ x	34½	16.62
4	37 x	22½ x	16½	7.94
5	21 x	18½ x	16½	3.71

MIL-STD-1187
13 February 1976

Table III. PPP-B-585 (Boxes, Wood, Wirebound)--class 3, military overseas

<u>Box size No.</u>	<u>Inside dimensions (inches)</u>			<u>Inside cube</u>
	<u>Length</u>	<u>Width</u>	<u>Depth</u>	
1	45½ x	39¼ x	35¼	36.69
2	45½ x	39¼ x	17¼	17.83
3	39¼ x	23¼ x	35¼	18.62
4	39¼ x	23¼ x	17¼	9.11
5	23¼ x	19¼ x	17¼	4.47

Table IV. PPP-B-640 (Boxes, Fiberboard, Corrugated Triple-wall)-- class 1 domestic and class 2, weather-resistant, style E, RSC

<u>Box size No.</u>	<u>Inside dimensions (inches)</u>			<u>Inside cube</u>
	<u>Length</u>	<u>Width</u>	<u>Depth</u>	
1	47 x	39 x	34	36.07
2	47 x	39 x	16	16.97
3	39 x	23 x	34	17.65
4	39 x	23 x	16	8.31
5	23 x	19 x	16	4.05

Table V. PPP-B-636 (Boxes, Shipping, Fiberboard)--type CF, class domestic and class weather-resistant, variety double-wall, style RSC

<u>Box size No.</u>	<u>Inside dimensions (inches)</u>			<u>Inside cube</u>
	<u>Length</u>	<u>Width</u>	<u>Depth</u>	
1	47½	x 39½	x 35	38.0
2	47½	x 39½	x 17	18.46
3	39½	x 23½	x 35	18.80
4	39½	x 23½	x 17	9.13
5	23½	x 19½	x 17	4.51

Table VI. PPP-B-636 (Boxes, Shipping, Fiberboard)--unit and intermediate, type CF, class domestic and class weather-resistant, variety single-wall grades 125, 175, 200, 275, V3c, W5c, style RSC

<u>Box size No.</u>	<u>Inside dimensions (inches)</u>			<u>No. per exterior container</u>	<u>Exterior container No.</u>
	<u>Length</u>	<u>Width</u>	<u>Depth</u>		
6	22 1/8	x 18 1/4	x 15 7/8	8	1
7	22 1/8	x 18 1/4	x 10 1/4	12	1
8	22 1/8	x 18 1/4	x 7 1/2	16	1
9	22 1/8	x 18 1/8	x 6 7/8	8	2
10	18 1/8	x 10 3/8	x 15 7/8	8	3
11	18 1/8	x 10 3/8	x 10 1/4	12	3
12	18 1/8	x 10 3/8	x 6 7/8	8	4
13	10 1/8	x 8 1/4	x 6 7/8	8	5

MIL-STD-1187
13 February 1976

Table VII. PPP-B-566 (Boxes, Folding, Paperboard) --unit containers, variety 1, style II, type D, classes a and e

<u>Box size No.</u>	<u>Inside dimensions (inches)</u>			<u>No. per Intermediate container</u>	<u>Intermediate container No.</u>
	<u>Length</u>	<u>Width</u>	<u>Depth</u>		
14	10 7/8	x 5 7/8	x 7 5/8	12	6
15	7 3/4	x 5 7/8	x 4 1/8	30	6
16	5 7/8	x 4 1/4	x 1 3/4	75	7
17	4 1/4	x 2 7/8	x 1 3/4	120	8
18	2 7/8	x 1 7/8	x 1 3/4	150	11

Table VIII. Unit load arrangements of exterior boxes on the 40" x 48" pallet

<u>Box size No.</u>	<u>No. boxes per unit load</u>	<u>No. of courses per unit load</u>	<u>No. boxes per course</u>
1	1	1	1
2	2	2	1
3	2	1	2
4	4	2	2
5	8	2	4

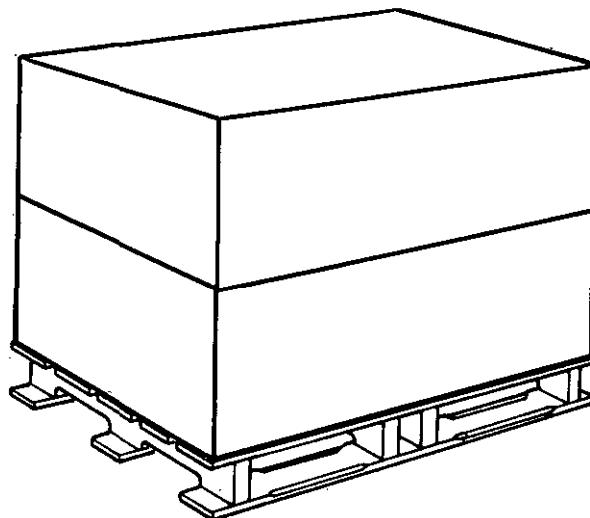

Figure 1. Unit load arrangement--box size No. 2.

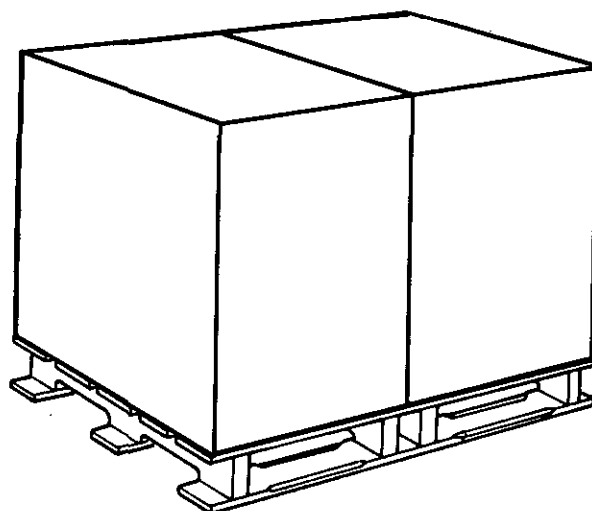

Figure 2. Unit load arrangement--box size No. 3.

MIL-STD-1187
13 February 1976

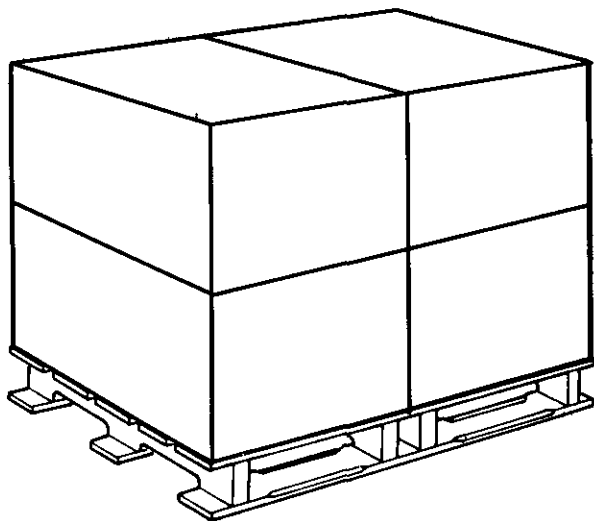

Figure 3. Unit load arrangement--box size No.4.

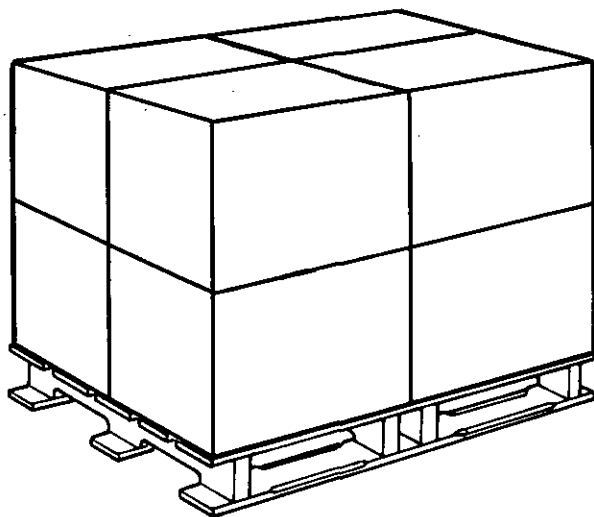

Figure 4. Unit load arrangement--box size No.5.

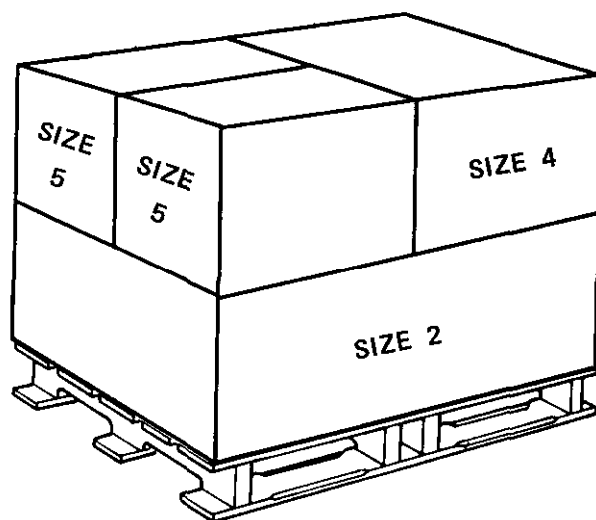

Figure 5. Heterogeneous load arrangement--box sizes Nos. 2, 4 and 5.

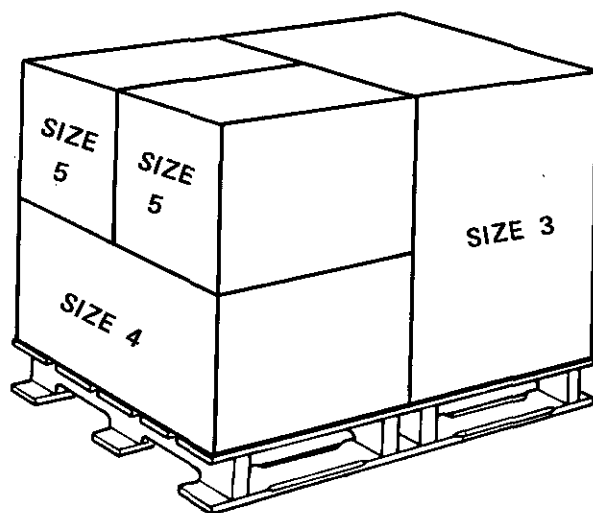

Figure 6. Heterogeneous load arrangement--box sizes Nos. 3, 4 and 5.

MIL-STD-1187
13 February 1976

Custodian:

Army--SM
Air Force--69
DSA--DH
Navy--SA

Preparing Activity:

Army--SM
Project No. PACK 0526

Review Activities:

Army--AT, AV, ME, MI, MU, WE, GL, MT
Air Force--71, 80
DSA--CS, CS
Navy--AS, OS

User Activities:

Air Force--70, 82, 84
Navy--EC, MC, SH, YD
Surgeon General--MD

Civil Agency Interest:

GSA-FMFP